

GV200 User Manual

GPRS/GPS Tracker

TRACGV200UM001

Version:R1.01



Document Title	GV200 User Manual
Version	1.01
Date	2015-10-21
Status	Release
Document Control ID	TRACGV200UM001

General Notes

Queclink offers this information as a service to its customers, to support application and engineering efforts that use the products designed by Queclink. The information provided is based upon requirements specifically provided to Queclink by the customers. Queclink has not undertaken any independent search for additional relevant information, including any information that may be in the customer's possession. Furthermore, system validation of this product designed by Queclink within a larger electronic system remains the responsibility of the customer or the customer's system integrator. All specifications supplied herein are subject to change.

Copyright

This document contains proprietary technical information which is the property of Queclink Wireless Solutions Co., Ltd. The copying of this document and giving it to others and the using or communication of the contents thereof, are forbidden without express authority. Offenders are liable to the payment of damages. All rights reserved in the event of grant of a patent or the registration of a utility model or design. All specification supplied herein are subject to change without notice at any time.

Contents

Contents	2
Table Index	3
Figure Index.....	4
0. Revision History.....	5
1. Introduction	6
1.1. Reference.....	6
1.2. Terms and Abbreviations.....	6
2. Product Overview.....	7
2.1. Appearance	7
2.2. Parts List	8
3. Interface Description.....	9
3.1. SIM Card Interface.....	9
3.2. Antenna Interface.....	10
3.2.1. Install Antennas.....	10
3.2.2. GPS antenna specification.....	10
3.2.3. GSM antenna specification.....	11
3.3. User Interface	12
3.3.1. Interface Definition	12
3.3.2. Power Connection	13
3.3.3. 5V Output	14
3.3.4. Reset Key	14
3.3.5. Ignition Detect.....	14
3.3.6. Ignition Control.....	15
3.3.7. Electrical conditions for digital inputs	16
3.3.8. Digital Input without Interrupt.....	17
3.3.9. Digital Input with Interrupt	18
3.3.10. Analog Input	18
3.3.11. Digital Output	20
3.4. Indicator Light Description	22

Table Index

TABLE 1: REFERENCE	6
TABLE 2: TERMS AND ABBREVIATIONS.....	6
TABLE 3: PART LIST	8
TABLE 4: GPS ANTENNA SPECIFICATION	10
TABLE 5: GSM ANTENNA SPECIFICATION	11
TABLE 6: THE DEFINITION OF 24 PIN CONNECTOR	12
TABLE 7: THE DESCRIPTION OF 24 PIN	13
TABLE 8: ELECTRICAL CONDITIONS OF IGNITION DETECT.....	15
TABLE 9: ELECTRICAL CONDITIONS OF IGNITION CONTROL	15
TABLE 10: ELECTRICAL CONDITIONS OF NEGATIVE TRIGGER DIGITAL INPUTS.....	16
TABLE 11: ELECTRICAL CONDITIONS OF POSITIVE TRIGGER DIGITAL INPUTS	17
TABLE 12: ELECTRICAL CONDITIONS OF DIGITAL OUTPUTS	20
TABLE 13: DESCRIPTION OF LEDS	23

Figure Index

FIGURE 1: APPEARANCE OF GV200	7
FIGURE 2: SIM CARD INTERFACE	9
FIGURE 3: SIM CARD INSTALLATION	9
FIGURE 4: THE ANTENNAS OF GV200	10
FIGURE 5: THE SEQUENCE OF 24 PIN CONNECTOR	12
FIGURE 6: EXAMPLE OF POWER CONNECTION	14
FIGURE 7: THE KEY OF RESET	14
FIGURE 8: IGNITION DETECTION	15
FIGURE 9: EXAMPLE CONNECTION OF IGNITION CONTROL	16
FIGURE 10: EXAMPLE CONNECTION FOR NEGATIVE TRIGGER DIGITAL INPUTS	17
FIGURE 11: EXAMPLE CONNECTION FOR POSITIVE TRIGGER DIGITAL INPUTS	17
FIGURE 12: EXAMPLE CONNECTION OF PANIC BUTTON	18
FIGURE 13: AIN1 CONNECT TO NTC RESISTOR	19
FIGURE 14: AIN2/3 CONNECT TO CAPACITANCE-TYPE SENSOR	19
FIGURE 15: THE EXAMPLE CONNECTION TO DRIVE A LED	20
FIGURE 16: THE EXAMPLE CONNECTION TO DRIVE A RELAY	21
FIGURE 17: LEDS ON GV200	22

0. Revision History

Revision	Date	Author	Description of change
1.00	2015-10-14	Richard Deng	Initial
1.01	2015-10-21	Bingo Huang	<ol style="list-style-type: none">1. Page 10 , The GPS Power Supply Voltage is 3V ,not 3.3V2. Add Diode Description of the Relay driver, Page 17, figure 9 和 Page 22 figure 16.

1. Introduction

The GV200 is a powerful GPS Locator designed for vehicle tracking or assets tracking. With superior receiving sensitivity, fast TTFF (Time to First Fix) and Dual-Band GSM frequencies 850/1900, its location can be monitored in real time or periodically tracked by a backend server or other specified terminals. The GV200 has multiple input/output interfaces which can be used for monitoring or controlling external devices. Based on the integrated @Track protocol, the GV200 can communicate with a backend server through the GPRS network to transfer reports of Emergency, Geo-fence boundary crossings, Lower Battery or scheduled GPS position along with many other useful functions. Users can also use GV200 to monitor the status of a vehicle and control the vehicle with its external relay output. System Integrators can easily setup their tracking systems based on the full-featured @Track protocol.

1.1 Reference

Table 1: Reference

SN	Document name	Remark
[1]	GV200 @Track Air Interface Protocol	The air protocol interface between GV200 and backend server.

1.2 Terms and Abbreviations

Table 2: Terms and abbreviations

Abbreviation	Description
AGND	Analog Ground
AIN	Analog Input
DIN	Digital Input
DOUT	Digital Output
GND	Ground
MIC	Microphone
RXD	Receive Data
TXD	Transmit Data
SPKN	Speaker Negative
SPKP	Speaker Positive

2. Product Overview

2.1 Appearance



Figure 1: Appearance of GV200

2.2 Parts List

Table 3: Part List

Name	Picture
GV200 Locater	
User Cable	
GPS Antenna	
GSM Antenna	
12V DC power supply (Optional)	
USB-232 data cable (Optional)	
Uart Cable (Optional)	
Extend Cable (Optional)	

3. Interface Description

3.1 SIM Card Interface

To install the SIM card

Step 1: Press the yellow button on the right side of SIM card slot to eject the SIM card holder.

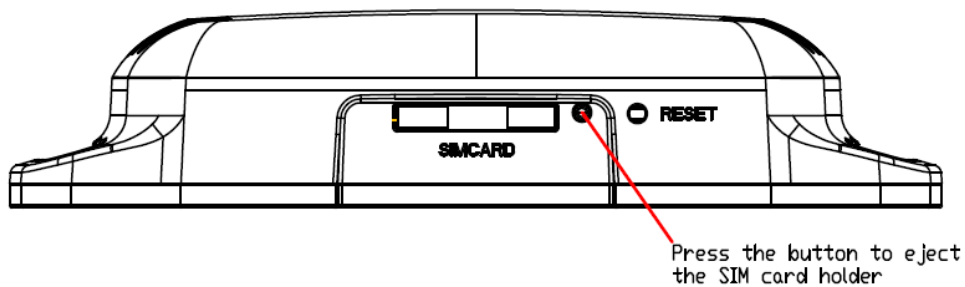

Figure 2: SIM Card Interface

Step 2: Put the SIM card on the SIM card holder.

Step 3: Install the SIM card holder to SIM card slot. Please pay attention to the direction.

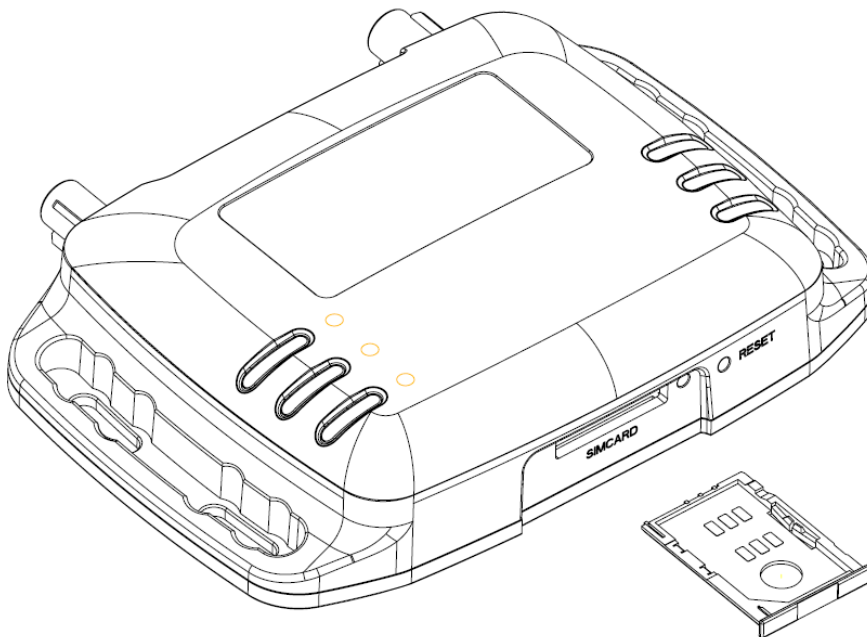

Figure 3: SIM Card Installation

3.2 Antenna Interface

3.2.1 Install Antennas

There are two Fakra antenna connectors on GV200, the blue one for GPS and the purple one for GSM. Please find the GPS antenna and GSM antenna in package box. Install them to the correct Fakra connector as following.

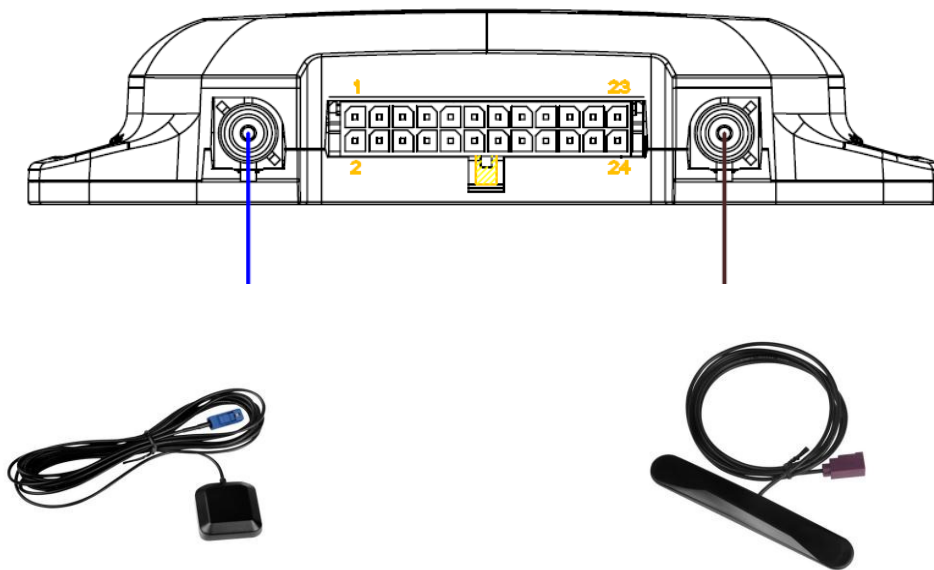

Figure 4: The Antennas of GV200

3.2.2 GPS antenna specification

Table 4: GPS antenna specification

GPS antenna:	Frequency: 1575.42MHz
Bandwidth:	>5MHz
Beamwidth:	>120 deg
Supply voltage:	3V
Polarization:	RHCP
Gain:	Internal antenna: 0dBi External antenna: 15dB
Impedance:	50Ω
VSWR:	< 2
Noise figure:	< 3

3.2.3 GSM antenna specification

Table 5: GSM antenna specification

GSM antenna specification	
Frequency and bandwidth	GSM850: 824MHz to 894MHz PCS1900: 1850MHz to 1990MHz
Direction:	Omnidirection
Gain:	Passive: >0dBi
Impedance:	50Ω
VSWR:	<4
Efficient:	GSM850: >40% PCS1900: >30%

3.3 User Interface

3.3.1 Interface Definition

There is a 24 PIN connector on GV200. It contains the interface of power, I/O, RS232, microphone, speaker, etc. The sequence and definition of the 24 PIN connector are showed in following figure:

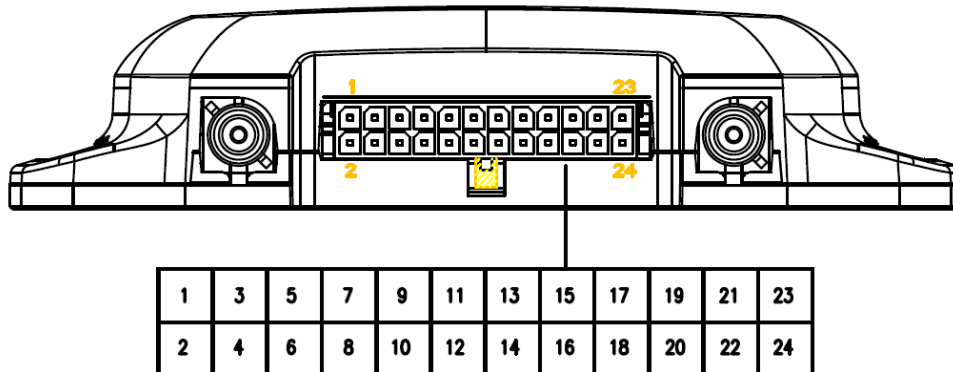

Figure 5: The sequence of 24 PIN connector

Table 6: The definition of 24 PIN connector

1	3	5	7	9	11	13	15	17	19	21	23
AGND	AIN1	AIN2	AIN3	RXD2	TXD2	DTR	RXD	TXD	VOUT	DOUT1	GND
2	4	6	8	10	12	14	16	18	20	22	24
MIC	SPKP	SPKN	DIN4	DIN3	DIN2	DIN1	DOUT4	GND	DOUT3	DOUT2	VIN

Table 7: The description of 24 PIN

Index	Color of User cable	Description	Comment
1	Black	Analog Ground	For microphone and analog inputs
2	Blue	Microphone Input	MIC+
3	Green	Analog Input 1 (Input range: 0 ~ 2.7V)	For resistance-type sensors
4	Blue	Speaker Output	Differential, Positive
5	Green	Analog Input 2	For capacitance-type sensors
6	Blue	Speaker Output	Differential, Negative
7	Green	Analog Input 3	For capacitance-type or resistance-type sensors
8	White	Digital Input 4	Negative Trigger
9	Orange	Receive Data (UART2, RS232)	Connect to TXD of external device
10	White	Digital Input 3	Positive Trigger, With interrupt
11	Orange/Gray	Transmit Data (UART2, RS232)	Connect to RXD of external device
12	White	Digital Input 2	Negative Trigger, with interrupt. Recommended for panic button
13	Orange/Brown	DTR	Data Terminal Ready. For waking up UART1 & UART2
14	White	Digital Input 1 (ACC Detect)	Positive Trigger, fixed for ignition detect
15	Orange	Receive Data (UART1, RS232)	Connect to TXD of external device
16	Yellow	Digital Output 4	Negative Trigger
17	Orange/Gray	Transmit Data (UART1, RS232)	Connect to RXD of external device
18	Black	Ground	For 5V output and UART
19	Purple	5V Output	VOUT
20	Yellow	Digital Output 3	Negative Trigger
21	Yellow	Digital Output 1	Negative Trigger
22	Yellow	Digital Output 2	Negative Trigger
23	Black	Ground	Power Ground
24	Red	Power	Power (VIN)

3.3.2 Power Connection

PIN 24 is named as VIN which input voltage range is 12V or 24V DC and can be connected to vehicle's battery directly (12V or 24V DC).

Please install the power like following.

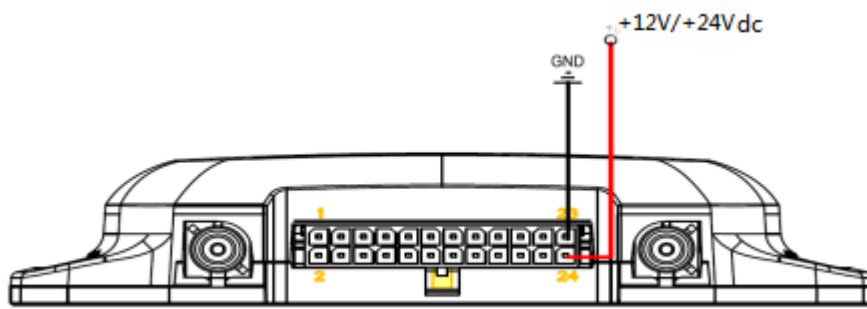

Figure 6: Example of power connection

3.3.3 5V Output

PIN 19 is named as VOUT which can drive a controlled 5V output for user. Please note that if user wants to drive a 5V output, GV200 must be supplied by external power. In default, 5V output is disabled, user can use AT commend to enabled 5V output. The max drive current of VOUT is 0.25A.

3.3.4 Reset Key

There is a reset key on the right side of SIM Card interface. When the key is pressed, the device will reboot. Please note that reboot do not change any firmware parameter.

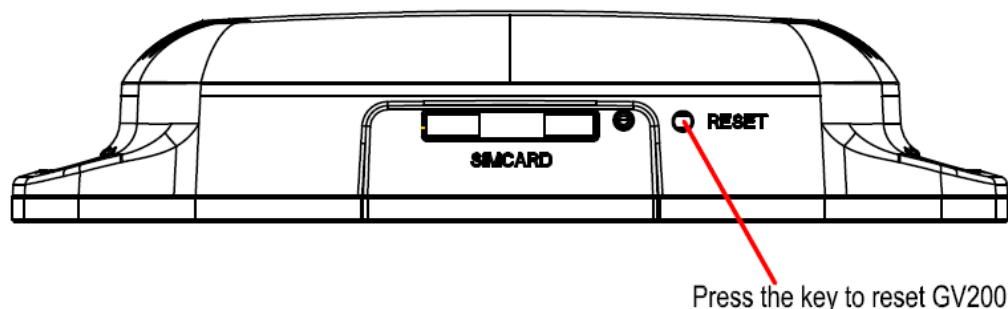

Figure 7: The key of reset

3.3.5 Ignition Detect

The PIN 14 is DIN1 (Positive trigger). Its electrical conditions are:

Table 8: Electrical conditions of ignition detect

Logical State	Electrical State
Active	12V/24V
Inactive	0V to 3V or Open

It is strongly recommended to connect this pin to ignition key to support the power saving function when the vehicle is off.

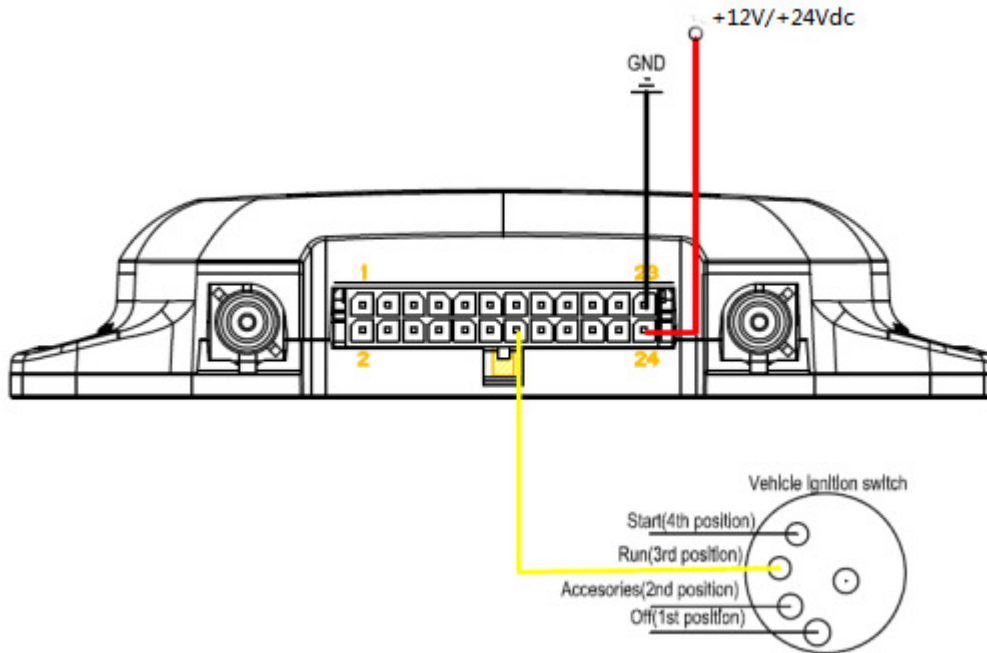
**Figure 8: Ignition detection**

Another easy way is to connect PIN14 to a power output in the fuse box of the vehicle which is only enabled after the vehicle is ignition on. For example: the power output for radio FM.

3.3.6 Ignition Control

DOUT1/2/3/4 can be used to control ignition key. They are Open-Drain type with no internal pull-up resistor which also be used to control a relay. It means that the user has to connect a pull-up resistor or a relay coil between the DOUT1/2/3/4 pin and any positive voltage to generate a correct output. The DOUT1/2/3/4 pin can drive a continuous current of 0.2A.

The electrical conditions of it are:

Table 9: Electrical conditions of ignition control

Logical State	Electrical State
Enable	<1.5V, drive current is 0.2A
Disable	Open or the pull-up voltage

User can use this pin to control a relay output. An example to control the ignition key is showed in following figure. Please refer to chapter 3.3.11 for the detail information on how to drive a relay with digital output.

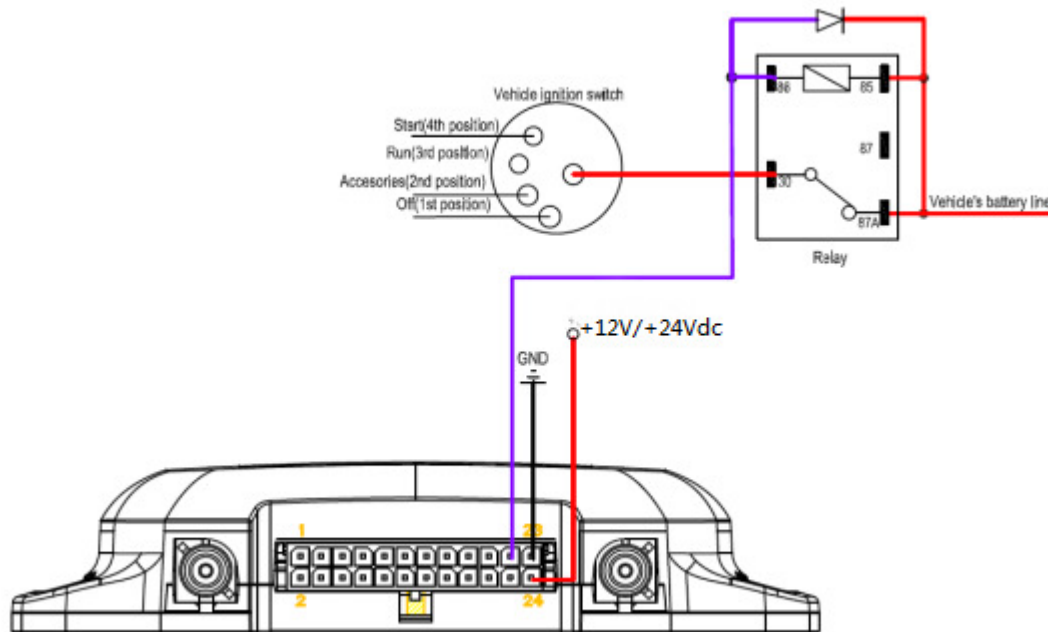

Figure 9: Example connection of ignition control

3.3.7 Electrical conditions for digital inputs

For negative trigger inputs the electrical conditions are:

Table 10: Electrical conditions of negative trigger digital inputs

Logical State	Electrical State
Active	0V to 0.8V
Inactive	1.7V to 32V or Open

The example connection is showed as follow:

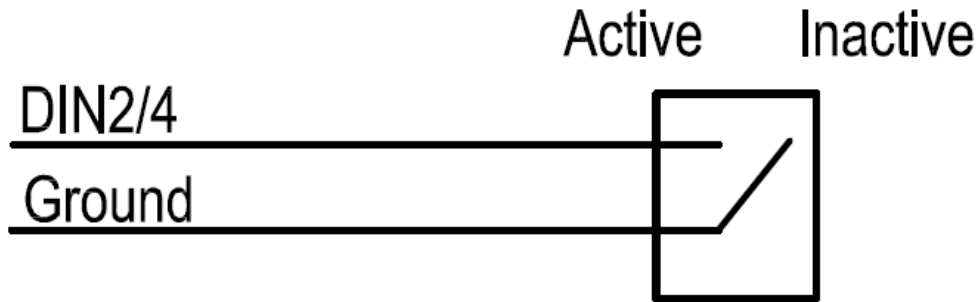

Figure 10: Example connection for negative Trigger digital inputs

For positive trigger inputs the electrical conditions are:

Table 11: Electrical conditions of positive trigger digital inputs

Logical State	Electrical State
Active	5.0V to 32V
Inactive	0V to 3V or Open

The example connection is showed as follow:

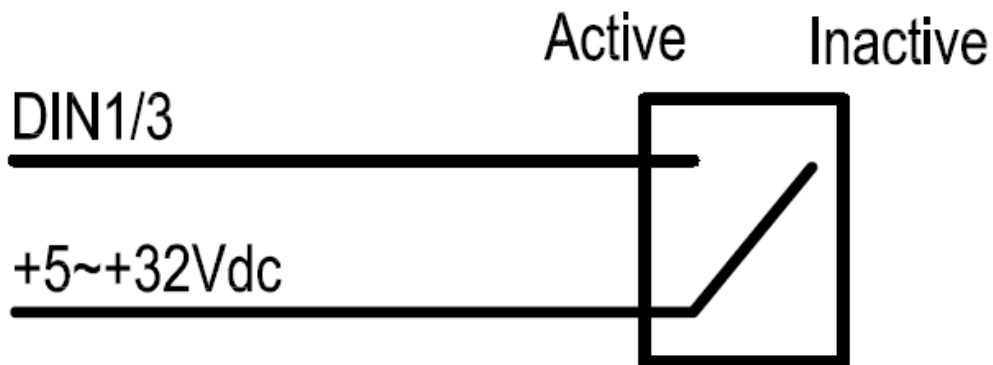

Figure 11: Example connection for positive trigger digital inputs

3.3.8 Digital Input without Interrupt

The DIN1 and DIN4 are digital inputs which do not have interrupt. DIN1 is positive trigger and DIN4 is negative trigger. The sample rate for this digital input is 2 to 24 seconds. Please note the high sample rate will also result in high power consumption.

3.3.9 Digital Input with Interrupt

DIN2 and DIN3 are digital inputs which have interrupt. DIN2 is negative trigger and DIN3 is positive trigger.

The example connections are same as showed in chapter 3.3.7.

DIN2 is also recommended to support panic button function and the connection is showed as follow.

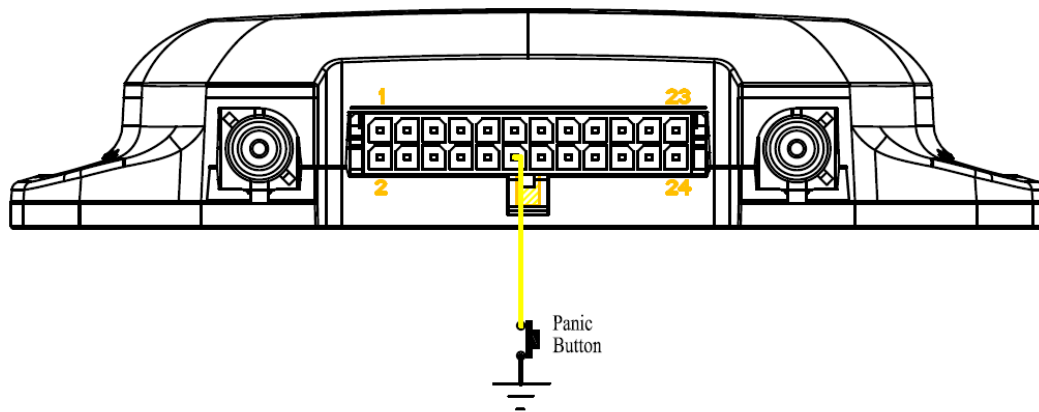

Figure 12: Example connection of panic button

3.3.10 Analog Input

The PIN 3/5/7 are used for analog to digital converter. GV200 can support different type sensors such as resistance-type and capacitance-type due to the differences between the three analog inputs. Please note it is an average value based on the sample rate from 2 to 24 seconds, which means the burst on voltage input may not be detected.

3.3.10.1 Resistance-type Sensor

AIN1 (PIN 3) is designed to support some resistance-type sensors and there is an internal pull-up resistor (100K Ohm) on its channel. Due to the internal pull-up resistor, user can connect resistance-type sensors directly between analog inputs and AGND. The follow figure is the example connection of AIN1 with NTC resistor. The recommended value of NTC resistor is 100K@25°C.

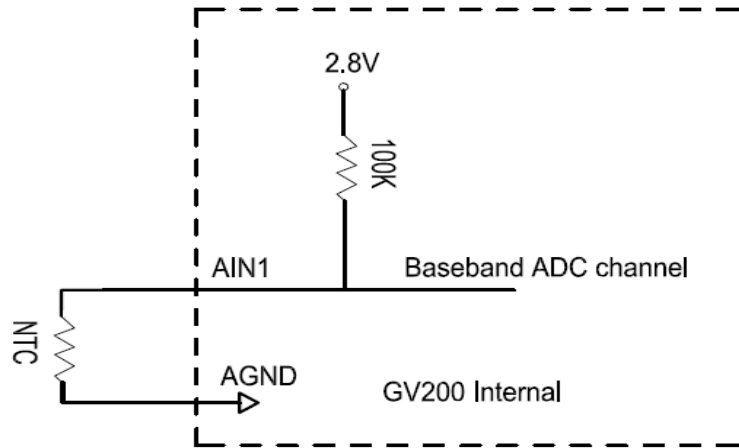

Figure 13: AIN1 connect to NTC resistor

3.3.10.2 Capacitance-type Sensor

AIN2 (PIN 5) and AIN3 (PIN 7) are designed to support capacitance-type sensors. In default GV200 only support capacitance-type sensors which voltage range is 0 ~ 2.7V. If user wants to use the capacitance-type sensors which voltage range is out of 0 ~ 2.7V, a level transfer board must be used between capacitance-type sensors and GV200. The follow figure is the example connection of AIN2/3 with capacitance-type sensors.

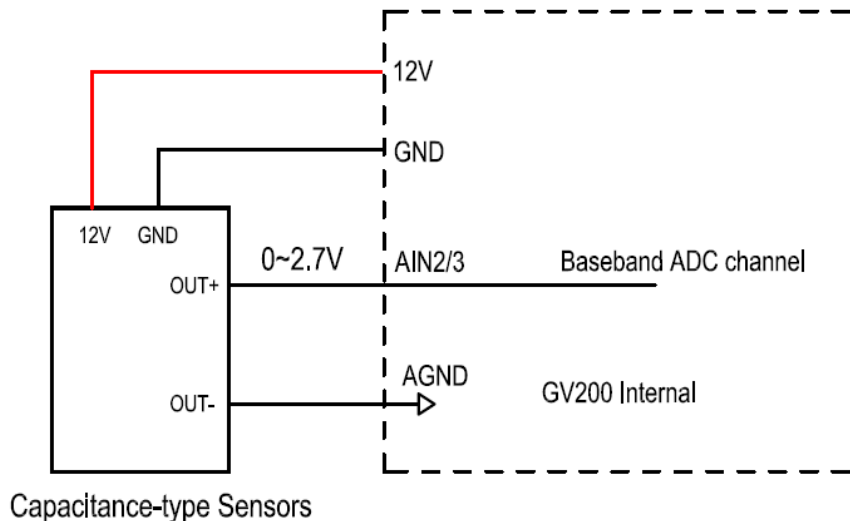

Figure 14: AIN2/3 connect to capacitance-type sensor

User also can connect a power source directly to AIN2/3, the voltage limitation is same as capacitance-type sensor.

3.3.11 Digital Output

The outputs are Open-Drain type with no internal pull-up resistor which also be used to control a relay. It means that the user has to connect a pull-up resistor or a relay coil between the output pin and any positive voltage to generate a correct output. Each output can drive a continuous current of 0.2A.

The electrical conditions are:

Table 12: Electrical conditions of digital outputs

Logical State	Electrical State
Enable	<1.5V, drive current is 0.2A
Disable	Open or the pull-up voltage

Digital outputs are used for cutting/restoring GND. The example connections are:

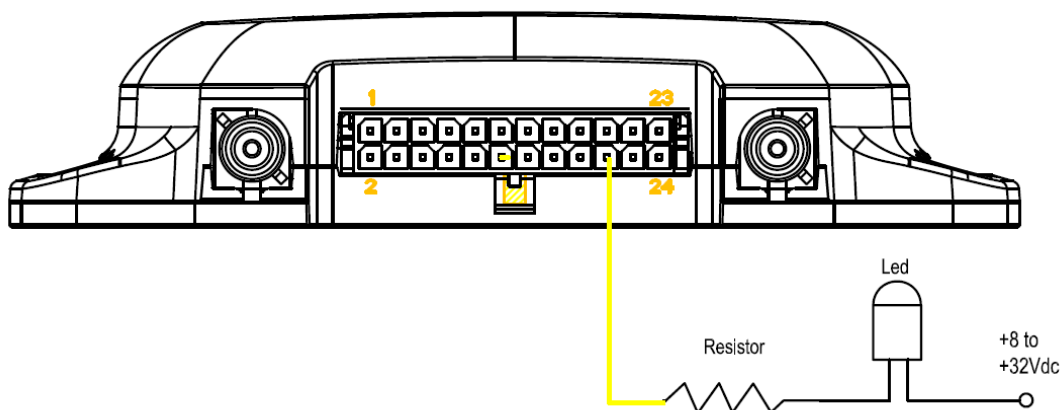

Figure 15: The example connection to drive a LED

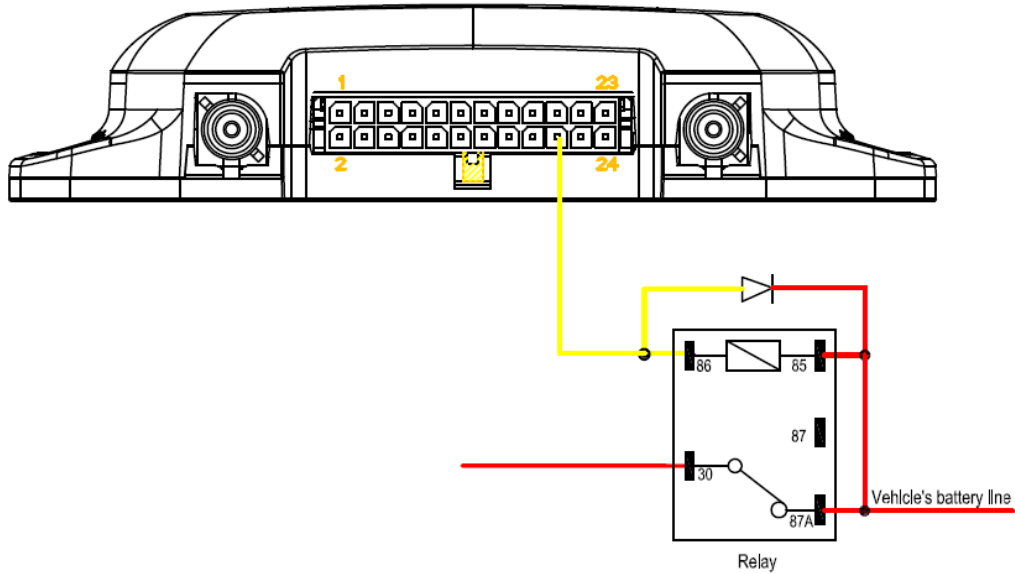

Figure 16: The example connection to drive a relay

Note: All outputs are internally pulled up to PWR pin by a diode. So no external flyback diode is needed when the output is connected to an inductive load.

If the digital output is used to drive a relay, a catch diode is showed across the relay coil, this is necessary to prevent damage to the digital output when the relay is turned off. Many modern relays come with this diode pre-installed internal to the relay itself. If the relay has this diode, insure the proper relay polarity connected is used. If this diode is not internal, it should be added externally. A common diode such as a 1N4004 will work in most circumstances.

3.4 Indicator Light Description

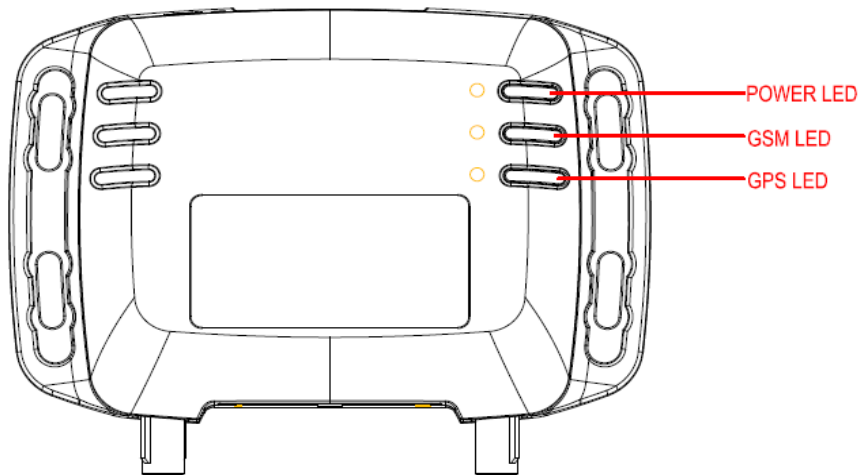

Figure 17: LEDs on GV200

There are three LEDs in GV200, the description as follow.

Table 13: Description of LEDs

Light	Case	State
GPS LED	If LED switch is set to off by AT+GTCFG, GPS LED will be off all the time after it has worked for 30 minutes maximum from GV200 was powered on. In this case, cases for GPS LED listed below will be ignored.	Always Off
	GPS LED will be off if GPS chip is closed.	Off
	Checksum of NEMA packet from GPS chip is invalid.	Slow flashing
	There is no data output from GPS chip when it is working.	
	GPS chip is trying to get valid GPS info.	Fast flashing
	GPS chip has been getting valid GPS info.	On
PWR LED	If LED switch is set to off by AT+GTCFG, PWR LED will be off all the time after it has worked for 30 minutes maximum from GV200 was powered on. In this case, cases for PWR LED listed below will be ignored.	Always Off
	Backup battery is enabled and its voltage is not low if external power supply is cut.	Off
	Backup battery is enabled and its voltage is low if external power supply is cut.	Slow flashing
	Backup battery is enabled and it is in charging by external power supply.	Fast flashing
	Backup battery is enabled and it is fully charged by external power supply.	On
	Backup battery is disabled and external power supply is connected.	
GSM LED	GV200 is in searching GSM network state.	Fast flashing
	GV200 has been registered to GSM network.	Slow flashing
	SIM card inserted to GV200 need pin code to unlock.	On

FCC Warning:

Any Changes or modifications not expressly approved by the party responsible for compliance could void the user's authority to operate the equipment.

This device complies with part 15 of the FCC Rules. Operation is subject to the following two conditions: (1) This device may not cause harmful interference, and (2) this device must accept any interference received, including interference that may cause undesired operation.

FCC Radiation Exposure Statement:

This equipment complies with FCC radiation exposure limits set forth for an uncontrolled environment .This equipment should be installed and operated with minimum distance 20cm between the radiator& your body.

This transmitter must not be co-located or operating in conjunction with any other antenna or transmitter.