



# GSM/GPRS/GPS Tracker **GV300N**

## User Manual

Application Notes: TRACGV300NUM001

Revision: 1.00



<http://www.queclink.com>

[sales@queclink.com](mailto:sales@queclink.com)

<b>Document Title</b>	GV300N User Manual
<b>Version</b>	1.00
<b>Date</b>	2014-11-17
<b>Status</b>	Release
<b>Document Control ID</b>	TRACGV300NUM001

### **General Notes**

Queclink offers this information as a service to its customers, to support application and engineering efforts that use the products designed by Queclink. The information provided is based upon requirements specifically provided to Queclink by the customers. Queclink has not undertaken any independent search for additional relevant information, including any information that may be in the customer's possession. Furthermore, system validation of this product designed by Queclink within a larger electronic system remains the responsibility of the customer or the customer's system integrator. All specifications supplied herein are subject to change.

### **Copyright**

This document contains proprietary technical information which is the property of Queclink. Copying of this document, and giving it to others and the using or communication of the contents thereof, are forbidden without express authority. Offenders are liable to the payment of damages. All rights reserved in the event of grant of a patent or the registration of a utility model or design. All specifications supplied herein are subject to change without notice at any time.

*Copyright © Queclink Wireless Solutions Co., Ltd. 2014*

## Contents

Contents .....	3
0. Revision History .....	6
1. Introduction .....	7
1.1 Reference .....	8
1.2 Terms and Abbreviations .....	8
2. Product Overview .....	9
2.1 Check Parts List .....	9
2.2 Parts List .....	10
2.3 Interface Definition .....	11
2.4 GV300N User Cable Color .....	12
3. Get Started .....	13
3.1 Open the Case .....	13
3.2 Close the Case .....	13
3.3 Install a SIM Card .....	14
3.4 Install the Internal Backup Battery .....	14
3.5 Switch on the Backup Battery .....	15
3.6 Install the External GPS Antenna (Optional) .....	15
3.6.1 GPS Antenna Specification .....	16
3.7 Power Connection .....	16
3.8 Ignition Detection .....	17
3.9 Digital Inputs .....	17
3.10 Analog Inputs .....	18
3.11 Digital Outputs .....	19
3.12 Device Status LED .....	20
3.13 Serial Port/UART Interface .....	21
3.13.1 Connect with Garmin GPS Set .....	22
3.13.2 Connect with CAN100 device .....	23

## Table Index

TABLE 1.	GV300N PROTOCOL REFERENCE.....	8
TABLE 2.	TERMS AND ABBREVIATIONS.....	8
TABLE 3.	PARTS LIST.....	10
TABLE 4.	DESCRIPTION OF 16 PIN CONNECTIONS.....	11
TABLE 5.	GV300N USER CABLE COLOR DEFINITION .....	12
TABLE 6.	GPS ANTENNA SPECIFICATION.....	16
TABLE 7.	ELECTRICAL CHARACTERISTICS OF IGNITION DETECTION .....	17
TABLE 8.	ELECTRICAL CHARACTERISTICS OF THE DIGITAL INPUTS .....	17
TABLE 9.	ELECTRICAL CHARACTERISTICS OF DIGITAL OUTPUTS .....	19
TABLE 10.	DEFINITION OF DEVICE STATUS AND LED .....	21
TABLE 11.	EXTERNAL INTERFACE OF CAN100 DEVICE.....	23
TABLE 12.	CAN100 DEVICE CONNECTS WITH GV300N .....	23

## Figure Index

FIGURE 1.	APPEARANCE OF GV300N .....	9
FIGURE 2.	THE 16 PIN CONNECTOR ON THE GV300N.....	11
FIGURE 3.	OPEN THE CASE.....	13
FIGURE 4.	CLOSE THE CASE.....	13
FIGURE 5.	SIM CARD INSTALLATION.....	14
FIGURE 6.	BACKUP BATTERY INSTALLATION .....	14
FIGURE 7.	SWITCH AND ON/OFF POSITION .....	15
FIGURE 8.	GPS ANTENNA OF GV300N .....	15
FIGURE 9.	TYPICAL POWER CONNECTION.....	16
FIGURE 10.	TYPICAL IGNITION DETECTION .....	17
FIGURE 11.	TYPICAL DIGITAL INPUT CONNECTION .....	18
FIGURE 12.	TYPICAL ANALOG INPUT CONNECTION .....	18
FIGURE 13.	DIGITAL OUTPUT INTERNAL DRIVE CIRCUIT .....	19
FIGURE 14.	TYPICAL CONNECTION WITH RELAY .....	19
FIGURE 15.	TYPICAL CONNECTION WITH LED .....	20
FIGURE 16.	GV300N LED ON THE CASE .....	20
FIGURE 17.	TYPICAL CONNECTION WITH RS232 PORT .....	22
FIGURE 18.	GV300 CONNECTION WITH GARMIN GPS SET .....	22
FIGURE 19.	THE EXTERNAL INTERFACE OF CAN100 DEVICE.....	23



## 1. Introduction

The GV300N is a powerful GPS locator designed for vehicle or asset tracking. It has superior receiver sensitivity, fast TTFF (Time to First Fix) and supports quad band GSM frequencies GSM850/GSM900/DCS/PCS. Its location can be monitored in real time or periodically tracked by a backend server or other specified terminals. The GV300N has multiple input/output interfaces that can be used for monitoring or controlling external devices. Based on the integrated @Track protocol, the GV300N can communicate with a backend server through the GPRS/GSM network to transfer reports of emergency, geo-fence boundary crossings, low backup battery and scheduled GPS position as well as many other useful functions. Users can also use GV300N to monitor the status of a vehicle and control the vehicle by its external relay output. System integrators can easily set up their tracking systems based on the full-featured @Track protocol.

**WARNING:** This device complies with part 15 of the FCC Rules. Operation is subject to the following two conditions:

- (1) This device may not cause harmful interference, and
- (2) This device must accept any interference received, including interference that may cause undesired operation.

Changes or modifications not expressly approved by the party responsible for compliance could void the user's authority to operate the equipment.

**NOTE:**

This equipment has been tested and found to comply with the limits for a Class B digital device, pursuant to part 15 of the FCC Rules. These limits are designed to provide reasonable protection against harmful interference in a residential installation. This equipment generates, uses and can radiate radio frequency energy and, if not installed and used in accordance with the instructions, may cause harmful interference to radio communications. However, there is no guarantee that interference will not occur in a particular installation.

If this equipment does cause harmful interference to radio or television reception, which can be determined by turning the equipment off and on, the user is encouraged to try to correct the interference by one or more of the following measures:

- Reorient or relocate the receiving antenna.
- Increase the separation between the equipment and receiver.
- Connect the equipment into an outlet on a circuit different from that to which the receiver is connected.
- Consult the dealer or an experienced radio/TV technician for help.

**FCC RF Exposure Statement:**

**For the product, under normal use condition is at least 20cm away from the body of the user, the user must keeping at least 20cm distance to the product.**

## 1.1 Reference

**Table 1. GV300N Protocol Reference**

SN	Document name	Remark
[1]	GV300N @Track Air Interface Protocol	The air protocol interface between GV300N and backend server.

## 1.2 Terms and Abbreviations

**Table 2. Terms and Abbreviations**

Abbreviation	Description
AGND	Analog Ground
AIN	Analog Input
DIN	Digital Input
DOUT	Digital Output
GND	Ground
MIC	Microphone
RXD	Receive Data
TXD	Transmit Data
SPKN	Speaker Negative
SPKP	Speaker Positive



## 2. Product Overview

### 2.1. Check Parts List



Before starting, check whether all the following items have been included with your GV300N. If anything is missing, please contact your supplier.



Figure 1. Appearance of GV300N

## 2.2. Parts List

**Table 3. Parts List**

Name	Picture
GV300N Locator	80*49*26 mm
User Cable	
GPS Antenna (Optional)	
DATA_CABLE_M (Optional)	

## 2.3. Interface Definition

The GV300N has a 16 PIN interface connector which contains the connections for power, I/O, RS232, microphone, speaker, etc. The sequence and definition of the 16PIN connector are shown in the following figure:



Figure 2. The 16 PIN Connector on the GV300N

Table 4. Description of 16 PIN Connections

Index	Description	Comment
1	MICP	Single end, 2-2.2k microphone, internal bias
2	AGND	Analog ground
3	IGN	Ignition input, positive trigger
4	RXD	UART RXD, RS232
5	TXD	UART TXD, RS232
6	GND	Power and digital ground
7	OUT3	Open drain, 150 mA max
8	OUT2	Open drain, 150 mA max
9	EARP	Differential output, 32 ohm 1/4w speaker
10	EARN	
11	PWR	External DC power input, 8-32V
12	IN2	Digital input, negative trigger
13	IN1	Digital input, negative trigger
14	OUT1	Open drain, 150 mA max ,with latch circuit
15	AD1/IN3	Multifunction input, analog or digital input 0-16V
16	AD2	Analog input 0.3-16V

## 2.4. GV300N User Cable Color

**Table 5. GV300N User Cable Color Definition**

Definition	Color	PIN No	Cable	PIN No	Color	Definition
OUT2	Yellow	8		16	Brown/White	AD2
OUT3	Brown	7		15	Green	AD1/IN3
GND	Black	6		14	Blue	OUT1
TXD	White/Black	5		13	Orange	IN1
RXD	Pink	4		12	Orange/Black	IN2
IGN	White	3		11	Red	PWR
AGND	Gray/Black	2		10	Purple/White	EARN
MICP	Gray	1		9	Purple	EARP

## 3. Get Started

### 3.1. Open the Case

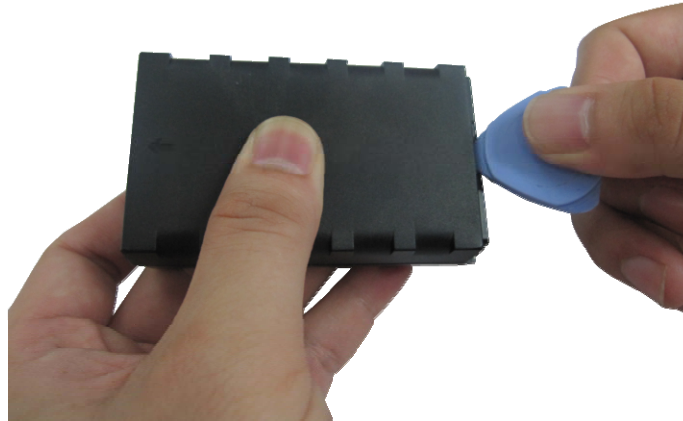

**Figure 3. Open the Case**

Insert the triangular-pry-opener into the gap of the case as shown above, and push the opener up until the case is unsnapped.

### 3.2. Close the Case



**Figure 4. Close the Case**

Place the cover on the bottom in the position as shown in the figure above. Slide the cover against the direction of the arrow until it snaps.

### 3.3. Install a SIM Card

Open the case and ensure the unit is not powered (unplug the 16Pin cable and switch the internal battery to the OFF position). Slide the holder right to open the SIM card holder. Insert the SIM card into the holder as shown below with the gold-colored contact area facing down. Take care to align the cut mark. Close the SIM card holder. Close the case.

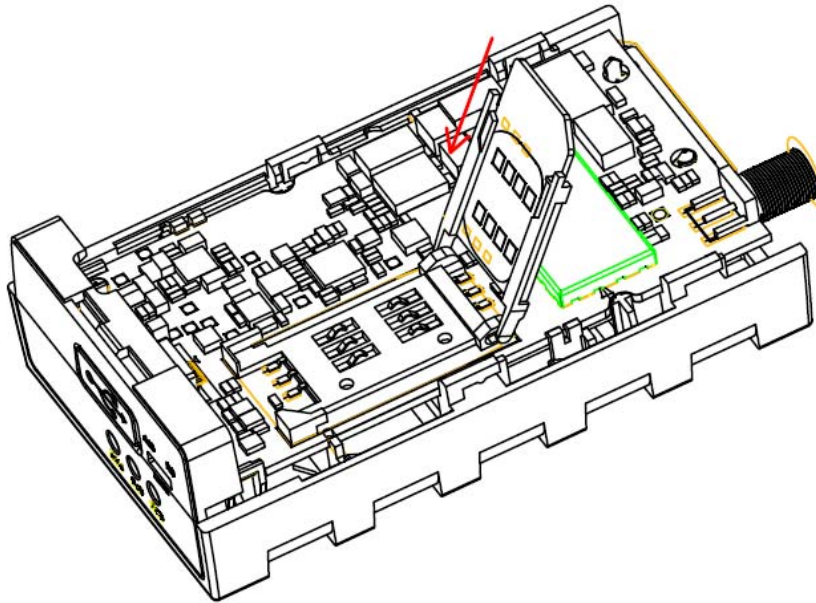

Figure 5. SIM Card Installation

### 3.4. Install the Internal Backup Battery

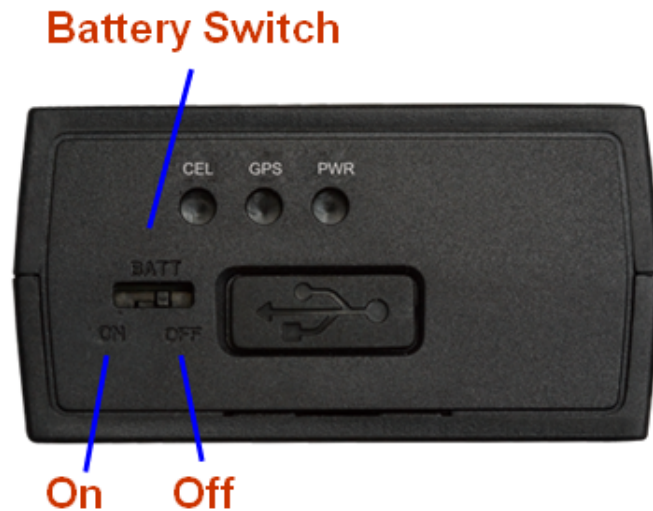

Figure 6. Backup Battery Installation

GV300N has an internal backup Li-ion battery.

### 3.5. Switch on the Backup Battery

To use the GV300N backup battery, the switch must be in the ON position. The switch on the case and the ON/OFF position are shown below.



**Figure 7. Switch and ON/OFF Position**

**Note:**

1. The switch must be in the “OFF” position when the GV300N is shipped on an aircraft.
2. When the switch is in the “OFF” position, the battery cannot be charged or discharged.

### 3.6. Install the External GPS Antenna (Optional)

There is a SMA GPS antenna connector on GV300N. The GV300N will automatically detect and use an external antenna when connected.



**Figure 8. GPS Antenna of GV300N**

### 3.6.1. GPS Antenna Specification

**Table 6. GPS Antenna Specification**

GPS antenna	Frequency: 1575.42 MHz
Bandwidth	>5 MHz
Beam width	>120 deg
Supply voltage	2.7V-3.3V
Polarization	RHCP
Gain	Passive: 0 dBi min Active: 15 dB
Impedance	50Ω
VSWR	<2
Noise figure	<3

### 3.7. Power Connection

PWR (PIN12)/GND (PIN6) is the power input pin. The input voltage range for this device is from 8V to 32V. The device is designed to be installed in vehicles that operate on 12V or 24V systems without the need for external transformers.

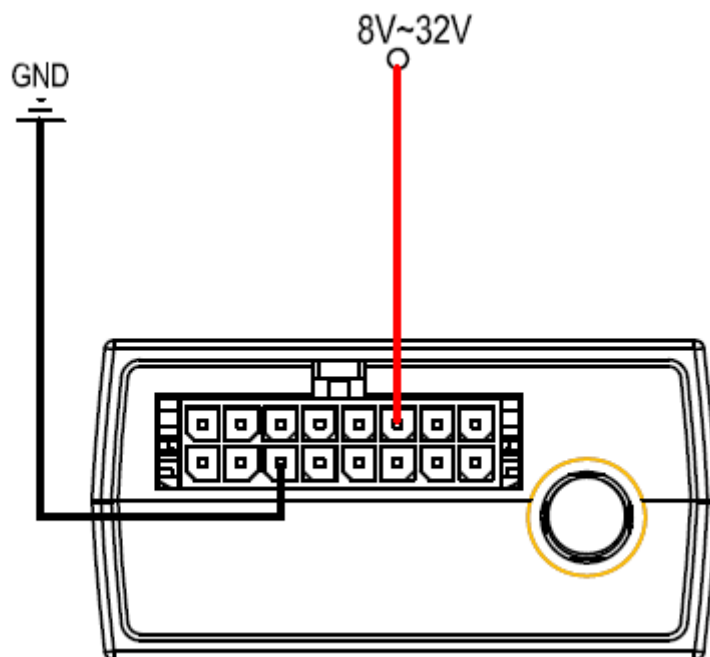

**Figure 9. Typical Power Connection**



### 3.8. Ignition Detection

**Table 7. Electrical Characteristics of Ignition Detection**

Logical status	Electrical characteristics
Active	5.0V to 32V
Inactive	0V to 3V or open

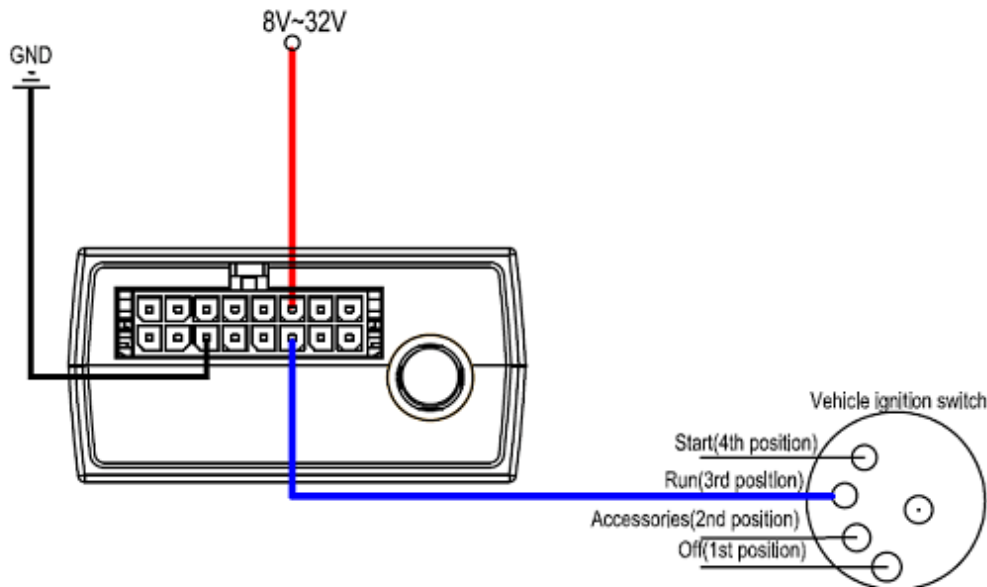

**Figure 10. Typical Ignition Detection**

IGN (Pin3) is used for ignition detection. It is strongly recommended to connect this pin to ignition key “RUN” position as shown above.

An alternative to connecting to the ignition switch is to find a non-permanent power source that is only available when the vehicle is running, for example, the power source for the FM radio.

IGN signal can be configured to start transmitting information to the backend server when ignition is on, and enter the power saving mode when ignition is off.

### 3.9. Digital Inputs

There are three general purpose digital inputs on GV300N. They are all negative triggers.

**Table 8. Electrical Characteristics of the Digital Inputs**

Logical status	Electrical characteristics
Active	0V to 0.8V
Inactive	Open

The following diagram shows the recommended connection of a digital input.

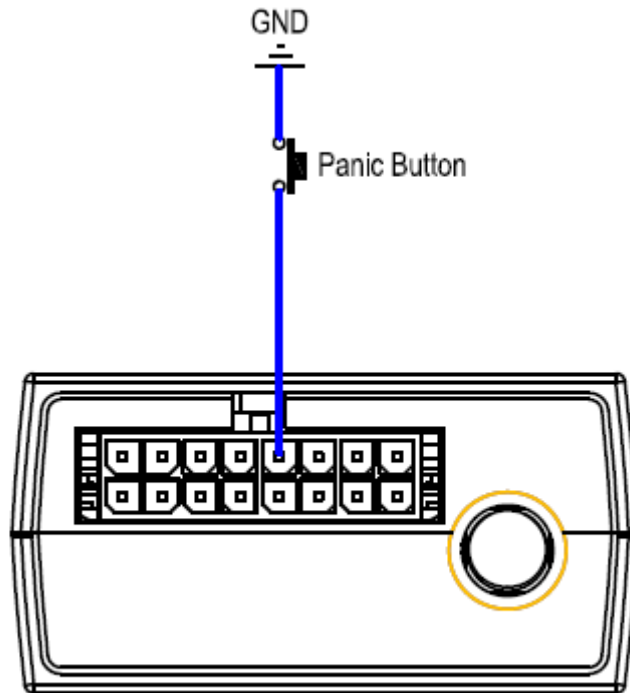

**Figure 11. Typical Digital Input Connection**

### 3.10. Analog Inputs

There are two analog inputs on GV300, and the analog input voltage range is from 0 to 16V. The following diagram shows the recommended connection.

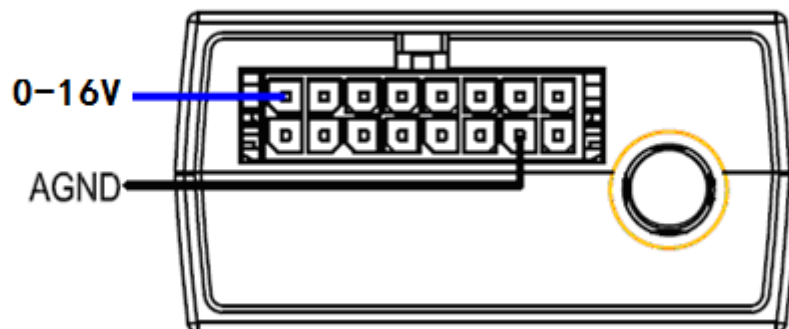

**Figure 12. Typical Analog Input Connection**

**Note:**

PIN 15 is a multifunction pin: it can be configured as a digital input or an analog input.

### 3.11. Digital Outputs

There are three digital outputs on GV300N. All are of open drain type and the maximum drain current is 150 mA. Each output has the built-in over current PTC resettable fuse.

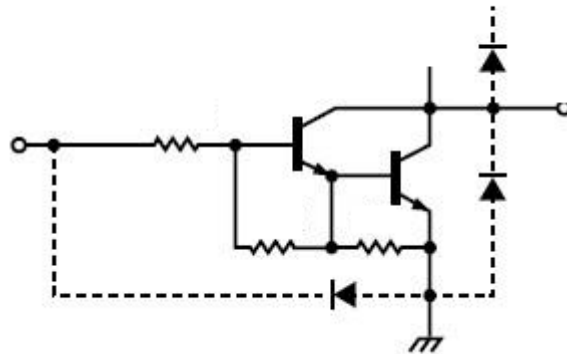

Figure 13. Digital Output Internal Drive Circuit

Table 9. Electrical Characteristics of Digital Outputs

Logical status	Electrical characteristics
Enable	<1.5V @150 mA
Disable	Open drain

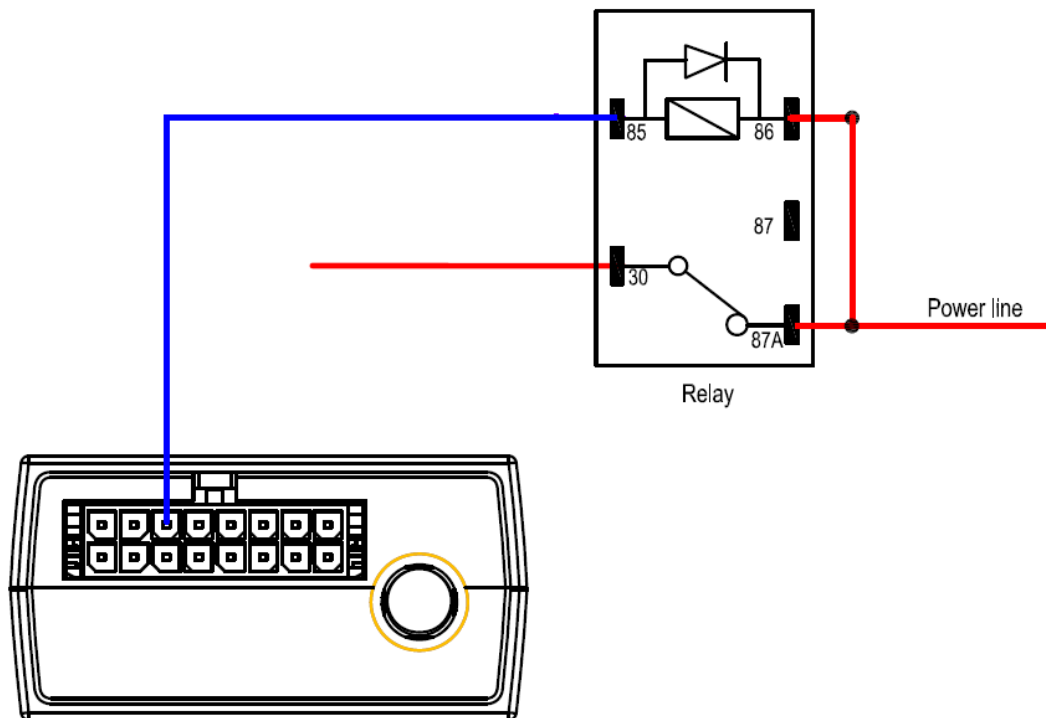
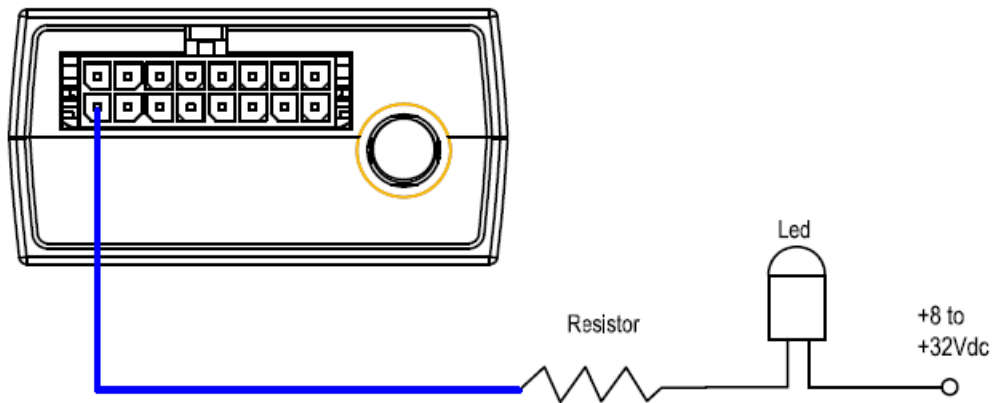

Figure 14. Typical Connection with Relay

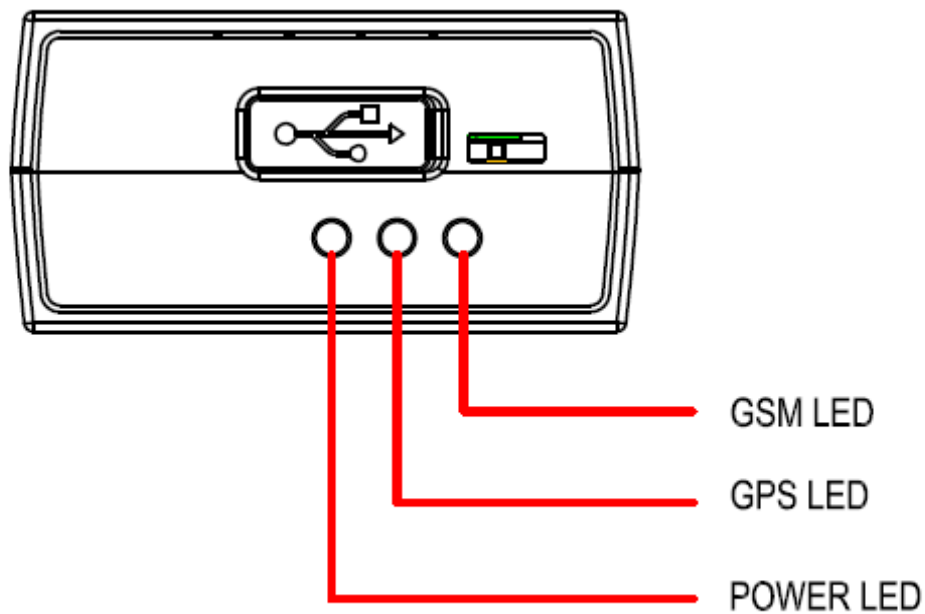

**Figure 15. Typical Connection with LED**

**Note:**

1. OUT1 will latch the output state during reset.
2. Many modern relays come with a flyback diode pre-installed internal to the relay itself. If the relay has this diode, ensure the relay polarity is properly connected. If this diode is not internal, it should be added externally. A common diode such as a 1N4004 will work in most circumstances.

### 3.12. Device Status LED



**Figure 16. GV300N LED on the Case**

LED	Device status	LED status
GSM (Note 1)	Device is searching GSM network.	Fast flashing (Note 3)
	Device has registered to GSM network.	Slow flashing (Note 4)
	SIM card needs pin code to unlock.	ON
GPS (Note 2)	GPS chip is powered off.	OFF
	GPS sends no data or data format error occurs.	Slow flashing
	GPS chip is searching GPS info.	Fast flashing
	GPS chip has gotten GPS info.	ON
PWR (Note 2)	No external power and internal battery voltage is lower than 3.35V.	OFF
	No external power and internal battery voltage is below 3.5V.	Slow flashing
	External power in and internal battery is charging.	Fast flashing
	External power in and internal battery is fully charged.	ON

**Table 10. Definition of Device Status and LED**

**Note:**

1. GSM LED cannot be configured.
2. GPS LED and PWR LED can be configured to turn off after a period of time by using the configuration tool.
3. Fast flashing is about 60 ms ON/780 ms OFF.
4. Slow flashing is about 60 ms ON/1940 ms OFF.

### 3.13. Serial Port/UART Interface

There are two lines dedicated to the Serial Port/UART interface (TXD and RXD). TXD/RXD are standard RS232 signal.

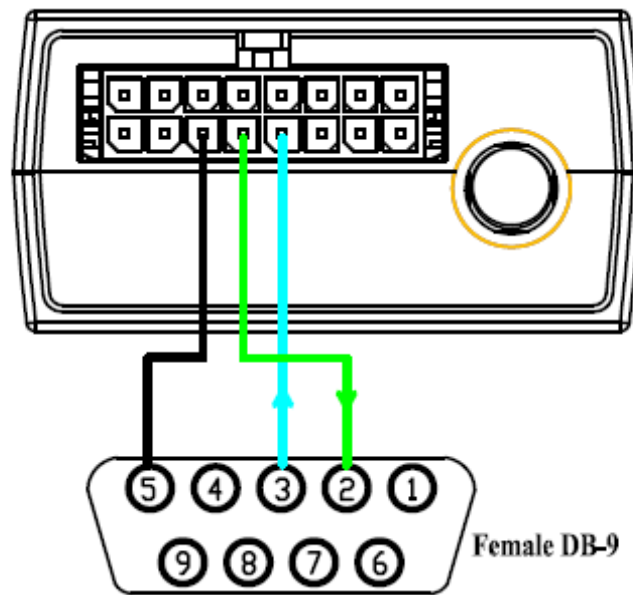

Figure 17. Typical Connection with RS232 Port

### 3.13.1. Connect with Garmin GPS Set

GV300N can communicate with Garmin GPS set. The following typical connection is using Queclink AG100 cable.



Figure 18. GV300 Connection with Garmin GPS Set

**Note:**

Some versions of GV300N can connect with Garmin GPS set by Garmin FMI10/FMI15 cable. Please consult Queclink for detail information.

### 3.13.2. Connect with CAN100 device

GV300N can communicate with CAN100 device only by RS232 port. The following picture shows the external interface of CAN100 device. Refer to Figure 19.

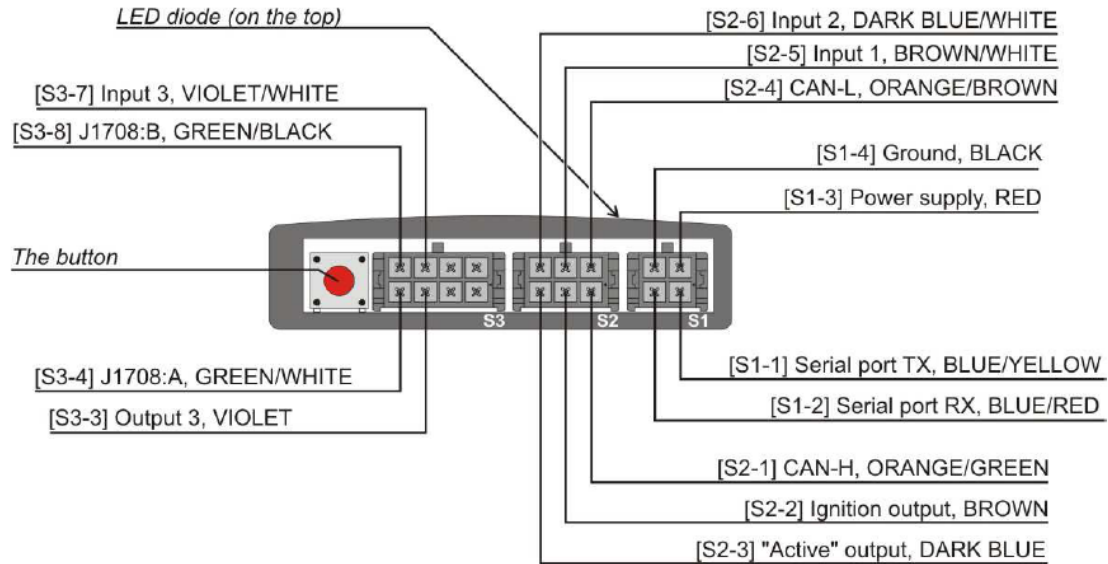

**Figure 19. The External Interface of CAN100 Device**

The following table 11 shows the definition of CAN100 device’s external interface .

Pin No.	Pin Name	Cable Color
S1-1	TX	Blue/Yellow
S1-2	RX	Blue/Red
S1-3	Power Supply	Red
S1-4	Ground	Black

**Table 11. External Interface of CAN100 Device**

The following Table 12 shows how to connect with the GV300N.

GV300N			Connection	CAN100		
Pin No.	Pin Name	Color		Pin No.	Pin Name	Color
4	RXD	Green or Pink	←-----→	S1-1	TX	Blue/Yellow
5	TXD	White/Black	←-----→	S1-2	RX	Blue/Red
11	Power	Red	←-----→	S1-3	Power Supply	Red
6	Ground	Black	←-----→	S1-4	Ground	Black

**Table 12. CAN100 Device Connects with GV300N**

Note:

1. As to how to distinguish the CAN100 device’s serial port is RS232 or TTL, please refer to CAN100 specification.