



CDMA2000-1X/GPS Tracker **GV300VC**

User Manual

Application Notes: TRACGV300VCUM001

Revision: 1.00



<http://www.queclink.com>

sales@queclink.com

Document Title	GV300VC User Manual
Version	1.00
Date	2014-09-01
Status	Release
Document Control ID	TRACGV300VCUM001

General Notes

Queclink offers this information as a service to its customers, to support application and engineering efforts that use the products designed by Queclink. The information provided is based upon requirements specifically provided to Queclink by the customers. Queclink has not undertaken any independent search for additional relevant information, including any information that may be in the customer's possession. Furthermore, system validation of this product designed by Queclink within a larger electronic system remains the responsibility of the customer or the customer's system integrator. All specifications supplied herein are subject to change.

Copyright

This document contains proprietary technical information which is the property of Queclink. Copying of this document, and giving it to others and the using or communication of the contents thereof, are forbidden without express authority. Offenders are liable to the payment of damages. All rights reserved in the event of grant of a patent or the registration of a utility model or design. All specifications supplied herein are subject to change without notice at any time.

Copyright © Queclink Wireless Solutions Co., Ltd. 2014

Contents

Contents	2
0. Revision History	6
1. Introduction	7
1.1 Reference	7
1.2 Terms and Abbreviations	7
2. Product Overview	8
2.1. Check Parts List	8
2.2. Parts List	9
2.3. Interface Definition	10
2.4. GV300VC User Cable Colour	11
3. Get Started	12
3.1. Open the Case	12
3.2. Close the Case	12
3.3. Install the Internal Backup Battery	13
3.4. Switch on the Backup Battery	13
3.5. Install the External GPS Antenna (Optional)	14
3.5.1. GPS Antenna Specification	14
3.6. Power Connection	14
3.7. Ignition Detection	15
3.8. Digital Inputs	16
3.9. Analog Inputs	17
3.10. Digital Outputs	17
3.11. Device Status LED	19
3.12. Serial Port/UART Interface	20

Table Index

TABLE 1.	GV300VC PROTOCOL REFERENCE.....	7
TABLE 2.	TERMS AND ABBREVIATIONS.....	7
TABLE 3.	PARTS LIST.....	9
TABLE 4.	DESCRIPTION OF 16 PIN CONNECTIONS.....	10
TABLE 5.	GV300VC USER CABLE COLOUR DEFINITION.....	11
TABLE 6.	GPS ANTENNA SPECIFICATION.....	14
TABLE 7.	ELECTRICAL CHARACTERISTICS OF IGNITION DETECTION	16
TABLE 8.	ELECTRICAL CHARACTERISTICS OF THE DIGITAL INPUTS	17
TABLE 9.	ELECTRICAL CHARACTERISTICS OF DIGITAL OUTPUTS.....	18
TABLE 10.	DEFINITION OF DEVICE STATUS AND LED	20

Figure Index

FIGURE 1.	APPEARANCE OF GV300VC.....	8
FIGURE 2.	THE 16 PIN CONNECTOR ON THE GV300VC.....	10
FIGURE 3.	OPEN THE CASE.....	12
FIGURE 4.	CLOSE THE CASE.....	12
FIGURE 5.	BACKUP BATTERY INSTALLATION	13
FIGURE 6.	SWITCH AND ON/OFF POSITION.....	13
FIGURE 7.	GPS ANTENNA OF GV300VC.....	14
FIGURE 8.	TYPICAL POWER CONNECTION.....	15
FIGURE 9.	TYPICAL IGNITION DETECTION.....	16
FIGURE 10.	TYPICAL DIGITAL INPUT CONNECTION	17
FIGURE 11.	TYPICAL ANALOG INPUT CONNECTION	17
FIGURE 12.	DIGITAL OUTPUT INTERNAL DRIVE CIRCUIT.....	18
FIGURE 13.	TYPICAL CONNECTION WITH RELAY	18
FIGURE 14.	TYPICAL CONNECTION WITH LED	19
FIGURE 15.	GV300VC LED ON THE CASE	19
FIGURE 16.	TYPICAL CONNECTION WITH RS232 PORT	21

0. Revision History

Revision	Date	Author	Description of change
1.00	2014-09-01	York Zhu	Initial

1. Introduction

The GV300VC is a compact GPS tracker designed for a wide variety of vehicle tracking applications. It has multiple I/O interfaces that can be used for monitoring or controlling external devices. Its built-in GPS receiver has superior sensitivity and fast time to first fix. Its dual band CDMA2000-1x allows the GV300VC's location to be monitored in real time or periodically tracked by a backend server and mobile devices. Its built-in 3-axis accelerometer allows driving behaviour monitoring, motion detection and extended battery life through sophisticated power management algorithms. System integration is straightforward as complete documentation is provided for the full featured @Track protocol. The @Track protocol supports a wide variety of reports including emergency, geo-fence boundary crossings, driving behaviour, low battery and scheduled GPS position.

1.1 Reference

Table 1. GV300VC Protocol Reference

SN	Document name	Remark
[1]	GV300VC @Track Air Interface Protocol	The air protocol interface between GV300VC and backend server.

1.2 Terms and Abbreviations

Table 2. Terms and Abbreviations

Abbreviation	Description
AGND	Analog Ground
AIN	Analog Input
DIN	Digital Input
DOUT	Digital Output
GND	Ground
RXD	Receive Data
TXD	Transmit Data
NC	No Connection

TRACGV300VCUM001

2. Product Overview

2.1 Check Parts List



Before starting, check whether all the following items have been included with your GV300. If anything is missing, please contact your supplier.



Figure 1. Appearance of GV300VC

2.2 Parts List

Table 3. Parts List

Name	Picture
GV300VC Locator	80*49*26 mm
User Cable	
GPS Antenna (Optional)	
DATA_CABLE_M (Optional)	

2.3 Interface Definition

The GV300 has a 16 PIN interface connector which contains the connections for power, I/O, RS232, etc. The sequence and definition of the 16PIN connector are shown in the following figure:

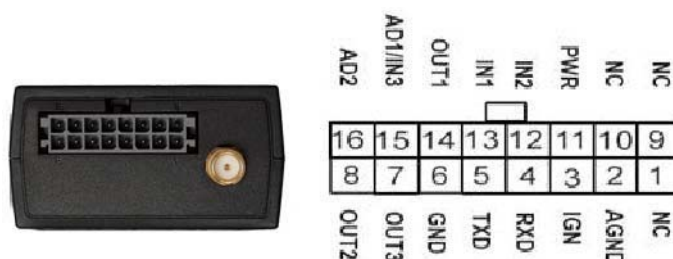

Figure 2. The 16 PIN Connector on the GV300VC

Table 4. Description of 16 PIN Connections

Index	Description	Comment
1	NC	Leave it floating
2	AGND	Analog ground
3	IGN	Ignition input, positive trigger
4	RXD	UART RXD, RS232
5	TXD	UART TXD, RS232
6	GND	Power and digital ground
7	OUT3	Open drain, 150 mA max
8	OUT2	Open drain, 150 mA max
9	NC	Leave it floating
10	NC	
11	PWR	External DC power input, 8-32V
12	IN2	Digital input, negative trigger
13	IN1	Digital input, negative trigger
14	OUT1	Open drain, 150 mA max ,with latch circuit
15	AD1/IN3	Multifunction input, analog or digital input 0-16V
16	AD2	Analog input 0.3-16v

TRACGV300VCUM001

2.4 GV300VC User Cable Colour**Table 5. GV300VC User Cable Colour definition**

Definition	Color	PIN No	Cable	PIN No	Color	Definition
OUT2	Yellow	8		16	Brown/White	AD2
OUT3	Brown	7		15	Green	AD1/IN3
GND	Black	6		14	Blue	OUT1
TXD	White/Black	5		13	Orange	IN1
RXD	Green or Pink	4		12	Orange/Black	IN2
IGN	White	3		11	Red	PWR
AGND	Gray/ Black	2		10	Purple/White	NC
NC	Gray	1		9	Purple	NC

3. Get Started

3.1 Open the Case

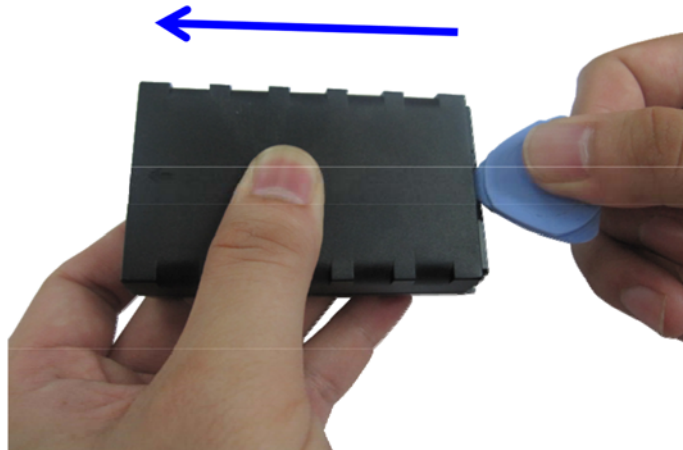

Figure 3. Open the Case

Insert the triangular-pry-opener into the gap of the case as shown above, and push the opener up until the case is unsnapped.

3.2 Close the Case



Figure 4. Close the Case

Place the cover on the bottom in the position as shown in the figure above. Slide the cover against the direction of the arrow until it snaps.

TRACGV300VCUM001

3.3 Install the Internal Backup Battery



Figure 5. Backup Battery Installation

GV300VC has an internal backup Li-ion battery.

3.4 Switch on the Backup Battery

To use the GV300VC backup battery, the switch must be in the ON position. The switch on the case and the ON/OFF position are shown below.

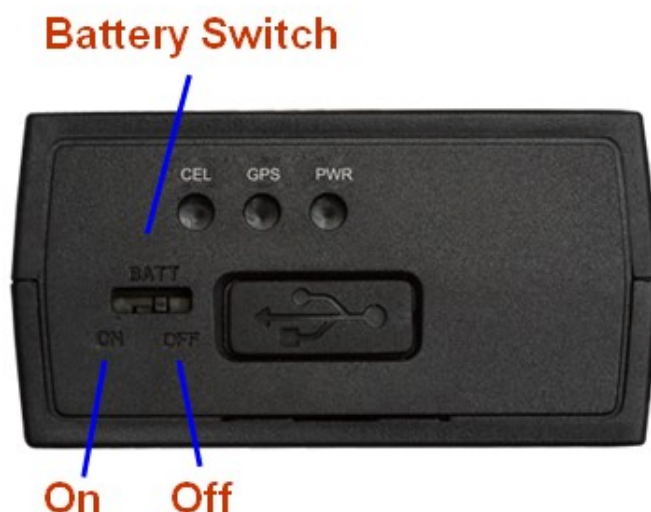

Figure 6. Switch and ON/OFF position

Note:

1. The switch must be in the “OFF” position when the GV300VC is shipped on an aircraft.
2. When the switch is in the “OFF” position, the battery cannot be charged or discharged.

3.5 Install the External GPS Antenna (Optional)

There is a SMA GPS antenna connector on GV300VC. The GV300VC will automatically detect and use an external antenna when connected.



Figure 7. GPS Antenna of GV300VC

3.5.1. GPS Antenna Specification

Table 6. GPS Antenna Specification

GPS antenna	Specification
Frequency	1575.42MHz
Bandwidth	>5 MHz
Beam width	>120 deg
Supply voltage	2.7V-3.3V
Polarization	RHCP
Gain	Passive: 0 dBi min Active: 15dB
Impedance	50Ω
VSWR	<2
Noise figure	<3

3.6 Power Connection

PWR (PIN12)/GND (PIN6) is the power input pin. The input voltage range for this device is from 8V to 32V. The device is designed to be installed in vehicles that operate on 12V or 24V systems without the need for external transformers.

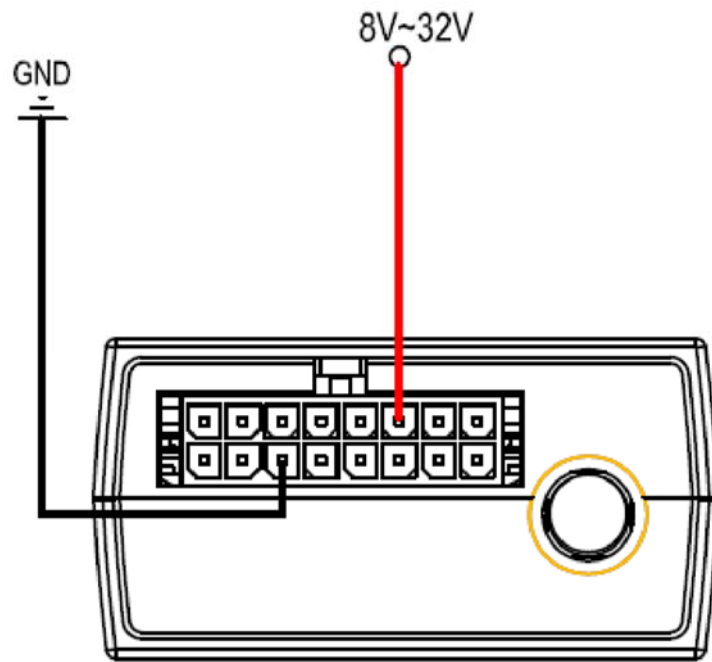

Figure 8. Typical Power Connection

3.7 Ignition Detection

Table 7. Electrical Characteristics of Ignition Detection

Logical status	Electrical characteristics
Active	5.0V to 32V
Inactive	0V to 3V or Open

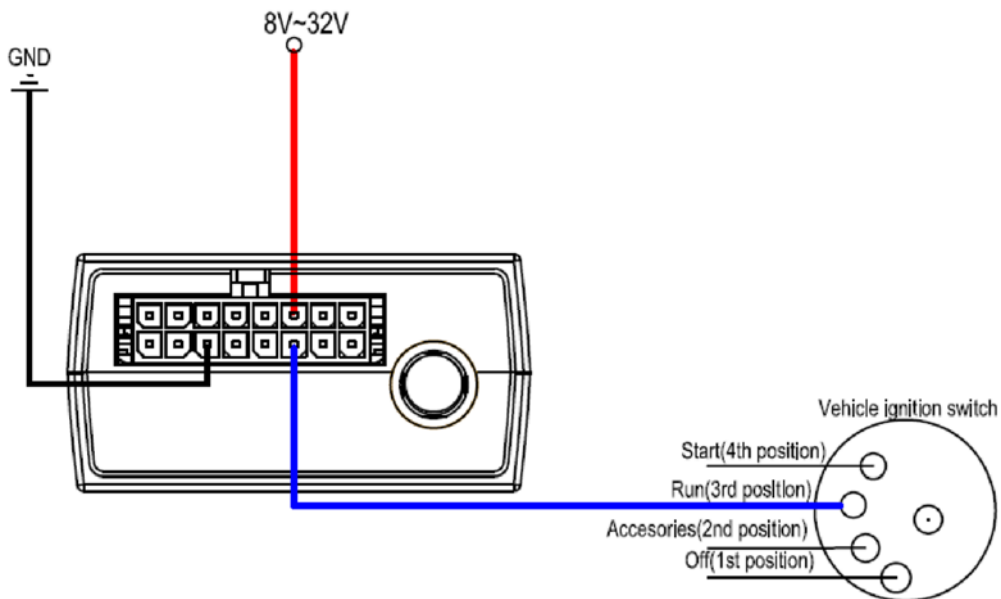

Figure 9. Typical Ignition Detection

IGN (Pin3) is used for ignition detection. It is strongly recommended to connect this pin to ignition key “RUN” position as shown above.

An alternative to connecting to the ignition switch is to find a non-permanent power source that is only available when the vehicle is running, for example, the power source for the FM radio. IGN signal can be configured to start transmitting information to the backend server when ignition is on, and enter the power saving mode when ignition is off.

There are three general purpose digital inputs on GV300VC. They are all negative trigger.

3.8 Digital Inputs

Table 8. Electrical Characteristics of the Digital Inputs

Logical status	Electrical characteristics
Active	0V to 0.8V
Inactive	Open

The following diagram shows the recommended connection of a digital input.

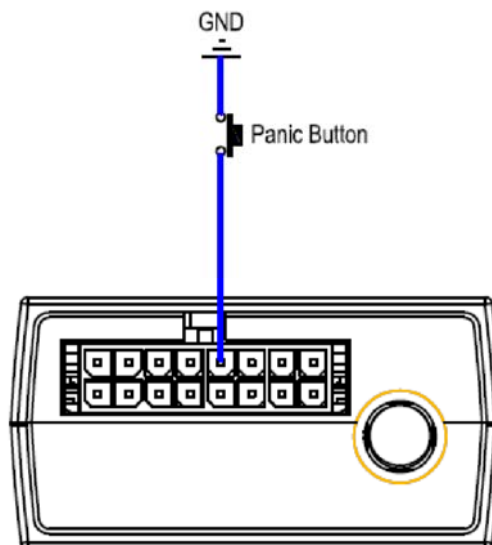

Figure 10. Typical Digital Input Connection

3.9 Analog Inputs

There are two analog inputs on GV300VC, and the analog input voltage range is from 0 to 16V. The following diagram shows the recommended connection.

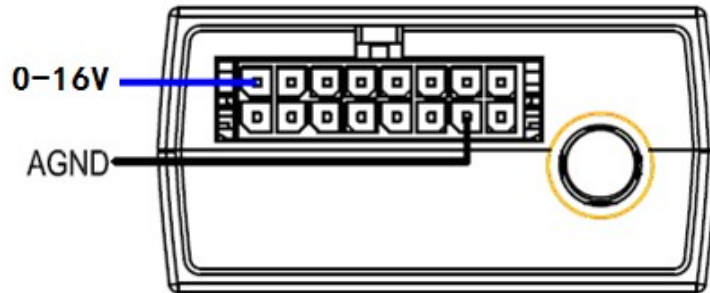

Figure 11. Typical Analog Input Connection

Note:

PIN 15 is a multifunction pin: it can be configured as a digital input or an analog input.

3.10 Digital Outputs

There are three digital outputs on GV300VC. All are of open drain type and the maximum drain current is 150 mA. Each output has the built-in over current PTC resettable fuse

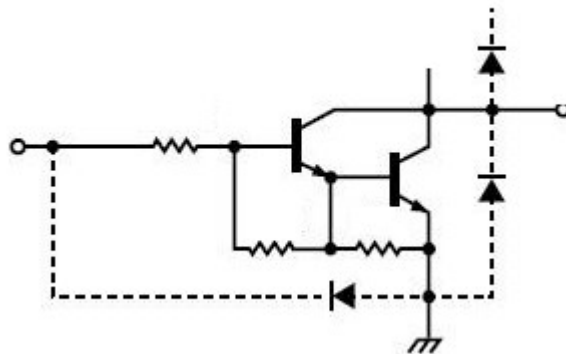

Figure 12. Digital Output Internal Drive Circuit

Table 9. Electrical Characteristics of Digital Outputs

Logical status	Electrical characteristics
Enable	<1.5V @150 mA
Disable	Open drain

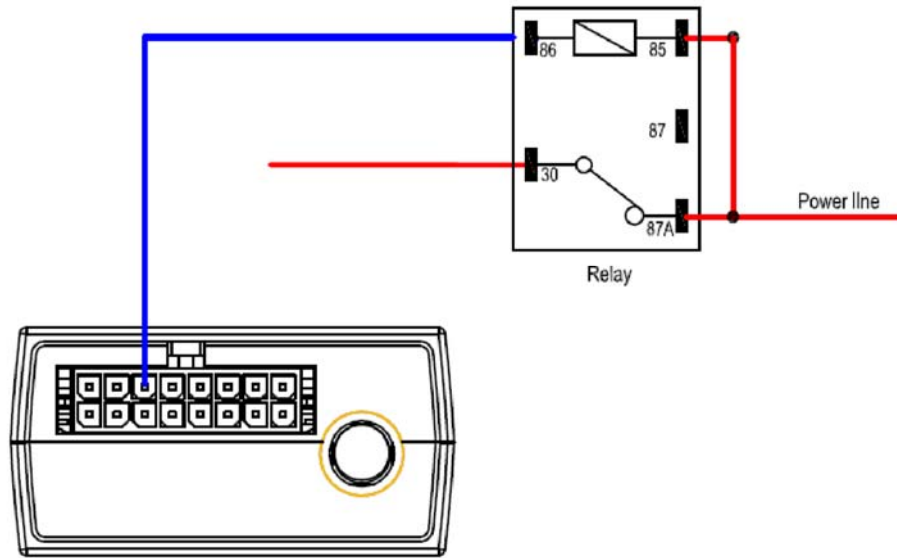

Figure 13. Typical Connection with Relay

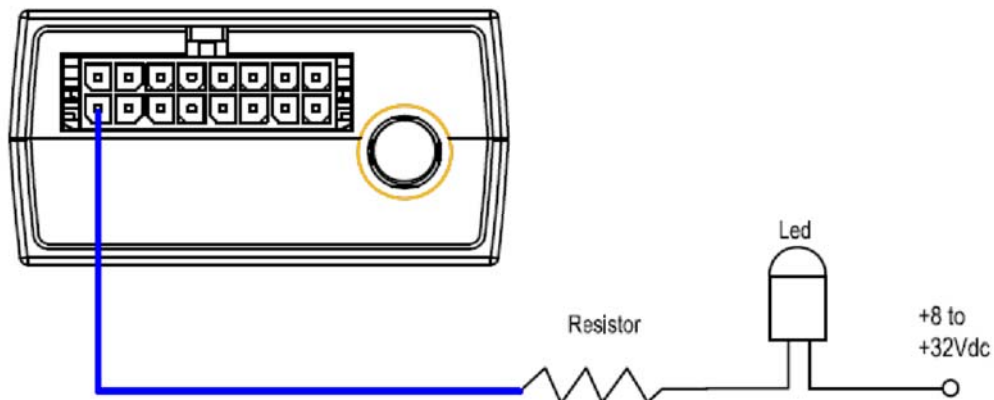

Figure 14. Typical Connection with LED

Note:

1. OUT1 will latch the output state during reset.
2. Many modern relays come with a flyback diode pre-installed internal to the relay itself. If the relay has this diode, ensure the relay polarity is properly connected. If this diode is not internal, it should be added externally. A common diode such as a 1N4004 will work in most circumstances.

3.11 Device Status LED

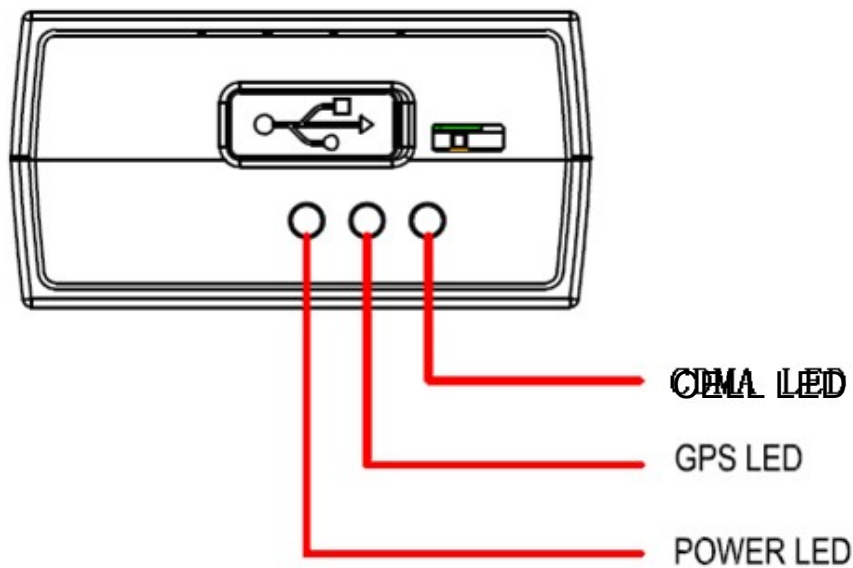

Figure 15. GV300VC LED on the Case

LED	Device status	LED status
CELL (note 1)	Device is searching CDMA2000 network.	Fast flashing (Note 3)
	Device has registered to CDMA2000 network.	Slow flashing (Note 4)
GPS (note 2)	GPS chip is powered off.	OFF
	GPS sends no data or data format error occurs.	Slow flashing
	GPS chip is searching GPS info.	Fast flashing
	GPS chip has gotten GPS info.	ON
PWR (note 2)	No external power and internal battery voltage is lower than 3.35V.	OFF
	No external power and internal battery voltage is below 3.5V.	Slow flashing

External power in and internal battery is charging.	Fast flashing
External power in and internal battery is fully charged.	ON

Table 10. Definition of Device Status and LED

Note:

1. CDMA2000 LED cannot be configured.
2. GPS LED and PWR LED can be configured to turn off after a period of time using the configuration tool
3. Fast flashing: for CELL LED is about 60 ms ON/780 ms OFF; for GPS LED and PWR LED is about 100 ms ON/100 ms OFF.
4. Slow flashing: for CELL LED is about 60 ms ON/1940 ms OFF; for GPS LED and PWR LED is about 600 ms ON/600 ms OFF.

3.12 Serial Port/UART Interface

There are two lines dedicated to the Serial Port/UART interface (TXD and RXD). TXD/RXD is standard RS232 signal.

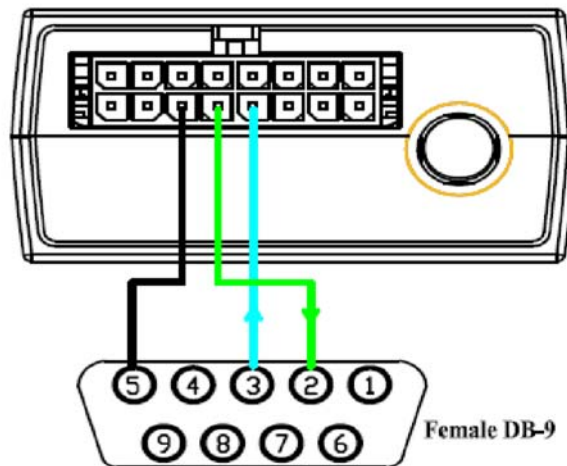

Figure 16. Typical Connection with RS232 Port

WARNING:

This device complies with part 15 of the FCC Rules. Operation is subject to the following two conditions:

- (1) This device may not cause harmful interference
- (2) This device must accept any interference received, including interference that may cause undesired operation.

Changes or modifications not expressly approved by the party responsible for compliance could void the user's authority to operate the equipment.

Note: This device has been tested and found to comply with the limits for a Class B digital device, pursuant to Part 15 of the FCC Rules. These limits are designed to provide reasonable protection against harmful interference in a residential installation. This equipment generates uses and can radiate radio frequency energy and, if not installed and used in accordance with the instructions, may cause harmful interference to radio communications. However, there is no guarantee that interference will not occur in a particular installation. If this equipment does cause harmful interference to radio or television reception, which can be determined by turning the equipment off and on, the user is encouraged to try to correct the interference by one or more of the following measures:

- Reorient or relocate the receiving antenna.
- Increase the separation between the equipment and receiver.
- Connect the equipment into an outlet on a circuit different from that to which the receiver is connected.
- Consult the dealer or an experienced radio/TV technician for help.