



GPS Locator **GV35** User Manual

TRACGV35UM001

Revision: 1.00



<http://www.queclink.com>

sales@queclink.com

Document Title	GV35 User Manual
Version	1.00
Date	2012-05-17
Status	Release
Document Control ID	TRACGV35UM001

General Notes

Queclink offers this information as a service to its customers, to support application and engineering efforts that use the products designed by Queclink. The information provided is based upon requirements specifically provided to Queclink by the customers. Queclink has not undertaken any independent search for additional relevant information, including any information that may be in the customer's possession. Furthermore, system validation of this product designed by Queclink within a larger electronic system remains the responsibility of the customer or the customer's system integrator. All specifications supplied herein are subject to change.

This device complies with part 15B, part 22 and part 24 of the FCC rules. Operation is subject to the following two conditions: (1) this device may not cause harmful interference (2) this device must accept any interference, including interference that may cause undesired operation.

WARNING:

Changes or modifications to this unit not expressly approved by the party responsible for compliance could void the user's authority to operate the equipment.

Users must maintain a separation distance of at least 20cm from the EUT to satisfy RF exposure compliance.

Copyright

This document contains proprietary technical information which is the property of Queclink Limited., copying of this document and giving it to others and the using or communication of the contents thereof, are forbidden without express authority. Offenders are liable to the payment of damages. All rights reserved in the event of grant of a patent or the registration of a utility model or design. All specification supplied herein are subject to change without notice at any time.

Copyright © Shanghai Queclink Wireless Solutions Co., Ltd. 2012

Contents

1. Introduction.....	7
1.1. Reference.....	7
1.2. Terms and Abbreviations.....	7
2. Product Overview	8
2.1. Check Part List.....	8
2.2. Parts List.....	9
2.3. Interface Definition	9
3. Getting Started	11
3.1. Opening the Case	11
3.2. Closing the Case.....	11
3.3. Installing a SIM Card	12
3.4. Power Connection	12
3.5. Ignition Detection.....	13
3.6. Digital Input	13
3.7. Digital Output.....	14
3.8. Relay	15
3.9. Device Status LED	16

Table Index

TABLE 1: GV35 PROTOCOL REFERENCE	7
TABLE 2: TERMS AND ABBREVIATIONS	7
TABLE 3: PART LIST	9
TABLE 4: DESCRIPTION OF 6 PIN CONNECTIONS	10
TABLE 5: ELECTRICAL CHARACTERISTICS OF IGNITION DETECTION.....	13
TABLE 6: ELECTRICAL CHARACTERISTICS OF THE DIGITAL INPUT	13
TABLE 7: ELECTRICAL CHARACTERISTICS OF DDIGITAL OUTPUT	15
TABLE 8: ELECTRICAL CHARACTERISTICS OF RELAY	15
TABLE 9: DEFINITION OF DEVICE STATUS AND LED	17

Figure Index

FIGURE 1.	APPEARANCE OF GV35	8
FIGURE 2.	THE 6 PIN CONNECTOR ON THE GV35.....	10
FIGURE 3.	OPENING THE CASE.....	11
FIGURE 4.	CLOSING THE CASE.....	11
FIGURE 5.	SIM CARD INSTALLATION.....	12
FIGURE 6.	TYPICAL POWER CONNECTION.....	12
FIGURE 7.	TYPICAL IGNITION DETECTION	13
FIGURE 8.	TYPICAL DIGITAL INPUT CONNECTION	14
FIGURE 9.	DIGITAL OUTPUT INTERNAL DRIVE CIRCUIT	14
FIGURE 10.	TYPICAL CONNECTION WITH LED	15
FIGURE 11.	TYPICAL CONNECTION WITH RELAY	16
FIGURE 12.	GV35 LED ON THE CASE.....	16

Revision History

Revision	Date	Author	Description of change
1.00	2012-5-17	Cid Xu	Initial

1. Introduction

The GV35 is a powerful GPS locator designed for vehicle or asset tracking. It has superior receiver sensitivity, fast TTFF (Time to First Fix) and supports Quad-Band GSM frequencies 850/900/1800/1900, its location can be monitored in real time or be periodically tracked by a backend server or other specified terminals. The GV35 has multiple input/output interfaces that can be used for monitoring or controlling external devices. Based on the integrated @Track protocol, the GV35 can communicate with a backend server through the GPRS/GSM network to transfer reports of Emergency, geo-fence boundary crossings, low backup battery or scheduled GPS position as well as many other useful functions. Users can also use GV35 to monitor the status of a vehicle and control the vehicle by its internal relay output. System Integrators can easily setup their tracking systems based on the full-featured @Track protocol.

1.1. Reference

Table 1: GV35 Protocol Reference

SN	Document name	Remark
[1]	GV35 @Track Air Interface Protocol	The air protocol interface between GV35 and backend server.

1.2. Terms and Abbreviations

Table 2: Terms and Abbreviations

Abbreviation	Description
GND	Ground
NC	Not Connected
IN1	Input Port
PWR	External DC power input
OUT1	Output Port
IGN	Ignition input

2. Product Overview

2.1. Check Part List

Before starting, check all the following items have been included with your GV35. If anything is missing, please contact your supplier.

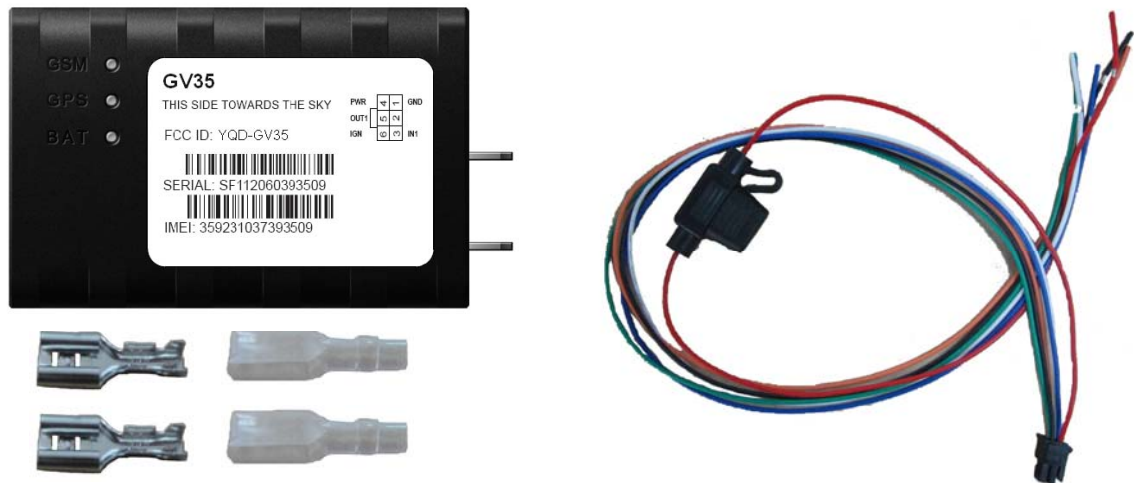





Figure 1. Appearance of GV35

2.2. Parts List

Table 3: Part List

Name	Picture
GV35 Locator	<p style="text-align: center;">74*49.5*24 mm</p> 
User Cable	
Relay Inserted spring	
Relay Inserted spring Protective sleeve	

2.3. Interface Definition

The GV35 has a 6 PIN interface connector. It contains the connections for power and I/O. The sequence and definition of the 6PIN connector are shown in following figure:

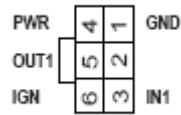

Figure 2. The 6 PIN connector on the GV35

Table 4: Description of 6 PIN Connections

Index	Description	Comment
1	GND	Ground
2	NC	
3	IN1	Digital input, negative trigger
4	PWR	External DC power input, 9-16V
5	OUT1	Open drain output signal(max drive current is 150mA)
6	IGN	Ignition input, positive trigger

3. Getting Started

3.1. Opening the Case



Figure 3. Opening the Case

Insert the triangular-pry-opener into the gap of the case as shown below, push the opener up until the case unsnapped.

3.2. Closing the Case



Figure 4. Closing the Case

Place the cover on the bottom in the position as shown in the following figure. Slide the cover follow the direction of the arrow until it snapped.

3.3. Installing a SIM Card

Open the case and ensure the unit is not powered (unplug the 6Pin cable and switch the internal battery to off position). Slide the holder right to open the SIM card. Insert the SIM card into the holder as shown below with the gold-colored contact area facing down taking care to align the cut mark. Close the SIM card holder. Close the case.

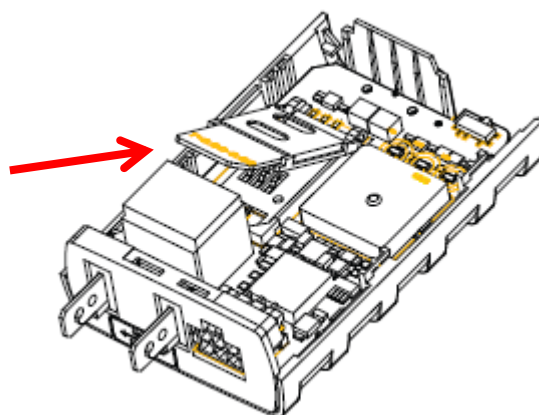

Figure 5. SIM Card Installation

3.4. Power Connection

PWR (PIN4) / GND (PIN1) are the power input pins. The input voltage range for this device is from 9V to 16V. The device is designed to be installed in vehicles that operate on 12V systems without the need for external transformers.

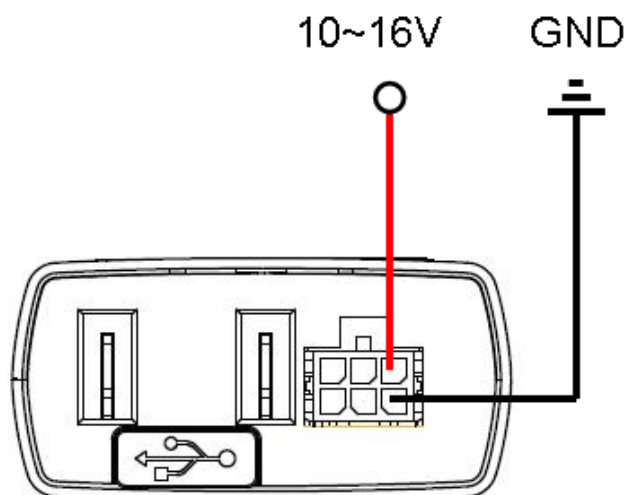

Figure 6. Typical Power Connection

3.5. Ignition Detection

Table 5: Electrical Characteristics of Ignition Detection

Logical State	Electrical State
Active	5.0V to 16V
Inactive	0V to 3V or Open

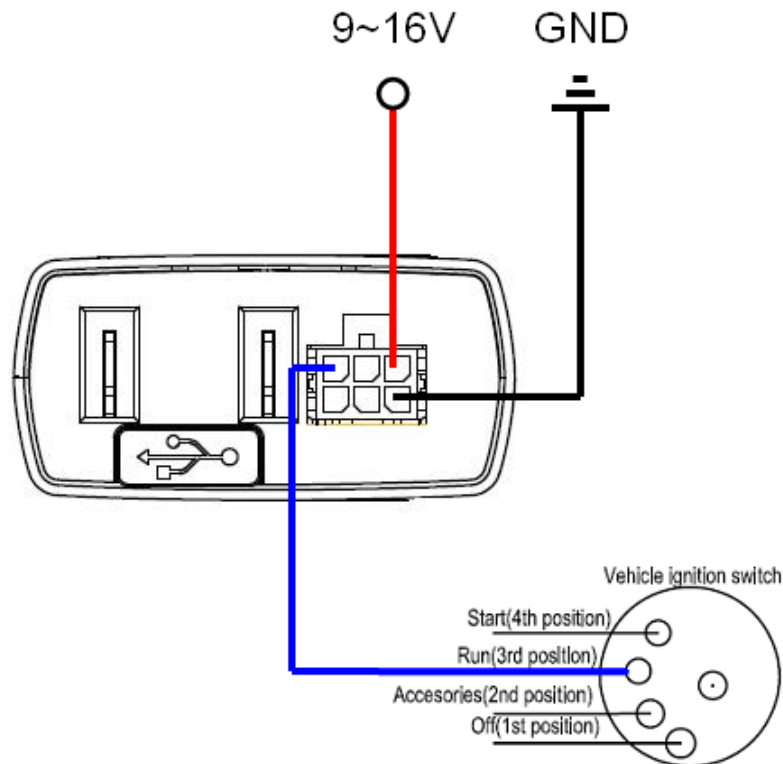

Figure 7. Typical Ignition Detection

IGN (Pin6) is used for ignition detection. It is strongly recommended to connect this pin to ignition key “RUN” position as shown up.

An alternative to connecting to the ignition switch is to find a non permanent power source that is only available when the vehicle is running. For example the power source for the FM radio.

IGN signal can be configured to start transmitting information to backend server when ignition is on; and enter power saving mode when ignition is off.

3.6. Digital Input

There is a general purpose digital input on GV35. It is negative trigger.

Table 6: Electrical Characteristics of the digital input

Logical State	Electrical Characteristics
Active	0V to 0.8V
Inactive	Open

The following diagram shows the recommended connection of a digital input.

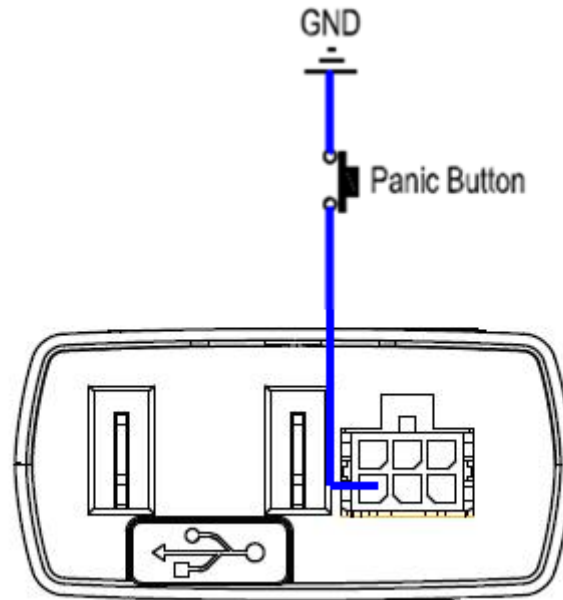

Figure 8. Typical Digital Input Connection

3.7. Digital Output

There is a digital output on GV35 which is open drain type and can latch the output status when there is no control. The output has a built-in over current and recovery PTC fuse and the maximum drain current is 150 mA.

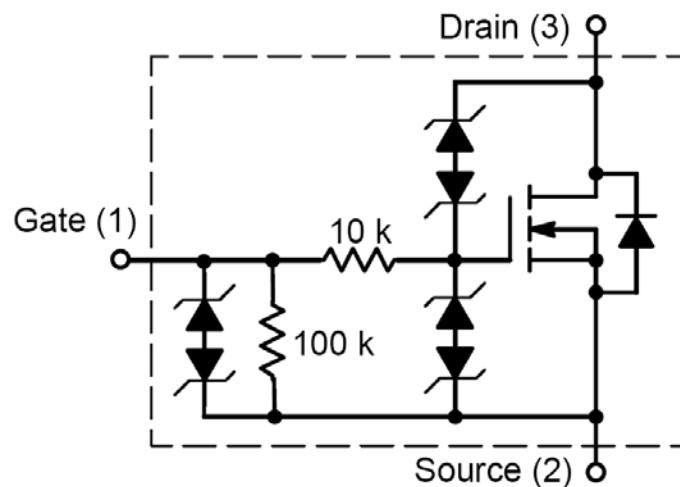
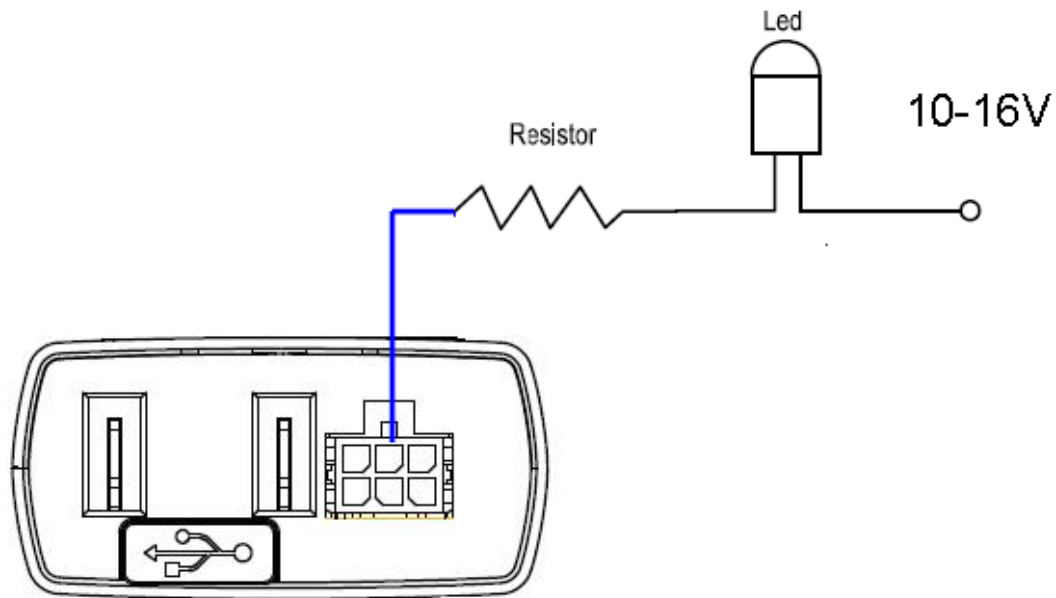

Figure 9. Digital Output Internal Drive Circuit

Table 7: Electrical Characteristics of Ddigital Output

Logical State	Electrical Characteristics
Enable	<1.5V @150mA
Disable	Open drain

**Figure 10. Typical Connection with LED**

Note:

1 - OUT1 will latch the output state during reset.

3.8. Relay

There is a built-in relay on GV35. The relay can latch the output statue when there is no control to relay. The rating load of the relay is 20A/14V..

Table 8: Electrical Characteristics of relay

Electrical Characteristics	
Max. Switching Power	280W
Max. Switching Voltage	18VDC
Max. Switching Current	25A
Contact Resistance	$\leq 100\text{m}\Omega$
Rating Load	20A/14VDC
Initial Insulation Resistance	Min. 100M Ω 500VDC

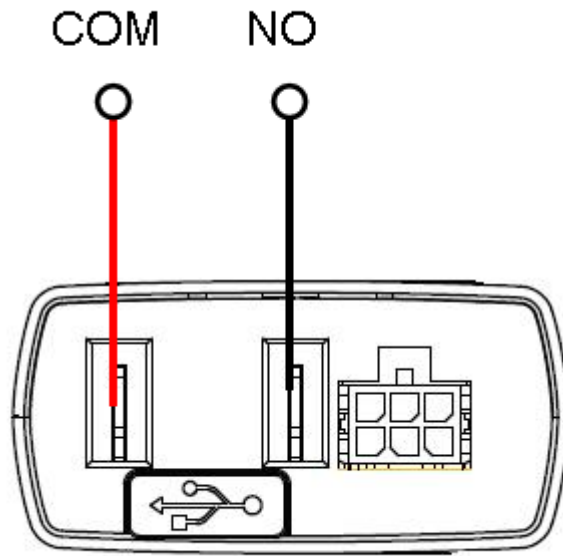

Figure 11. Typical Connection with relay

Note:

1 - Relay will latch the output state during reset.

3.9. Device Status LED

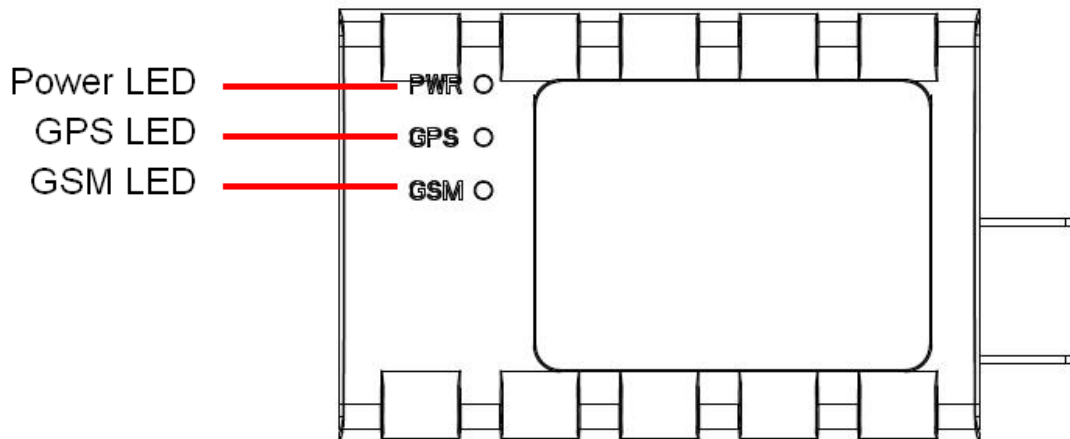

Figure 12. GV35 LED on the Case

Table 9: Definition of Device status and LED

LED	Device status	LED status
GSM (note1)	Device is searching GSM network	Fast flashing (Note3)
	Device has registered to GSM network.	Slow flashing (Note4)
GPS (note 2)	GPS chip is powered off	OFF
	GPS chip is searching GPS info.	OFF
	GPS chip has gotten GPS info.	ON
PWR (note 2)	No power	OFF
	power in	ON

Note:

1 - GSM LED cannot be configured.

2 - GPS LED and PWR LED can be configured to turn off after a period of time using the configuration tool

3 - Fast flashing is about 60ms ON/ 780ms OFF

4 - Slow flashing is about 60ms ON/ 1940ms OFF