



# CDMA2000-1X/GPS Tracker **GV55VC**

## User Manual

TRACGV55VCUM001

Revision: 1.00



<http://www.queclink.com>

[sales@queclink.com](mailto:sales@queclink.com)

Document Title	GV55VC User Manual
Version	1.00
Date	2014-10-30
Status	Release
Document Control ID	TRACGV55VCUM001

### General Notes

Queclink offers this information as a service to its customers, to support application and engineering efforts that use the products designed by Queclink. The information provided is based upon requirements specifically provided to Queclink by the customers. Queclink has not undertaken any independent search for additional relevant information, including any information that may be in the customer's possession. Furthermore, system validation of this product designed by Queclink within a larger electronic system remains the responsibility of the customer or the customer's system integrator. All specifications supplied herein are subject to change.

### Copyright

This document contains proprietary technical information which is the property of Queclink Limited., copying of this document and giving it to others and the using or communication of the contents thereof, are forbidden without express authority. Offenders are liable to the payment of damages. All rights reserved in the event of grant of a patent or the registration of a utility model or design. All specification supplied herein are subject to change without notice at any time.

*Copyright © Queclink Wireless Solutions Co., Ltd. 2014*

WARNING: This device complies with part 15 of the FCC Rules. Operation is subject to the following two conditions:

This device may not cause harmful interference, and

This device must accept any interference received, including interference that may cause undesired operation.

Changes or modifications not expressly approved by the party responsible for compliance could void the user's authority to operate the equipment.

FCC RF Exposure Statement:

For the product, under normal use condition is at least 20cm away from the body of the user, the user must keeping at least 20cm distance to the product.

**NOTE:**

This equipment has been tested and found to comply with the limits for a Class B digital device, pursuant to part 15 of the FCC Rules. These limits are designed to provide reasonable protection against harmful interference in a residential installation. This equipment generates, uses and can radiate radio frequency energy and, if not installed and used in accordance with the instructions, may cause harmful interference to radio communications. However, there is no guarantee that interference will not occur in a particular installation. If this equipment does cause harmful interference to radio or television reception, which can be determined by turning the equipment off and on, the user is encouraged to try to correct the interference by one or more of the following measures:

- Reorient or relocate the receiving antenna.
- Increase the separation between the equipment and receiver.
- Connect the equipment into an outlet on a circuit different from that to which the receiver is connected.
- Consult the dealer or an experienced radio/TV technician for help.

## Contents

1 Introduction.....	7
1.1. Reference .....	7
1.2. Terms and Abbreviations.....	7
2 Product Overview .....	8
2.1. Check Part List.....	8
2.2. Parts List .....	9
2.3. Interface Definition .....	9
2.4. GV55VC User Cable Colour .....	11
3 .Getting Started .....	12
3.1. Opening the Case .....	12
3.2. Closing the Case .....	12
3.3. Power Connection .....	13
3.4. Ignition Detection .....	13
3.5. Digital Inputs .....	14
3.6. Digital Outputs.....	14
3.7. Device Status LED.....	16
3.8. Motion Sensor direction.....	17

## Table Index

TABLE 1.	GV55VC PROTOCOL REFERENCE.....	7
TABLE 2.	TERMS AND ABBREVIATIONS.....	7
TABLE 3.	PART LIST.....	9
TABLE 4.	DESCRIPTION OF 6 PIN CONNECTIONS.....	10
TABLE 5.	GV55VC USER CABLE COLOUR DEFINITION.....	10
TABLE 6.	ELECTRICAL CHARACTERISTICS OF IGNITION DETECTION .....	12
TABLE 7.	ELECTRICAL CHARACTERISTICS OF THE DIGITAL INPUTS .....	13
TABLE 8.	ELECTRICAL CHARACTERISTICS OF DIGITAL OUTPUTS.....	14
TABLE 9.	DEFINITION OF DEVICE STATUS AND LED .....	16

### Figure Index

FIGURE 1.	APPEARANCE OF GV55VC.....	8
FIGURE 2.	THE 6 PIN CONNECTOR ON THE GV55VC.....	9
FIGURE 3.	OPENING THE CASE.....	11
FIGURE 4.	CLOSING THE CASE.....	11
FIGURE 5.	TYPICAL POWER CONNECTION.....	12
FIGURE 6.	TYPICAL IGNITION DETECTION.....	12
FIGURE 7.	TYPICAL DIGITAL INPUT CONNECTION .....	13
FIGURE 8.	DIGITAL OUTPUT INTERNAL DRIVE CIRCUIT.....	14
FIGURE 9.	TYPICAL CONNECTION WITH RELAY .....	14
FIGURE 10.	TYPICAL CONNECTION WITH LED .....	15
FIGURE 11.	GV55VC LED ON THE CASE .....	15
FIGURE 12.	MOTION SENSOR DIRECTION .....	17

**Revision History**

Revision	Date	Author	Description of change
1.00	2014-1-30	York Zhu	Initial

## 1 Introduction

The GV55VC is a powerful GPS locator designed for vehicle or asset tracking. It has superior receiver sensitivity, fast TTFF (Time to First Fix) and supports Dual-Band CDMA2000-1x frequencies 800/1900, its location can be monitored in real time or be periodically tracked by a backend server or other specified terminals. The GV55VC has multiple input/output interfaces that can be used for monitoring or controlling external devices. Based on the integrated @Track protocol, the GV55VC can communicate with a backend server through the CDMA2000-1x network to transfer reports of Emergency, geo-fence boundary crossings, low backup battery or scheduled GPS position as well as many other useful functions. Users can also use GV55VC to monitor the status of a vehicle and control the vehicle by its external relay output. System Integrators can easily setup their tracking systems based on the full-featured @Track protocol.

### 1.1. Reference

**Table 1. GV55VC Protocol Reference**

SN	Document name	Remark
[1]	GV55VC @Track Air Interface Protocol	The air protocol interface between GV55VC and backend server.

### 1.2. Terms and Abbreviations

**Table 2. Terms and Abbreviations**

Abbreviation	Description
AGND	Analog Ground
AIN	Analog Input
DIN	Digital Input
DOUT	Digital Output
GND	Ground
MIC	Microphone
RXD	Receive Data
TXD	Transmit Data
SPKN	Speaker Negative
SPKP	Speaker Positive

## 2 Product Overview

### 2.1. Check Part List

Before starting, check all the following items have been included with your GV55VC. If anything is missing, please contact your supplier.



**Figure 1. Appearance of GV55VC**





TRACGV55VCUM001

- 8 -

## 2.2. Parts List

**Table 3. Part List**

Name	Picture
GV55VC Locator	74mm*50mm*13.5mm
User Cable	
DATA_CABLE_M (Optional)	

## 2.3. Interface Definition

The GV55VC has a 6 PIN interface connector. It contains the connections for power, I/O. The sequence and definition of the 6PIN connector are shown in following figure:

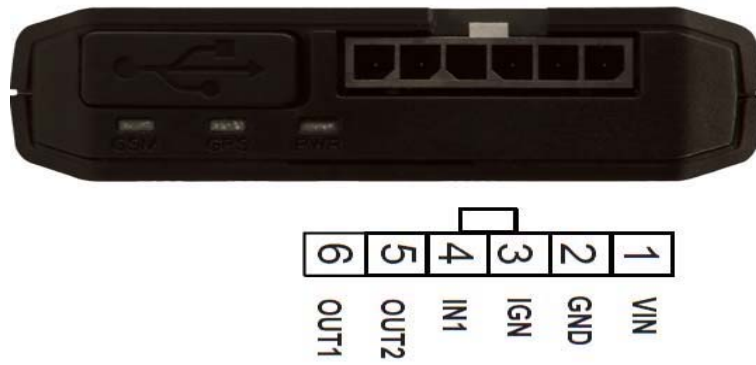

**Figure 2.** The 6 PIN connector on the GV55VC

**Table 4. Description of 6 PIN Connections**

Index	Description	Comment
1	VIN	External DC power input, 8-32V
2	GND	GND
3	IGN	Ignition input, positive trigger
4	IN1	Digital input, negative trigger
5	OUT2	Open drain, 150mA max
6	OUT1	Open drain, 150mA max ,with latch circuit

## 2.4. GV55VC User Cable Colour

**Table 5. GV55VC User Cable Colour definition**

Definition	Colour	PIN No	Cable
VIN	Red	1	
GND	Black	2	
IGN	White	3	
IN1	Orange	4	
OUT2	Green	5	
OUT1	Blue	6	

## 3 .Getting Started

### 3.1. Opening the Case



**Figure 3. Opening the Case**

Insert the triangular-pry-opener into the gap of the case as shown below, push the opener up until the case unsnapped.

### 3.2. Closing the Case



**Figure 4. Closing the Case**

Place the cover on the bottom in the position as shown in the following figure. Slide the cover against the direction of the arrow until it snapped.

### 3.3. Power Connection

VIN (PIN1) / GND (PIN2) are the power input pins. The input voltage range for this device is from 8V to 32V. The device is designed to be installed in vehicles that operate on 12V/24V vehicle without the need for external transformers.



Figure 5. Typical Power Connection

### 3.4. Ignition Detection

Table 6. Electrical Characteristics of Ignition Detection

Logical State	Electrical State
Active	5.0V to 32V
Inactive	0V to 3V or Open

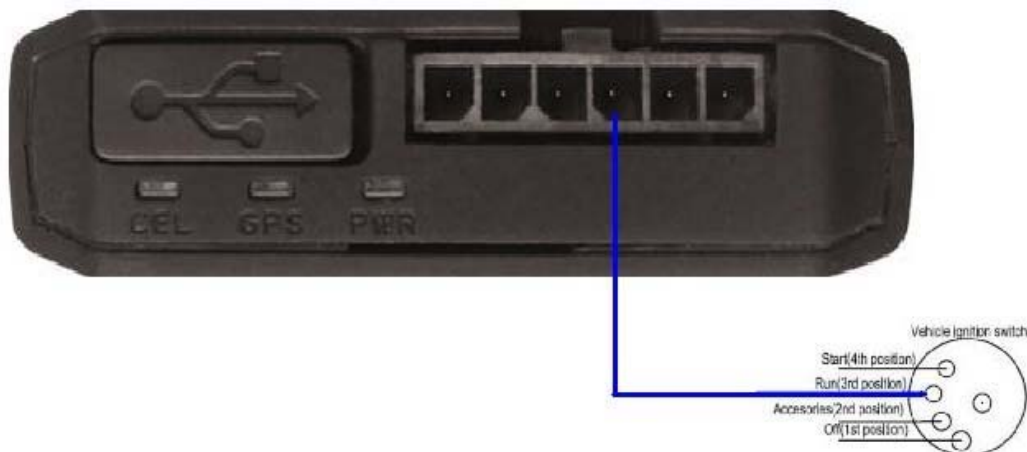

Figure 6. Typical Ignition Detection

IGN (Pin3) is used for ignition detection. It is strongly recommended to connect this pin to ignition key “RUN” position as shown up.

An alternative to connecting to the ignition switch is to find a non permanent power source that is only available when the vehicle is running. For example the power source for the

FM radio.

IGN signal can be configured to start transmitting information to backend server when ignition is on; and enter power saving mode when ignition is off.

### 3.5. Digital Inputs

There are one general purpose digital inputs on GV55VC. They are all negative trigger.

**Table 7. Electrical Characteristics of the digital inputs**

Logical State	Electrical Characteristics
Active	0V to 0.8V
Inactive	Open

The following diagram shows the recommended connection of a digital input.

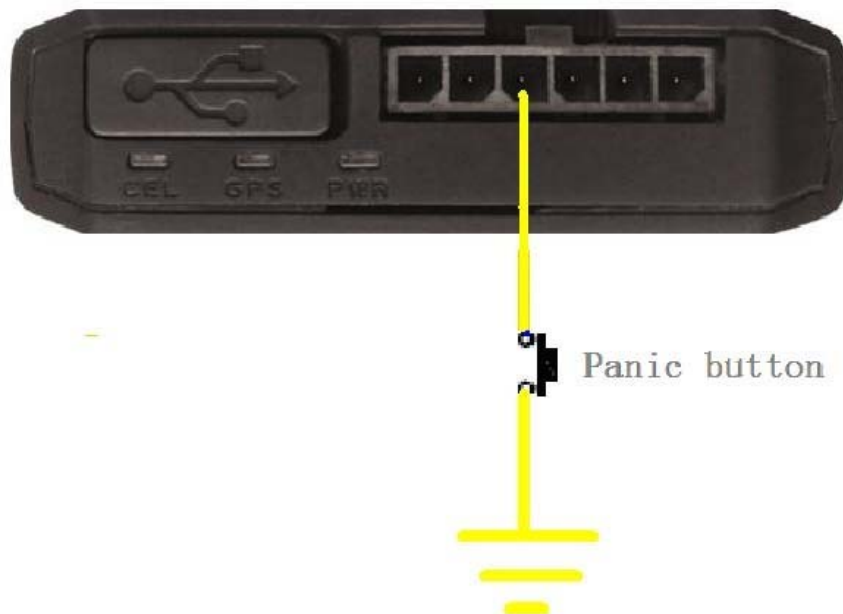

**Figure 7. Typical Digital Input Connection**

### 3.6. Digital Outputs

There are two digital outputs on GV55VC. All are of open drain type and the maximum drain current is 150mA. Each output has the built-in over current and recovery PTC fuse

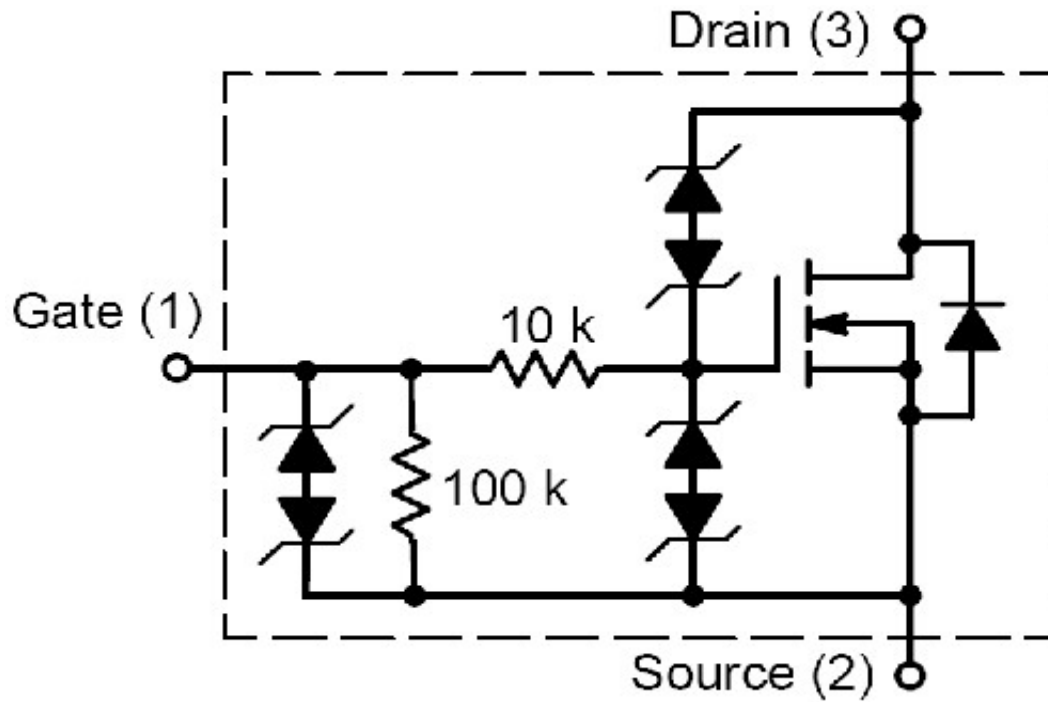
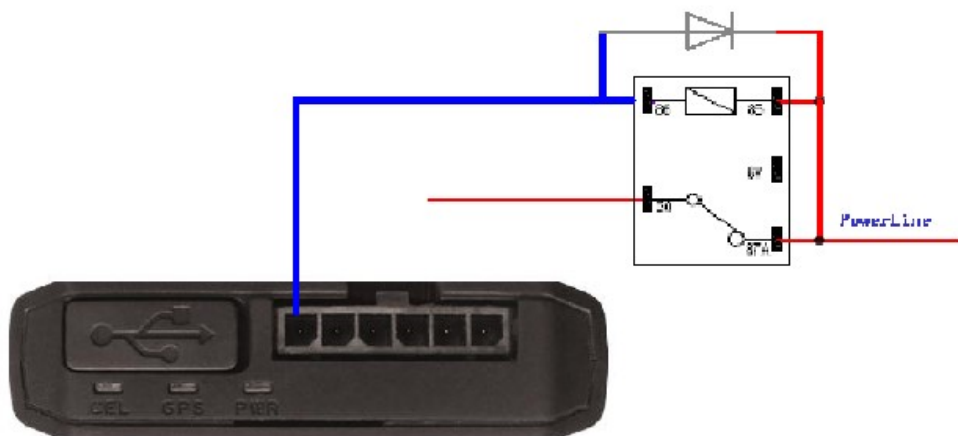

Figure 8. Digital Output Internal Drive Circuit

Table 8. Electrical Characteristics of Digital Outputs

Logical State	Electrical Characteristics
Enable	<1.5V @150mA
Disable	Open drain



**Figure 9. Typical Connection with Relay**

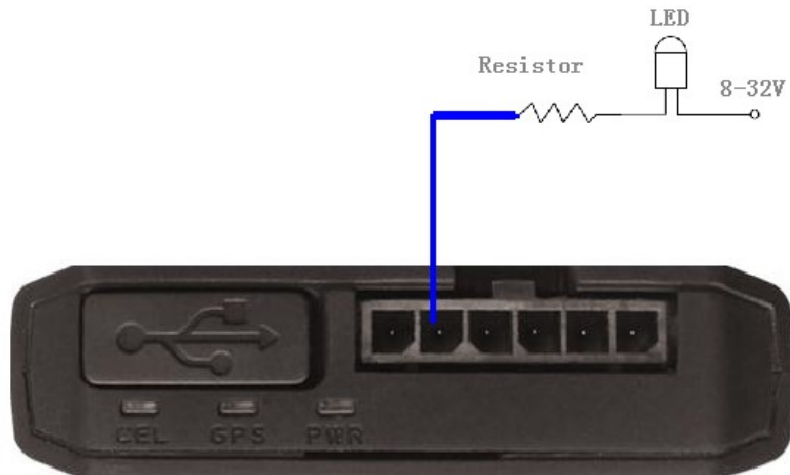
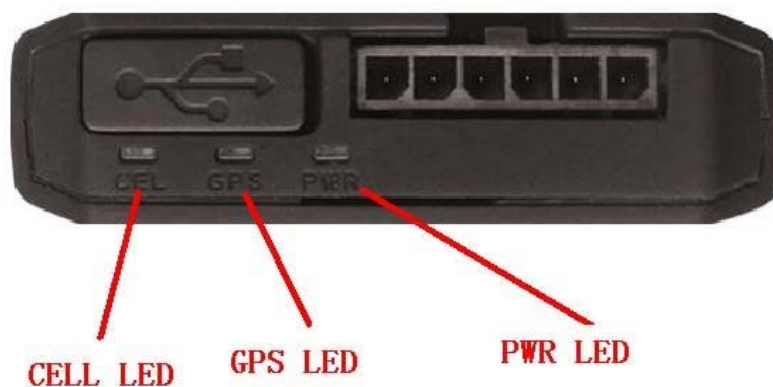

**Figure 10. Typical Connection with LED**

Note:

- 1 - OUT1 will latch the output state during reset.
- 2- Many modern relays come with a flyback diode pre-installed internal to the relay itself. If the relay has this diode, insure the proper relay polarity connected is used. If this diode is not internal, it should be added externally. A common diode such as a 1N4004 will work in most circumstances.

### 3.7. Device Status LED



**Figure 11. GV55VC LED on the Case**

GV55VC has three status led that CELL GPS PWR led.



**Table 9. Definition of Device status and LED**

CELL (note1)	Device is searching CELL network	Fast flashing
	Device has registered to CELL network.	Slow flashing
GPS (note 2)	GPS chip is powered off	OFF
	GPS sends no data or data format error	Slow flashing
	GPS chip is searching GPS info.	Fast flashing
	GPS chip has gotten GPS info.	ON
PWR (note 2)	No external power, and each time the device powers on, both LED's will work for 30 minutes and then are turned off deadly when LED ON is 0	OFF
	External power in and LED ON is 1	ON

**Note:**

- 1 – CELL LED cannot be configured.
- 2 - GPS LED and PWR LED can be configured to turn off after a period of time using the configuration tool
- 3 - Fast flashing is about 60ms ON/ 780ms OFF
- 4 - Slow flashing is about 60ms ON/ 1940ms OFF
- 5 –When LED ON is 0, each time the device powers on, both LED's will work for 30 minutes and then are turned off deadly

**3.8. Motion Sensor direction**

GV55VC has an internal 3-axis accelerometer supporting driving behavior monitoring, power conservation and motion detection. The following is the direction of the motion sensor.

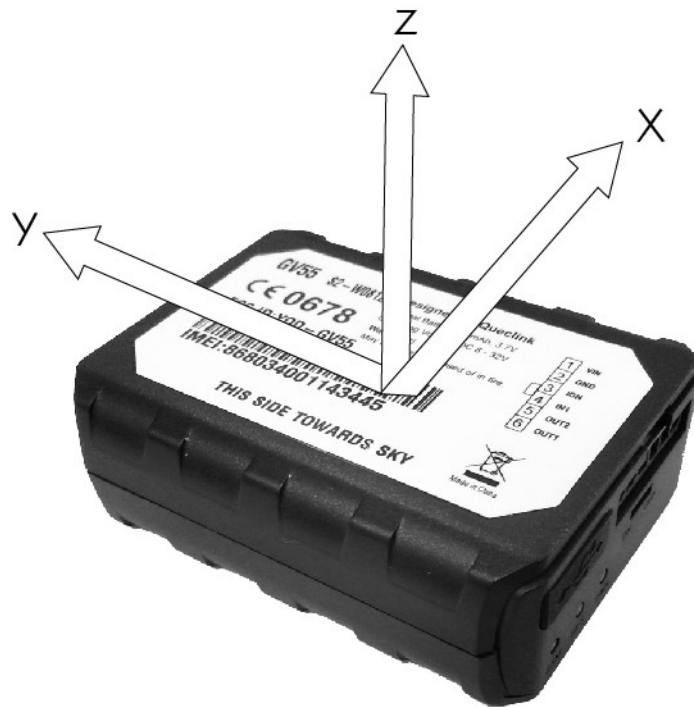

Figure 12. Motion sensor direction