

GV55W User Manual

Mini Vehicle Tracking Devices With Internal Battery

TRACGV55WUM001

Version: 1.00



International Telematics Solutions Innovator

Document Title	GV55W User Manual
Revision	1.00
Date	2018-02-08
Status	Release
Document Control ID	TRACGV55WUM001

General Notes

Queclink offers this information as a service to its customers, to support application and engineering efforts that use the products designed by Queclink. The information provided is based upon requirements specifically provided to Queclink by the customers. Queclink has not undertaken any independent search for additional relevant information, including any information that may be in the customer's possession. Furthermore, system validation of this product designed by Queclink within a larger electronic system remains the responsibility of the customer or the customer's system integrator. All specifications supplied herein are subject to change.

Copyright

This document contains proprietary technical information which is the property Queclink Wireless Solutions Co., Ltd. The copying of this document and giving it to others and the using or communication of the contents thereof, are forbidden without express authority. Offenders are liable to the payment of damages. All rights are reserved in the event of grant of a patent or the registration of a utility model or design. All specifications supplied herein are subject to change without notice at any time.

Contents

Contents	2
Table Index	3
Figure Index.....	4
0. Revision History.....	5
1. Introduction	6
1.1. Reference.....	6
1.2. Terms and Abbreviations	6
2. Product Overview.....	7
2.1. Check Parts List.....	7
2.2. Parts List	7
2.3. Interface Definition	8
2.4. GV55W User Cable Color.....	9
3. Getting Started	10
3.1. Open the Case	10
3.2. Close the Case	10
3.3. Install a SIM Card.....	11
3.4. Install the Internal Backup Battery.....	11
3.5. Switch ON the Backup Battery	12
3.6. Power Connection	12
3.7. Ignition Detection.....	13
3.8. Digital Input.....	14
3.9. Digital Outputs.....	14
3.10. Device Status LED	16
3.11. Motion Sensor Direction	18

Table Index

TABLE 1.	GV55W PROTOCOL REFERENCE	6
TABLE 2.	TERMS AND ABBREVIATIONS	6
TABLE 3.	PARTS LIST	7
TABLE 4.	DESCRIPTION OF 6 PIN CONNECTIONS	8
TABLE 5.	GV55W USER CABLE COLOR DEFINITION	9
TABLE 6.	ELECTRICAL CHARACTERISTICS OF IGNITION DETECTION.....	13
TABLE 7.	ELECTRICAL CHARACTERISTICS OF DIGITAL INPUT.....	14
TABLE 8.	ELECTRICAL CHARACTERISTICS OF DIGITAL OUTPUTS	15
TABLE 9.	DEFINITION OF DEVICE STATUS AND LED	17

Figure Index

FIGURE 1.	APPEARANCE OF GV55W	7
FIGURE 2.	6PIN CONNECTOR ON GV55W	8
FIGURE 3.	OPENING THE CASE	10
FIGURE 4.	CLOSING THE CASE	10
FIGURE 5.	SIM CARD INSTALLATION.....	11
FIGURE 6.	BACKUP BATTERY INSTALLATION.....	11
FIGURE 7.	SWITCH AND ON/OFF POSITION	12
FIGURE 8.	TYPICAL POWER CONNECTION	13
FIGURE 9.	TYPICAL IGNITION DETECTION	13
FIGURE 10.	TYPICAL DIGITAL INPUT CONNECTION	14
FIGURE 11.	DIGITAL OUTPUT INTERNAL DRIVE CIRCUIT.....	15
FIGURE 12.	TYPICAL CONNECTION WITH RELAY	15
FIGURE 13.	TYPICAL CONNECTION WITH LED.....	16
FIGURE 14.	GV55W LED ON THE CASE	17
FIGURE 15.	MOTION SENSOR DIRECTION	18

0.Revision History

Revision	Date	Author	Description of Change
1.00	2018-02-08	Alan Zhao	Initial

1. Introduction

GV55W is a powerful GPS locator designed for vehicle or asset tracking. It has superior receiver sensitivity, fast TTFF (Time to First Fix) and supports Dual-Band GSM frequencies 850/1900, its location can be monitored in real time or periodically tracked by a backend server or other specified terminals. GV55W has multiple input/output interfaces that can be used for monitoring or controlling external devices. Based on the integrated @Track protocol, the GV55W can communicate with a backend server through the GPRS network to transfer reports of emergency, geo-fence boundary crossings, low backup battery or scheduled GPS position as well as many other useful functions. Users can also use GV55W to monitor the status of a vehicle and control the vehicle by its external relay output. System Integrators can easily set up their tracking systems based on the full-featured @Track protocol.

1.1. Reference

Table 1. GV55W Protocol Reference

SN	Document name	Remark
[1]	GV55W @Track Air Interface Protocol	The air protocol interface between GV55W and backend server.

1.2. Terms and Abbreviations

Table 2. Terms and Abbreviations

Abbreviation	Description
AGND	Analog Ground
AIN	Analog Input
DIN	Digital Input
DOUT	Digital Output
GND	Ground
MIC	Microphone
RXD	Receive Data
TXD	Transmit Data
SPKN	Speaker Negative
SPKP	Speaker Positive

2. Product Overview

2.1. Check Parts List



Before starting, check all the following items have been included with your GV55W. If anything is missing, please contact your supplier.



Figure 1. Appearance of GV55W

2.2. Parts List

Table 3. Parts List

Name	Picture
GV55W Locator	63mm*50mm*21.8mm 
User Cable	

DATA_CABLE_W (Optional)	
-------------------------	--

2.3. Interface Definition

GV55W has a 6PIN interface connector. It contains the connections for power, and I/O. The sequence and definition of the 6PIN connector are shown in the following figure:

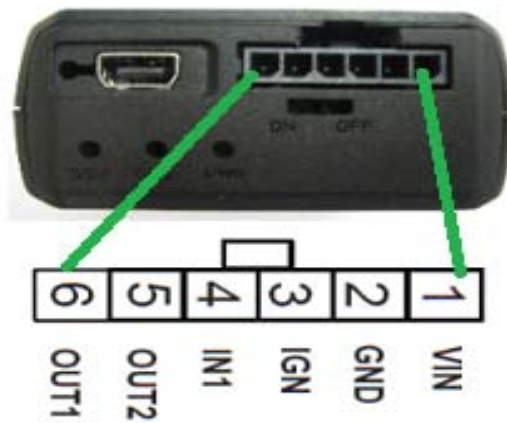

Figure 2. 6PIN Connector on GV55W

Table 4. Description of 6 PIN Connections

Index	Description	Remark
1	VIN	External DC power input, 12/24V
2	GND	GND
3	IGN	Ignition input, positive trigger
4	IN1	Digital input, negative trigger
5	OUT2	Open drain, 150mA max
6	OUT1	Open drain, 150mA max, with latch circuit

2.4. GV55W User Cable Color

Table 5. GV55W User Cable Color Definition

Definition	Color	PIN No.	Cable
VIN	Red	1	
GND	Black	2	
IGN	White	3	
IN1	Orange	4	
OUT2	Green	5	
OUT1	Blue	6	

3. Getting Started

3.1. Open the Case

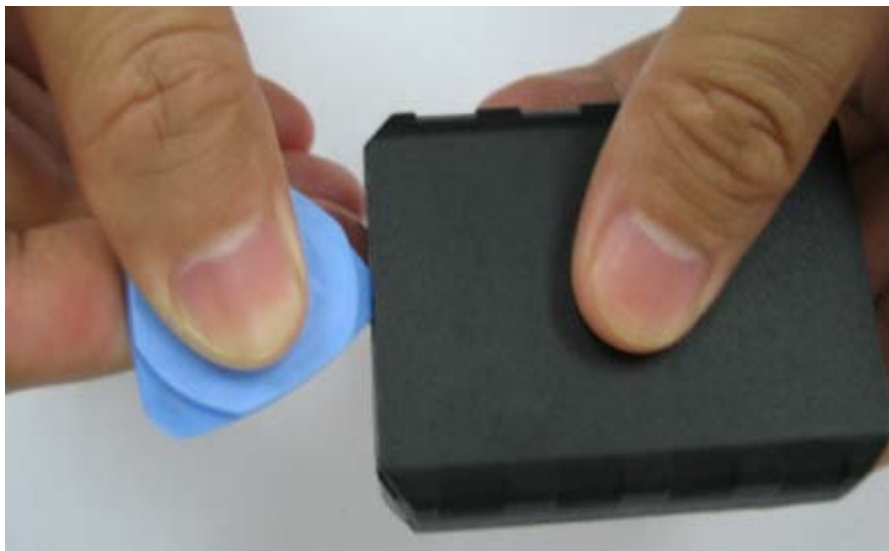

Figure 3. Opening the Case

Insert the triangular-pry-opener into the gap of the case as shown above, and push the opener up until the case unsnaps.

3.2. Close the Case



Figure 4. Closing the Case

Place the cover on the bottom. Gently slide the cover until it snaps.

3.3. Install a SIM Card

Open the case and ensure the unit is not powered (unplug the 6Pin cable and switch the internal battery to OFF position). Slide the holder right to open the SIM card. Insert the SIM card into the holder as shown below with the gold-colored contact area facing down. Take care to align the cut mark. Close the SIM card holder. Close the case.

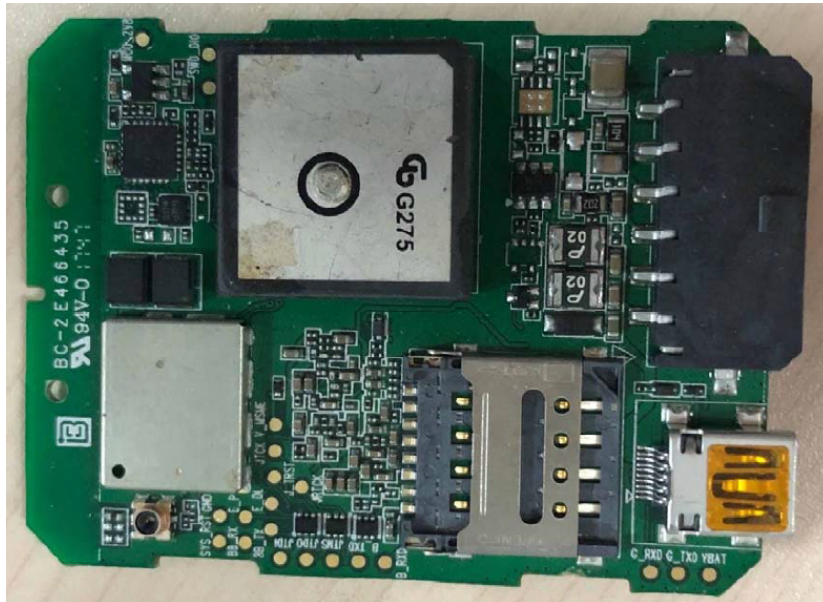

Figure 5. SIM Card Installation

3.4. Install the Internal Backup Battery



Figure 6. Backup Battery Installation

There is an internal backup Li-ion battery.

3.5. Switch ON the Backup Battery

To use the GV55W backup battery, the switch must be in the ON position. Switch and ON/OFF position are shown below.



Figure 7. Switch and ON/OFF position

Note:

1. The switch must be in the “OFF” position when shipped on an aircraft.
2. When the switch is in the “OFF” position, the battery cannot be charged or discharged.
3. To reset the device: Remove the external DC power and switch off the backup battery. Then supply the external power and switch on the backup battery.

3.6. Power Connection

PWR (PIN1) / GND (PIN2) are the power input pins. The input voltage range for this device is from 8-32V.

The device is designed to be installed in vehicles that operate on 12/24V vehicle without the need for external transformers.

n

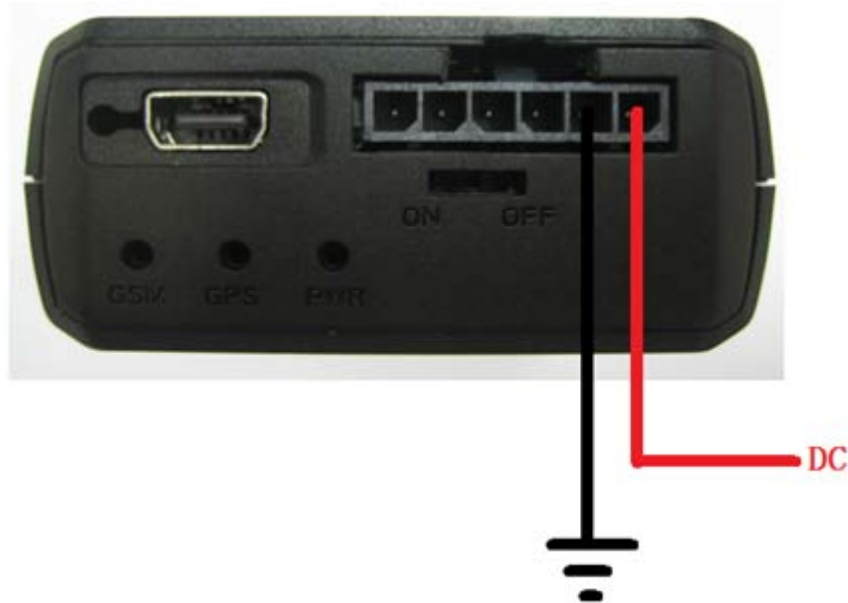

Figure 8. Typical Power Connection

3.7. Ignition Detection

Table 6. Electrical Characteristics of Ignition Detection

Logical State	Electrical State
Active	5.0V to 32V
Inactive	0V to 3V or Open



Figure 9. Typical Ignition Detection

IGN (Pin3) is used for ignition detection. It is strongly recommended to connect this pin to ignition key “RUN” position as shown above.

An alternative to connecting to the ignition switch is to find a non permanent power source that is only available when the vehicle is running. For example, the power source for the FM radio.

IGN signal can be configured for the device to start transmitting information to backend server when the ignition is on and enter power saving mode when the ignition is off.

3.8. Digital Input

There is one general purpose digital input on GV55W, i.e. IN1 (PIN3). It is negative trigger.

Table 7. Electrical Characteristics of Digital Input

Logical State	Electrical Characteristics
Active	0V to 0.8V
Inactive	Open

The following diagram shows the recommended connection of a digital input.



Figure 10. Typical Digital Input Connection

3.9. Digital Outputs

There are two digital outputs on GV55W. Both are of open drain type and the maximum drain current is 150mA. Each output has built-in overcurrent protection self-recovery PTC fuse.

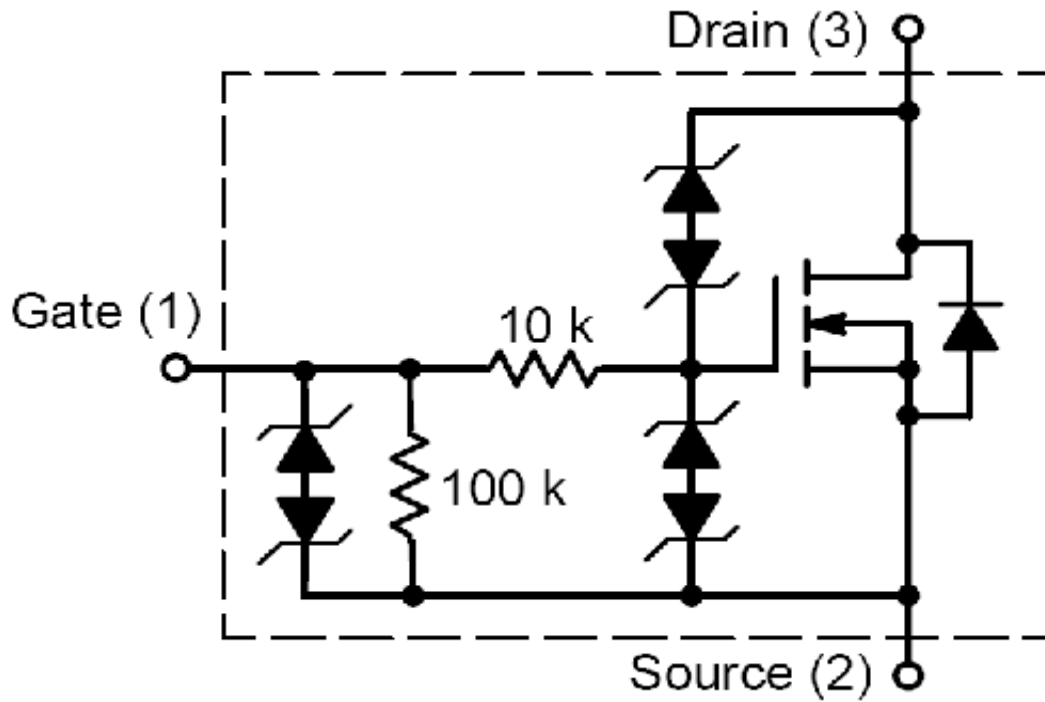

Figure 11. Digital Output Internal Drive Circuit

Table 8. Electrical Characteristics of Digital Outputs

Logical State	Electrical Characteristics
Enable	<1.5V @150mA
Disable	Open drain

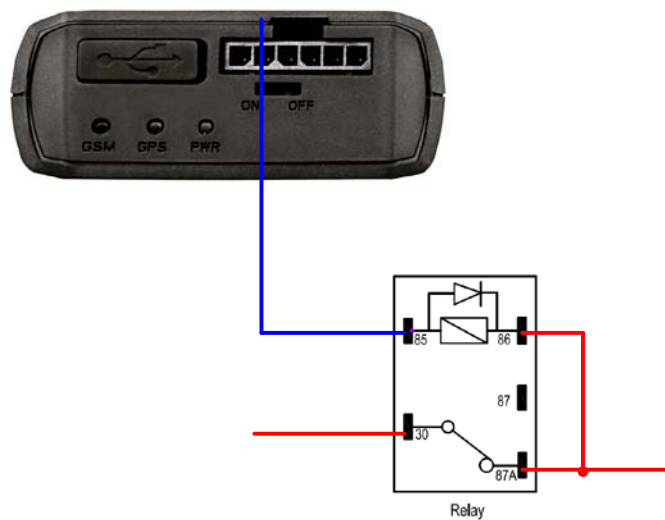

Figure 12. Typical Connection with Relay



Figure 13. Typical Connection with LED

Note:

1. OUT1 will latch the output state during reset.
2. Many modern relays come with a flyback diode pre-installed internal to the relay itself. If the relay has this diode, ensure the proper relay polarity connected is used. If this diode is not internal, it should be added externally. A common diode such as 1N4004 will work in most circumstances.

3.10. Device Status LED

GV55W has three status LEDs that are GSM LED, GPS LED, and PWR LED.

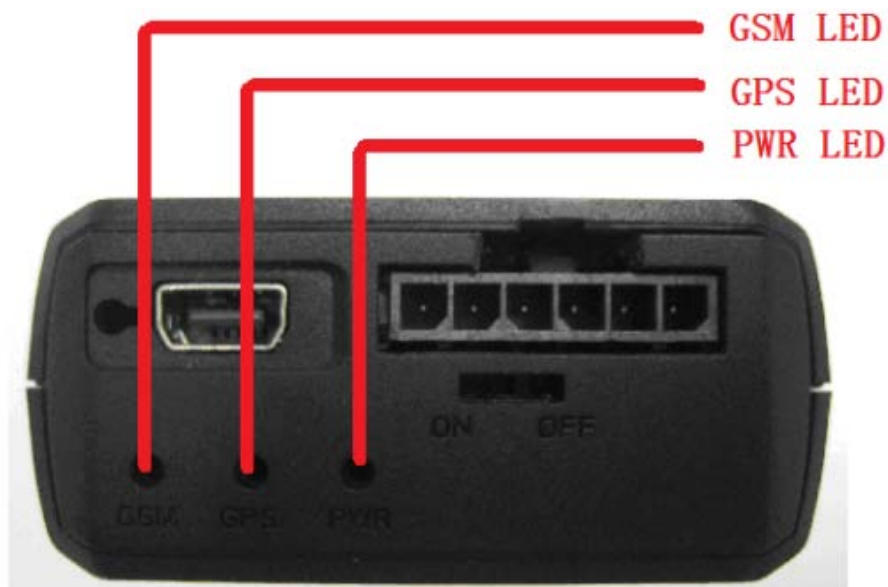

Figure 14. GV55W LED on the Case

Table 9. Definition of Device Status and LED

LED	Device Status	LED Status
GSM (Note 1)	Device is searching GSM network.	Fast flashing (Note 3)
	Device has registered to GSM network.	Slow flashing (Note 4)
	SIM card needs pin code to unlock.	ON
GPS (Note 2)	GPS chip is powered off.	OFF
	GPS sends no data or data format error occurs.	Slow flashing
	GPS chip is searching GPS information.	Fast flashing
	GPS chip has got GPS information.	ON
PWR (Note 2)	No external power and internal battery voltage is lower than 3.35V.	OFF
	No external power and internal battery voltage is in the range of 3.35V~3.5V.	Slow flashing
	External power in and internal battery is charging.	Fast flashing
	External power in and internal battery is fully charged.	ON

Note:

1. GSM LED cannot be configured.
2. GPS LED and PWR LED can be configured to turn off after a period of time using the configuration tool.
3. Fast flashing is about 60ms ON/780ms OFF.
4. Slow flashing is about 60ms ON/1940ms OFF.

3.11. Motion Sensor Direction

GV55W has an internal 3-axis accelerometer supporting driving behavior monitoring, power conservation and motion detection. The following shows the directions of the motion sensor.

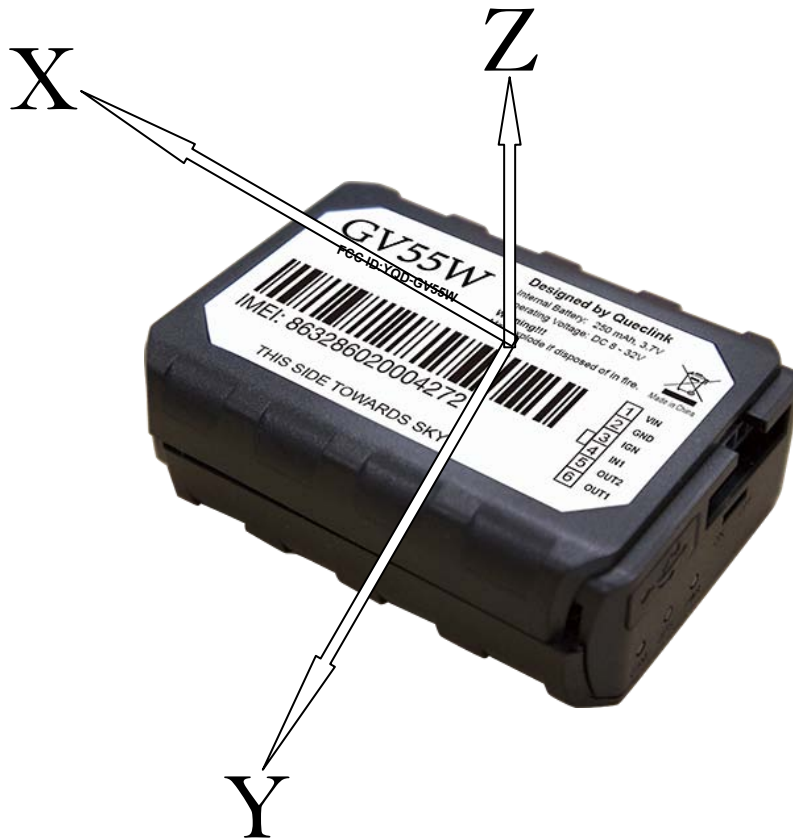

Figure 15. Motion Sensor Direction

FCC Statement

Any Changes or modifications not expressly approved by the party responsible for compliance could void the user's authority to operate the equipment.

This device complies with part 15 of the FCC Rules. Operation is subject to the following two conditions:

- (1) This device may not cause harmful interference, and
- (2) This device must accept any interference received, including interference that may cause undesired operation.

FCC Radiation Exposure Statement:

This equipment complies with FCC radiation exposure limits set forth for an uncontrolled environment. This equipment should be installed and operated with minimum distance 20cm between the radiator & your body.