

UC20 Hardware Design

UMTS/HSPA Module Series

Rev. UC20_Hardware_Design_V1.2

Date: 2014-01-13



Our aim is to provide customers with timely and comprehensive service. For any assistance, please contact our company headquarters:

Quectel Wireless Solutions Co., Ltd.

Office 501, Building 13, No.99, Tianzhou Road, Shanghai, China, 200233

Tel: +86 21 5108 6236

Mail: info@quectel.com

Or our local office, for more information, please visit:

<http://www.quectel.com/support/salesupport.aspx>

For technical support, to report documentation errors, please visit:

<http://www.quectel.com/support/techsupport.aspx>

GENERAL NOTES

QUECTEL OFFERS THIS INFORMATION AS A SERVICE TO ITS CUSTOMERS. THE INFORMATION PROVIDED IS BASED UPON CUSTOMERS' REQUIREMENTS. QUECTEL MAKES EVERY EFFORT TO ENSURE THE QUALITY OF THE INFORMATION IT MAKES AVAILABLE. QUECTEL DOES NOT MAKE ANY WARRANTY AS TO THE INFORMATION CONTAINED HEREIN, AND DOES NOT ACCEPT ANY LIABILITY FOR ANY INJURY, LOSS OR DAMAGE OF ANY KIND INCURRED BY USE OF OR RELIANCE UPON THE INFORMATION. THE INFORMATION SUPPLIED HEREIN IS SUBJECT TO CHANGE WITHOUT PRIOR NOTICE.

COPYRIGHT

THIS INFORMATION CONTAINED HERE IS PROPRIETARY TECHNICAL INFORMATION OF QUECTEL CO., LTD. TRANSMITTABLE, REPRODUCTION, DISSEMINATION AND EDITING OF THIS DOCUMENT AS WELL AS UTILIZATION OF THIS CONTENTS ARE FORBIDDEN WITHOUT PERMISSION. OFFENDERS WILL BE HELD LIABLE FOR PAYMENT OF DAMAGES. ALL RIGHTS ARE RESERVED IN THE EVENT OF A PATENT GRANT OR REGISTRATION OF A UTILITY MODEL OR DESIGN.

Copyright © Quectel Wireless Solutions Co., Ltd. 2014. All rights reserved.

About the Document

History

Revision	Date	Author	Description
1.0	2013-07-17	Mountain ZHOU	Initial
1.1	2013-08-29	Mountain ZHOU	<ol style="list-style-type: none"> 1. Updated USB driver information. 2. Added GNSS contents in Chapter 4. 3. Added GNSS current consumption. 4. Updated GNSS antenna requirements. 5. Released USIM_PRESENCE function.
1.2	2014-01-13	Mountain ZHOU	<ol style="list-style-type: none"> 1. Added UC20-G information. 2. Added AMR-WB feature. 3. Added USB upgrade test points' diagram. 4. Added reference design of transistor circuit on UART interface. 5. Deleted debug function of Debug UART interface. 6. Released AP_READY, UART upgrade function and Rx-diversity function. 7. Modified UC20-A frequency bands. 8. Modified W_DISABLE# definition. 9. Modified USIM pin's electrical characteristics. 10. Modified GNSS sensitivity definition. 11. Modified turning on timing figure. 12. Updated the sleep application in Chapter 3.5.1 and airplane mode in Chapter 3.5.2. 13. Updated I2C pins definition. 14. Updated current consumption.

Contents

About the Document	2
Contents	3
Table Index	6
Figure Index	7
1 Introduction	9
1.1. Safety Information.....	10
2 Product Concept	11
2.1. General Description.....	11
2.2. Directives and Standards.....	11
2.2.1. FCC Statement.....	12
2.2.2. FCC Radiation Exposure Statement.....	12
2.3. Key Features.....	12
2.4. Functional Diagram.....	15
2.5. Evaluation Board.....	16
3 Application Interface	17
3.1. General Description.....	17
3.2. Pin Assignment.....	18
3.3. Pin Description.....	19
3.4. Operating Modes.....	25
3.5. Power Saving.....	25
3.5.1. Sleep Mode.....	25
3.5.1.1. UART Application.....	26
3.5.1.2. USB Application with Suspend Function.....	26
3.5.1.3. USB Application without Suspend Function.....	27
3.5.2. Airplane Mode.....	28
3.6. Power Supply.....	29
3.6.1. Power Supply Pins.....	29
3.6.2. Decrease Voltage Drop.....	29
3.6.3. Reference Design for Power Supply.....	30
3.6.4. Monitor the Power Supply.....	31
3.7. Turn on and off Scenarios.....	31
3.7.1. Turn on Module Using the PWRKEY.....	31
3.7.2. Turn off Module.....	33
3.7.2.1. Turn off Module Using the PWRKEY Pin.....	33
3.7.2.2. Turn off Module Using AT Command.....	34
3.7.2.3. Automatic Shutdown.....	34
3.8. Reset the Module.....	35
3.9. RTC Backup.....	37

3.10.	UART Interface	38
3.11.	USIM Card Interface	42
3.11.1.	USIM Card Application	42
3.11.2.	Design Considerations for USIM Connector	44
3.12.	USB Interface	46
3.13.	PCM and I2C Interface	47
3.14.	ADC Function	50
3.15.	Network Status Indication	51
3.16.	Operating Status Indication	52
3.16.1.	STATUS	52
3.16.2.	SLEEP_IND	53
3.17.	Behavior of the RI	54
4	GNSS Receiver	55
4.1.	General Description	55
4.2.	GNSS Performance	56
4.3.	Layout Guideline	57
5	Antenna Interface	58
5.1.	UMTS Antenna Interface	58
5.1.1.	Pin Definition	58
5.1.2.	Operating Frequency	58
5.1.3.	Reference Design	58
5.2.	GNSS Antenna Interface	59
5.2.1.	Reference Design for Passive Antenna	60
5.2.2.	Reference Design for Active Antenna	61
5.3.	Antenna Installation	61
5.3.1.	Antenna Requirement	61
5.3.2.	Install the Antenna with RF Connector	62
6	Electrical, Reliability and Radio Characteristics	64
6.1.	Absolute Maximum Ratings	64
6.2.	Power Supply Ratings	65
6.3.	Operating Temperature	65
6.4.	Current Consumption	65
6.5.	RF Output Power	67
6.6.	RF Receiving Sensitivity	67
6.7.	Electrostatic Discharge	67
7	Mechanical Dimensions	69
7.1.	Mechanical Dimensions of the Module	69
7.2.	Footprint of Recommendation	72
7.3.	Top View of the Module	73
7.4.	Bottom View of the Module	73
8	Storage and Manufacturing	74
8.1.	Storage	74

8.2.	Manufacturing and Welding	74
8.3.	Packaging	75
9	Appendix A Reference.....	77

Table Index

TABLE 1: UC20 SERIES FREQUENCY BANDS	11
TABLE 2: UC20 KEY FEATURES	13
TABLE 3: IO PARAMETERS DEFINITION.....	19
TABLE 4: PIN DESCRIPTION	19
TABLE 5: OVERVIEW OF OPERATING MODES.....	25
TABLE 6: VBAT AND GND PINS.....	29
TABLE 7: PWRKEY PIN DESCRIPTION	31
TABLE 8: RESET_N PIN DESCRIPTION	35
TABLE 9: PIN DEFINITION OF THE MAIN UART INTERFACE.....	38
TABLE 10: PIN DEFINITION OF THE DEBUG UART INTERFACE.....	39
TABLE 11: LOGIC LEVELS OF DIGITAL I/O	39
TABLE 12: PIN DEFINITION OF THE USIM INTERFACE	42
TABLE 13: PIN DESCRIPTION OF MOLEX USIM CONNECTOR.....	44
TABLE 14: PIN DESCRIPTION OF AMPHENOL USIM CONNECTOR	45
TABLE 15: USB PIN DESCRIPTION	46
TABLE 16: PIN DEFINITION OF PCM AND I2C INTERFACE.....	49
TABLE 17: PIN DEFINITION OF THE ADC	50
TABLE 18: CHARACTERISTIC OF THE ADC	51
TABLE 19: PIN DEFINITION OF NETWORK INDICATOR.....	51
TABLE 20: WORKING STATE OF THE NETWORK INDICATOR.....	51
TABLE 21: PIN DEFINITION OF STATUS	52
TABLE 22: PIN DEFINITION OF SLEEP_IND	53
TABLE 23: BEHAVIOR OF THE RI	54
TABLE 24: GNSS PERFORMANCE	56
TABLE 25: PIN DEFINITION OF THE RF ANTENNA.....	58
TABLE 26: THE MODULE OPERATING FREQUENCIES.....	58
TABLE 27: PIN DEFINITION OF GNSS ANTENNA.....	59
TABLE 28: GNSS FREQUENCY.....	60
TABLE 29: ANTENNA REQUIREMENTS.....	62
TABLE 30: ABSOLUTE MAXIMUM RATINGS	64
TABLE 31: THE MODULE POWER SUPPLY RATINGS	65
TABLE 32: OPERATING TEMPERATURE.....	65
TABLE 33: THE MODULE CURRENT CONSUMPTION	66
TABLE 34: CONDUCTED RF OUTPUT POWER	67
TABLE 35: CONDUCTED RF RECEIVING SENSITIVITY.....	67
TABLE 36: ELECTROSTATICS DISCHARGE CHARACTERISTICS	68
TABLE 37: RELATED DOCUMENTS.....	77
TABLE 38: TERMS AND ABBREVIATIONS.....	77

Figure Index

FIGURE 1: FUNCTIONAL DIAGRAM.....	16
FIGURE 2: PIN ASSIGNMENT (TOP VIEW).....	18
FIGURE 3: UART SLEEP APPLICATION.....	26
FIGURE 4: USB APPLICATION WITH SUSPEND FUNCTION.....	27
FIGURE 5: USB SLEEP APPLICATION WITHOUT SUSPEND FUNCTION.....	28
FIGURE 6: STAR STRUCTURE OF THE POWER SUPPLY.....	30
FIGURE 7: REFERENCE CIRCUIT OF POWER SUPPLY.....	30
FIGURE 8: TURN ON THE MODULE USING DRIVING CIRCUIT.....	31
FIGURE 9: TURN ON THE MODULE USING KEYSTROKE.....	32
FIGURE 10: TIMING OF TURNING ON MODULE.....	33
FIGURE 11: TIMING OF TURNING OFF MODULE.....	34
FIGURE 12: REFERENCE CIRCUIT OF RESET_N BY USING DRIVING CIRCUIT.....	36
FIGURE 13: REFERENCE CIRCUIT OF RESET_N BY USING BUTTON.....	36
FIGURE 14: TIMING OF RESETTING MODULE.....	36
FIGURE 15: RTC SUPPLY FROM NON-CHARGEABLE BATTERY.....	37
FIGURE 16: RTC SUPPLY FROM RECHARGEABLE BATTERY.....	37
FIGURE 17: RTC SUPPLY FROM CAPACITOR.....	38
FIGURE 18: REFERENCE CIRCUIT WITH TRANSLATOR CHIP.....	40
FIGURE 19: REFERENCE CIRCUIT WITH TRANSISTOR CIRCUIT.....	40
FIGURE 20: RS232 LEVEL MATCH CIRCUIT.....	41
FIGURE 21: REFERENCE CIRCUIT OF DEBUG UART WITH LEVEL TRANSLATOR.....	41
FIGURE 22: REFERENCE CIRCUIT OF THE 8 PIN USIM CARD.....	42
FIGURE 23: REFERENCE CIRCUIT OF THE 6 PIN USIM CARD.....	43
FIGURE 24: MOLEX 91228 USIM CONNECTOR.....	44
FIGURE 25: AMPHENOL C707 10M006 512 2 USIM CARD CONNECTOR.....	45
FIGURE 26: REFERENCE CIRCUIT OF USB APPLICATION.....	46
FIGURE 27: TEST POINTS OF FIRMWARE UPGRADE.....	47
FIGURE 28: PRIMARY MODE TIMING.....	48
FIGURE 29: AUXILIARY MODE TIMING.....	49
FIGURE 30: REFERENCE CIRCUIT OF PCM APPLICATION WITH AUDIO CODEC.....	50
FIGURE 31: REFERENCE CIRCUIT OF THE NETWORK INDICATOR.....	52
FIGURE 32: REFERENCE CIRCUIT OF THE STATUS.....	53
FIGURE 33: REFERENCE CIRCUIT OF THE SLEEP_IND.....	54
FIGURE 34: REFERENCE CIRCUIT OF ANTENNA INTERFACE.....	59
FIGURE 35: REFERENCE CIRCUIT OF GNSS PASSIVE ANTENNA.....	60
FIGURE 36: REFERENCE CIRCUIT OF GNSS ACTIVE ANTENNA.....	61
FIGURE 37: DIMENSIONS OF THE UF.L-R-SMT CONNECTOR (UNIT: MM).....	62
FIGURE 38: MECHANICALS OF UF.L-LP CONNECTORS.....	63
FIGURE 39: SPACE FACTOR OF MATED CONNECTOR (UNIT: MM).....	63
FIGURE 40: UC20 TOP AND SIDE DIMENSIONS.....	69
FIGURE 41: UC20 BOTTOM DIMENSIONS (BOTTOM VIEW).....	70

FIGURE 42: BOTTOM PADS DIMENSIONS (BOTTOM VIEW) 71
FIGURE 43: RECOMMENDED FOOTPRINT (TOP VIEW) 72
FIGURE 44: TOP VIEW OF THE MODULE 73
FIGURE 45: BOTTOM VIEW OF THE MODULE 73
FIGURE 46: LIQUIDS TEMPERATURE 75
FIGURE 47: CARRIER TAPE 76

1 Introduction

This document defines the UC20 module and describes its hardware interface which are connected with your application and the air interface.

This document can help you quickly understand module interface specifications, electrical and mechanical details. Associated with application notes and user guide, you can use UC20 module to design and set up mobile applications easily.

1.1. Safety Information

The following safety precautions must be observed during all phases of the operation, such as usage, service or repair of any cellular terminal or mobile incorporating UC20 module. Manufacturers of the cellular terminal should send the following safety information to users and operating personnel and to incorporate these guidelines into all manuals supplied with the product. If not so, Quectel does not take on any liability for customer failure to comply with these precautions.



Full attention must be given to driving at all times in order to reduce the risk of an accident. Using a mobile while driving (even with a handsfree kit) cause distraction and can lead to an accident. You must comply with laws and regulations restricting the use of wireless devices while driving.



Switch off the cellular terminal or mobile before boarding an aircraft. Make sure it switched off. The operation of wireless appliances in an aircraft is forbidden to prevent interference with communication systems. Consult the airline staff about the use of wireless devices on boarding the aircraft, if your device offers a Airplane Mode which must be enabled prior to boarding an aircraft.



Switch off your wireless device when in hospitals or clinics or other health care facilities. These requests are desinged to prevent possible interference with sentitive medical equipment.



GSM cellular terminals or mobiles operate over radio frequency signal and cellular network and cannot be guaranteed to connect in all conditions, for example no mobile fee or an invalid SIM card. While you are in this condition and need emergent help, please remember using emergency call. In order to make or receive call, the cellular terminal or mobile must be switched on and in a service area with adequate cellular signal strength.



Your cellular terminal or mobile contains a transmitter and receiver. When it is ON , it receives and transmits radio frequency energy. RF interference can occur if it is used close to TV set, radio, computer or other electric equipment.



In locations with potentially explosive atmospheres, obey all posted signs to turn off wireless devices such as your phone or other cellular terminals. Areas with potentially exposive atmospheres including fuelling areas, below decks on boats, fuel or chemical transfer or storage facilities, areas where the air contains chemicals or particles such as grain, dust or metal powders.

2 Product Concept

2.1. General Description

UC20 is an embedded HSPA+ engine with Rx-diversity. Its UMTS-based modem provides data connectivity on HSPA+, HSDPA, HSUPA, WCDMA, networks. It can also provide GPS/GLONASS and voice functionality for customers' specific application. UC20 offers a maximum data rate of 14.4Mbps on downlink and 5.76Mbps on uplink in HSPA+/HSPA mode.

Table 1: UC20 Series Frequency Bands

Module	GSM 850	EGSM 900	DCS 1800	PCS 1900	UMTS 800	UMTS 850	UMTS 900	UMTS 1900	UMTS 2100	Rx- diversity	GNSS
UC20					✓			✓		✓	✓

With a tiny profile of 32.0mm × 29.0mm × 2.5mm, UC20 can meet almost all requirements for M2M application such as automotive, metering, tracking system, security solutions, routers, wireless POS, mobile computing devices, PDA phone and tablet PC, etc..

UC20 is an SMD type module, which can be embedded in application through its 112-pin pads including 72 LCC signal pads and 40 other pads.

UC20 is integrated with internet service protocols like TCP/UDP and PPP. Extended AT commands have been developed for customer to use these internet service protocols easily.

2.2. Directives and Standards

The UC20 module is designed to comply with the FCC statements. FCC ID: XMR-201312UC20
The Host system using UC20, should have label indicated FCC ID: XMR-201312UC20.

2.2.1. FCC Statement

1. This device complies with Part 15 of the FCC rules. Operation is subject to the following conditions:
 - a) This device may not cause harmful interference.
 - b) This device must accept any interference received, including interference that may cause undesired operation.
2. Changes or modifications not expressly approved by the party responsible for compliance could void the user's authority to operate the equipment.

2.2.2. FCC Radiation Exposure Statement

This equipment complies with FCC radiation exposure limits set forth for an uncontrolled environment. This equipment should be installed and operated with minimum distance 20cm between the radiator and your body as well as kept minimum 20cm from radio antenna depending on the Mobile status of this module usage. This module should NOT be installed and operating simultaneously with other radio.

The manual of the host system, which uses UC20, must include RF exposure warning statement to advice user should keep minimum 20cm from the radio antenna of UC20 module depending on the Mobile status.

Note: If a portable device (such as PDA) uses UC20 module, the device needs to do permissive change and SAR testing.

The following list of antenna is indicating the maximum permissible antenna gain.

Part Number	Frequency Range (MHz)	Peak Gain (XZ-V)	Average Gain (XZ-V)	VSWR	Impedance
3R007A	UMTS1900:1850~1990 UMTS850:824-894	1 dBi typ.	1 dBi typ.	3 max	50Ω

2.3. Key Features

The following table describes the detailed features of UC20 module.

Table 2: UC20 Key Features

Feature	Details
Power Supply	Supply voltage: 3.4V~4.3V Typical supply voltage: 3.8V
Frequency Bands	UC20-A: UMTS850/1900
Transmission Data	HSPA R6: Max 14.4Mbps (DL)/Max 5.76Mbps (UL) UMTS R99: Max 384kbps (DL)/Max 384kbps (UL) CSD: 14.4kbps
Transmitting Power	Class 3 (22.5dBm+1/-1dB) for UMTS 850/1900/
HSPA and UMTS Features	HSPA data rate is corresponded with 3GPP R6. 14.4Mbps on downlink and 5.76Mbps on uplink. WCDMA data rate is corresponded with 3GPP R99/R4. 384kbps on downlink and 384kbps on uplink. Support both 16-QAM and QPSK modulation.
Internet Protocol Features	Support TCP/PPP/UDP protocols Support the protocols PAP (Password Authentication Protocol) and CHAP (Challenge Handshake Authentication Protocol) usually used for PPP connections.
SMS	Text and PDU mode Point to point MO and MT SMS cell broadcast SMS storage: ME by default
USIM Interface	Support USIM/SIM card: 1.8V, 3.0V
Audio Features	Support one digital audio interface: PCM interface WCDMA: AMR/AMR-WB Echo cancellation and noise suppression
PCM Interface	Used for audio function with external codec. Support 8-bit A-law, μ -law and 16-bit linear data formats. Support long frame sync and short frame sync. Support master and slave mode, but must be the master in long frame sync.
UART Interface	Support two UART interfaces: main UART interface and debug UART interface

	<p>Main UART interface:</p> <ul style="list-style-type: none"> ● Seven lines on main UART interface ● Support RTS and CTS hardware flow control ● Baud rate can reach up to 921600bps, 115200bps by default ● Used for AT command, data transmission or firmware upgrade ● Multiplexing function <p>Debug UART interface:</p> <ul style="list-style-type: none"> ● Two lines on debug UART interface: DBG_TXD and DBG_RXD ● Can be used for GNSS NMEA sentences output
USB Interface	<p>Compliant with USB 2.0 specification (slave only), the data transfer rate can reach up to 480Mbps.</p> <p>Used for AT command communication, data transmission, GNSS NMEA output, software debug and firmware upgrade.</p> <p>USB Driver: Windows XP, Windows Vista, Windows 7, Windows 8, Windows CE5.0/6.0, Linux 2.6/3.0, Android 2.3/4.0.</p>
Rx-diversity	Support UMTS Rx-diversity
GNSS Features	Gen8 of Qualcomm GNSS engine (GPS and GLONASS) Protocol: NMEA 0183
AT Commands	Compliant with 3GPP TS 27.007, 27.005 and Quectel enhanced AT commands.
Real Time Clock	Implemented
Network Indication	Two pins including NET_MODE and NET_STATUS to indicate network connectivity status.
Antenna Interface	Include main UMTS antenna, UMTS diversity antenna, GNSS antenna (passive).
Physical Characteristics	Size: 32.0±0.15 × 29.0±0.15 × 2.5±0.2mm Weight: approx. 4.9g
Temperature Range	Normal operation: -35°C ~ +75°C Restricted operation: -40°C ~ -35°C and +75°C ~ +85°C ¹⁾ Storage temperature: -45°C ~ +90°C
Firmware Upgrade	USB interface (by default) or main UART interface.
RoHS	All hardware components are fully compliant with EU RoHS directive.

NOTE

“1)” means when the module works within this temperature range, RF performance might degrade. For example, the frequency error or the phase error would increase.

2.4. Functional Diagram

The following figure shows a block diagram of UC20 and illustrates the major functional parts.

- Power management
- Baseband
- DDR+NAND flash
- Radio frequency
- Peripheral interface
 - UART interface
 - USIM card interface
 - USB interface
 - PCM interface
 - ADC interface
 - Status indication
 - Control interface

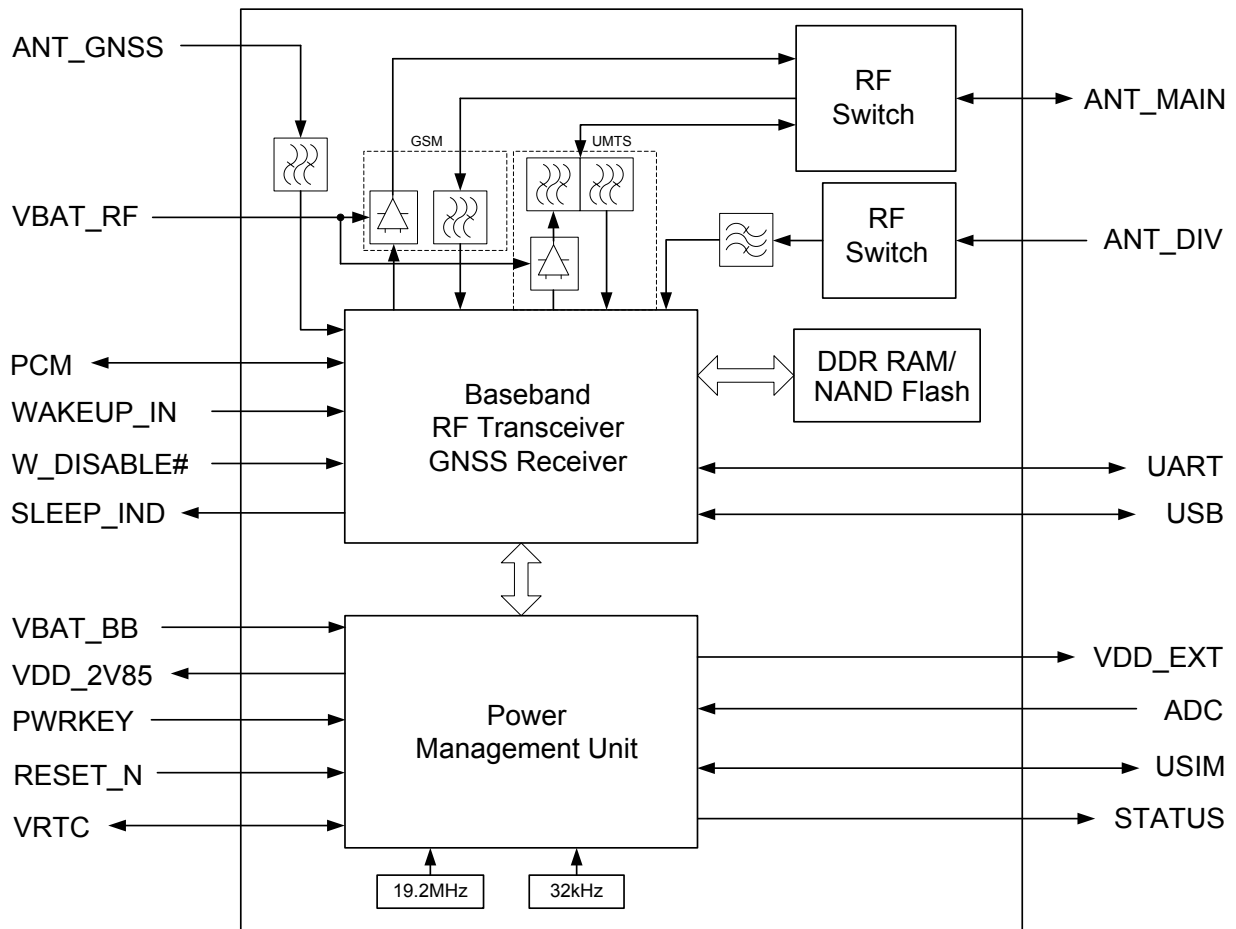

Figure 1: Functional Diagram

2.5. Evaluation Board

In order to help you to develop applications with UC20, Quectel supplies an evaluation board (EVB), RS-232 to USB cable, USB data cable, power adapter, earphone, antenna and other peripherals to control or test the module. For details, please refer to **document [2]**.

3 Application Interface

3.1. General Description

UC20 is equipped with a 72-pin 1.3mm pitch SMT pads plus 40-pin ground pads and reserved pads that connect to cellular application platform. Sub-interfaces included in these pads are described in detail in the following chapters:

- Power supply
- UART interface
- USIM interface
- USB interface
- PCM interface
- ADC interface
- Status indication

3.2. Pin Assignment

The following figure shows the pin assignment of the UC20 module.

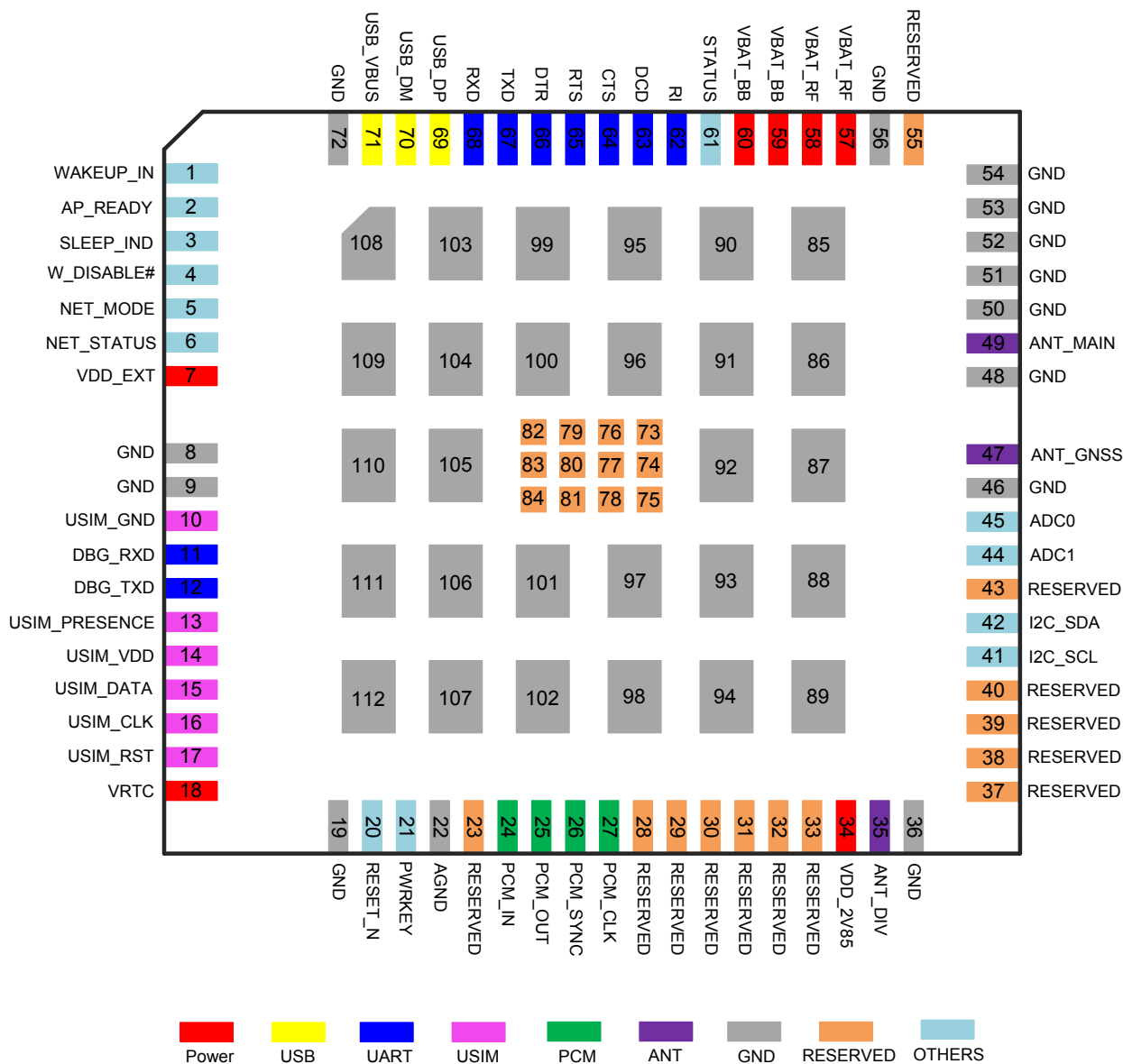

Figure 2: Pin Assignment (Top View)

NOTES

1. Keep all reserved pins and unused pins unconnected.
2. GND pads 85~112 should be connected to ground in the design, and RESERVED pads 73~84 should be unconnected.

3.3. Pin Description

The following tables show the UC20's pin definition.

Table 3: IO Parameters Definition

Type	Description
IO	Bidirectional input/output
DI	Digital input
DO	Digital output
PI	Power input
PO	Power output
AI	Analog input
AO	Analog output
OD	Open drain

Table 4: Pin Description

Power Supply					
Pin Name	Pin No.	I/O	Description	DC Characteristics	Comment
VBAT_BB	59,60	PI	Power supply for module baseband part.	Vmax = 4.3V Vmin = 3.4V Vnorm = 3.8V	It must be able to provide sufficient current up to 0.8A.
VBAT_RF	57,58	PI	Power supply for module RF part.	Vmax = 4.3V Vmin = 3.4V Vnorm = 3.8V	It must be able to provide sufficient current in a transmitting burst which typically rises to 2.0A.
VRTC	18	IO	Power supply for internal RTC circuit.	V _O max = 3.25V when VBAT ≥ 3.4V. V _I = 1.5V~3.25V at I _{IN} = 3uA when VBAT is not applied.	

VDD_EXT	7	PO	Provide 1.8V for external circuit.	V _{norm} = 1.8V I _{Omax} = 20mA	Power supply for external GPIO's pull up circuits.
VDD_2V85	34	PO	Provide 2.85V for external circuit.	V _{norm} = 2.85V I _{Omax} = 100mA	Power supply for external GNSS LNA, active antenna and other circuits.
GND	8,9,19,36, 46,48,50~ 54,56,72, 85~112		Ground.		

Turn On/Off

Pin Name	Pin No.	I/O	Description	DC Characteristics	Comment
PWRKEY	21	DI	Turn on/off the module.	R _{PU} ≈ 200kΩ V _{IHmax} = 2.1V V _{IHmin} = 1.3V V _{ILmax} = 500mV	Pull-up to 1.8V internally.
RESET_N	20	DI	Reset the module.	R _{PU} ≈ 200kΩ V _{IHmax} = 2.1V V _{IHmin} = 1.3V V _{ILmax} = 500mV	Pull-up to 1.8V internally. Active low.

Status Indication

Pin Name	Pin No.	I/O	Description	DC Characteristics	Comment
STATUS	61	OD	Indicate the module operating status.		Require external pull-up.
NET_MODE	5	DO	Indicate the module network registration mode.	V _{OHmin} = 1.35V V _{OLmax} = 0.45V	1.8V power domain.
NET_STATUS	6	DO	Indicate the module network activity status.	V _{OHmin} = 1.35V V _{OLmax} = 0.45V	1.8V power domain.
SLEEP_IND	3	DO	Indicate the sleep status.	V _{OHmin} = 1.35V V _{OLmax} = 0.45V	1.8V power domain.

USB Interface

Pin Name	Pin No.	I/O	Description	DC Characteristics	Comment
----------	---------	-----	-------------	--------------------	---------

USB_VBUS	71	PI	USB detection.	Vmax = 5.25V Vmin = 3.0V Vnorm = 5.0V	
USB_DP	69	IO	USB differential data bus.	Compliant with USB 2.0 standard specification.	Require differential impedance of 90Ω.
USB_DM	70	IO	USB differential data bus.	Compliant with USB 2.0 standard specification.	Require differential impedance of 90Ω.

USIM Interface

Pin Name	Pin No.	I/O	Description	DC Characteristics	Comment
USIM_GND	10		Specified ground for USIM card.		
USIM_VDD	14	PO	Power supply for USIM card.	For 1.8V USIM: Vmax = 1.98V Vmin = 1.62V For 3.0V USIM: Vmax = 3.3V Vmin = 2.7V I _O max = 50mA	Either 1.8V or 3V is supported by the module automatically.
USIM_DATA	15	IO	Data signal of USIM card.	For 1.8V USIM: V _{IL} max = 0.27V V _{IH} min = 1.26V V _{IH} max = 1.8V V _{OL} max = 0.27V V _{OH} min = 1.26V For 3.0V USIM: V _{IL} max = 0.45V V _{IH} min = 2.1V V _{IH} max = 3.0V V _{OL} max = 0.45V V _{OH} min = 2.1V	Pull-up to USIM_VDD with 15k resistor internally.
USIM_CLK	16	DO	Clock signal of USIM card.	For 1.8V USIM: V _{OL} max = 0.36V V _{OH} min = 1.26V For 3.0V USIM: V _{OL} max = 0.5V V _{OH} min = 2.1V	

USIM_RST	17	DO	Reset signal of USIM card.	For 1.8V USIM: $V_{OLmax} = 0.22V$ $V_{OHmin} = 1.44V$ For 3.0V USIM: $V_{OLmax} = 0.36V$ $V_{OHmin} = 2.4V$	
USIM_PRESENCE	13	DI	USIM card insertion detection.	$V_{ILmin} = -0.3V$ $V_{ILmax} = 0.6V$ $V_{IHmin} = 1.2V$ $V_{IHmax} = 2.0V$	1.8V power domain.

ADC Interface

Pin Name	Pin No.	I/O	Description	DC Characteristics	Comment
ADC0	45	AI	General purpose analog to digital converter.	Voltage range: 0.2V to 2.1V	
ADC1	44	AI	General purpose analog to digital converter.	Voltage range: 0.2V to 4.2V	

Main UART Interface

Pin Name	Pin No.	I/O	Description	DC Characteristics	Comment
RI	62	DO	Ring indicator.	$V_{OLmax} = 0.45V$ $V_{OHmin} = 1.35V$	1.8V power domain.
DCD	63	DO	Data carrier detection.	$V_{OLmax} = 0.45V$ $V_{OHmin} = 1.35V$	1.8V power domain.
CTS	64	DO	Clear to send.	$V_{OLmax} = 0.45V$ $V_{OHmin} = 1.35V$	1.8V power domain.
RTS	65	DI	Request to send.	$V_{ILmin} = -0.3V$ $V_{ILmax} = 0.6V$ $V_{IHmin} = 1.2V$ $V_{IHmax} = 2.0V$	1.8V power domain.
DTR	66	DI	Data terminal ready.	$V_{ILmin} = -0.3V$ $V_{ILmax} = 0.6V$ $V_{IHmin} = 1.2V$ $V_{IHmax} = 2.0V$	1.8V power domain. Pull-up by default.
TXD	67	DO	Transmit data.	$V_{OLmax} = 0.45V$ $V_{OHmin} = 1.35V$	1.8V power domain.

RXD	68	DI	Receive data.	$V_{ILmin} = -0.3V$ $V_{ILmax} = 0.6V$ $V_{IHmin} = 1.2V$ $V_{IHmax} = 2.0V$	1.8V power domain.
-----	----	----	---------------	---	--------------------

Debug UART Interface

Pin Name	Pin No.	I/O	Description	DC Characteristics	Comment
DBG_TXD	12	DO	Transmit data.	$V_{OLmax} = 0.45V$ $V_{OHmin} = 1.35V$	1.8V power domain.
DBG_RXD	11	DI	Receive data.	$V_{ILmin} = -0.3V$ $V_{ILmax} = 0.6V$ $V_{IHmin} = 1.2V$ $V_{IHmax} = 2.0V$	1.8V power domain.

RF Interface

Pin Name	Pin No.	I/O	Description	DC Characteristics	Comment
ANT_DIV	35	AI	Diversity antenna.	50Ω impedance	
ANT_MAIN	49	IO	Main antenna.	50Ω impedance	
ANT_GNSS	47	AI	GNSS antenna.	50Ω impedance	

PCM Interface

Pin Name	Pin No.	I/O	Description	DC Characteristics	Comment
PCM_IN	24	DI	PCM data input.	$V_{ILmin} = -0.3V$ $V_{ILmax} = 0.6V$ $V_{IHmin} = 1.2V$ $V_{IHmax} = 2.0V$	1.8V power domain.
PCM_OUT	25	DO	PCM data output.	$V_{OLmax} = 0.45V$ $V_{OHmin} = 1.35V$	1.8V power domain.
PCM_SYNC	26	IO	PCM data frame sync signal.	$V_{OLmax} = 0.45V$ $V_{OHmin} = 1.35V$ $V_{ILmin} = -0.3V$ $V_{ILmax} = 0.6V$ $V_{IHmin} = 1.2V$ $V_{IHmax} = 2.0V$	1.8V power domain. In master mode, it is an output signal. In slave mode, it is an input signal.
PCM_CLK	27	IO	PCM data bit clock.	$V_{OLmax} = 0.45V$ $V_{OHmin} = 1.35V$ $V_{ILmin} = -0.3V$ $V_{ILmax} = 0.6V$ $V_{IHmin} = 1.2V$ $V_{IHmax} = 2.0V$	1.8V power domain. In master mode, it's an output signal. In slave mode, it is an input signal.

AGND	22		Reserved for analog ground.	Ground.	If unused, connect this pin to ground.
I2C Interface					
Pin Name	Pin No.	I/O	Description	DC Characteristics	Comment
I2C_SCL	41	OD	I2C serial clock.		External pull-up resistor is required. 1.8V only.
I2C_SDA	42	OD	I2C serial data.		External pull-up resistor is required. 1.8V only.
Other Pins					
Pin Name	Pin No.	I/O	Description	DC Characteristics	Comment
WAKEUP_IN	1	DI	Sleep mode control.	V _{IL} min = -0.3V V _{IL} max = 0.6V V _{IH} min = 1.2V V _{IH} max = 2.0V	1.8V power domain. Pull-up by default. Low level wakes up the module.
W_DISABLE#	4	DI	Airplane mode control.	V _{IL} min = -0.3V V _{IL} max = 0.6V V _{IH} min = 1.2V V _{IH} max = 2.0V	1.8V power domain. Pull-up by default. In low level voltage, module can enter into airplane mode.
AP_READY	2	DI	Application processor sleep state detection.	V _{IL} min = -0.3V V _{IL} max = 0.6V V _{IH} min = 1.2V V _{IH} max = 2.0V	1.8V power domain.
RESERVED Pins					
Pin Name	Pin No.	I/O	Description	DC Characteristics	Comment
RESERVED	23,28~33,37~40,43,55,73~84		Reserved		Keep these pins unconnected.

3.4. Operating Modes

The table below briefly summarizes the various operating modes referred to in the following chapters.

Table 5: Overview of Operating Modes

Mode	Details
Normal Operation	UMTS Idle Software is active. The module has registered to the UMTS network and the module is ready to send and receive data.
	UMTS Talk/Data UMTS connection is ongoing. In this mode, the power consumption is decided by network setting (e.g. TPC pattern) and data transfer rate.
	HSPA Idle Software is active. The module has registered to the HSPA network and the module is ready to send and receive data.
	HSPA Data HSPA data transfer is ongoing. In this mode, the power consumption is decided by network setting (e.g. TPC pattern) and data transfer rate.
Minimum Functionality Mode	AT+CFUN command can set the module entering into a minimum functionality mode without removing the power supply. In this case, both RF function and USIM card will be invalid.
Airplane Mode	AT+CFUN command and W_DISABLE# pin can set the module entering into airplane mode. In this case, RF function will be invalid.
Sleep Mode	In this mode, the current consumption of the module will be reduced to the minimal level. During this mode, the module can still receive paging message, SMS and voice call from the network normally.
Power Down Mode	In this mode, the power management unit shuts down the power supply. Only the power supply for RTC remains. Software is not active. The serial interface is not accessible. Operating voltage (connected to VBAT_RF and VBAT_BB) remains applied.

3.5. Power Saving

3.5.1. Sleep Mode

UC20 is able to reduce its current consumption to a minimum value during the sleep mode. The following section describes UC20's power saving procedure.

3.5.1.1. UART Application

If application processor communicates with module via UART interface, the following preconditions can let the module enter into the sleep mode.

- Execute AT command **AT+QSCLK=1** to enable the sleep mode.
- Drive DTR to high level.

The following figure shows the connection between the module and application processor.

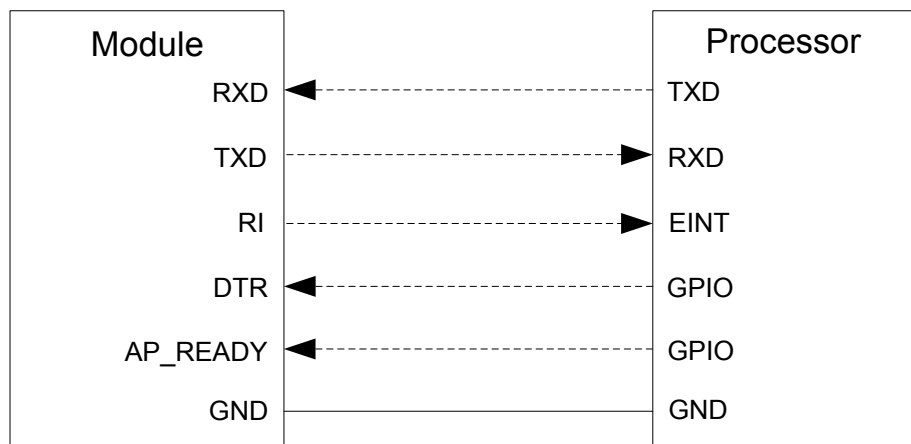

Figure 3: UART Sleep Application

The RI of module is used to wake up the processor, and AP_READY will detect the sleep state of processor (can be configured to high level or low level detection). You should pay attention to the level match shown in dotted line between module and processor.

Drive DTR to low level will wake up the module.

3.5.1.2. USB Application with Suspend Function

If application processor communicates with module via USB interface, and processor supports USB suspend function, the following preconditions can let the module enter into the sleep mode.

- Execute AT command **AT+QSCLK=1** to enable the sleep mode.
- The processor's USB bus which is connected with the module USB interface enters into suspended state.

The following figure shows the connection between the module and processor.

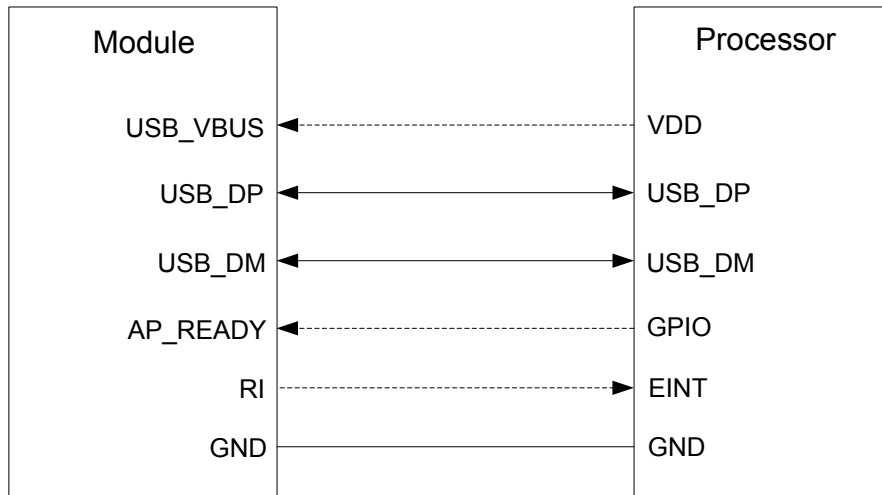

Figure 4: USB Application with Suspend Function

When the processor's USB bus returns to resume state, the module will be woken up.

3.5.1.3. USB Application without Suspend Function

If application processor communicates with module via USB interface, and processor does not support USB suspend function, you should disconnect USB_VBUS with additional control circuit to let the module enter into sleep mode.

- Execute AT command **AT+QSCLK=1** to enable the sleep mode.
- Disconnect USB_VBUS.

The following figure shows the connection between the module and application processor.

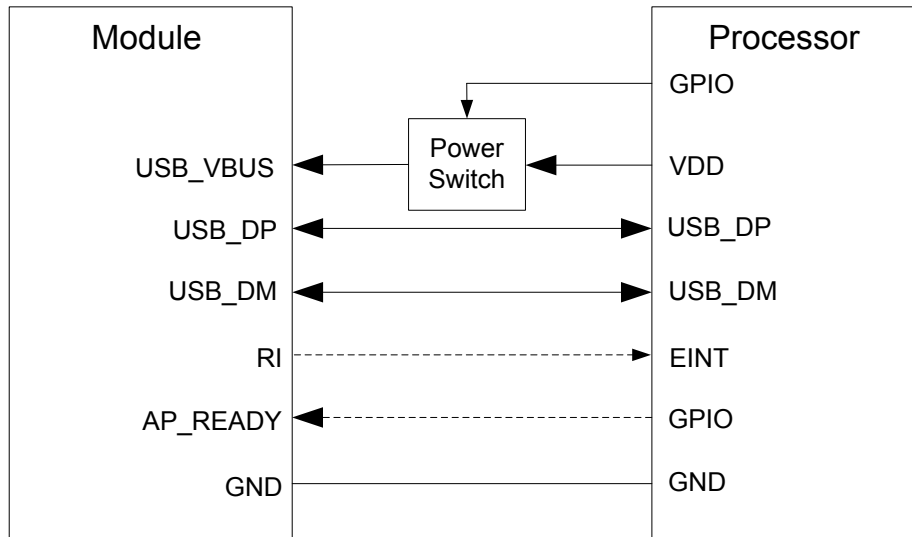

Figure 5: USB Sleep Application without Suspend Function

Supply power to USB_VBUS will wake up the module.

In sleep mode, module can still receive paging, voice call and SMS from network, but the UART port is not accessible. When the module enters into the sleep mode, the SLEEP_IND will output a high logic level.

3.5.2. Airplane Mode

When module gets into the airplane mode, the RF function does not work, and all AT commands correlative with RF function will be not accessible. This mode can be set with the following way.

Hardware:

The W_DISABLE# pin is pulled up by default, drive it to low level will let the module get into airplane mode.

Software:

Command **AT+CFUN** provides the choice of the functionality level <fun>=0, 1, 4.

AT+CFUN=0: Minimum functionality mode, both USIM and RF function are disabled.

AT+CFUN=1: Full functionality mode (by default).

AT+CFUN=4: Airplane mode. RF function is disabled.

NOTES

1. The W_DISABLE# control function is disabled in firmware by default. It can be enabled by AT command **AT+QCFG="airplanecontrol"**. Refer to *document [1]*.
2. When the module is in sleep mode, the W_DISABLE# control is invalid. Please be sure to wake the

- module up first.
- GNSS function is still available when RF function is disabled.

3.6. Power Supply

3.6.1. Power Supply Pins

UC20 provides four VBAT pins dedicated to connect with the external power supply. There are two separate voltage domains for VBAT.

- VBAT_RF with two pads for module RF part.
- VBAT_BB with two pads for module baseband part.

The following table shows the VBAT pins and ground pins.

Table 6: VBAT and GND Pins

Pin Name	Pin No.	Description	Min.	Typ.	Max.	Unit
VBAT_RF	57,58	Power supply for module RF part.	3.4	3.8	4.3	V
VBAT_BB	59,60	Power supply for module baseband part.	3.4	3.8	4.3	V
GND	8,9,19,36,46, 48,50~54,56, 72, 85~112	Ground.	-	0	-	V

3.6.2. Decrease Voltage Drop

The power supply range of the module is 3.4V ~ 4.3V. Because of the voltage drop during the transmitting time, a bypass capacitor of about 100μF with low ESR should be used. Multi-layer ceramic chip (MLCC) capacitor can provide the best combination of low ESR. Three ceramic capacitors (100nF, 33pF, 10pF) are recommended to be applied to the VBAT pins. The capacitors should be placed close to the UC20's VBAT pins. The following figure shows star structure of the power supply.

The main power supply from an external application has to be a single voltage source and has to be expanded to two sub paths with star structure. In addition, in order to get a stable power source, it is suggested to use a zener diode of which reverse zener voltage is 5.1V and dissipation power is more than 0.5W.

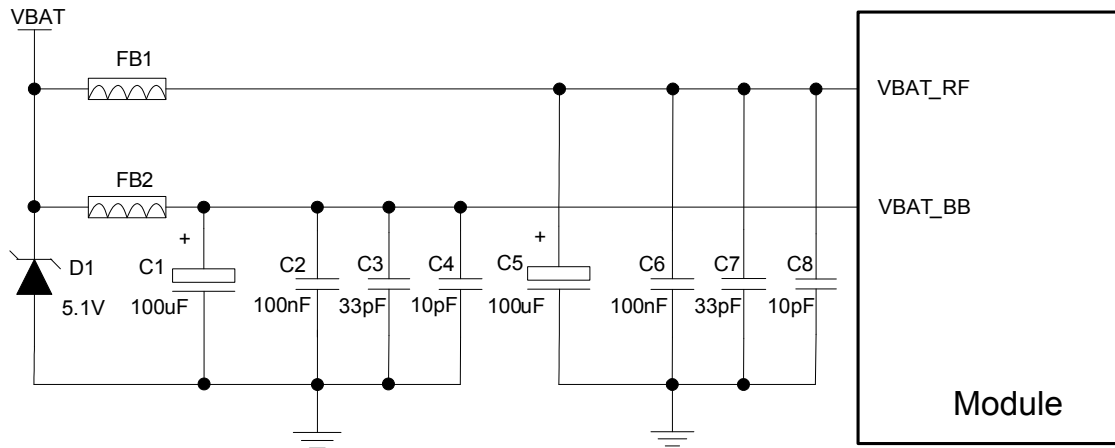

Figure 6: Star Structure of the Power Supply

Please pay special attention to the power supply design for applications. Make sure the input voltage will never drop below 3.4V. If the voltage drops below 3.4V, the module will turn off automatically. The PCB traces from the VBAT pins to the power source must be wide enough to ensure that there isn't too much voltage drop occurs in the transmitting procedure. The width of VBAT_BB trace should be no less than 1mm, and the width of VBAT_RF trace should be no less than 2mm, and the principle of the VBAT trace is the longer, the wider.

3.6.3. Reference Design for Power Supply

The power design for the module is very important, since the performance of power supply for the module largely depends on the power source. The power supply is capable of providing the sufficient current up to 2A at least. If the voltage drop between the input and output is not too high, it is suggested to use a LDO to supply power for module. If there is a big voltage difference between the input source and the desired output (VBAT), a buck converter is preferred to be used as a power supply.

The following figure shows a reference design for +5V input power source. The designed output for the power supply is 3.88V and the maximum load current is 3A.

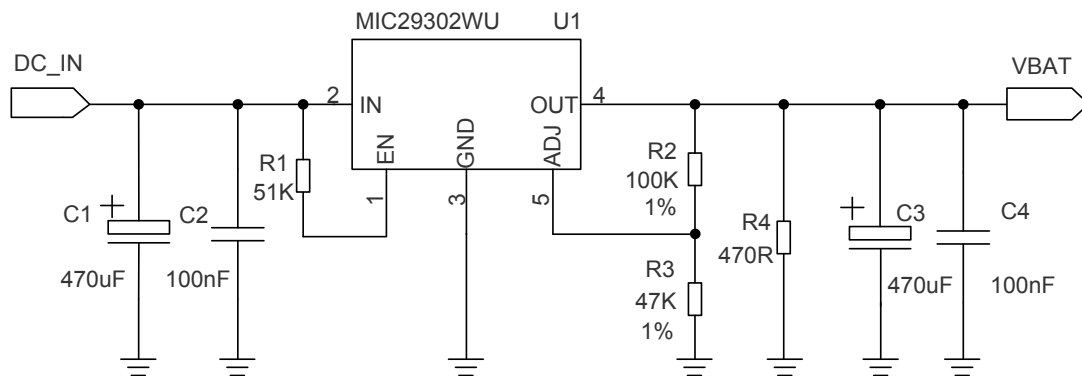

Figure 7: Reference Circuit of Power Supply

3.6.4. Monitor the Power Supply

You can use the **AT+CBC** command to monitor the VBAT_BB voltage value. For more details, please refer to *document [1]*.

3.7. Turn on and off Scenarios

3.7.1. Turn on Module Using the PWRKEY

The following table shows the pin definition of PWRKEY.

Table 7: PWRKEY Pin Description

Pin Name	Pin No.	Description	DC Characteristics	Comment
PWRKEY	21	Turn on/off the module.	$V_{IHmax} = 2.1V$ $V_{IHmin} = 1.3V$ $V_{ILmax} = 500mV$	Pull-up to 1.8V internally with 200kΩ resistor.

When UC20 is in power down mode, it can be turned on to normal mode by driving the PWRKEY pin to a low level at least 100ms. It is recommended to use an open drain/collector driver to control the PWRKEY. You can monitor the level of the STATUS pin to judge whether the module is turned on or not. After STATUS pin (require external pull-up) outputting a low level, PWRKEY pin can be released. A simple reference circuit is illustrated in the following figure.

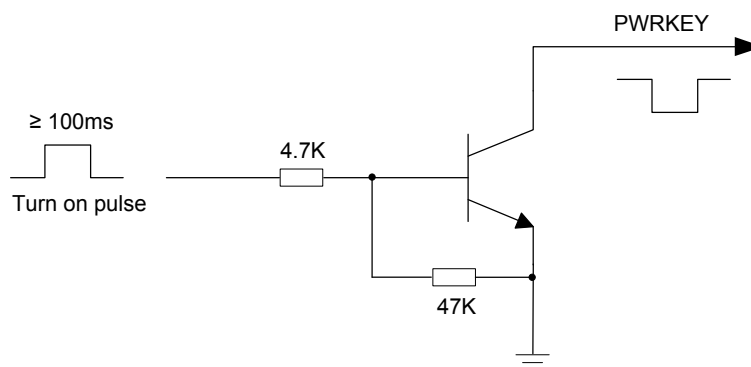

Figure 8: Turn on the Module Using Driving Circuit

The other way to control the PWRKEY is using a button directly. A TVS component is indispensable to be placed nearby the button for ESD protection. When pressing the key, electrostatic strike may generate from finger. A reference circuit is showed in the following figure.

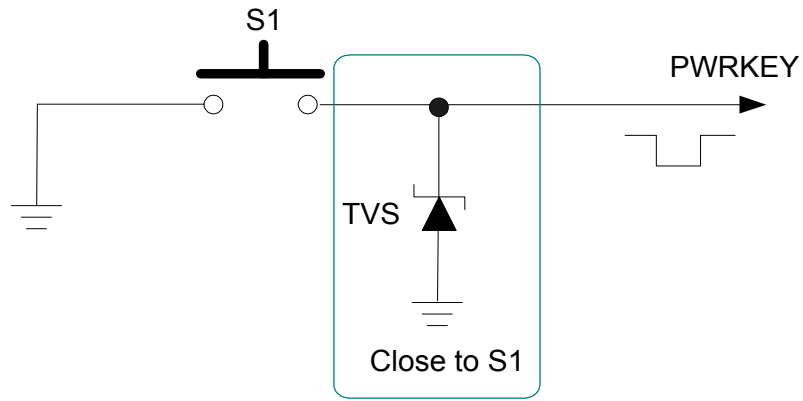

Figure 9: Turn on the Module Using Keystroke

The turn on scenarios is illustrated as the following figure.

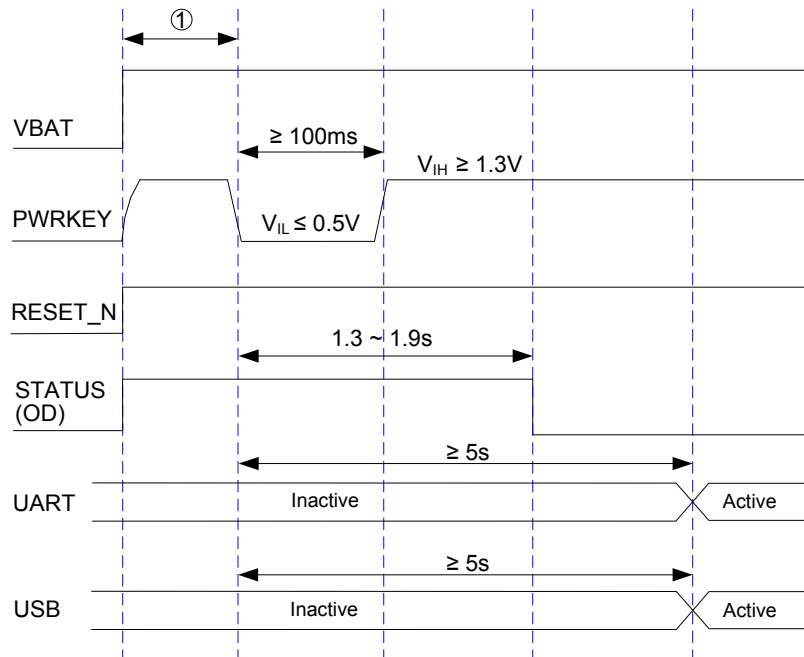

Figure 10: Timing of Turning on Module

NOTES

Make sure that VBAT is stable before pulling down PWRKEY pin. The time between them is recommended 30ms.

3.7.2. Turn off Module

The following procedures can be used to turn off the module:

- Normal power down procedure: Turn off the module using the PWRKEY pin.
- Normal power down procedure: Turn off the module using command **AT+QPOWD**.
- Automatic shutdown: Turn off the module automatically if under-voltage or over-voltage is detected.

3.7.2.1. Turn off Module Using the PWRKEY Pin

Driving the PWRKEY to a low level voltage at least 0.6s, the module will execute power-down procedure after PWRKEY is released. The power-down scenario is illustrated as the following figure.

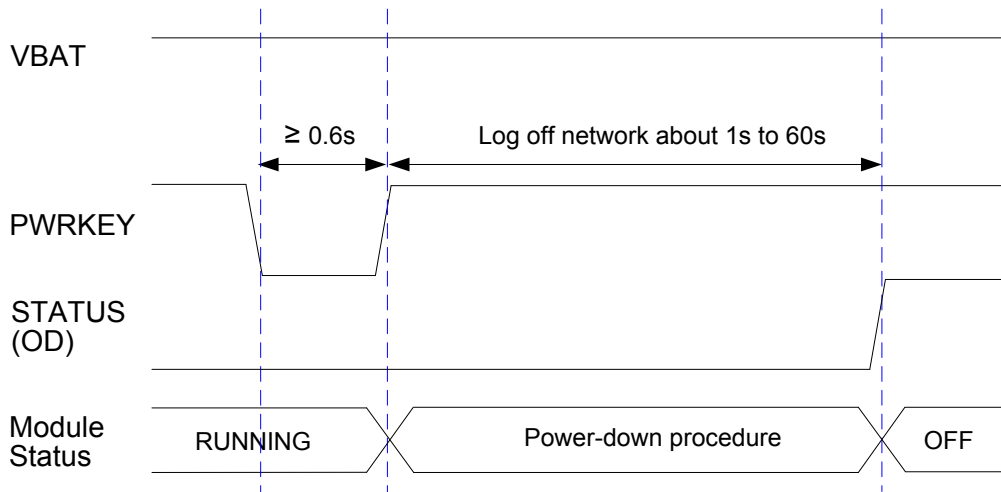

Figure 11: Timing of Turning off Module

During power-down procedure, module will send out URC “NORMAL POWER DOWN” via URC port first, then log off network and save important data. After logging off, module sends out “POWERED DOWN” and shut down the internal power supply. The power on VBAT pins is not allowed to turn off before the URC “POWERED DOWN” is output to avoid data loss. If logging off is not done within 60s, module will shut down internal power supply forcibly.

After that moment, the module enters the power down mode, no other AT commands can be executed and only the RTC is still active. The power down mode can also be indicated by the STATUS pin.

3.7.2.2. Turn off Module Using AT Command

It is also a safe way to use AT command **AT+QPOWD** to turn off the module, which is similar to turning off the module via PWRKEY Pin

Please refer to **document [1]** for details about the AT command of **AT+QPOWD**.

3.7.2.3. Automatic Shutdown

The module will constantly monitor the voltage applied on the VBAT, if the voltage $\leq 3.5V$, the following URC will be presented:

+QIND: “vbatt”,-1

If the voltage $\geq 4.21V$, the following URC will be presented:

+QIND: “vbatt”,1

The uncritical voltage is 3.4V to 4.3V, If the voltage > 4.3V or < 3.4V the module would automatically shut down itself.

If the voltage < 3.4V, the following URC will be presented:

+QIND: "vbatt",-2

If the voltage > 4.3V, the following URC will be presented:

+QIND: "vbatt",2

NOTE

The value of voltage threshold can be revised by command **AT+QCFG="vbatt"**, refer *to document [1]* for details.

3.8. Reset the Module

The RESET_N can be used to reset the module.

Table 8: RESET_N Pin Description

Pin Name	Pin No.	Description	DC Characteristics	Comment
RESET_N	20	Reset the module.	$V_{IHmax} = 2.1V$ $V_{IHmin} = 1.3V$ $V_{ILmax} = 500mV$	Pull-up to 1.8V internally with 200kΩ resistor. Active low.

You can reset the module by driving the RESET_N to a low level voltage for more than 150ms and then releasing.

The recommended circuit is similar to the PWRKEY control circuit. You can use open drain/collector driver or button to control the RESET_N.

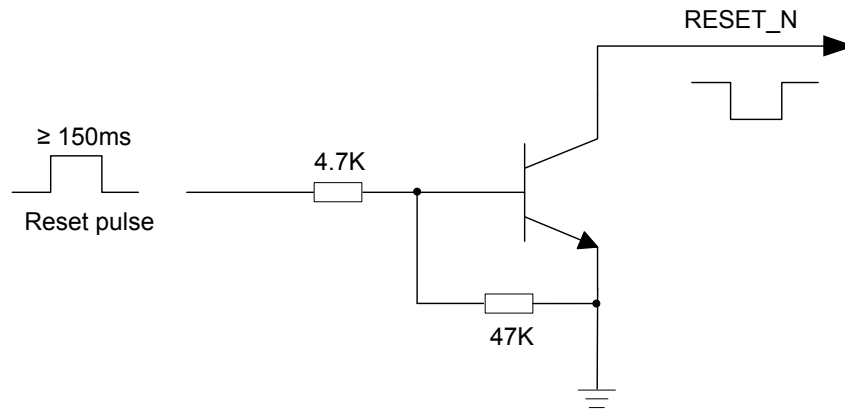

Figure 12: Reference Circuit of RESET_N by Using Driving Circuit

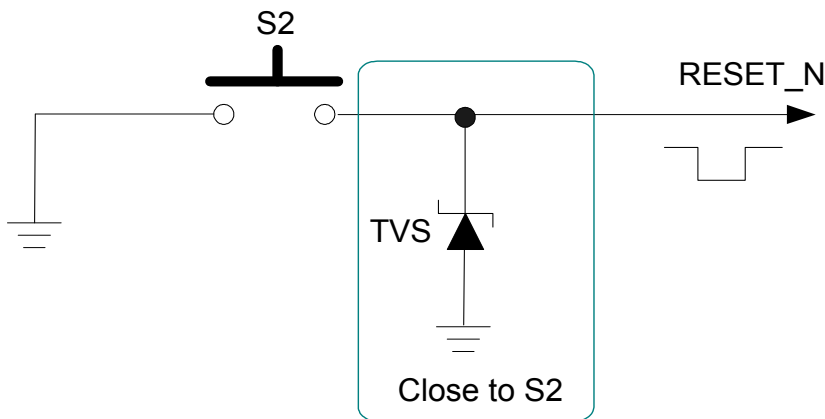

Figure 13: Reference Circuit of RESET_N by Using Button

The reset scenario is illustrated as the following figure.

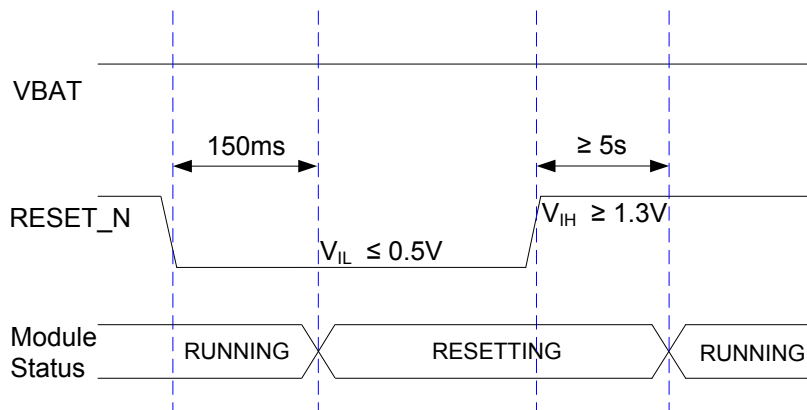

Figure 14: Timing of Resetting Module

NOTE

Use the RESET_N only when turning off the module by the command **AT+QPOWD** and the PWRKEY pin failed.

3.9. RTC Backup

The RTC (Real Time Clock) can be powered by an external power source through the pin VRTC when the module is powered down and there is no power supply for the VBAT. It is also available to charge the battery on the VRTC when module is turned on. You can choose rechargeable battery, capacitor or non-rechargeable battery depending on different applications.

The following figures show the various sample circuits for VRTC backup.

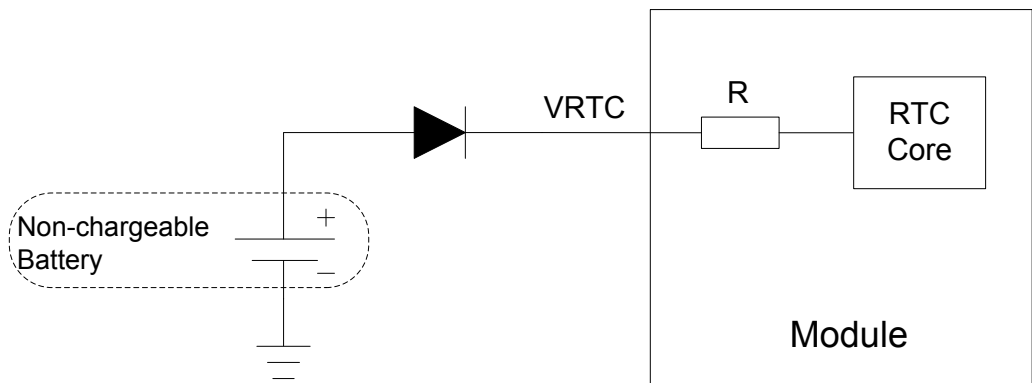

Figure 15: RTC Supply from Non-chargeable Battery

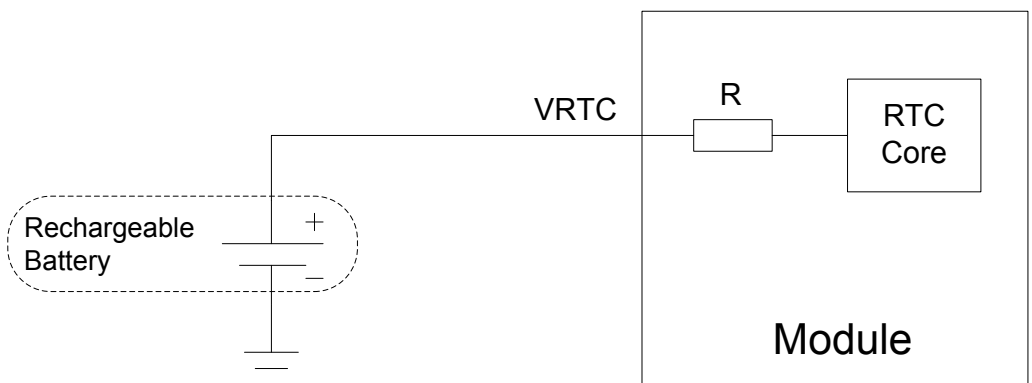

Figure 16: RTC Supply from Rechargeable Battery

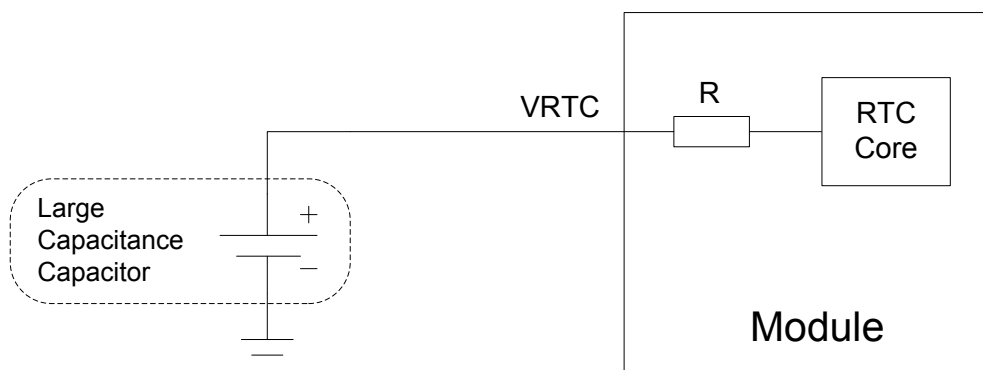

Figure 17: RTC Supply from Capacitor

3.10. UART Interface

The module provides two UART interfaces: main UART interface and debug UART interface. The following shows the different features.

- Main UART interface supports 9600, 19200, 38400, 57600, 115200, 230400, 460800, 921600bps baud rate, the default is 115200bps, while autobauding is not supported. This interface can be used for data transmission, AT communication or firmware upgrade.
- Debug UART interface supports 115200bps. It can be used for GNSS NMEA sentences output.

NOTE

USB interface supports software debug and firmware upgrade by default.

The module is designed as the DCE (Data Communication Equipment), following the traditional DCE-DTE (Data Terminal Equipment) connection. The following tables show the pin definition of these two UART interfaces.

Table 9: Pin Definition of the Main UART Interface

Pin Name	Pin No.	I/O	Description	Comment
RI	62	DO	Ring indicator.	1.8V power domain.
DCD	63	DO	Data carrier detection.	1.8V power domain.
CTS	64	DO	Clear to send.	1.8V power domain.
RTS	65	DI	Request to send.	1.8V power domain.

DTR	66	DI	Data terminal ready.	1.8V power domain.
TXD	67	DO	Transmit data.	1.8V power domain.
RXD	68	DI	Receive data.	1.8V power domain.

Table 10: Pin Definition of the Debug UART Interface

Pin Name	Pin No.	I/O	Description	Comment
DBG_TXD	12	DO	Transmit data.	1.8V power domain.
DBG_RXD	11	DI	Receive data.	1.8V power domain.

The logic levels are described in the following table.

Table 11: Logic Levels of Digital I/O

Parameter	Min	Max	Unit
V_{IL}	-0.3	0.6	V
V_{IH}	1.2	2.0	V
V_{OL}	0	0.45	V
V_{OH}	1.35	1.8	V

UC20 provides 1.8V UART interface. A level translator should be used if your application is equipped with a 3.3V UART interface. A level translator TXB0108PWR provided by **Texas Instruments** is recommended. The following figure shows the reference design of the TXB0108PWR.

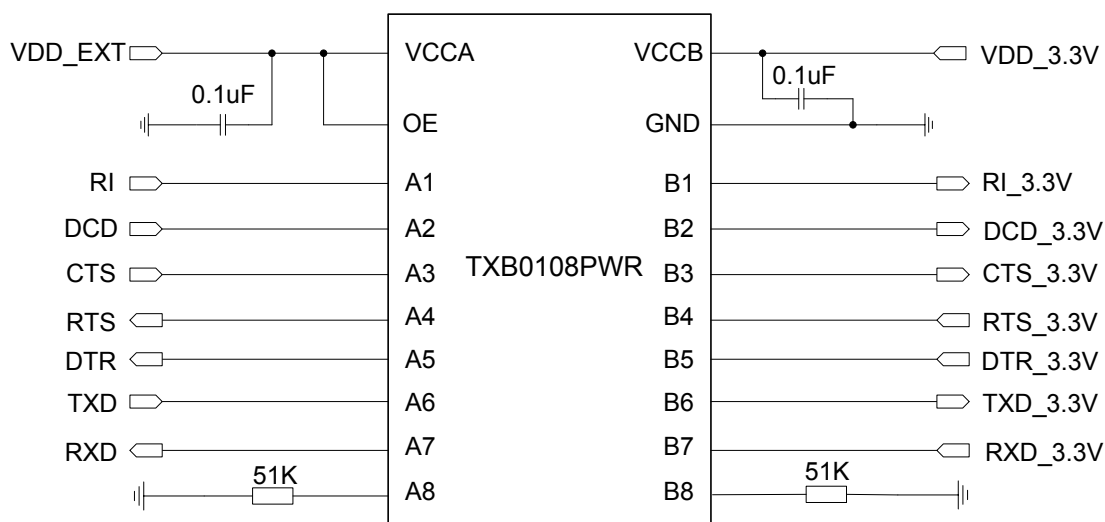

Figure 18: Reference Circuit with Translator Chip

Please visit <http://www.ti.com> for more information.

Another example with transistor translation circuit is shown as below. The construction of dotted line can refer to the construction of solid line. Please pay attention to direction of connection. Input dotted line of module should refer to input solid line of the module. Output dotted line of module should refer to output solid line of the module.

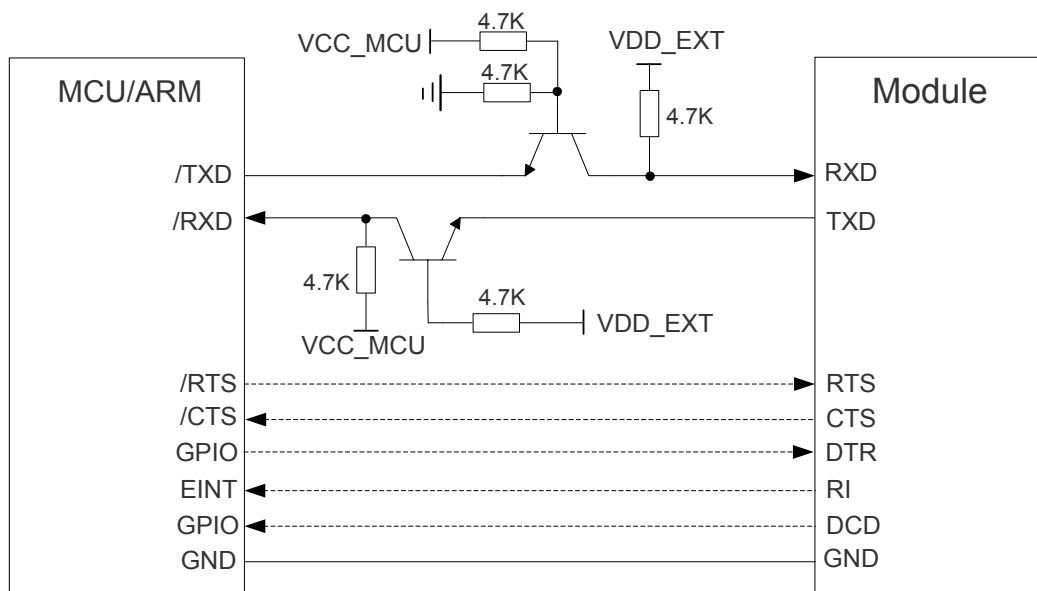

Figure 19: Reference Circuit with Transistor Circuit

The following figure is an example of connection between UC20 and PC. A voltage level translator and a RS-232 level translator chip must be inserted between module and PC, since these two UART interfaces do not support the RS-232 level, while support the 1.8V CMOS level only.

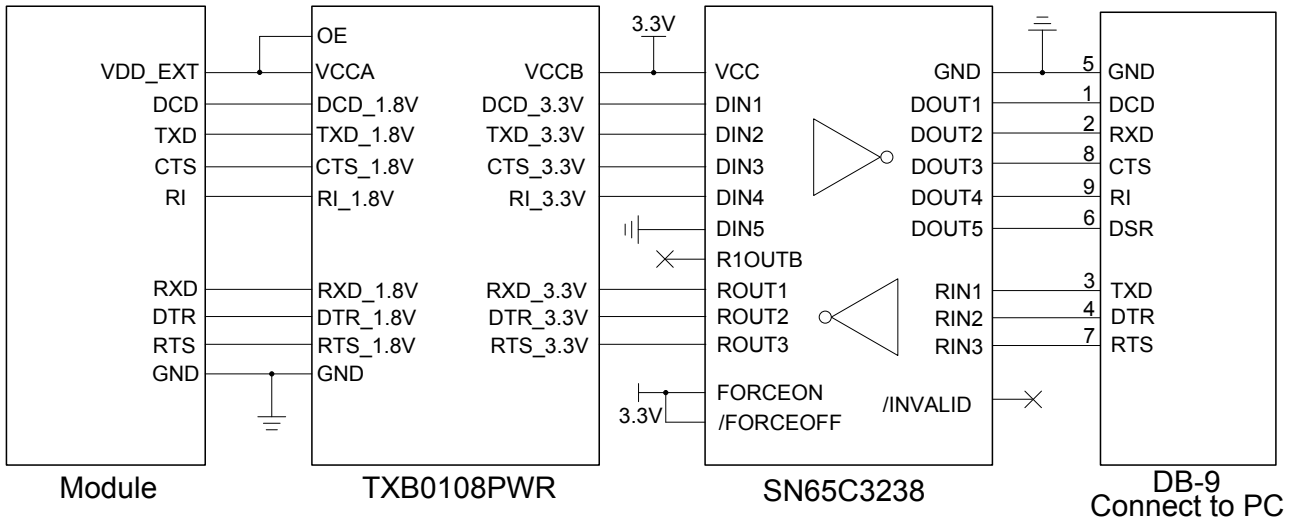

Figure 20: RS232 Level Match Circuit

The following figure shows the reference circuit of debug UART interface with logic level translator. TXB0102DCU provided by **Texas Instruments** is recommended.

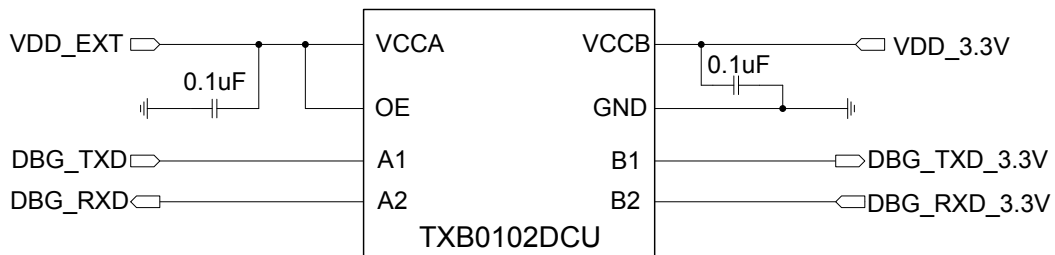

Figure 21: Reference Circuit of Debug UART with Level Translator

Please visit <http://www.ti.com> for more information.

NOTES

1. The module disables the hardware flow control by default. When hardware flow control is required, RTS and CTS should be connected to the host. AT command **AT+IFC=2,2** is used to enable hardware flow control. AT command **AT+IFC=0,0** is used to disable the hardware flow control. For more details, please refer to **document [1]**.
2. Rising on DTR will let the module exit from the data mode by default. It can be disabled by AT commands. Refer to **document [1]** about the command **AT&D** and **AT&V** for details.
3. DCD is used as data mode indication. Refer to **document [1]** about the command **AT&C** and **AT&V** for details.

3.11. USIM Card Interface

3.11.1. USIM Card Application

The USIM card interface circuitry meets ETSI and IMT-2000 SIM interface requirements. Both 1.8V and 3.0V USIM cards are supported.

Table 12: Pin Definition of the USIM Interface

Pin Name	Pin No.	I/O	Description	Comment
USIM_VDD	14	PO	Power supply for USIM card.	Either 1.8V or 3.0V is supported by the module automatically.
USIM_DATA	15	IO	Data signal of USIM card.	Pull-up to USIM_VDD with 15k resistor internally.
USIM_CLK	16	DO	Clock signal of USIM card.	
USIM_RST	17	DO	Reset signal of USIM card.	
USIM_PRES ENCE	13	DI	USIM card insertion detection.	1.8V power domain.
USIM_GND	10		Specified ground for USIM card.	

The following figure shows the reference design of the 8-pin USIM card.

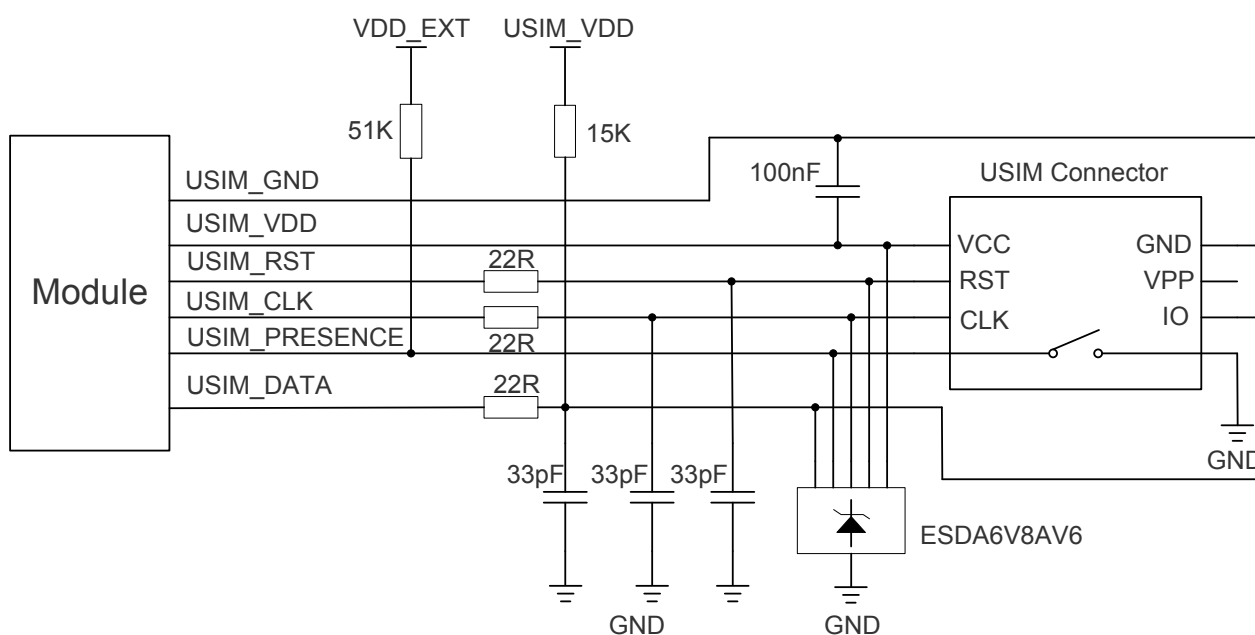

Figure 22: Reference Circuit of the 8 Pin USIM Card

NOTE

Some AT commands are invalid when USIM card is not applied.

UC20 supports USIM card hot-plugging via the USIM_PRESENCE pin. For details, refer to **document [1]** about the command **AT+QSIMDET**. If you do not need the USIM card detection function, keep USIM_PRESENCE unconnected. The reference circuit for using a 6-pin USIM card connector is illustrated as the following figure.

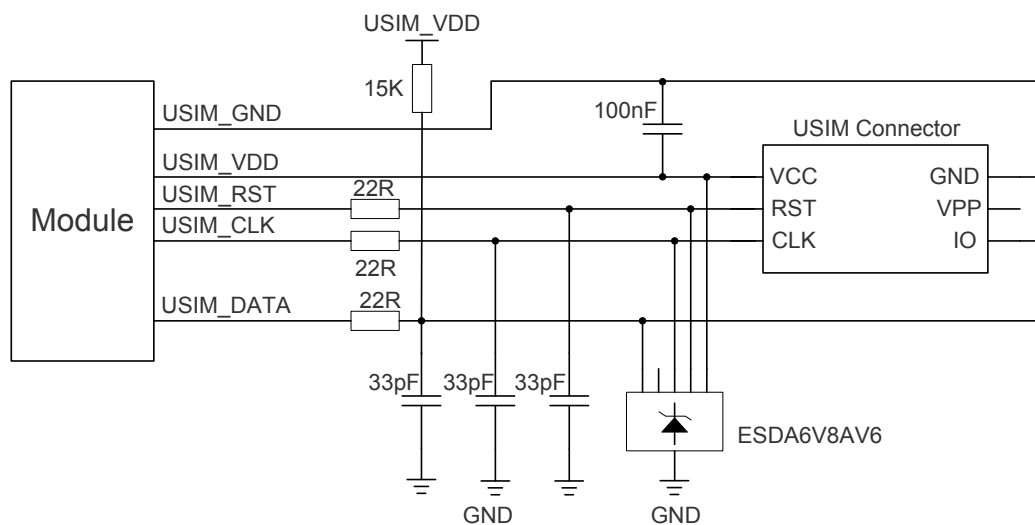

Figure 23: Reference Circuit of the 6 Pin USIM Card

In order to enhance the reliability and availability of the USIM card in your application, please follow the following criterion in the USIM circuit design:

- Keep layout of USIM card as close as possible to the module. Assure the length of the trace is less than 200mm.
- Keep USIM card signal away from RF and VBAT alignment.
- Assure the ground between module and USIM connector short and wide. Keep the width of ground and USIM_VDD no less than 0.5mm to maintain the same electric potential. The decouple capacitor of USIM_VDD should be less than 1uF and must be near to USIM connector.
- To avoid cross-talk between USIM_DATA and USIM_CLK, keep them away with each other and shield them with surrounded ground.
- In order to offer good ESD protection, it is recommended to add TVS such as WILL (<http://www.willsemi.com>) ESDA6V8AV6. The 22Ω resistors should be added in series between the module and the USIM card so as to suppress the EMI spurious transmission and enhance the ESD protection.
- The pull-up resistor on USIM_DATA line can improve anti-jamming capability when long layout trace and sensitive occasion is applied.

3.11.2. Design Considerations for USIM Connector

For 8-pin USIM connector, it is recommended to use Molex 91228. Please visit <http://www.molex.com> for more information.

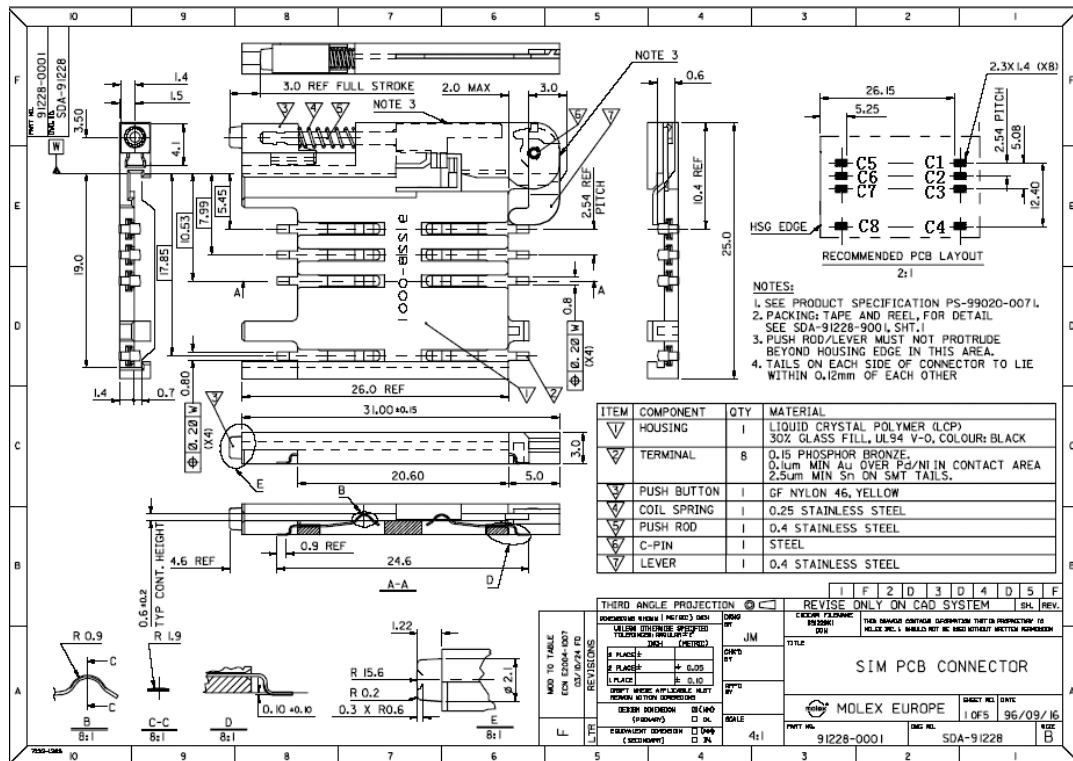

Figure 24: Molex 91228 USIM Connector

Table 13: Pin Description of Molex USIM Connector

Name	Pin	Function
VDD	C1	USIM card power supply.
RST	C2	USIM card reset.
CLK	C3	USIM card clock.
/	C4	Not defined.
GND	C5	Ground.
VPP	C6	Not connected.
DATA I/O	C7	USIM card data.
/	C8	Pull-down GND with external circuit. When the tray is present, C4 is connected to C8.

For 6-pin USIM connector, it is recommended to use Amphenol C707 10M006 512 2. Please visit <http://www.amphenol.com> for more information.

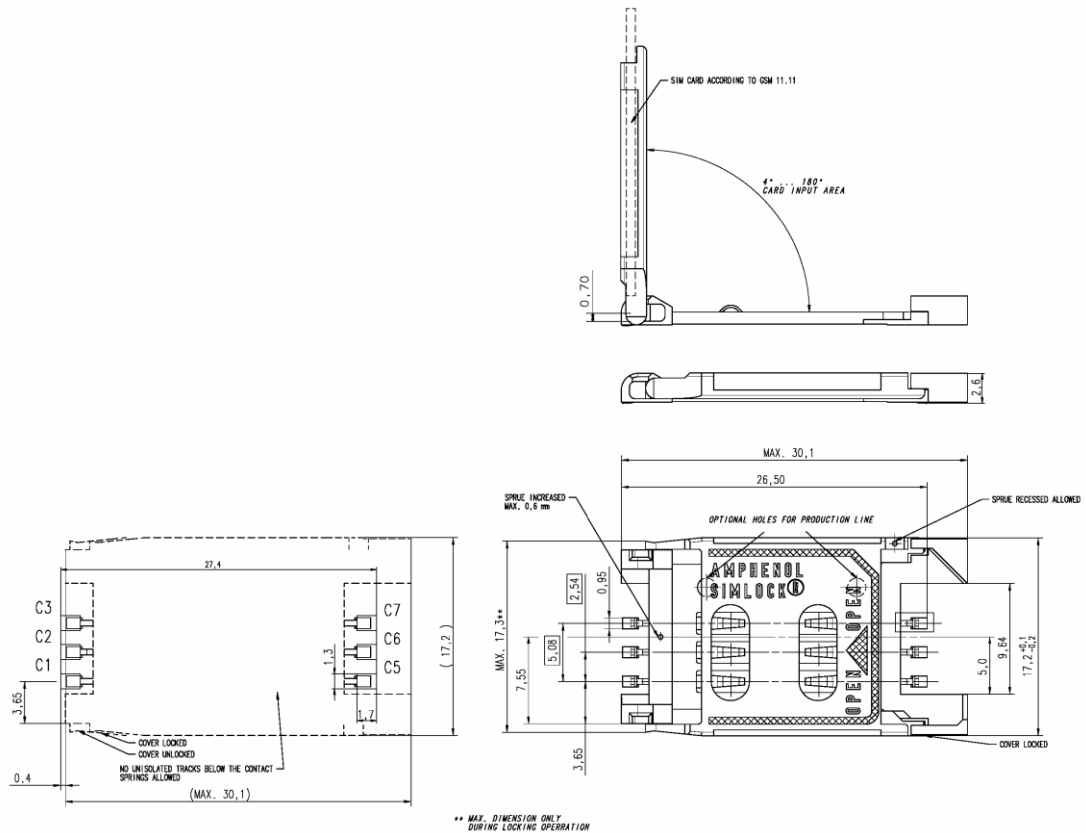

Figure 25: Amphenol C707 10M006 512 2 USIM Card Connector

Table 14: Pin Description of Amphenol USIM Connector

Name	Pin	Function
VDD	C1	USIM card power supply.
RST	C2	USIM card reset.
CLK	C3	USIM card clock.
GND	C5	Ground.
VPP	C6	Not connected.
DATA I/O	C7	USIM card data.

3.12. USB Interface

UC20 contains one integrated Universal Serial Bus (USB) transceiver which complies with the USB 2.0 specification and supports high speed (480 Mbps), full speed (12 Mbps) and low speed (1.5 Mbps) mode. The USB interface is primarily used for AT command, data transmission, GNSS NMEA sentences output, software debug and firmware upgrade. The following table shows the pin definition of USB interface.

Table 15: USB Pin Description

Pin Name	Pin No.	I/O	Description	Comment
USB_DP	69	IO	USB differential data bus (positive).	Require differential impedance of 90Ω.
USB_DM	70	IO	USB differential data bus (minus).	Require differential impedance of 90Ω.
USB_VBUS	71	PI	Used for detecting the USB interface connected.	3.0~5.25V. Typical 5.0V.
GND	72		Ground.	

More details about the USB 2.0 specifications, please visit <http://www.usb.org/home>.

The following figure shows the reference circuit of USB interface.

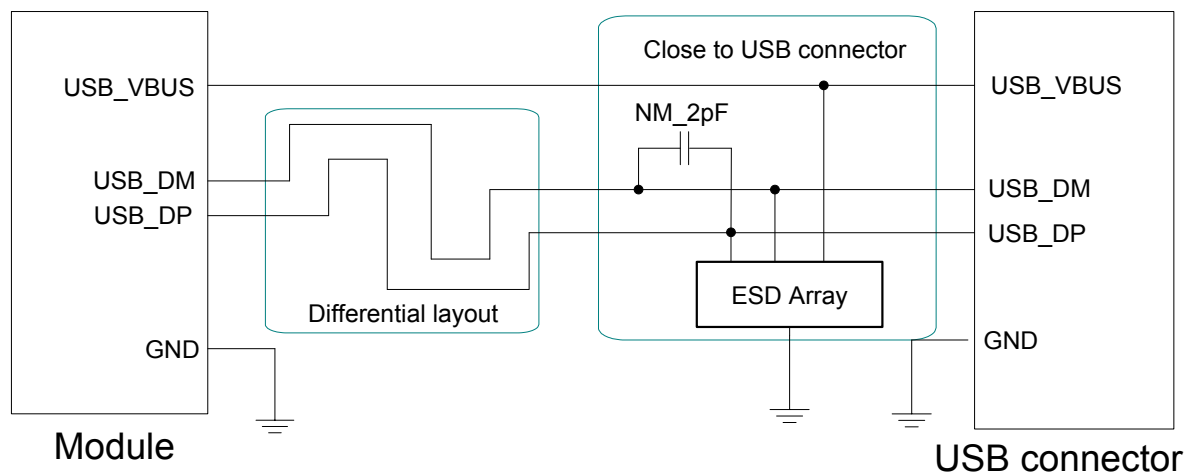

Figure 26: Reference Circuit of USB Application

In order to ensure the USB interface design corresponding with the USB 2.0 specification, please comply with the following principles.

- It is important to route the USB signal traces as differential pairs with total grounding. The impedance of USB differential trace is 90ohm.
- Do not route signal traces under crystals, oscillators, magnetic devices and RF signal traces. It is important to route the USB differential traces in inner-layer with ground shielding not only upper and lower layer but also right and left side.
- Pay attention to the influence of junction capacitance of ESD component on USB data lines. Typically, the capacitance value should be less than 2pF (e.g.ESD9L5.0ST5G).
- Keep the ESD components as closer to the USB connector as possible.

NOTE

UC20 module can only be used as a slave device.

The USB interface is recommended to be reserved for firmware upgrade in your design. The following figure shows the recommended test points.

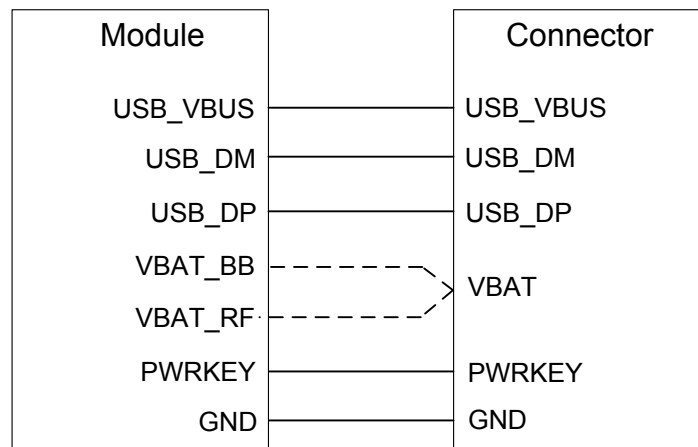

Figure 27: Test Points of Firmware Upgrade

3.13. PCM and I2C Interface

UC20 provides one Pulse Code Modulation (PCM) digital interface for audio design, which supports the following modes:

- Primary mode (short sync, works as both master and slave)
- Auxiliary mode (long sync, works as master only)

In primary mode, the data is sampled on the falling edge of the PCM_CLK and transmitted on the rising edge; the PCM_SYNC falling edge represents the MSB. In this mode, PCM_CLK supports 128, 256, 512, 1024, 2048 and 4096kHz for different speech codec.

In auxiliary mode, the data is sampled on the falling edge of the PCM_CLK and transmitted on the rising edge; while the PCM_SYNC rising edge represents the MSB. In this mode, PCM interface operates with a 128kHz PCM_CLK and an 8kHz, 50% duty cycle PCM_SYNC only.

UC20 supports 8-bit A-law and μ -law, and also 16-bit linear data formats. The following figures show the primary mode's timing relationship with 8kHz PCM_SYNC and 2048kHz PCM_CLK and auxiliary mode's timing relationship with 8kHz PCM_SYNC and 128kHz PCM_CLK.

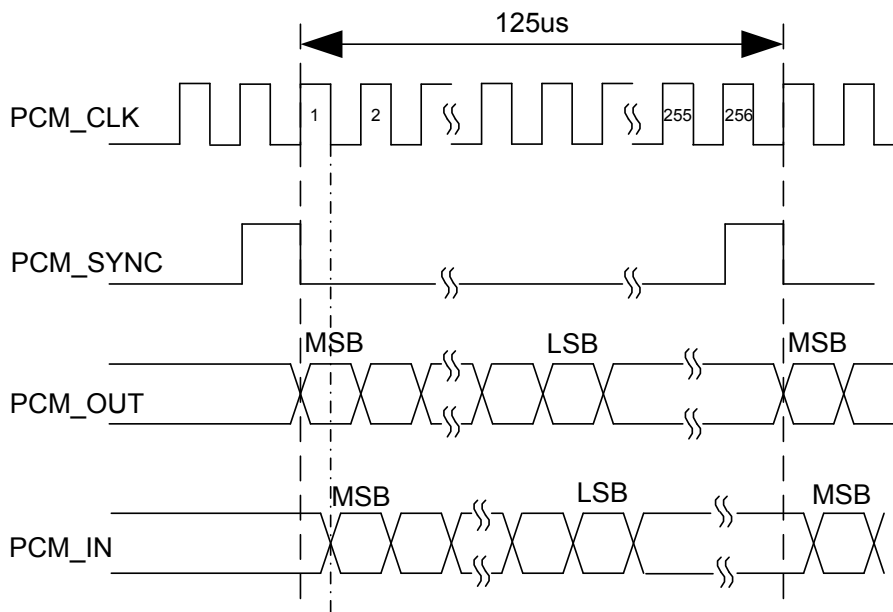

Figure 28: Primary Mode Timing

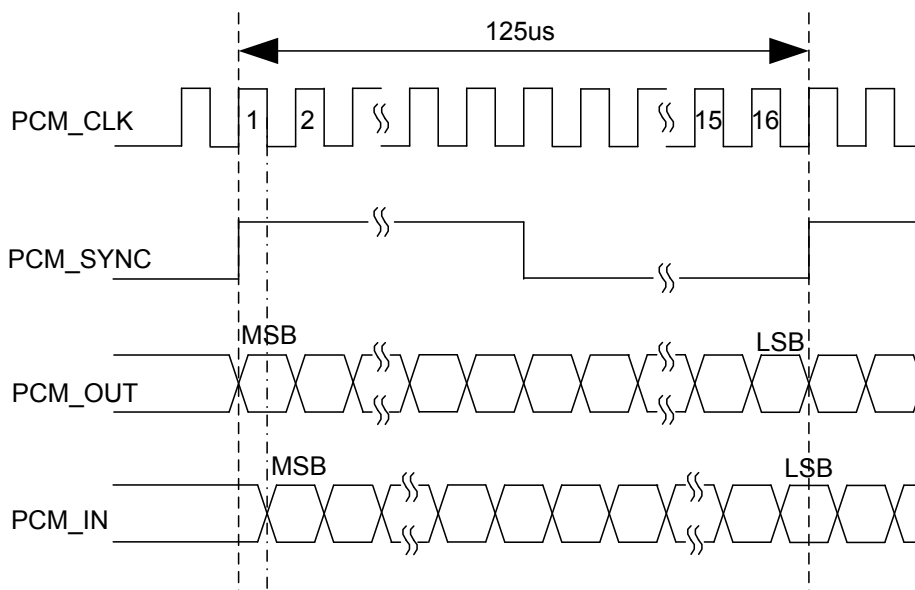

Figure 29: Auxiliary Mode Timing

The following table shows the pin definition of PCM and I2C interface which can be applied on audio codec design.

Table 16: Pin Definition of PCM and I2C Interface

Pin Name	Pin No.	I/O	Description	Comment
PCM_IN	24	DI	PCM data input.	1.8V power domain.
PCM_OUT	25	DO	PCM data output.	1.8V power domain.
PCM_SYNC	26	IO	PCM data frame sync signal.	1.8V power domain.
PCM_CLK	27	IO	PCM data bit clock.	1.8V power domain.
I2C_SCL	41	DO	I2C serial clock.	Require external pull-up resistor.
I2C_SDA	42	IO	I2C serial data.	Require external pull-up resistor.

Clock and mode can be configured by AT command, and the default configuration is master mode using short sync data format with 2048kHz PCM_CLK and 8kHz PCM_SYNC. In addition, UC20's firmware has integrated the configuration on NAU8814 application with I2C interface. Refer to **document [1]** about the command **AT+QDAI** for details.

The following figure shows the reference design of PCM interface with external codec IC.

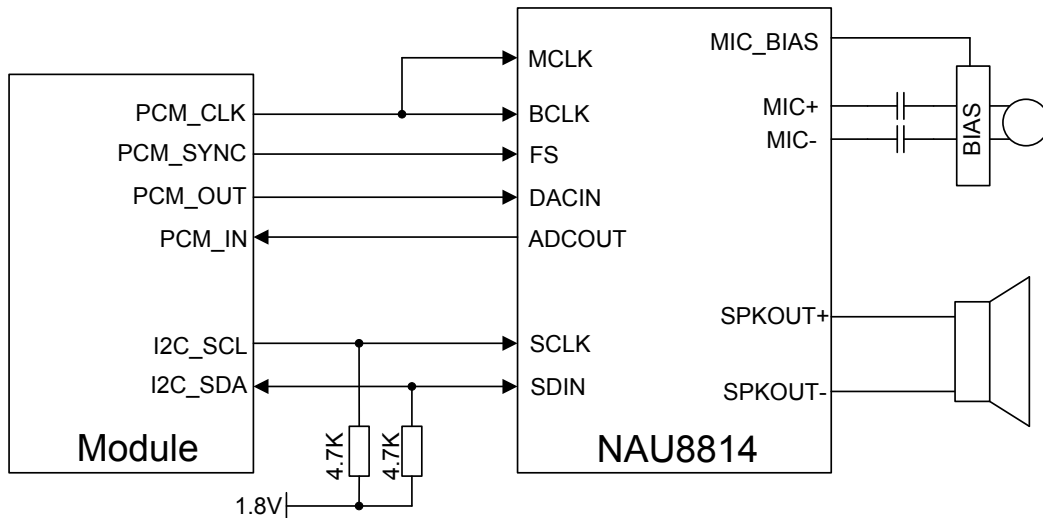

Figure 30: Reference Circuit of PCM Application with Audio Codec

NOTES

1. It is recommended to reserved RC (R=22Ω, C=22pF) circuit on the PCM lines, especially for PCM_CLK.
2. UC20 work as a master device pertaining to I2C interface.

3.14. ADC Function

The module provides two analog-to-digital converters (ADC) to digitize the analog signal to 15-bit digital data such as battery voltage, temperature and so on. Using AT command **AT+QADC=0** can read the voltage value on ADC0 pin. Using AT command **AT+QADC=1** can read the voltage value on ADC1 pin. For more details of these AT commands, please refer to **document [1]**.

In order to improve the accuracy of ADC, the trace of ADC should be surrounded by ground.

Table 17: Pin Definition of the ADC

Pin name	Pin NO.	Description
ADC0	45	General purpose analog to digital converter.
ADC1	44	General purpose analog to digital converter.

The following table describes the characteristic of the ADC function.

Table 18: Characteristic of the ADC

Parameter	Min.	Typ.	Max.	Unit
ADC0 voltage range	0.2		2.1	V
ADC1 voltage range	0.2		4.2	V
ADC resolution		15		bits
Offset error		3.5		%
Gain error		2.5		%

3.15. Network Status Indication

The network indication pins can be used to drive a network status indicator LED. The module provides two pins which are NET_MODE and NET_STATUS. The following tables describe pin definition and logic level changes in different network status.

Table 19: Pin Definition of Network Indicator

Pin Name	Pin No.	I/O	Description	Comment
NET_MODE	5	DO	Indicate the module network registration mode.	1.8V power domain.
NET_STATUS	6	DO	Indicate the module network activity status.	1.8V power domain.

Table 20: Working State of the Network Indicator

Pin name	Status	Description
NET_MODE	Always High.	Registered in 3G network.
	Always Low.	Others.
NET_STATUS	Flicker slowly (200ms High/1800ms Low).	Networks searching.
	Flicker slowly (1800ms High/200ms Low).	Idle.
	Flicker quickly (125ms High/125ms Low).	Data transfer is ongoing.
	Always High.	Voice calling.

A reference circuit is shown in the following figure.

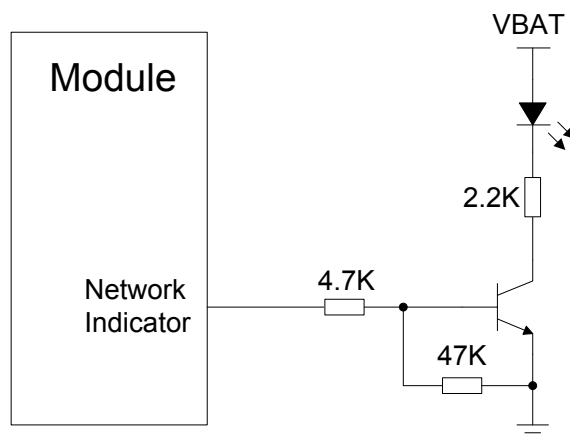

Figure 31: Reference Circuit of the Network Indicator

3.16. Operating Status Indication

3.16.1. STATUS

The STATUS pin is an open drain output for indicating the module operation status. You can connect it to a GPIO of DTE with pulled up, or as LED indication circuit as below. When the module is turned on normally, the STATUS will present the low state. Otherwise, the STATUS will present high-impedance state.

Table 21: Pin Definition of STATUS

Pin Name	Pin No.	I/O	Description	Comment
STATUS	61	OD	Indicate the module operation status.	Require external pull-up.

The following figure shows different design circuit of STATUS, you can choose either one according to your application demands.

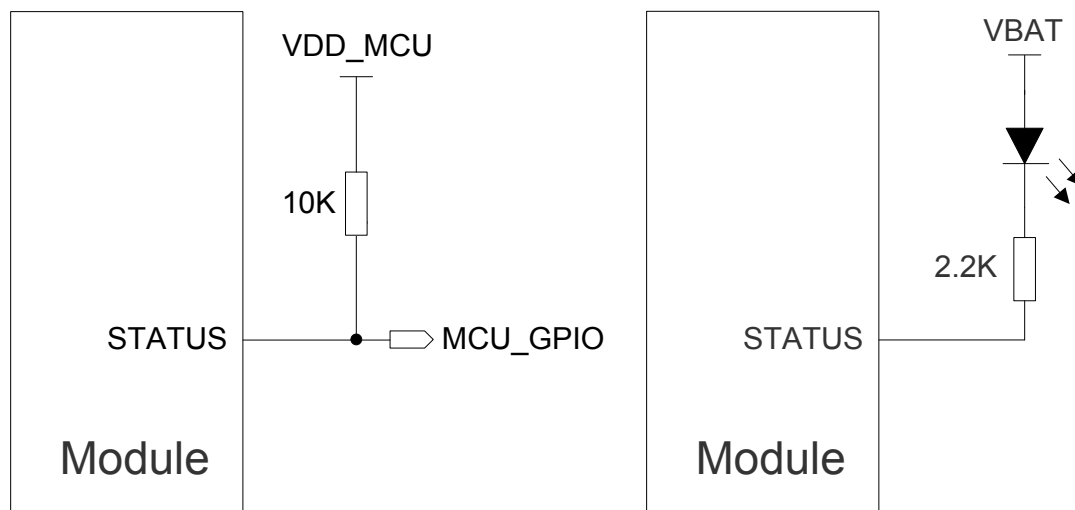

Figure 32: Reference Circuit of the STATUS

3.16.2. SLEEP_IND

The SLEEP_IND is an indicated pin for judging whether the module is in sleep mode or not. When the module enters into the sleep mode, the SLEEP_IND will output a logic high level. So you can use the SLEEP_IND for low current indication. The following table shows the pin definition of SLEEP_IND.

Table 22: Pin Definition of SLEEP_IND

Pin Name	Pin No.	I/O	Description	Comment
SLEEP_IND	3	DO	Indicate the sleep status.	1.8V power domain. Outputs high level when the module is in sleep mode.

A reference circuit is shown in the following figure.

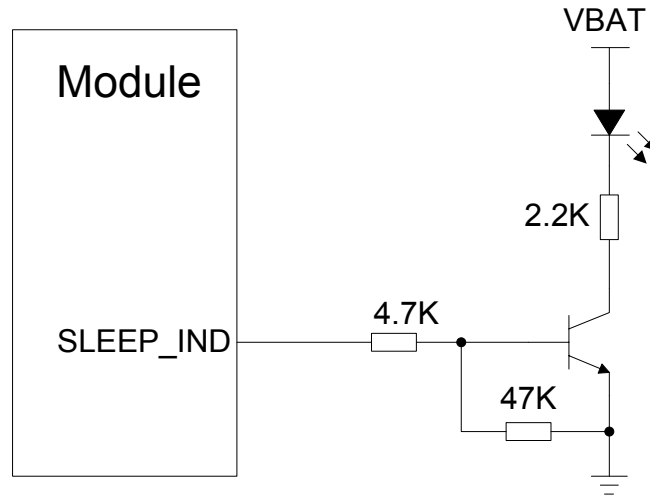

Figure 33: Reference Circuit of the SLEEP_IND

3.17. Behavior of the RI

You can use command **AT+QCFG="risignalttype", "physical"** to configure RI behavior:

No matter which port URC is presented on, URC will trigger the behavior on RI pin.

NOTE

URC can be output from UART port, USB AT port and USB modem port by command **AT+QURCCFG**. The default port is USB AT port.

In additional, RI behavior can be configured flexible. The default behavior of the RI is shown as below.

Table 23: Behavior of the RI

State	Response
Idle	RI keeps high level.
URC	RI outputs 120ms low pulse when new URC returns.

The RI behavior can be changed by command **AT+QCFG="urc/ri/ring"**, refer to **document [1]** for details.

4 GNSS Receiver

4.1. General Description

UC20 includes a fully integrated global navigation satellite system solution that supports the latest generation gpsOne Gen8 of Qualcomm (GPS and GLONASS). Compared with GPS only, dual systems increase usable constellation, reduce coverage gaps and TTFF, and increase positioning accuracy, especially in rough urban environments.

UC20 works in standalone mode, allows device to demodulate GNSS assistance data, calculate position without any assistance from the network, suitable for various application needing lowest-cost, accurate position determination. UC20 supports Qualcomm gpsOneXTRA technology (one kind of A-GNSS), which will download XTRA file from the internet server to enhance the TTFF. XTRA file contains predicted GPS and GLONASS satellites coordinates and clock biases valid for up to 7days. It is the best if XTRA file is downloaded once every 1-2 days. And UC20 also supports SBAS (including WAAS, EGNOS and MSAS), which will improve fix accuracy.

UC20 provides power-saving solution named DPO (Dynamic Power Optimization), which attempts to turn off GNSS RF parts, reduces current consumption by 50% at most without impact on TTFF and extends battery life, maximizes talk and standby time as well.

UC20 supports standard NMEA-0183 protocol, and outputs NMEA sentences with 1Hz via USB interface by default.

By default, UC20 GNSS engine is switched off, it has to be switched on with AT command. For more details about GNSS engine technology and configurations, refer to **document [7]**.

4.2. GNSS Performance

The following table shows UC20 GNSS performance.

Table 24: GNSS Performance

Parameter	Description	Conditions	Typ.	Unit
Sensitivity (GNSS)	Cold start	Autonomous	-144	dBm
		With LNA	-147	dBm
	Reacquisition	Autonomous	-154	dBm
		With LNA	-159	dBm
	Tracking	Autonomous	-155	dBm
		With LNA	-160	dBm
TTFF (GNSS)	Cold start @open sky	Autonomous	32	s
		XTRA enabled	22	s
	Warm start @open sky	Autonomous	29	s
		XTRA enabled	3	s
	Hot start @open sky	Autonomous	2.5	s
		XTRA enabled	2	s
Accuracy (GNSS)	CEP-50	Autonomous @open sky	<1.5	m

NOTES

1. Tracking sensitivity: The lowest GPS signal level at the antenna port which the module does not fail to fix within 5 minutes by reducing signal intensity.
2. Reacquisition sensitivity: The lowest GPS signal level at the antenna port which the module fixes within 3 minutes by increasing signal intensity.
3. Cold start sensitivity: The lowest GPS signal level at the antenna port which the module fixes within 3 minutes by executing cold start command.

4.3. Layout Guideline

The following layout guideline should be taken into account in your design.

- Maximize the distance between the GNSS antenna and the main UMTS antenna.
- Noisy digital circuits such as the USIM card, USB interface, Camera module, Display connector and SD card should be away from the antenna.
- Use ground vias around the GNSS trace and sensitive analog signal traces to provide coplanar isolation and protection.
- Keep 50 ohm characteristic impedance of the ANT_GNSS trace.

Refer to **chapter 5** for GNSS reference design and antenna consideration.

5 Antenna Interface

UC20 antenna interface includes a main UMTS antenna, an optional UMTS Rx-diversity antenna, which is used to improve UMTS's receiving performance, and a GNSS antenna. The antenna interface has an impedance of 50Ω.

5.1. UMTS Antenna Interface

5.1.1. Pin Definition

The main antenna and UMTS Rx-diversity antenna pins definition are shown below.

Table 25: Pin Definition of the RF Antenna

Pin Name	Pin No.	I/O	Description	Comment
ANT_MAIN	49	IO	Main antenna	50Ω impedance
ANT_DIV	35	AI	Diversity antenna	50Ω impedance

5.1.2. Operating Frequency

Table 26: The Module Operating Frequencies

Band	Receive	Transmit	Unit
UMTS 1900	1930 ~ 1990	1850 ~ 1910	MHz
UMTS 850	869 ~ 894	824 ~ 849	MHz

5.1.3. Reference Design

The reference design of main antenna and UMTS Rx-diversity antenna is shown as below. It should reserve a π -type matching circuit for better RF performance. The capacitors are not mounted by default.

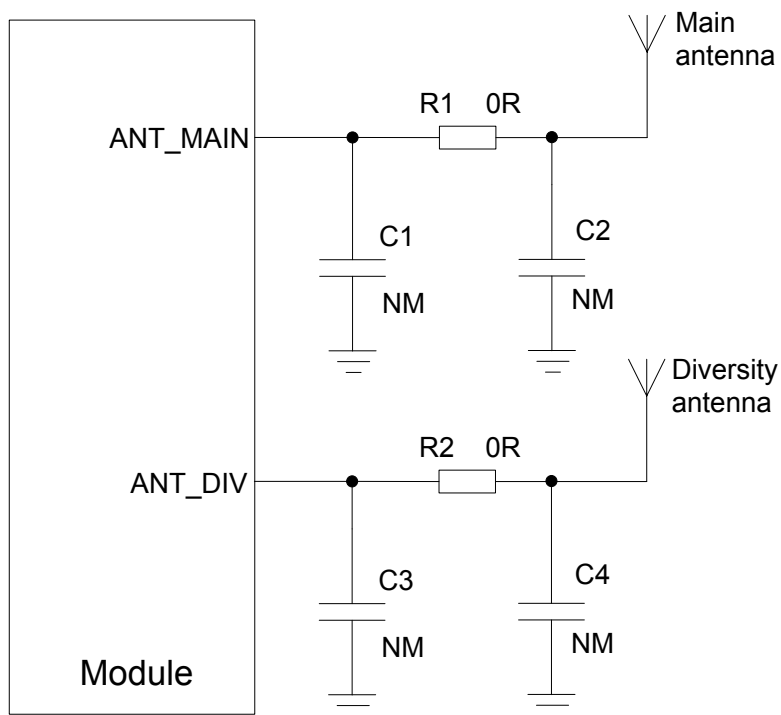

Figure 34: Reference Circuit of Antenna Interface

NOTE

Keep a proper distance between main antenna and diversity antenna to improve the receiving sensitivity.

5.2. GNSS Antenna Interface

The following tables show the GNSS antenna pin definition and frequency specification.

Table 27: Pin Definition of GNSS Antenna

Pin Name	Pin No.	I/O	Description	Comment
ANT_GNSS	47	AI	GNSS antenna	50Ω impedance
VDD_2V85	34	PO	Power for external LNA or	Vnorm=2.85V

active antenna.

Table 28: GNSS Frequency

Type	Frequency	Unit
GPS	1575.42±1.023	MHz
GLONASS	1597.5~1605.8	MHz

5.2.1. Reference Design for Passive Antenna

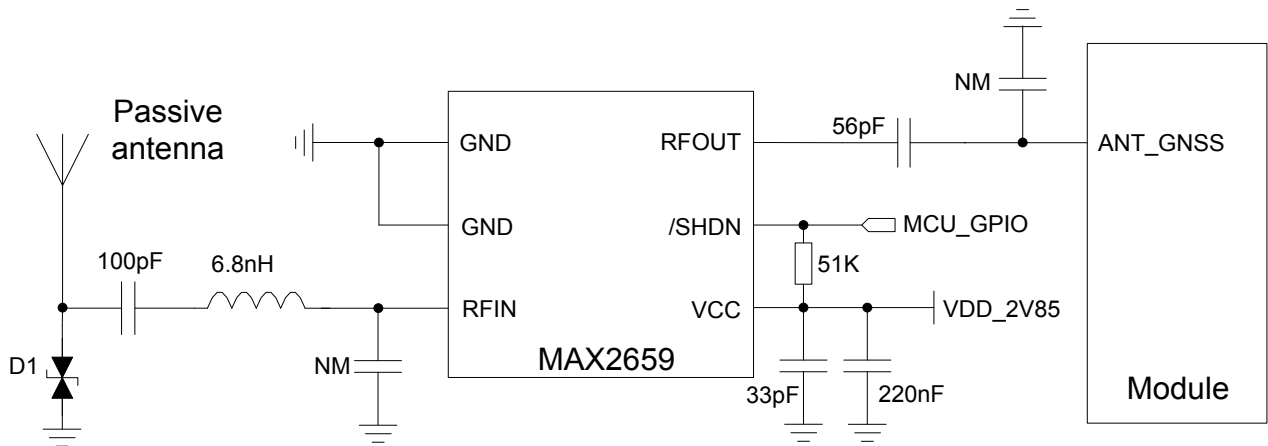

Figure 35: Reference Circuit of GNSS Passive Antenna

5.2.2. Reference Design for Active Antenna

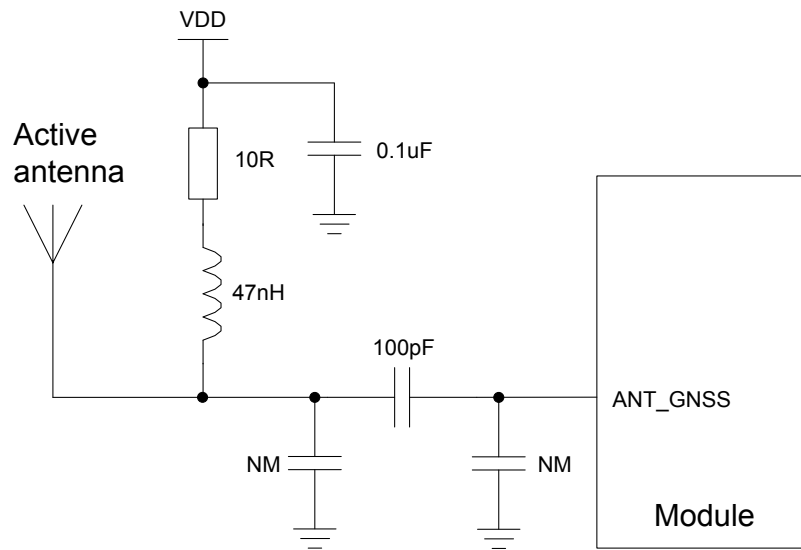

Figure 36: Reference Circuit of GNSS Active Antenna

NOTES

1. You can choose the corresponding reference circuit above according to your demands on antenna circuit design.
2. MAX2659 is the recommended LNA chip. You can disable LNA to save power with one GPIO shown in above figure. Pay attention to this pin's voltage level.
3. VDD supplies power for active antenna. You can choose the right VDD according to the requirements for active antenna. This power circuit is not needed if passive antenna is applied here.
4. All NM capacitors are reserved for adjusting RF performance.
5. The capacitance of ESD component D1 should be less than 1Pf (e.g. LXES15AAA1-100).

5.3. Antenna Installation

5.3.1. Antenna Requirement

The following table shows the requirement on /UMTS antenna and GNSS antenna.

Table 29: Antenna Requirements

Type	Requirements
GNSS	Frequency range: 1565~1607 MHz Polarization: RHCP or linear VSWR: < 2 (Typ.) Passive antenna gain: > 0dBi Active antenna noise figure: < 1.5dB Active antenna gain: > -2dBi Active antenna embedded LNA gain: 20dB (Typ.) Active antenna total gain: > 18dBi (Typ.)

5.3.2. Install the Antenna with RF Connector

The following figure is the antenna installation with RF connector provided by HIROSE. The recommended RF connector is UF.L-R-SMT.

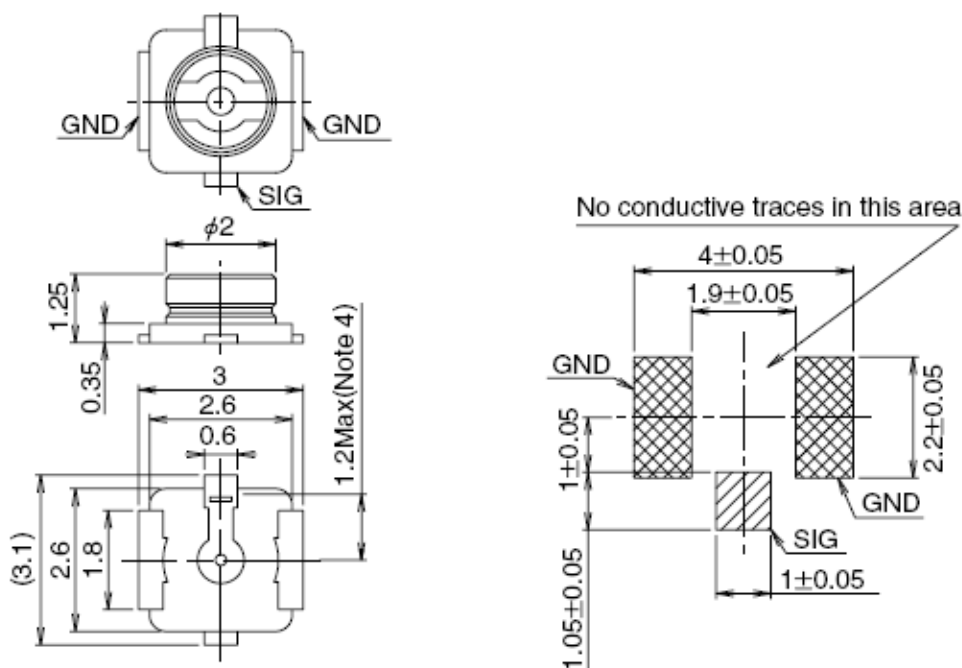

Figure 37: Dimensions of the UF.L-R-SMT Connector (Unit: mm)

You can use U.FL-LP serial connector listed in the following figure to match the UF.L-R-SMT.

Part No.	U.FL-LP-040	U.FL-LP-066	U.FL-LP(V)-040	U.FL-LP-062	U.FL-LP-088
					
Mated Height	2.5mm Max. (2.4mm Nom.)	2.5mm Max. (2.4mm Nom.)	2.0mm Max. (1.9mm Nom.)	2.4mm Max. (2.3mm Nom.)	2.4mm Max. (2.3mm Nom.)
Applicable cable	Dia. 0.81mm Coaxial cable	Dia. 1.13mm and Dia. 1.32mm Coaxial cable	Dia. 0.81mm Coaxial cable	Dia. 1mm Coaxial cable	Dia. 1.37mm Coaxial cable
Weight (mg)	53.7	59.1	34.8	45.5	71.7
RoHS	YES				

Figure 38: Mechanicals of UF.L-LP Connectors

The following figure describes the space factor of mated connector

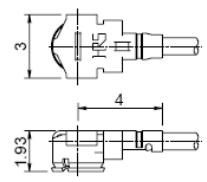
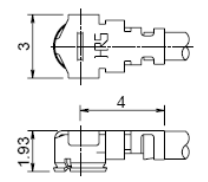
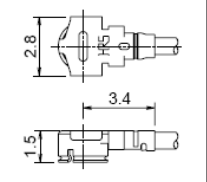
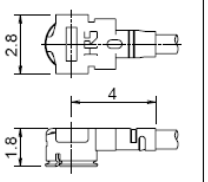
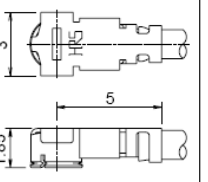
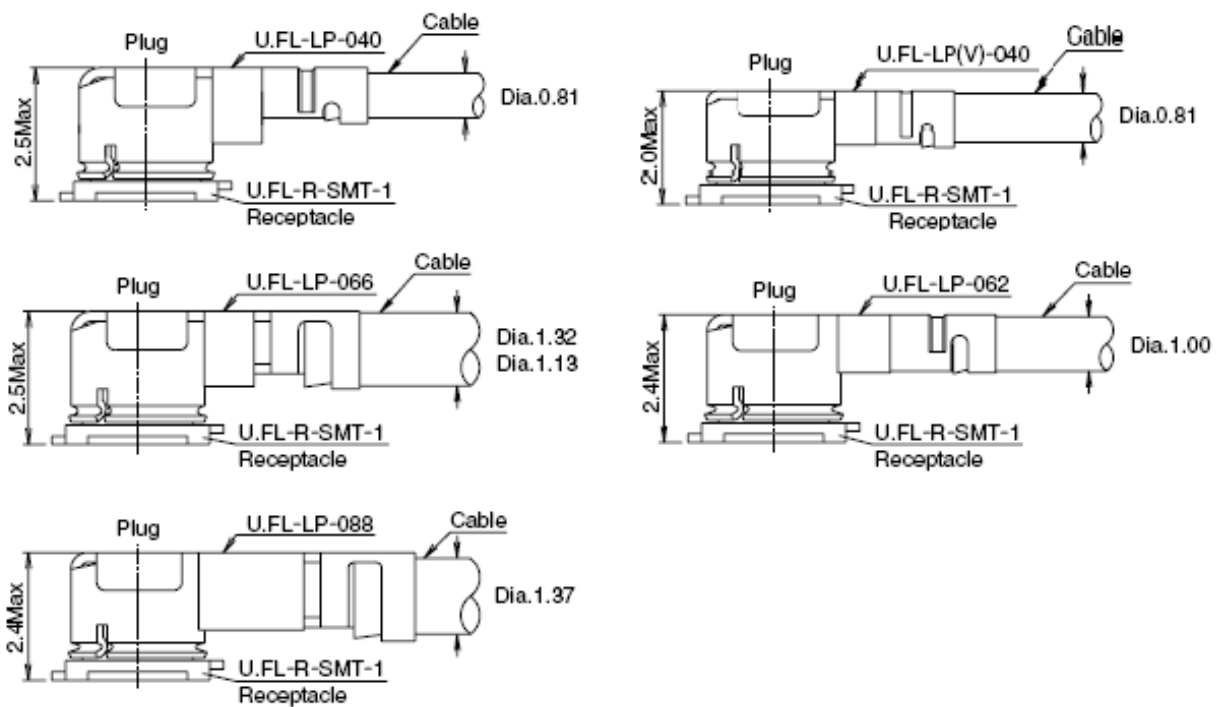

Figure 39: Space Factor of Mated Connector (Unit: mm)

For more details, please visit <http://www.hirose.com>.

6 Electrical, Reliability and Radio Characteristics

6.1. Absolute Maximum Ratings

Absolute maximum ratings for power supply and voltage on digital and analog pins of module are listed in the following table:

Table 30: Absolute Maximum Ratings

Parameter	Min.	Max.	Unit
VBAT_RF/VBAT_BB	-0.3	4.7	V
USB_VBUS	-0.3	5.5	V
Peak current of VBAT_BB	0	0.8	A
Peak current of VBAT_RF	0	1.8	A
Voltage at digital pins	-0.3	2.3	V
Voltage at ADC0	0	2.1	V
Voltage at ADC1	0	4.2	V

6.2. Power Supply Ratings

Table 31: The Module Power Supply Ratings

Parameter	Description	Conditions	Min.	Typ.	Max.	Unit
VBAT	VBAT_BB and VBAT_RF	Voltage must stay within the min/max values, including voltage drop, ripple and spikes.	3.4	3.8	4.3	V
USB_VBUS	USB detection		3.0	5.0	5.25	V

6.3. Operating Temperature

The operating temperature is listed in the following table.

Table 32: Operating Temperature

Parameter	Min	Typ.	Max	Unit
Normal Temperature	-35	25	75	°C
Restricted Operation ¹⁾	-40~ -35		75 ~ 85	°C
Storage Temperature	-45		90	°C

NOTE

- “1)” When the module works within the temperature range, the deviations from the RF specification may occur. For example, the frequency error or the phase error would increase.
- The maximum surface temperature may be up to 100°C when module works at 85°C ambient temperature.

6.4. Current Consumption

The values of current consumption are shown below.

Table 33: The Module Current Consumption

Parameter	Description	Conditions	Min.	Typ.	Max.	Unit
I _{VBAT}	OFF state supply current	Power down		45		uA
		Sleep (USB disconnected) @ DRX=6		2.0		mA
		Sleep (USB disconnected) @ DRX=7		1.7		mA
	WCDMA supply current (GNSS off)	Sleep (USB disconnected) @ DRX=8		1.5		mA
		Sleep (USB disconnected) @ DRX=9		1.4		mA
		Idle (USB disconnected) @ DRX=6		14.0		mA
		Idle (USB connected) @ DRX=6		33.4		mA
		UMTS Band I HSDPA @max power		517		mA
		UMTS Band I HSUPA @max power		497		mA
		UMTS Band II HSDPA @max power		521		mA
	WCDMA data transfer (GNSS off)	UMTS Band II HSUPA @max power		502		mA
		UMTS Band V HSDPA @max power		505		mA
		UMTS Band V HSUPA @max power		480		mA
		UMTS Band VIII HSDPA @max power		429		mA
		UMTS Band VIII HSUPA @max power		429		mA
		UMTS Band I @max power		445		mA
	WCDMA voice call	UMTS Band II @max power		484		mA
		UMTS Band V @max power		475		mA
		UMTS Band VIII @max power		387		mA
		GNSS Off			33.4	
	Cold Start (Autonomous)	Idle, USB connected @ DRX=6		80.6		mA
	Tracking (Autonomous)			71.2		mA

NOTE

GNSS tracking current is tested in the following conditions:

- For Cold Start, 10 minutes after First Fix.
- For Hot Start, 15 seconds after First Fix.

6.5. RF Output Power

The following table shows the RF output power of UC20 module.

Table 34: Conducted RF Output Power

Frequency	Max.	Min.
UMTS 1900	22.5dBm+1/-1dB	<-50dBm
UMTS 850	22.5dBm+1/-1dB	<-50dBm

6.6. RF Receiving Sensitivity

The following table shows the conducted RF receiving sensitivity of UC20 module.

Table 35: Conducted RF Receiving Sensitivity

Frequency	Receive Sensitivity (Typ.)
UMTS 1900	-110dBm
UMTS 850	-110dBm

6.7. Electrostatic Discharge

The module is not protected against electrostatics discharge (ESD) in general. Consequently, it is subject to ESD handling precautions that typically apply to ESD sensitive components. Proper ESD handling and packaging procedures must be applied throughout the processing, handling and operation of any application that incorporates the module.

The following table shows the module electrostatics discharge characteristics.

Table 36: Electrostatics Discharge Characteristics

Tested Points	Contact Discharge	Air Discharge	Unit
VBAT, GND	±5	±10	kV
All antenna interfaces	±4	±8	kV
Other interfaces	±0.5	±1	kV

7 Mechanical Dimensions

This chapter describes the mechanical dimensions of the module. All dimensions are measured in mm.

7.1. Mechanical Dimensions of the Module

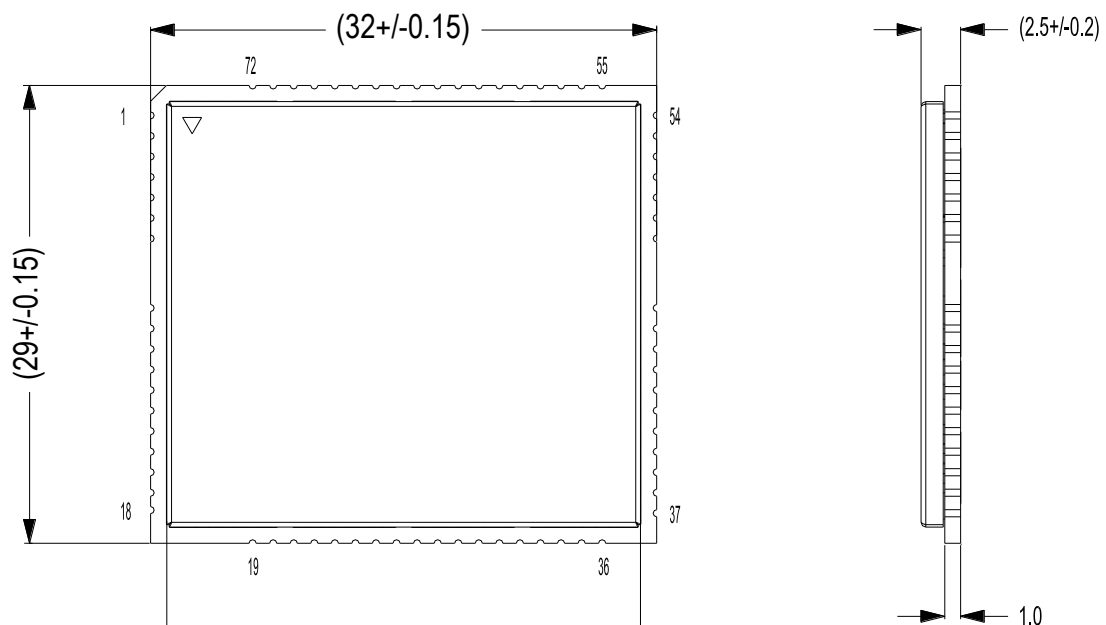

Figure 40: UC20 Top and Side Dimensions

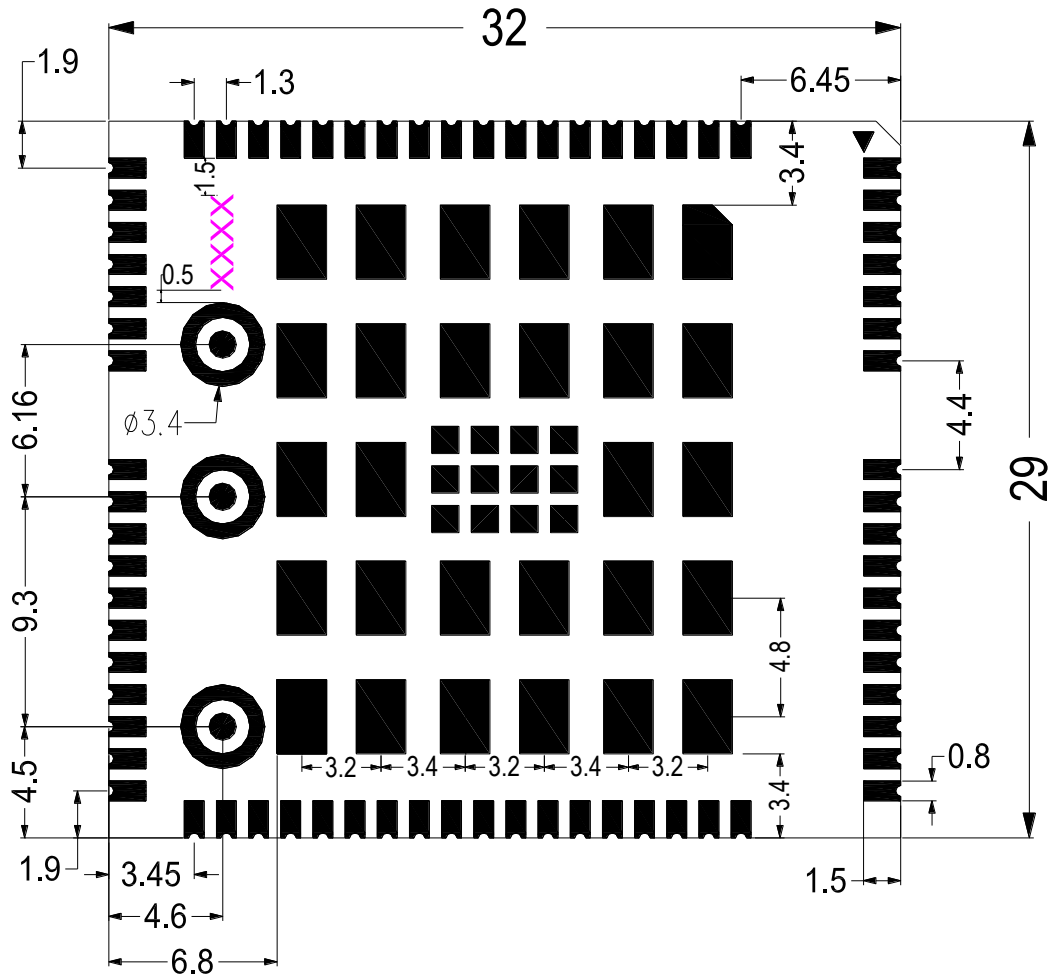

Figure 41: UC20 Bottom Dimensions (Bottom View)

NOTE

“XXXX” in pink on above figure is the PCB board code in the exposed copper.

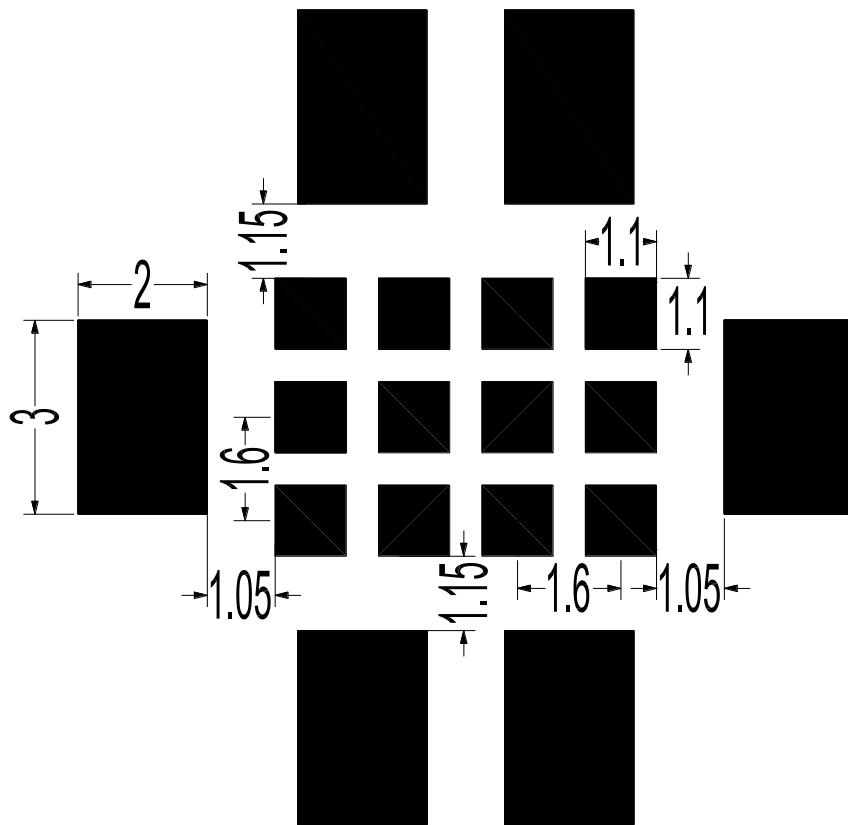

Figure 42: Bottom Pads Dimensions (Bottom View)

7.2. Footprint of Recommendation

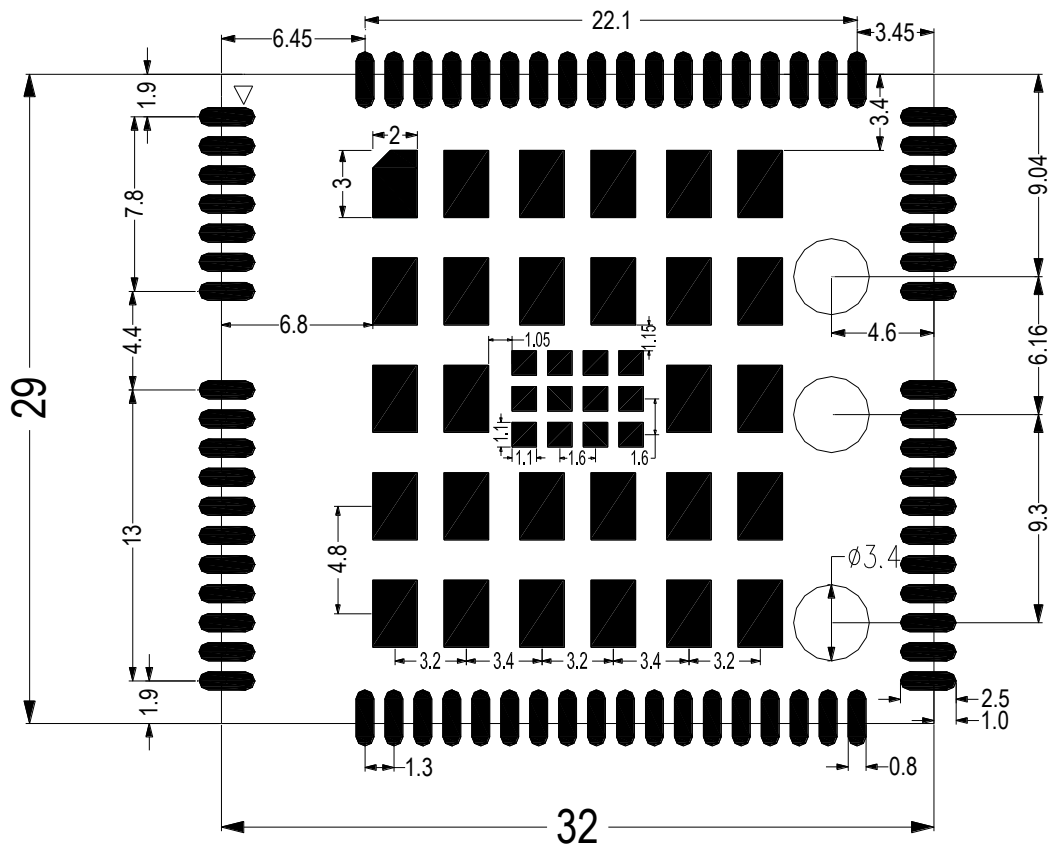

Figure 43: Recommended Footprint (Top View)

NOTES

1. Keep out the area below the test point (circular area on the above figure) in the host PCB.
2. In order to maintain the module, keep about 3mm between the module and other components in the host PCB.

7.3. Top View of the Module



Figure 44: Top View of the Module

7.4. Bottom View of the Module

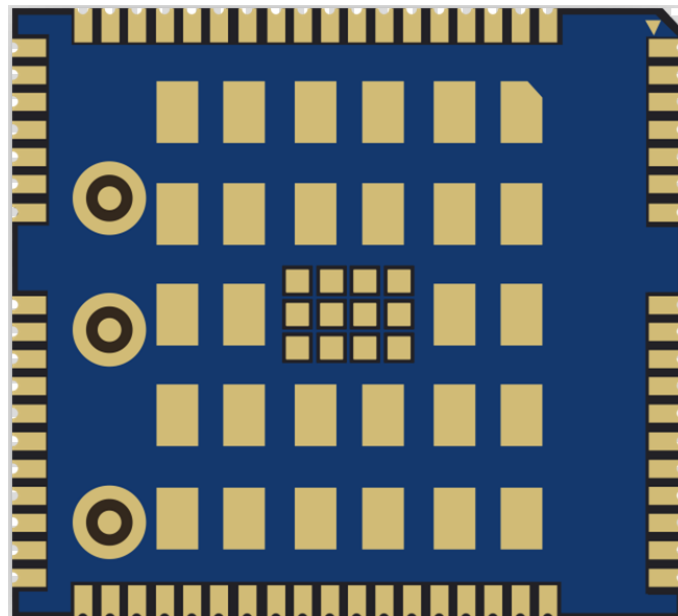

Figure 45: Bottom View of the Module

8 Storage and Manufacturing

8.1. Storage

UC20 is stored in the vacuum-sealed bag. The restriction of storage condition is shown as below.

Shelf life in sealed bag is 12 months at $< 40^{\circ}\text{C} / 90\% \text{RH}$.

After this bag is opened, devices that will be subjected to reflow solder or other high temperature process must be:

- Mounted within 72 hours at factory conditions of $\leq 30^{\circ}\text{C} / 60\% \text{RH}$.
- Stored at $< 10\% \text{RH}$.

Devices require bake, before mounting, if:

- Humidity indicator card is $> 10\%$ when read $23^{\circ}\text{C} \pm 5^{\circ}\text{C}$.
- Mounted for more than 72 hours at factory conditions of $\leq 30^{\circ}\text{C} / 60\% \text{RH}$.

If baking is required, devices may be baked for 48 hours at $125^{\circ}\text{C} \pm 5^{\circ}\text{C}$.

NOTE

As plastic container cannot be subjected to high temperature, Module needs to be taken out from container to high temperature (125°C) bake. If shorter bake times are desired, please refer to IPC/JEDECJ-STD-033 for bake procedure.

8.2. Manufacturing and Welding

The squeegee should push the paste on the surface of the stencil that makes the paste fill the stencil openings and penetrate to the PCB. The force on the squeegee should be adjusted so as to produce a clean stencil surface on a single pass. To ensure the module soldering quality, the thickness of stencil at the hole of the module pads should be 0.18mm. For details, please refer to **document [6]**.

It is suggested that peak reflow temperature is 235 ~ 245°C (for SnAg3.0Cu0.5 alloy). Absolute max reflow temperature is 260°C. To avoid damage to the module when it was repeatedly heated, it is suggested that the module should be mounted after the first panel has been reflowed. The following picture is the actual diagram which we have operated.

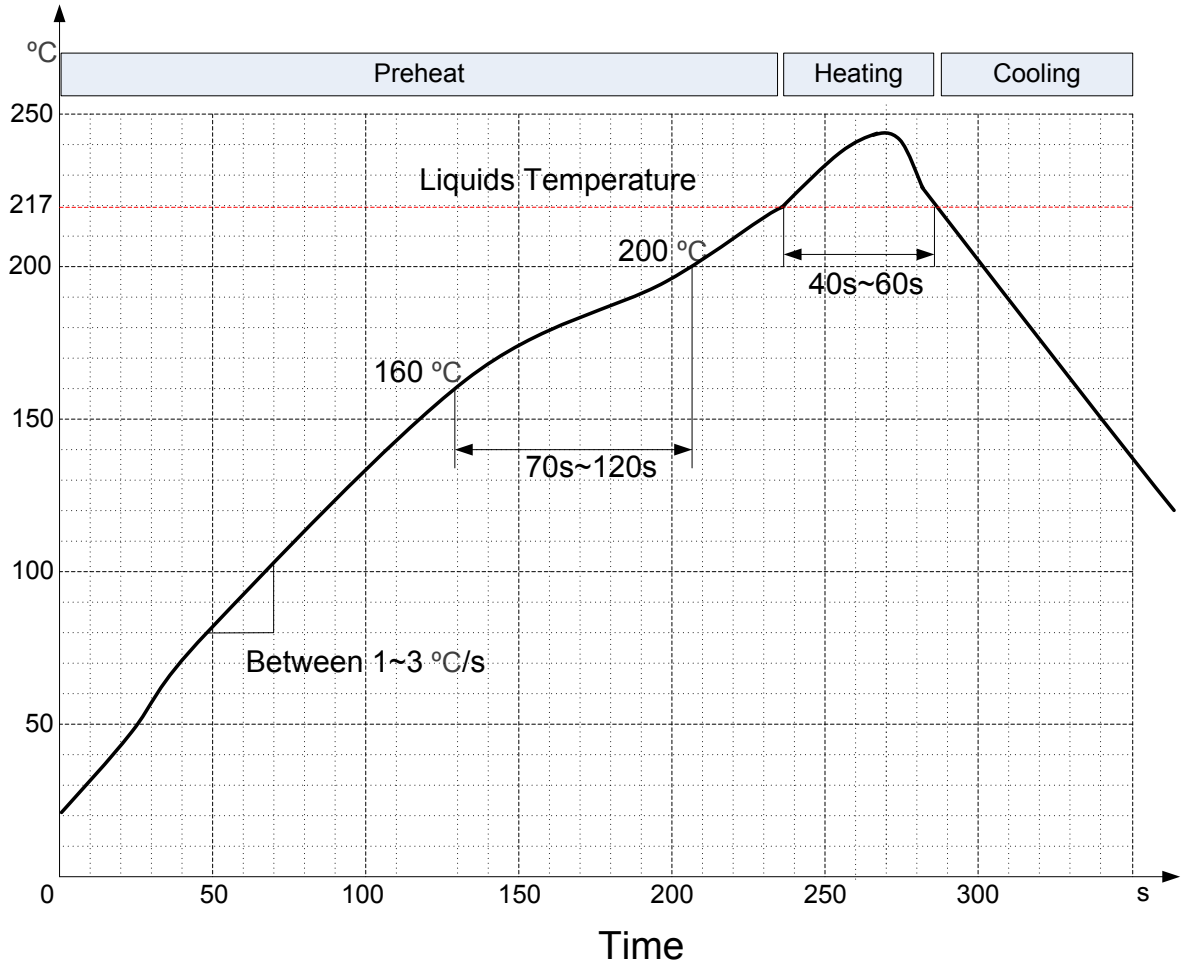

Figure 46: Liquids Temperature

8.3. Packaging

UC20 is packaged in the tap and reel carriers. One reel is 11.53m length and contains 250pcs modules. The figure below shows the package details, measured in mm.

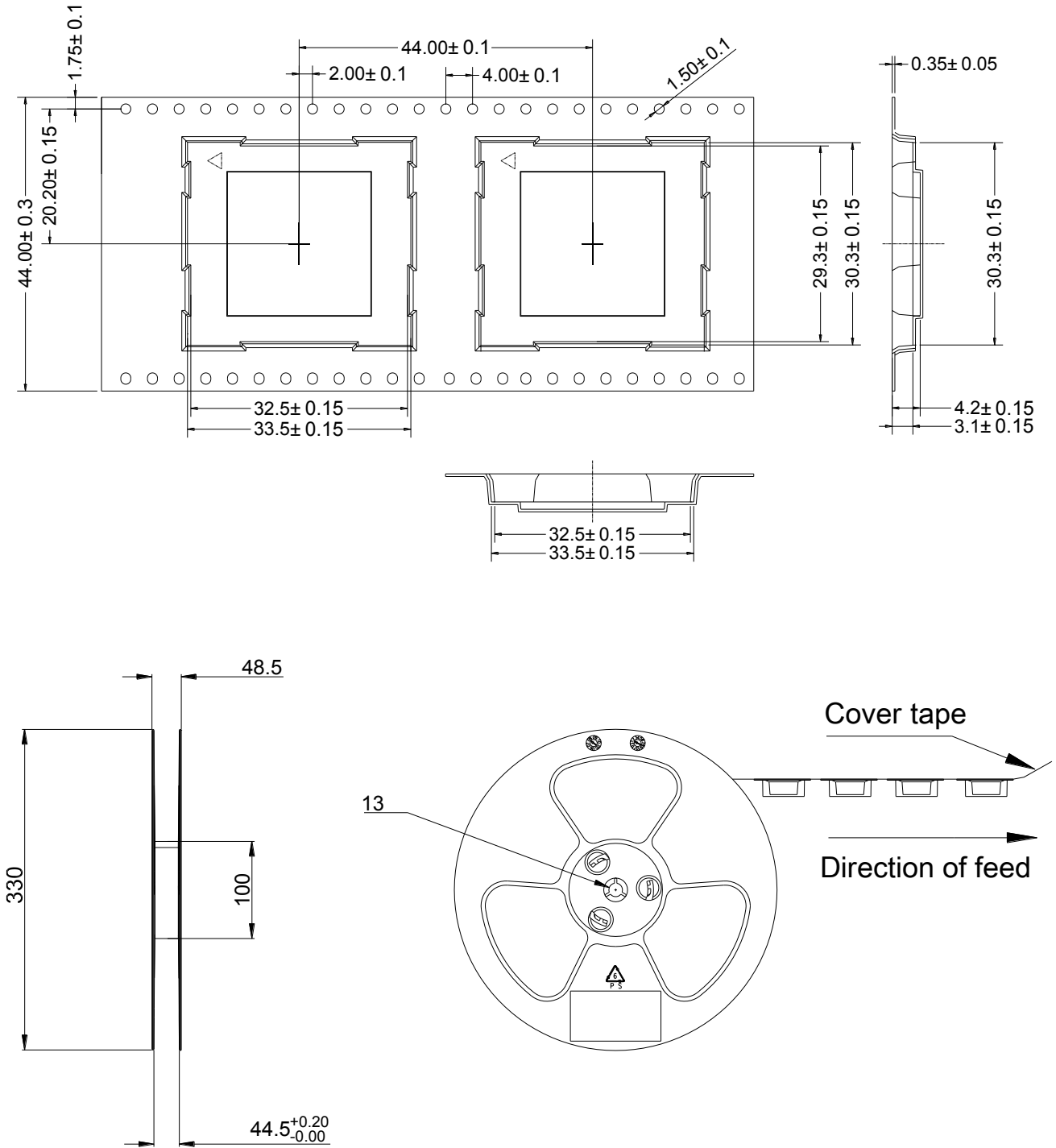

Figure 47: Carrier Tape

9 Appendix A Reference

Table 37: Related Documents

SN	Document Name	Remark
[1]	UC20_AT_Commands_Manual	UC20 AT Commands Manual
[2]	UC20_EVB_User_Guide	UC20 EVB User Guide
[3]	UC20_Reference_Design	UC20 Reference Design
[4]	UC20&M10_Reference_Design	UC20 and M10 Compatible Reference Design
[5]	UC20&M10_Compatibility_Design	UC20 and M10 Compatibility Design Specification
[6]	Module_Secondary_SMT_User_Guide	Module Secondary SMT User Guide
[7]	UC20_GNSS_AT_Commands_Manual	UC20 GNSS AT Commands Manual

Table 38: Terms and Abbreviations

Abbreviation	Description
AMR	Adaptive Multi-rate
ARP	Antenna Reference Point
bps	bits per second
CHAP	Challenge Handshake Authentication Protocol
CMUX	Customer
CS	Coding Scheme
CSD	Circuit Switched Data
CTS	Clear To Send
DRX	Discontinuous Reception

DCE	Data Communications Equipment (typically module)
DTE	Data Terminal Equipment (typically computer, external controller)
DTR	Data Terminal Ready
DTX	Discontinuous Transmission
EFR	Enhanced Full Rate
ESD	Electrostatic Discharge
FR	Full Rate
GLONASS	GLObalnaya NAVigatsionnaya Sputnikovaya Sistema, the Russian Global Navigation Satellite System
GMSK	Gaussian Minimum Shift Keying
GNSS	Global Navigation Satellite System
GPS	Global Positioning System
GSM	Global System for Mobile Communications
HR	Half Rate
HSPA	High Speed Packet Access
I/O	Input/Output
IMEI	International Mobile Equipment Identity
Imax	Maximum Load Current
Inorm	Normal Current
LED	Light Emitting Diode
LNA	Low Noise Amplifier
MO	Mobile Originated
MS	Mobile Station (GSM engine)
MT	Mobile Terminated
PAP	Password Authentication Protocol
PBCCH	Packet Switched Broadcast Control Channel

PCB	Printed Circuit Board
PDU	Protocol Data Unit
PPP	Point-to-Point Protocol
PSK	Phase Shift Keying
QAM	Quadrature Amplitude Modulation
QPSK	Quadrature Phase Shift Keying
RF	Radio Frequency
RHCP	Right Hand Circularly Polarized
RMS	Root Mean Square (value)
RTC	Real Time Clock
Rx	Receive
SIM	Subscriber Identification Module
SMS	Short Message Service
TDMA	Time Division Multiple Access
TE	Terminal Equipment
TX	Transmitting Direction
UART	Universal Asynchronous Receiver & Transmitter
UMTS	Universal Mobile Telecommunications System
URC	Unsolicited Result Code
USIM	Universal Subscriber Identity Module
USSD	Unstructured Supplementary Service Data
V _{max}	Maximum Voltage Value
V _{norm}	Normal Voltage Value
V _{min}	Minimum Voltage Value
V _{IHmax}	Maximum Input High Level Voltage Value

V_{IHmin}	Minimum Input High Level Voltage Value
V_{ILmax}	Maximum Input Low Level Voltage Value
V_{ILmin}	Minimum Input Low Level Voltage Value
$V_{I,max}$	Absolute Maximum Input Voltage Value
$V_{I,min}$	Absolute Minimum Input Voltage Value
V_{OHmax}	Maximum Output High Level Voltage Value
V_{OHmin}	Minimum Output High Level Voltage Value
V_{OLmax}	Maximum Output Low Level Voltage Value
V_{OLmin}	Minimum Output Low Level Voltage Value
VSWR	Voltage Standing Wave Ratio
WCDMA	Wideband Code Division Multiple Access
