

GC65 Hardware Design

GSM/GPRS Module Series

Rev. GC65_Hardware_Design_V2.0

Date: 2014-01-09



Our aim is to provide customers with timely and comprehensive service. For any assistance, please contact our company headquarters:

Quectel Wireless Solutions Co., Ltd.

Room 501, Building 13, No.99, Tianzhou Road, Shanghai, China, 200233

Tel: +86 21 5108 6236

Mail: info@quectel.com

Or our local office, for more information, please visit:

<http://www.quectel.com/support/salesupport.aspx>

For technical support, to report documentation errors, please visit:

<http://www.quectel.com/support/techsupport.aspx>

GENERAL NOTES

QUECTEL OFFERS THIS INFORMATION AS A SERVICE TO ITS CUSTOMERS. THE INFORMATION PROVIDED IS BASED UPON CUSTOMERS' REQUIREMENTS. QUECTEL MAKES EVERY EFFORT TO ENSURE THE QUALITY OF THE INFORMATION IT MAKES AVAILABLE. QUECTEL DOES NOT MAKE ANY WARRANTY AS TO THE INFORMATION CONTAINED HEREIN, AND DOES NOT ACCEPT ANY LIABILITY FOR ANY INJURY, LOSS OR DAMAGE OF ANY KIND INCURRED BY USE OF OR RELIANCE UPON THE INFORMATION. ALL INFORMATION SUPPLIED HEREIN ARE SUBJECT TO CHANGE WITHOUT PRIOR NOTICE.

COPYRIGHT

THIS INFORMATION CONTAINED HERE IS PROPRIETARY TECHNICAL INFORMATION OF QUECTEL CO., LTD. TRANSMITTABLE, REPRODUCTION, DISSEMINATION AND EDITING OF THIS DOCUMENT AS WELL AS UTILIZATION OF THIS CONTENTS ARE FORBIDDEN WITHOUT PERMISSION. OFFENDERS WILL BE HELD LIABLE FOR PAYMENT OF DAMAGES. ALL RIGHTS ARE RESERVED IN THE EVENT OF A PATENT GRANT OR REGISTRATION OF A UTILITY MODEL OR DESIGN.

Copyright © Quectel Wireless Solutions Co., Ltd. 2014. All rights reserved.

About the Document

History

Revision	Date	Author	Description
1.0	2013-12-09	King HAO	Initial
2.0	2014-01-09	King HAO	<ol style="list-style-type: none">1. Update Figure 2: Pin assignment.2. Modified the mechanical dimensions and the recommended footprint of the module in Chapter 6.3. Update the function of SIM card detection.

Contents

About the Document	2
Contents	3
Table Index	5
Figure Index	6
1 Introduction	8
1.1. Safety Information.....	8
2 Product Concept	10
2.1. General Description.....	10
2.2. Directives and Standards.....	10
2.2.1. FCC Statement.....	10
2.2.2. FCC Radiation Exposure Statement.....	11
2.3. Key Features.....	11
2.4. Functional Diagram.....	13
2.5. Evaluation Board.....	14
3 Application Interface	15
3.1. Pin of Module.....	16
3.1.1. Pin Assignment.....	16
3.1.2. Pin Description.....	17
3.2. Operating Modes.....	21
3.3. Power Supply.....	22
3.3.1. Power Features of Module.....	22
3.3.2. Decrease Supply Voltage Drop.....	22
3.3.3. Reference Design for Power Supply.....	23
3.3.4. Monitor Power Supply.....	24
3.4. Power On and Down Scenarios.....	24
3.4.1. Power On.....	24
3.4.2. Power Down.....	26
3.4.2.1. Power Down Module by the PWRKEY Pin.....	27
3.4.2.2. Power Down Module by AT Command.....	28
3.4.2.3. Over-voltage or Under-voltage Automatic Shutdown.....	28
3.4.2.4. Emergency Shutdown by EMERG_OFF Pin.....	29
3.4.3. Restart.....	30
3.5. Power Saving Technology.....	31
3.5.1. Minimum Functionality Mode.....	31
3.5.2. Sleep Mode.....	31
3.5.3. Wake Up Module from Sleep Mode.....	32
3.5.4. Summary of State Transition.....	32
3.6. RTC Backup.....	32
3.7. Serial Interfaces.....	34
3.7.1. UART Port.....	36
3.7.1.1. The Features of UART Port.....	36

3.7.1.2.	The Connection of UART	37
3.7.2.	Debug and Upgrade Port	38
3.7.3.	UART Application	39
3.8.	Audio Interfaces.....	41
3.8.1.	Decrease TDD Noise and Other Noises	42
3.8.2.	Microphone Interfaces Design	43
3.8.3.	Receiver Interface Design.....	44
3.8.4.	Earphone Interface Design	46
3.8.5.	Audio Characteristics	46
3.9.	SIM Card Interface	47
3.9.1.	SIM Card Application.....	47
3.9.2.	SIM Cassette.....	49
3.10.	PCM Interface.....	52
3.11.	Behaviors of the RI	52
3.12.	Network Status Indication.....	53
4	Antenna Interface.....	55
4.1.	RF Reference Design.....	55
4.2.	RF Output Power.....	56
4.3.	RF Receiving Sensitivity.....	56
4.4.	Operating Frequencies.....	57
4.5.	RF Cable Soldering	57
5	Electrical, Reliability and Radio Characteristics	58
5.1.	Absolute Maximum Ratings.....	58
5.2.	Operating Temperature	59
5.3.	Power Supply Ratings	59
5.4.	Current Consumption	60
5.5.	Electro-static Discharge	61
6	Mechanical Dimensions	63
6.1.	Mechanical Dimensions of Module	63
6.2.	Recommended Footprint.....	65
6.3.	Top View of the Module	66
6.4.	Bottom View of the Module	66
7	Storage and Manufacturing	67
7.1.	Storage	67
7.2.	Soldering	68
7.3.	Packaging.....	69
7.3.1.	Tape and Reel Packaging	69
8	Appendix A Reference.....	71
9	Appendix B GPRS Coding Scheme	75
10	Appendix C GPRS Multi-slot Class	77

Table Index

TABLE 1: MODULE KEY FEATURES	11
TABLE 2: CODING SCHEMES AND MAXIMUM NET DATA RATES OVER AIR INTERFACE	13
TABLE 3: PIN DESCRIPTION	17
TABLE 4: OVERVIEW OF OPERATING MODES	21
TABLE 5: SUMMARY OF STATE TRANSITION	32
TABLE 6: LOGIC LEVELS OF THE UART INTERFACES	35
TABLE 7: PIN DEFINITION OF THE UART INTERFACES	35
TABLE 8: PIN DEFINITION OF AUDIO INTERFACE	41
TABLE 9: TYPICAL ELECTRET MICROPHONE CHARACTERISTICS	46
TABLE 10: TYPICAL AUDIO OUTPUT CHARACTERISTICS	46
TABLE 11: PIN DEFINITION OF THE SIM INTERFACE	47
TABLE 12: PIN DESCRIPTION OF AMPHENOL SIM CARD HOLDER	50
TABLE 13: PIN DESCRIPTION OF MOLEX SIM CARD HOLDER	51
TABLE 14: BEHAVIOURS OF THE RI	52
TABLE 15: WORKING STATE OF THE NETLIGHT	53
TABLE 16: PIN DEFINITION OF THE RF_ANT	55
TABLE 17: THE MODULE CONDUCTED RF OUTPUT POWER	56
TABLE 18: THE MODULE CONDUCTED RF RECEIVING SENSITIVITY	56
TABLE 19: THE MODULE OPERATING FREQUENCIES	57
TABLE 20: ABSOLUTE MAXIMUM RATINGS	58
TABLE 21: OPERATING TEMPERATURE	59
TABLE 22: THE MODULE POWER SUPPLY RATINGS	59
TABLE 23: THE MODULE CURRENT CONSUMPTION	60
TABLE 24: THE ESD ENDURANCE (TEMPERATURE: 25°C, HUMIDITY: 45 %)	62
TABLE 25: RELATED DOCUMENTS	71
TABLE 26: TERMS AND ABBREVIATIONS	72
TABLE 27: DESCRIPTION OF DIFFERENT CODING SCHEMES	75
TABLE 28: GPRS MULTI-SLOT CLASSES	77

Figure Index

FIGURE 1: MODULE FUNCTIONAL DIAGRAM.....	14
FIGURE 2: PIN ASSIGNMENT	16
FIGURE 3: VOLTAGE DROP DURING TRANSMITTING.....	22
FIGURE 4: REFERENCE CIRCUIT FOR THE VBAT INPUT	23
FIGURE 5: REFERENCE CIRCUIT FOR POWER SUPPLY	24
FIGURE 6: REFERENCE DIAGRAM FOR SWITCHING POWER CONVERTER	24
FIGURE 7: TURN ON THE MODULE WITH AN OC DRIVER.....	25
FIGURE 8: TURN ON THE MODULE WITH A BUTTON	25
FIGURE 9: TURN-ON TIMING	26
FIGURE 10: TURN-OFF TIMING	27
FIGURE 11: AN OC DRIVER FOR EMERG_OFF	29
FIGURE 12: REFERENCE CIRCUIT FOR EMERG_OFF BY BUTTON	29
FIGURE 13: TIMING OF RESTARTING SYSTEM.....	30
FIGURE 14: TIMING OF RESTARTING SYSTEM AFTER EMERGENCY SHUTDOWN	30
FIGURE 15: RTC SUPPLIED FROM A NON-CHARGEABLE BATTERY.....	33
FIGURE 16: RTC SUPPLIED FROM A RECHARGEABLE BATTERY	33
FIGURE 17: RTC SUPPLIED FROM A CAPACITOR	33
FIGURE 18: CHARGING CHARACTERISTICS OF SEIKO'S XH414H-IV01E	34
FIGURE 19: REFERENCE DESIGN FOR FULL-FUNCTION UART	37
FIGURE 20: REFERENCE DESIGN FOR UART PORT.....	38
FIGURE 21: REFERENCE DESIGN FOR UART PORT WITH HARDWARE FLOW CONTROL	38
FIGURE 22: THE CONNECTION OF FIRMWARE DEBUGGING AND UPGRADE.....	39
FIGURE 23: LEVEL MATCH DESIGN FOR 3.3V SYSTEM.....	39
FIGURE 24: LEVEL MATCH DESIGN FOR 5V SYSTEM.....	40
FIGURE 25: LEVEL MATCH DESIGN FOR RS-232.....	41
FIGURE 26: REFERENCE DESIGN FOR AIN1&AIN2.....	43
FIGURE 27: REFERENCE RECEIVER INTERFACE DESIGN OF AOUT1	44
FIGURE 28: SPEAKER INTERFACE WITH AMPLIFIER CONFIGURATION OF AOUT1.....	44
FIGURE 29: REFERENCE RECEIVER INTERFACE DESIGN OF AOUT2	45
FIGURE 30: SPEAKER INTERFACE WITH AMPLIFIER CONFIGURATION OF AOUT2.....	45
FIGURE 31: EARPHONE INTERFACE DESIGN.....	46
FIGURE 32: REFERENCE CIRCUIT FOR 8-PIN SIM CARD HOLDER	48
FIGURE 33: REFERENCE CIRCUIT FOR 6-PIN SIM CARD HOLDER	49
FIGURE 34: AMPHENOL C707 10M006 512 2 SIM CARD HOLDER.....	50
FIGURE 35: MOLEX 91228 SIM CARD HOLDER.....	51
FIGURE 36: RI BEHAVIOUR OF VOICE CALLING AS A RECEIVER	52
FIGURE 37: RI BEHAVIOUR AS A CALLER.....	53
FIGURE 38: RI BEHAVIOUR OF URC OR SMS RECEIVED	53
FIGURE 39: REFERENCE DESIGN FOR NETLIGHT	54
FIGURE 40: REFERENCE DESIGN FOR RF	55
FIGURE 41: RF SOLDERING SAMPLE	57

FIGURE 42: GC65 MODULE TOP AND SIDE DIMENSIONS (UNIT: MM).....	63
FIGURE 43: GC65 MODULE BOTTOM DIMENSIONS (UNIT: MM)	64
FIGURE 44: RECOMMENDED FOOTPRINT (UNIT: MM).....	65
FIGURE 45: TOP VIEW OF THE MODULE	66
FIGURE 46: BOTTOM VIEW OF THE MODULE.....	66
FIGURE 47: THE PICTURE OF PRINTING PASTE	68
FIGURE 48: RAMP-SOAK-SPIKE REFLOW PROFILE.....	69
FIGURE 49: DIMENSIONS OF TAPE	70
FIGURE 50: DIMENSIONS OF REEL.....	70
FIGURE 51: RADIO BLOCK STRUCTURE OF CS-1, CS-2 AND CS-3.....	75
FIGURE 52: RADIO BLOCK STRUCTURE OF CS-4.....	76

1 Introduction

This document defines the GC65 module and describes its hardware interface which are connected with your application and the air interface.

This document can help you quickly understand module interface specifications, electrical and mechanical details. Associated with application notes and user guide, you can use GC65 module to design and set up mobile applications easily.

1.1. Safety Information

The following safety precautions must be observed during all phases of the operation, such as usage, service or repair of any cellular terminal or mobile incorporating GC65 module. Manufacturers of the cellular terminal should send the following safety information to users and operating personnel and to incorporate these guidelines into all manuals supplied with the product. If not so, Quectel does not take on any liability for your failure to comply with these precautions.



Full attention must be given to driving at all times in order to reduce the risk of an accident. Using a mobile while driving (even with a handsfree kit) cause distraction and can lead to an accident. You must comply with laws and regulations restricting the use of wireless devices while driving.



Switch off the cellular terminal or mobile before boarding an aircraft. Make sure it switched off. The operation of wireless appliances in an aircraft is forbidden to prevent interference with communication systems. Consult the airline staff about the use of wireless devices on boarding the aircraft. If your device offers a Flight Mode which must be enabled prior to boarding an aircraft.



Switch off your wireless device when in hospitals or clinics or other health care facilities. These requests are desinged to prevent possible interference with sensitive medical equipment.



GSM cellular terminals or mobiles operate over radio frequency signal and cellular network and cannot be guaranteed to connect in all conditions, for example no mobile fee or an invalid SIM card. While you are in this condition and need emergent help, please remember using emergency call. In order to make or receive call, the cellular terminal or mobile must be switched on and in a service area with adequate cellular signal strength.



Your cellular terminal or mobile contains a transmitter and receiver. When it is ON , it receives and transmits radio frequency energy. RF interference can occur if it is used close to TV set, radio, computer or other electric equipment.



In locations with potentially explosive atmospheres, obey all posted signs to turn off wireless devices such as your phone or other cellular terminals. Areas with potentially exposable atmospheres including fuelling areas, below decks on boats, fuel or chemical transfer or storage facilities, areas where the air contains chemicals or particles such as grain, dust or metal powders.

2 Product Concept

2.1. General Description

GC65 is a Quad-band GSM/GPRS engine that works at frequencies of GSM850MHz, GSM900MHz, DCS1800MHz and PCS1900MHz. The GC65 features GPRS multi-slot class 10 and supports the GPRS coding schemes CS-1, CS-2, CS-3 and CS-4. For more details about GPRS multi-slot classes and coding schemes, please refer to the **Appendix B&C**.

With a tiny profile of 19mm×16.9mm×2.35mm, the module can meet almost all the requirements for M2M applications, including Vehicles and Personal Tracking, Security System, Wireless POS, Industrial PDA, Smart Metering, and Remote Maintenance & Control, etc.

GC65 is an SMD type module, which can be easily embedded into applications through its 44-pin pads. It provides abundant hardware interfaces like Audio and UART Interface.

Designed with power saving technique, the current consumption of GC65 is as low as 1.3mA in sleep mode when DRX is 5.

GC65 is integrated with Internet service protocols, such as TCP/UDP, HTTP and PPP. Extended AT commands have been developed for you to use these Internet service protocols easily.

The module fully complies with the RoHS directive of the European Union.

2.2. Directives and Standards

The GC10 module is designed to comply with the FCC statements. FCC ID: XMR201403GC65
The Host system using GC65, should have label indicated FCC ID: XMR201403GC65.

2.2.1. FCC Statement

1. This device complies with Part 15 of the FCC rules. Operation is subject to the following conditions:
 - a) This device may not cause harmful interference.
 - b) This device must accept any interference received, including interference that may cause undesired operation.

2. Changes or modifications not expressly approved by the party responsible for compliance could void the user's authority to operate the equipment.

2.2.2. FCC Radiation Exposure Statement

This equipment complies with FCC radiation exposure limits set forth for an uncontrolled environment. This equipment should be installed and operated with minimum distance 20cm between the radiator and your body as well as kept minimum 20cm from radio antenna depending on the Mobile status of this module usage. This module should NOT be installed and operating simultaneously with other radio.

The manual of the host system, which uses GC65, must include RF exposure warning statement to advice user should keep minimum 20cm from the radio antenna of GC65 module depending on the Mobile status.

Note: If a portable device (such as PDA) uses GC65 module, the device needs to do permissive change and SAR testing.

The following list of antenna is indicating the maximum permissible antenna gain.

Part Number	Frequency Range (MHz)	Peak Gain XZ-V)	Average Gain XZ-V)	VSWR	Impedance
3R007A	PCS1900:1850~1990 GSM850:824-894	1 dBi typ.	1 dBi typ.	3 max	50Ω

2.3. Key Features

The following table describes the detailed features of GC65 module.

Table 1: Module Key Features

Feature	Implementation
Power Supply	Single supply voltage: 3.3V~4.6V Typical supply voltage: 4.0V
Power Saving	Typical power consumption in sleep mode: 1.3 mA@ DRX=5 1.1 mA@ DRX=9
Frequency Bands	<ul style="list-style-type: none"> ● Quad-band: GSM850/GSM900/DCS1800/PCS1900 ● The module can search these frequency bands automatically ● The frequency bands can be set by AT command

	<ul style="list-style-type: none"> ● Compliant to GSM Phase 2/2+
Transmitting Power	<ul style="list-style-type: none"> ● Class 4 (2W) at GSM850/GSM900 ● Class 1 (1W) at DCS1800/PCS1900
GPRS Connectivity	<ul style="list-style-type: none"> ● GPRS multi-slot class 10 ● GPRS mobile station class B
Temperature Range	<ul style="list-style-type: none"> ● Normal operation: -35°C ~ +80°C ● Restricted operation: -40°C ~ -35°C and +80°C ~ +85°C ¹⁾ ● Storage temperature: -45°C ~ +90°C
DATA GPRS	<ul style="list-style-type: none"> ● GPRS data downlink transfer: max. 85.6kbps ● GPRS data uplink transfer: max. 42.8kbps ● Coding scheme: CS-1, CS-2, CS-3 and CS-4 ● Internet service protocols TCP/UDP, PPP, HTTP ● Support Packet Broadcast Control Channel (PBCCH)
USSD	Support Unstructured Supplementary Service Data
SMS	<ul style="list-style-type: none"> ● MT/MO, Text and PDU mode ● SMS storage: SIM card
SIM Interface	Support SIM card: 1.8V/3.0V
Audio Features	<p>Speech codec modes:</p> <ul style="list-style-type: none"> ● Half Rate (ETS 06.20) ● Full Rate (ETS 06.10) ● Enhanced Full Rate (ETS 06.50/06.60/06.80) ● Echo Suppression ● Echo Cancellation ● Noise Reduction
UART Interfaces	<p>UART Port:</p> <ul style="list-style-type: none"> ● Seven lines on UART port interface ● Used for AT command, GPRS data ● Support fixed baud rate from 2400bps to 460800bps ● Support autobauding from 4800bps to 115200bps <p>Debug Port:</p> <ul style="list-style-type: none"> ● Two lines on debug port interface DBG_TXD and DBG_RXD ● Used for firmware debugging and log output ● Used for firmware upgrade ● The baud rate is fixed at 921600bps
Phonebook Management	Support phonebook types: SM/ON/FD/LD
SIM Application Toolkit	Support SAT class 3, GSM 11.14 Release 99
Real Time Clock	Supported

Physical Characteristics	Size: 19±0.15×16.9±0.15×2.35±0.2mm Weight: Approx.1.3g
Firmware Upgrade	Firmware upgrade via debug port
Antenna Interface	Connected to antenna pad with 50 Ohm impedance control

NOTE

When the module works within this temperature range, the deviations from the GSM specification may occur. For example, the frequency error or the phase error will be increased.

Table 2: Coding Schemes and Maximum Net Data Rates over Air Interface

Coding Scheme	1 Timeslot	2 Timeslot	4 Timeslot
CS-1	9.05kbps	18.1kbps	36.2kbps
CS-2	13.4kbps	26.8kbps	53.6kbps
CS-3	15.6kbps	31.2kbps	62.4kbps
CS-4	21.4kbps	42.8kbps	85.6kbps

2.4. Functional Diagram

The following figure shows a block diagram of GC65 and illustrates the major functional parts.

- Radio frequency part
- Power management
- Memory
- The peripheral interface
 - Power supply
 - Turn-on/off interface
 - UART interfaces
 - Audio interfaces
 - SIM interface
 - PCM interface
 - RTC interface
 - RF interface

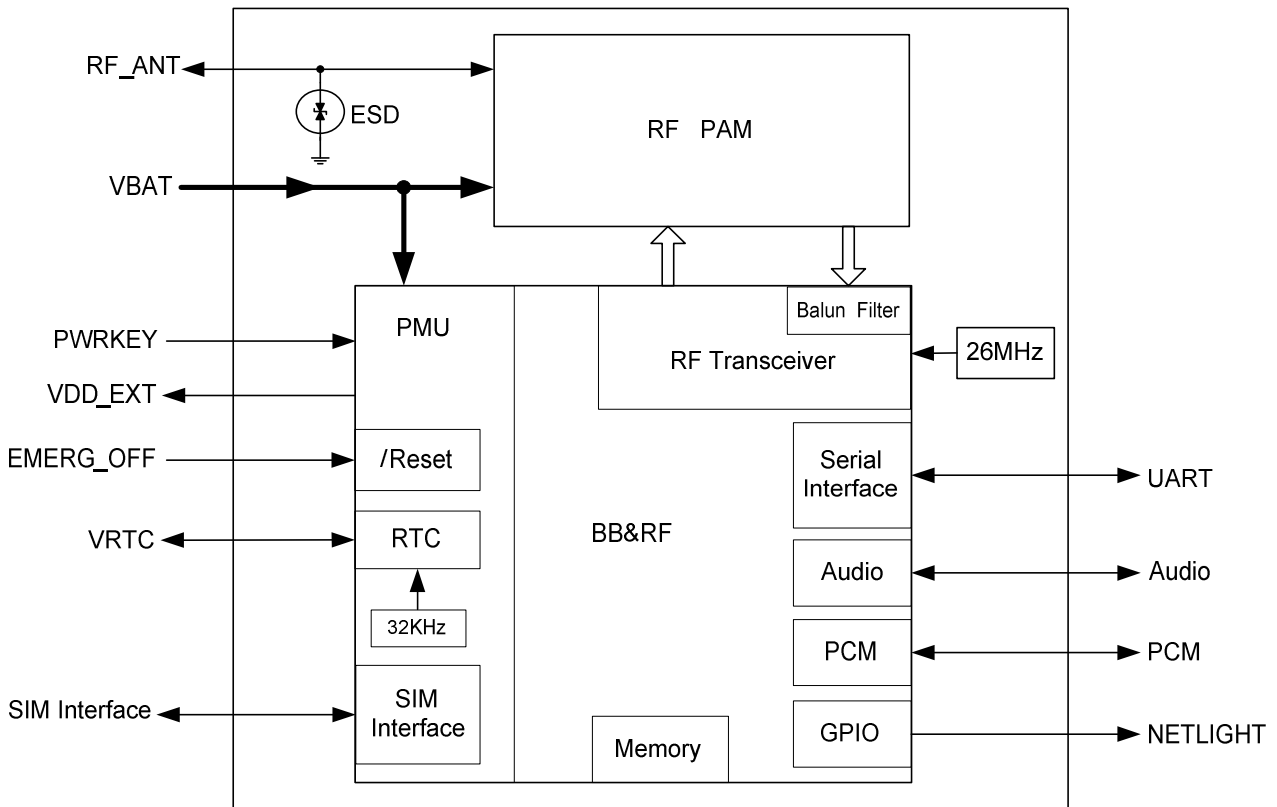

Figure 1: Module Functional Diagram

2.5. Evaluation Board

In order to help you to develop applications with GC65, Quectel supplies an evaluation board (EVB) with RS-232 to USB cable, power adapter, antenna, firmware upgrade cable (UART to USB cable) and other peripherals to control or test the module. For details, please refer to the **document [11]**.

3 Application Interface

The module adopts 44-pin pads with LCC package. The following chapters provide detailed descriptions about these pins below.

- Power supply (*Please refer to chapter 3.3*)
- Power on/down (*Please refer to chapter 3.4*)
- Power saving technology (*Please refer to chapter 3.5*)
- RTC (*Please refer to chapter 3.6*)
- Serial interfaces (*Please refer to chapter 3.7*)
- Audio interfaces (*Please refer to chapter 3.8*)
- SIM interface (*Please refer to chapter 3.9*)
- PCM interface (*Please refer to chapter 3.10*)

3.1. Pin of Module

3.1.1. Pin Assignment

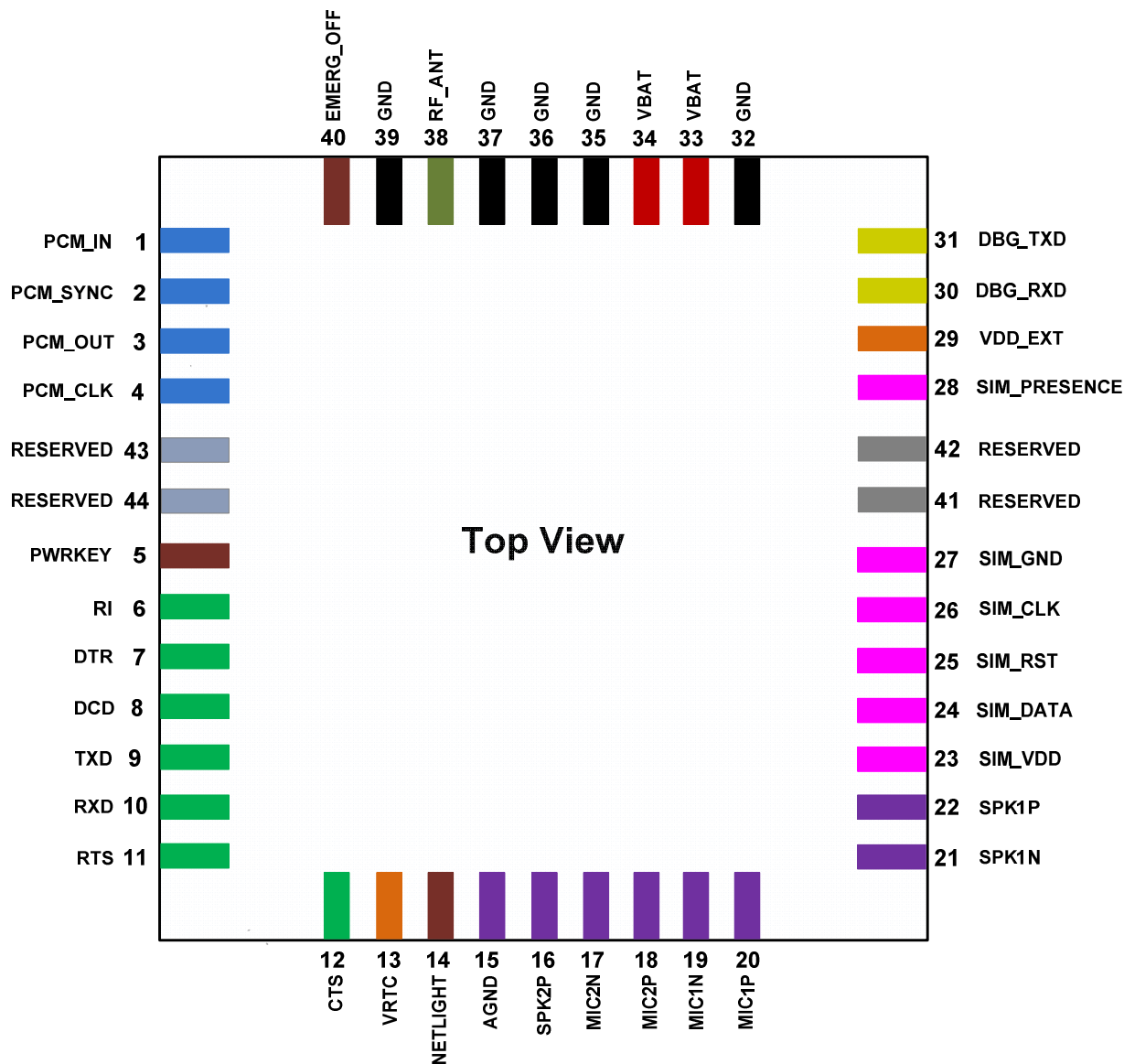

Figure 2: Pin Assignment

3.1.2. Pin Description

Table 3: Pin Description

Power Supply					
Pin Name	Pin NO.	I/O	Description	DC Characteristics	Comment
VBAT	33,34	I	Main power supply of module: VBAT=3.3V~4.6V	Vmax= 4.6V Vmin=3.3V Vnorm=4.0V	Make sure that supply sufficient current in a transmitting burst typically rises to 1.6A.
VRTC	13	I/O	Power supply for RTC when VBAT is not supplied for the system. Charging for backup battery or golden capacitor when the VBAT is applied.	Vlmax=3.3V Vlmin=2.0V Vlnorm=2.8V VOmax=2.9V VOmin=2.7V VOnorm=2.8V Iout(max)=1.35mA Iin=70uA	Recommended to be connected to a backup battery or a golden capacitor. If unused, keep this pin open.
VDD_EXT	29	O	Supply 3.0V voltage for external circuit.	Vmax=3.1V Vmin=2.9V Vnorm=3.0V Imax=20mA	Recommend to add a 2.2 or 4.7uF bypass capacitor, when using this pin for power supply. If unused, keep this pin open.
GND	32,35, 36,37, 39		Ground		
Turn on/off					
Pin Name	Pin NO.	I/O	Description	DC Characteristics	Comment
PWRKEY	5	I	Power on/off key. PWRKEY should be pulled down for a moment to turn on or turn off the system.	VILmax=2.0V VIHmin=2.3V VImax=3.3V	Recommend to add an OC driver circuit to control this pin.
Emergency Shutdown					
Pin Name	Pin NO.	I/O	Description	DC Characteristics	Comment

EMERG_ OFF	40	I	Emergency off. Pulled down for at least 10ms, which will turn off the module in case of emergency. Use it only when shutdown via PWRKEY or AT command cannot be achieved.	VILmax= 0.3×VDD_EXT VIHmin= 0.7×VDD_EXT	Pulled up to VDD_EXT internally. OC/OD driver required in cellular device application. If unused, keep this pin open.
---------------	----	---	---	--	---

Module Indicator

Pin Name	Pin NO.	I/O	Description	DC Characteristics	Comment
NETLIGHT	14	O	Network status indication	VOLmin=0V VOLmax= 0.3×VDD_EXT VOHmin= 0.7×VDD_EXT VOHmax= VDD_EXT	If unused, keep this pin open.

Audio Interfaces

Pin Name	Pin NO.	I/O	Description	DC Characteristics	Comment
MIC1P MIC1N	19,20	I	Channel 1 positive and negative voice input		Main audio channel. Recommended to add ESD protection components at the MIC1P/N lines. If unused, keep these pins open.
SPK1P SPK1N	21,22	O	Channel 1 positive and negative voice output		
MIC2P MIC2N	17,18	I	Channel 2 positive and negative voice input	For Audio DC characteristics refer to Chapter 3.9 .	Auxiliary audio channel. Recommended to add ESD protection components at the MIC2P/N lines. If unused, keep these pins open.
SPK2P	16	O	Channel 2 single-ended voice output		
AGND	15		Audio analog ground.		Separate ground connection for external audio circuits.

UART Port

Pin Name	Pin NO.	I/O	Description	DC Characteristics	Comment
RI	6	O	Ring indication	VILmin=0V VILmax=	
DTR	7	I	Data terminal ready	0.3×VDD_EXT VIHmin=	If only use TXD, RXD and GND to communicate, recommended connecting RTS to GND via a 0R resistor and keeping other pins open.
DCD	8	O	Data carrier detection	0.7×VDD_EXT VIHmax=	
TXD	9	O	Transmit data	VDD_EXT VOLmin=0V	
RXD	10	I	Receive data	VOLmax=	
RTS	11	I	Request to send	0.3×VDD_EXT VOHmin=	
CTS	12	O	Clear to send	0.7×VDD_EXT VOHmax=	
				VDD_EXT	

Debug Port

Pin Name	Pin NO.	I/O	Description	DC Characteristics	Comment
DBG_TXD	31	O	Used for firmware debugging and upgrade. The baud rate is fixed at 921600bps.	VILmin=0V VILmax=	If unused, keep these pins open.
DBG_RXD	30	I		0.3×VDD_EXT VIHmin=	
			0.7×VDD_EXT VIHmax=		
VDD_EXT VOLmin=0V VOLmax=					
				0.3×VDD_EXT VOHmin=	
				0.7×VDD_EXT VOHmax=	
				VDD_EXT	

SIM Interface

Pin Name	Pin NO.	I/O	Description	DC Characteristics	Comment
SIM_VDD	23	O	Power supply for SIM card	The voltage can be selected by software automatically. Either 1.8V or 3V.	All signals of SIM interface should be protected against ESD with a TVS diode

SIM_DATA	24	O	SIM data		array. Maximum trace length is 100mm from the module pad to SIM card holder.
SIM_RST	25	I/O	SIM reset		
SIM_CLK	26	O	SIM clock		
SIM_GND	27		SIM ground		
SIM_PRESENCE	28	I	SIM card detection	VILmin=0V VILmax= 0.3×VDD_EXT VIHmin= 0.7×VDD_EXT VIHmax= VDD_EXT	SIM_PRESENCE must be pulled up by an external resistor when SIM card detection function is used.

PCM Interface

Pin Name	Pin NO.	I/O	Description	DC Characteristics	Comment
PCM_IN	1	I	PCM data input	VILmin=0V VILmax= 0.3×VDD_EXT VIHmin= 0.7×VDD_EXT	PCM function is not supported at present. If unused, keep these pins open.
PCM_SYNC	2	O	PCM frame synchronization	VIHmax= VDD_EXT	
PCM_OUT	3	O	PCM data output	VOLmin=0V VOLmax= 0.3×VDD_EXT VOHmin= 0.7×VDD_EXT	
PCM_CLK	4	O	PCM clock	VOHmax= VDD_EXT	

RF Interface

Pin Name	Pin NO.	I/O	Description	DC Characteristics	Comment
RF_ANT	38	I/O	RF antenna pad	Impedance of 50Ω	Please refer to Chapter 4

Other Interface

Pin Name	Pin NO.	I/O	Description	DC Characteristics	Comment
RESERVED	41,42, 43,44				Please keep these pins open.

3.2. Operating Modes

The table below briefly summarizes the various operating modes in the following chapters.

Table 4: Overview of Operating Modes

Mode	Function
Normal Operation Mode	GSM/GPRS Sleep The module will automatically go into sleep mode if DTR is set to high level and there is no interrupt (such as GPIO interrupt or data on UART port). In this case, the current consumption of module will reduce to the minimal level. During sleep mode, the module can still receive paging message and SMS from the system normally.
	GSM Idle Software is active. The module has registered to the GSM network, and the module is ready to send and receive GSM data.
	GSM Talk GSM connection is ongoing. In this mode, the power consumption is decided by the configuration of Power Control Level (PCL), dynamic DTX control and the working RF band.
	GPRS Idle The module is not registered to GPRS network. The module is not reachable through GPRS channel.
	GPRS Standby The module is registered to GPRS network, but no GPRS PDP context is active. The SGSN knows the Routing Area where the module is located at.
	GPRS Ready The PDP context is active, but no data transfer is ongoing. The module is ready to receive or send GPRS data. The SGSN knows the cell where the module is located at.
	GPRS Data There is GPRS data in transfer. In this mode, power consumption is decided by the PCL, working RF band and GPRS multi-slot configuration.
Power Down Mode	Normal shutdown by sending the “AT+QPOWD=1” command, using the PWRKEY or the EMERG_OFF ¹⁾ pin. The power management ASIC disconnects the power supply from the base band part of the module, and only the power supply for the RTC is remained. Software is not active. The UART interfaces are not accessible. Operating voltage (connected to VBAT) remains applied.
Minimum Functionality Mode	“AT+CFUN” command can set the module to a minimum functionality mode without removing the power supply. In this case, the RF part of the module will not work or the SIM card will not be accessible, or both RF part and SIM card will be disabled, but the UART port is still accessible. The power consumption in this case will be reduced.

NOTE

Use the EMERG_OFF pin only when failing to turn off the module by the command “AT+QPOWD=1” and the PWRKEY pin. For more details, please refer to **Section 3.4.2.4**.

3.3. Power Supply

3.3.1. Power Features of Module

The power supply is one of the key issues in designing GSM terminals. Because of the 577us radio burst in GSM every 4.615 ms, power supply must be able to deliver high current peaks in a burst period. During these peaks, drops on the supply voltage must not exceed minimum working voltage of module.

For GC65 module, the max current consumption could reach to 1.6A during a transmit burst. It will cause a large voltage drop on the VBAT. In order to ensure stable operation of the module, it is recommended that the max voltage drop during the transmit burst does not exceed 400mV.

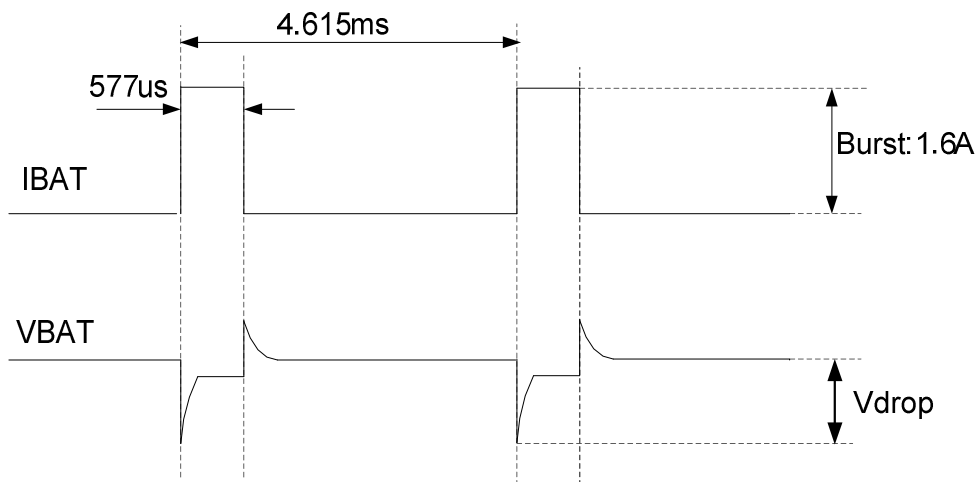

Figure 3: Voltage Drop during Transmitting

3.3.2. Decrease Supply Voltage Drop

The power supply range of the module is 3.3V to 4.6V. Make sure that the input voltage will never drop below 3.3V even in a transmitting burst. If the power voltage drops below 3.3V, the module could turn off automatically. For better power performance, it is recommended to place a 1000uF tantalum capacitor with low ESR and ceramic capacitor 100nF, 47pF and 27pF near the VBAT pin. The reference circuit is illustrated in Figure 4.

The VBAT route should be wide enough to ensure that there is not too much voltage drop during transmit burst. The width of trace should be no less than 2mm and the principle of the VBAT route is the longer route, the wider trace.

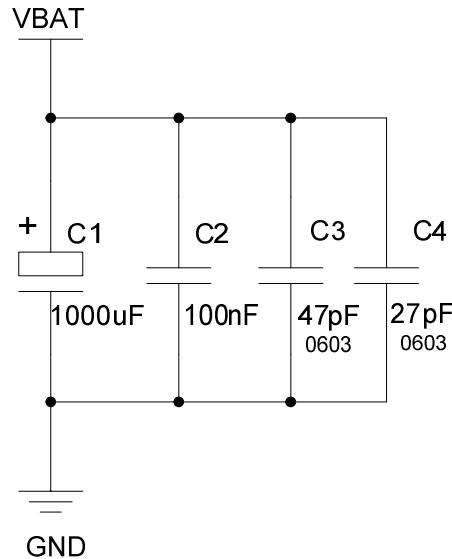

Figure 4: Reference Circuit for the VBAT Input

3.3.3. Reference Design for Power Supply

The power design for the module is very important, since the performance of power supply for the module largely depends on the power source. The power supply is capable of providing the sufficient current to 2A at least. If the voltage drop between the input and output is not too high, it is suggested to use a LDO as module's power supply. If there is a big voltage difference between the input source and the desired output (VBAT), a switching power converter is recommended to be used as a power supply.

Figure 5 shows a reference design for +5V input power source. The designed output for the power supply is 4.16V and the maximum load current is 3A. In addition, in order to get a stable output voltage, a zener diode is placed close to the pins of VBAT. As to the zener diode, it is suggested to use a zener diode whose reverse zener voltage is 5.1V and dissipation power is more than 1 Watt.

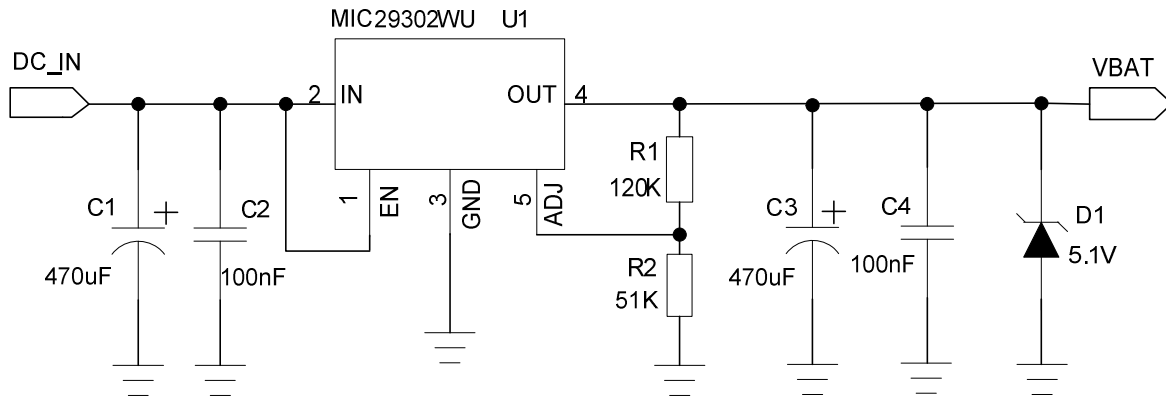

Figure 5: Reference Circuit for Power Supply

If a switching power converter is used, please follow the diagram to design the circuit, it is beneficial to maintain stable power supply for the module.

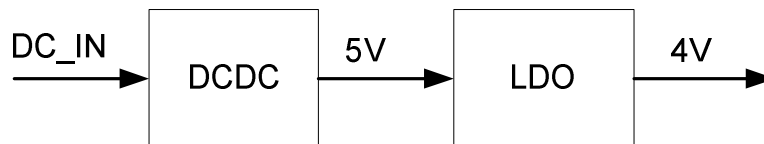

Figure 6: Reference Diagram for Switching Power Converter

3.3.4. Monitor Power Supply

To monitor the supply voltage, you can use the “AT+CBC” command which includes three parameters: charging status, remaining battery capacity and voltage value (in mV). It returns the 0-100 percent of battery capacity and actual value measured between VBAT and GND. The voltage is automatically measured in period of 5s. The displayed voltage (in mV) is averaged over the last measuring period before the “AT+CBC” command is executed.

For details, please refer to [document \[1\]](#).

3.4. Power On and Down Scenarios

3.4.1. Power On

The module can be turned on by driving the pin PWRKEY to a low level voltage, after booting successfully, PWRKEY pin can be released. You may monitor the status of the NETLIGHT pin to judge whether the module is power-on or not. When NETLIGHT pin outputs a signal with certain frequency, it indicates the module is turned on successfully. The NETLIGHT pin will keep in low level all the time after the module is

turned off. An OC driver circuit is suggested to control the PWRKEY. A simple reference circuit is illustrated as below:

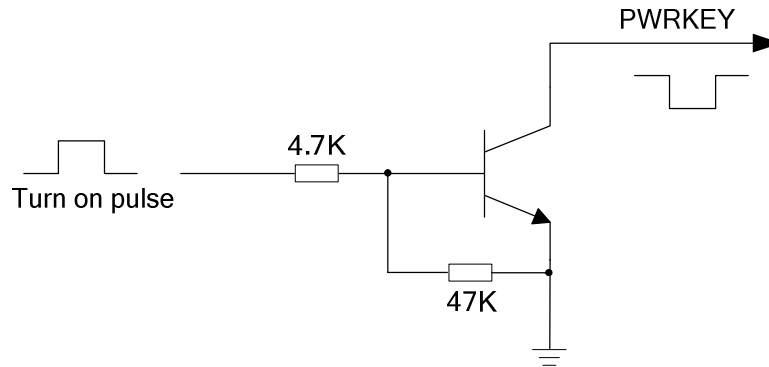

Figure 7: Turn On the Module with an OC Driver

NOTE

GC65 module is set to autobauding mode (AT+IPR=0) by default. In the autobauding mode, URC "RDY" is not reported to the host controller after module is powered on. When the module receives AT command, it will be powered on after a delay of 5~6 seconds. Host controller should first send the "AT" string in order that the module can detect baud rate of host controller, and it will continuously send 1~5 "AT" string until receiving "OK" string from the module. Then enter "AT+IPR=x;&W" to set a fixed baud rate for the module and save the configuration to flash memory of the module. After these configurations, the URC "RDY" would be received from the UART port of the module every time when the module is powered on. For more details, refer to the section "AT+IPR" in **document [1]**.

The other way to control the PWRKEY is through a button directly. A TVS component is indispensable to be placed nearby the button for ESD protection. For the best performance, the TVS component must be placed nearby the button. When pressing the key, electrostatic strike may generate from finger. A reference circuit is shown in the following figure:

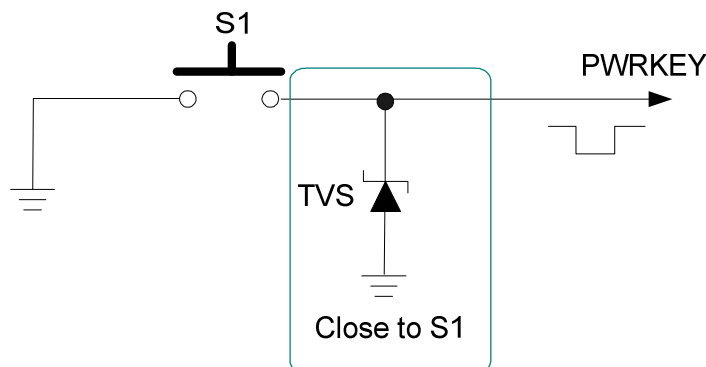

Figure 8: Turn On the Module with a Button

The turn-on timing is illustrated as the following figure:

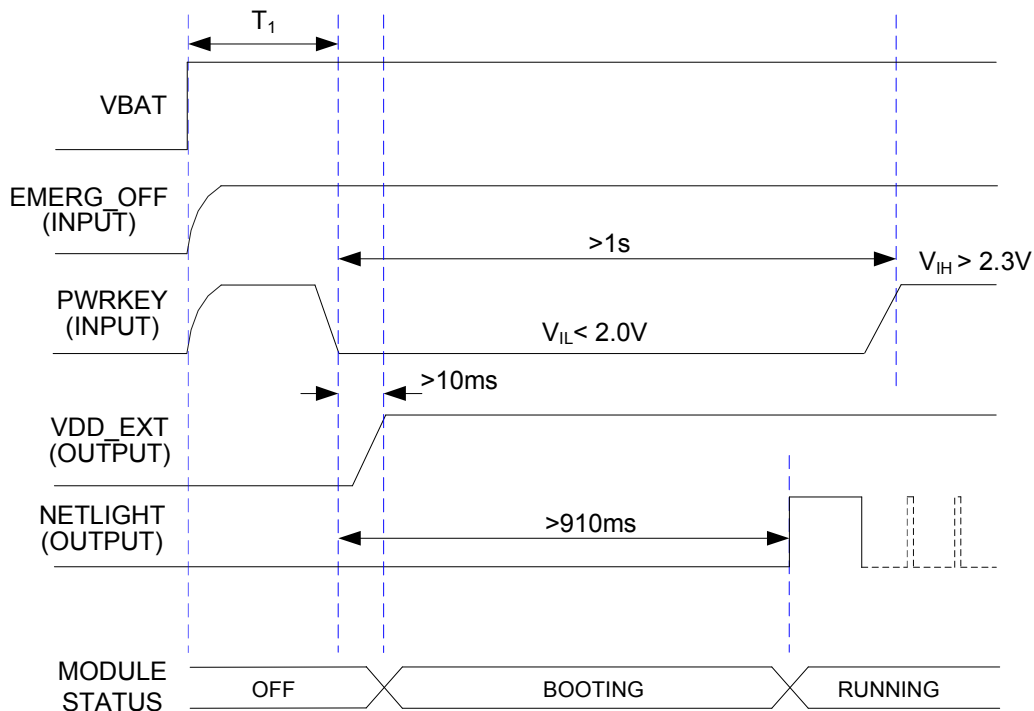

Figure 9: Turn-on Timing

NOTES

1. Make sure that VBAT is stable before pulling down PWRKEY pin. At least 30ms for T_1 is recommended.
2. EMERG_OFF should be floated when it is unused.

You can monitor the status of the NETLIGHT pin to judge whether the module is power-on. After the NETLIGHT pin goes to pulse, PWRKEY can be released. If the NETLIGHT pin is ignored, pull the PWRKEY pin to low level for more than 2 seconds to turn on the module.

3.4.2. Power Down

The following procedures can be used to turn off the module:

- Normal power down procedure: Turn off module by the PWRKEY pin.
- Normal power down procedure: Turn off module by command "AT+QPOWD".
- Over-voltage or under-voltage automatic shutdown: Take effect when over-voltage or under-voltage is detected.
- Emergent power down procedure: Turn off module by the EMERG_OFF pin.

After power down, no further AT commands can be executed, only the RTC is still active. The power down mode can be indicated by the VDD_EXT pin (the NETLIGHT pin can also be used.), which is a low level voltage in this mode.

3.4.2.1. Power Down Module by the PWRKEY Pin

It is a safe way to turn off the module by driving the PWRKEY to a low level voltage for a certain time. The power down scenario is illustrated in Figure 10:

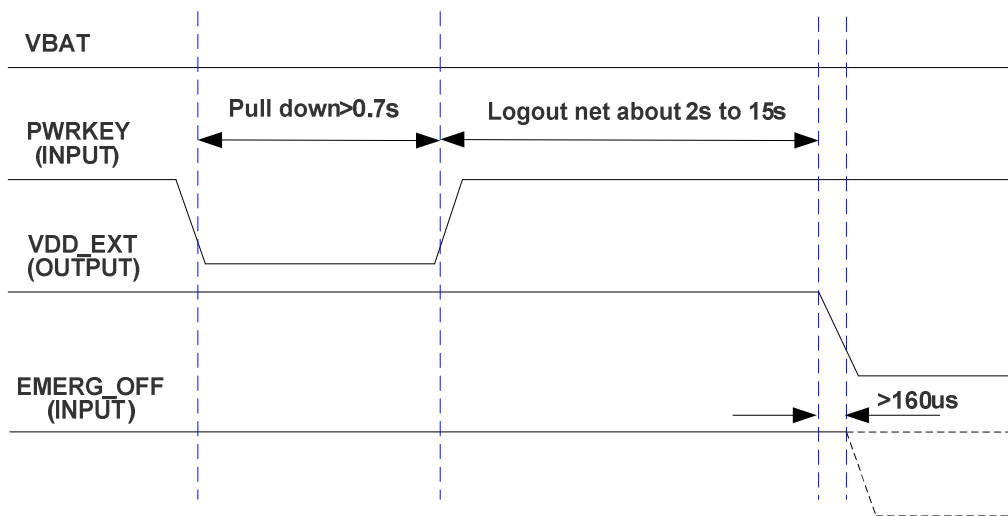

Figure 10: Turn-off Timing

The power down procedure causes the module to log off from the network and allows the firmware to save important data before completely disconnecting the power supply.

Before the completion of the power down procedure, the module sends the result code, shown as below:

NORMAL POWER DOWN

NOTE

When autobauding is active and DTE&DCE are not correctly synchronized after start-up, this result code will not appear. It is recommended to set a fixed baud rate for the module.

3.4.2.2. Power Down Module by AT Command

It is also a safe way to turn off the module via AT command "AT+QPOWD=1". This command will let the module log off from the network and allow the firmware to save important data before completely disconnecting the power supply.

Before the completion of the power down procedure, the module sends the result code, shown as below:

NORMAL POWER DOWN

Please refer to the **document [1]** for details about the AT command "**AT+QPOWD**".

3.4.2.3. Over-voltage or Under-voltage Automatic Shutdown

The module will constantly monitor the voltage applied on the VBAT, if the voltage is $\leq 3.5V$, the following URC will be presented:

UNDER_VOLTAGE WARNING

If the voltage is $\geq 4.5V$, the following URC will be presented:

OVER_VOLTAGE WARNING

The normal input voltage range is from 3.3V to 4.6V. If the voltage is $> 4.6V$ or $< 3.3V$, the module would automatically shut down itself.

If the voltage is $< 3.3V$, the following URC will be presented:

UNDER_VOLTAGE POWER DOWN

If the voltage is $> 4.6V$, the following URC will be presented:

OVER_VOLTAGE POWER DOWN

NOTE

When autobauding is active and DTE&DCE are not correctly synchronized after start-up, this result code will not appear. It is recommended to set a fixed baud rate for the module.

3.4.2.4. Emergency Shutdown by EMERG_OFF Pin

The module can be shut down by driving the pin EMERG_OFF to a low level voltage over 10ms and then releasing it. The EMERG_OFF line can be driven by an OC/OD driver or a button. The circuit is illustrated as the following figures:

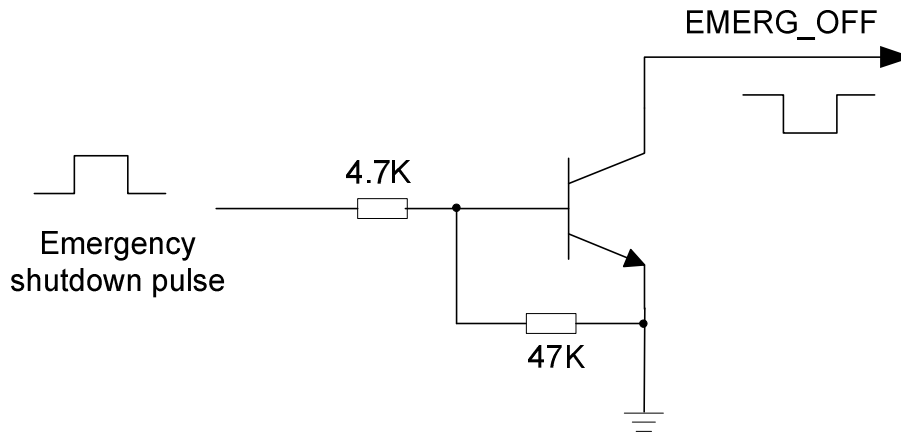

Figure 11: An OC Driver for EMERG_OFF

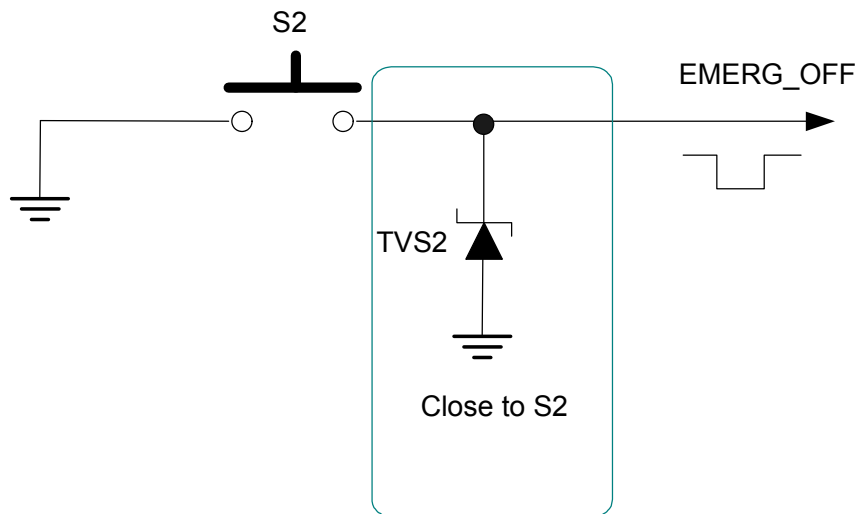

Figure 12: Reference Circuit for EMERG_OFF by Button

Be cautious to use the pin EMERG_OFF. It should only be used under emergent situation. For instance, if the module is unresponsive or abnormal, the pin EMERG_OFF could be used to shut down the system. Although turning off the module by EMERG_OFF is fully tested and no error is detected, this operation is still a big risk as it could cause to destroy the code or data area of the flash memory in the module. Therefore, it is recommended that PWRKEY or AT command should always be the preferential way to turn off the system.

3.4.3. Restart

You can restart the module by driving the PWRKEY to a low level voltage for a certain time, which is similar to the way of turning on module. Before restarting the module, at least 500ms should be delayed after detecting the low level of VDD_EXT. The restart timing is illustrated as the following figure:

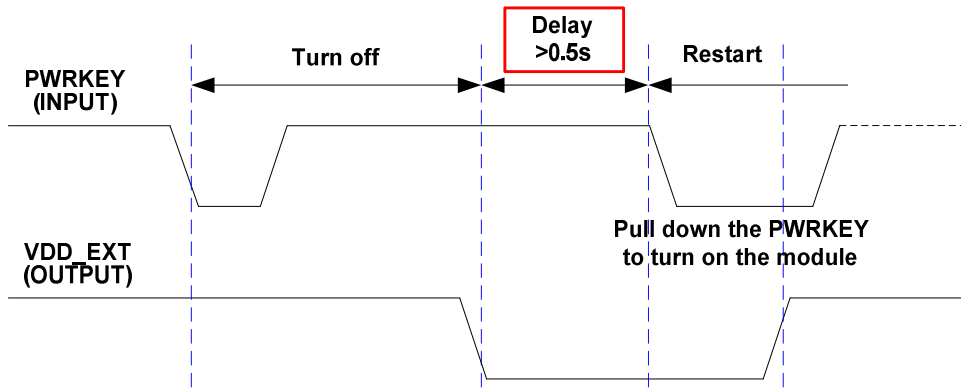

Figure 13: Timing of Restarting System

The module can also be restarted by the PWRKEY after emergency shutdown.

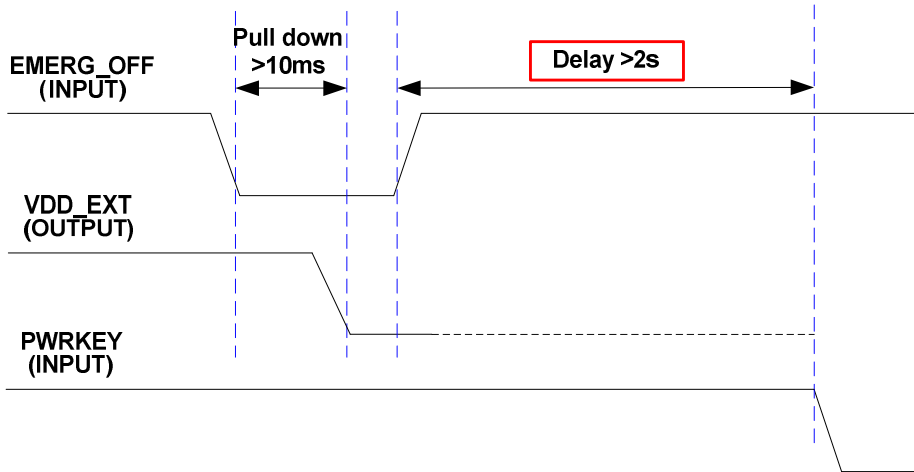

Figure 14: Timing of Restarting System after Emergency Shutdown

NOTE

Before pulling down the EMERG_OFF pin, please ensure that the PWRKEY pin has been released.

3.5. Power Saving Technology

Based on system requirements, there are several actions to drive the module to enter into low current consumption state. For example, “AT+CFUN” can be used to set module into minimum functionality mode and DTR hardware interface signal can be used to lead system to sleep mode.

3.5.1. Minimum Functionality Mode

Minimum functionality mode reduces the functionality of the module to a minimum level. The consumption of the current can be minimized when the slow clocking mode is activated at the same time. The mode is set with the “AT+CFUN” command which provides the choice of the functionality levels <fun>=0,1,4.

- 0: Minimum functionality.
- 1: Full functionality (default).
- 4: Disable both transmitting and receiving of RF part.

If the module is set to minimum functionality by “AT+CFUN=0”, the RF function and SIM card function would be disabled. In this case, the UART port is still accessible, but all AT commands related with RF function or SIM card function will not be available.

If the module has been set by the command with “AT+CFUN=4”, the RF function will be disabled, but the UART port is still active. In this case, all AT commands related with RF function will not be available.

After the module is set by “AT+CFUN=0” or “AT+CFUN=4”, it can return to full functionality by “AT+CFUN=1”.

For detailed information about “AT+CFUN”, please refer to the **document [1]**.

3.5.2. Sleep Mode

The sleep mode is disabled by default. You can enable it by “AT+QSCLK=1”. On the other hand, the default setting is “AT+QSCLK=0” and in this mode, the module cannot enter into sleep mode.

When the module is set by the command “AT+QSCLK=1”, you can control the module to enter into or exit from the sleep mode through pin DTR. When DTR is set to high level, and there is no on-air or hardware interrupt such as GPIO interrupt or data on UART port, the module will enter into sleep mode automatically. In this mode, the module can still receive voice, SMS or GPRS paging from network, but the UART port does not work.

3.5.3. Wake Up Module from Sleep Mode

When the module is in the sleep mode, the following methods can wake up the module:

- If the DTR pin is set to low level, it would wake up the module from the sleep mode.
- Receive a voice or GPRS data from network to wake up module.
- Receive an SMS from network to wake up module.

NOTE

DTR pin should be kept in low level during communication between the module and DTE.

3.5.4. Summary of State Transition

Table 5: Summary of State Transition

Current Mode	Next Mode		
	Power Down	Normal Mode	Sleep Mode
Power Down		Use PWRKEY	
Normal Mode	AT+QPOWD, use PWRKEY pin, or use EMERG_OFF pin		Use AT command “AT+QSCLK=1” and pull up DTR
Sleep Mode	Use PWRKEY pin, or use EMERG_OFF pin	Pull down DTR or incoming voice call or SMS or GPRS data	

3.6. RTC Backup

The RTC (Real Time Clock) can be supplied by an external capacitor or battery (rechargeable or non-chargeable) through the pin VRTC. A 2.2K resistor has been integrated in the module for current limiting. A coin-cell battery or a super-cap can be used to backup power supply for RTC.

The following figures show various sample circuits for RTC backup.

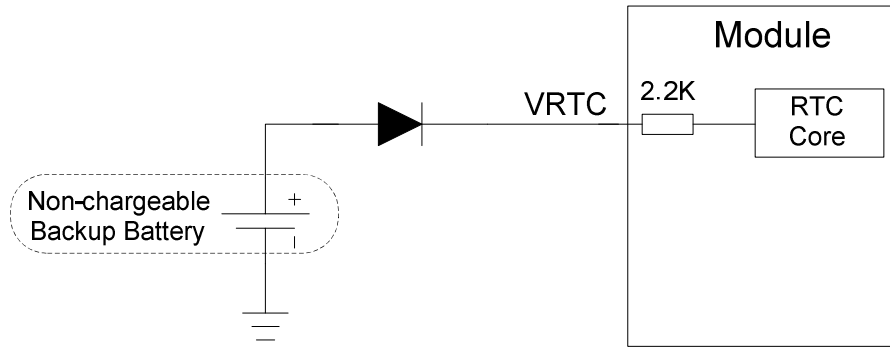

Figure 15: RTC Supplied from a Non-chargeable Battery

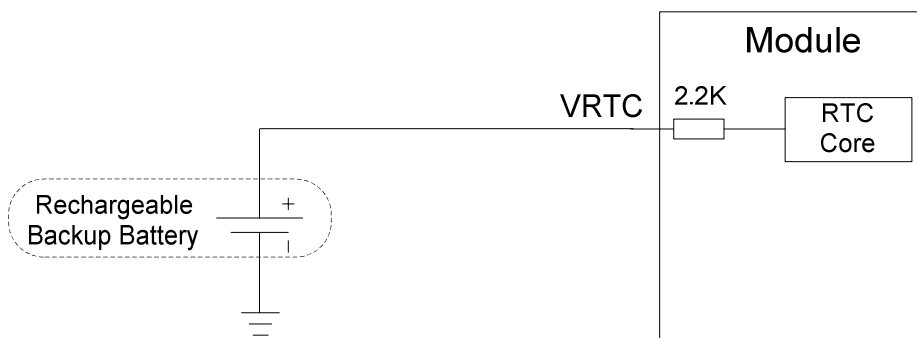

Figure 16: RTC Supplied from a Rechargeable Battery

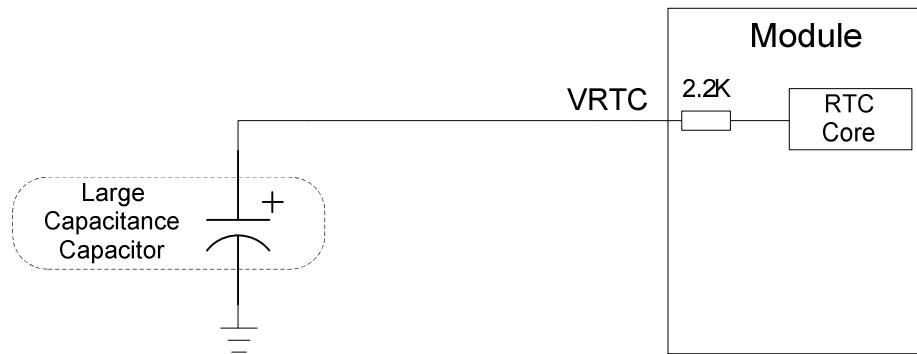

Figure 17: RTC Supplied from a Capacitor

The following figure shows the charging characteristics of a coin-type rechargeable battery XH414H-IV01E from Seiko.

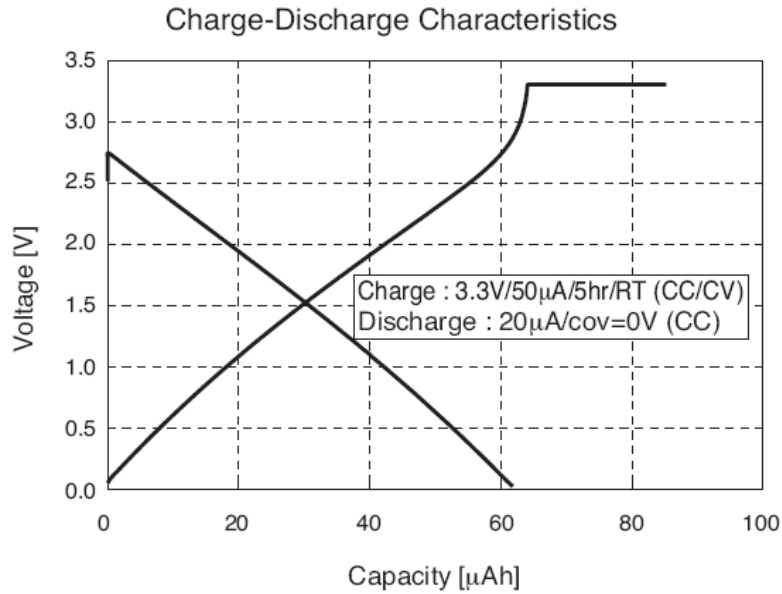

Figure 18: Charging Characteristics of Seiko's XH414H-IV01E

3.7. Serial Interfaces

The module provides two universal asynchronous serial ports: UART port and debug port. The module is designed as a DCE (Data Communication Equipment), following the traditional DCE-DTE (Data Terminal Equipment) connection. Autobauding function supports baud rate from 4800bps to 115200bps.

The UART port:

- TXD: Send data to RXD of DTE.
- RXD: Receive data from TXD of DTE.
- RTS: Request to send.
- CTS: Clear to send.
- DTR: DTE is ready and inform DCE (this pin can wake the module up).
- RI: Ring indicator (when the call, SMS, data of the module are coming, the module will output signal to inform DTE).
- DCD: Data carrier detection (the validity of this pin demonstrates the communication link is set up).

NOTE

The module disables hardware flow control by default. When hardware flow control is required, RTS and CTS should be connected to the host. AT command "AT+IFC=2,2" is used to enable hardware flow control. AT command "AT+IFC=0,0" is used to disable the hardware flow control. For more details, please refer to the **document [1]**.

The Debug port:

- DBG_TXD: Send data to the COM port of computer.
- DBG_RXD: Receive data from the COM port of computer.

The logic levels are described in the following table:

Table 6: Logic Levels of the UART Interfaces

Parameter	Min.	Max.	Unit
V_{IL}	0	$0.3 \times VDD_EXT$	V
V_{IH}	$0.7 \times VDD_EXT$	VDD_EXT	V
V_{OL}	0	$0.3 \times VDD_EXT$	V
V_{OH}	$0.7 \times VDD_EXT$	VDD_EXT	V

Table 7: Pin Definition of the UART Interfaces

Interfaces	Pin Name	Pin NO.	Description
UART Port	TXD	9	Transmit data
	RXD	10	Receive data
	RTS	11	Request to send
	CTS	12	Clear to send
	DTR	7	Data terminal ready
	DCD	8	Data carrier detection
	RI	6	Ring indication
Debug Port	DBG_TXD	31	Transmit data
	DBG_RXD	30	Receive data

3.7.1. UART Port

3.7.1.1. The Features of UART Port

- Seven lines on UART interface.
- Contain data lines as TXD and RXD, hardware flow control lines as RTS and CTS, other control lines as DTR, DCD and RI.
- Used for AT command, GPRS data, etc.
- Support the following communication baud rates: 2400, 4800, 9600, 14400, 19200, 28800, 38400, 57600, 115200, 230400 and 460800bps.
- The default setting is autobauding mode. Support the following baud rates for autobauding function: 4800, 9600, 19200, 38400, 57600 and 115200bps.
- The module disables hardware flow control by default. AT command "AT+IFC=2,2" is used to enable hardware flow control.

After setting a fixed baud rate or autobauding, please send "AT" string at that rate. The UART port is ready when it responds "OK".

Autobauding allows the module to detect the baud rate by receiving the string "AT" from the host or PC automatically, which gives module flexibility without considering which baud rate is used by the host controller. Autobauding is enabled by default. To take advantage of the autobauding mode, special attention should be paid according to the following requirements:

1. Synchronization between DTE and DCE

When DCE (the module) powers on with the autobauding enabled, it is recommended to wait 5~6 seconds before sending the first "AT" characters. After receiving the "OK" response, DTE and DCE are correctly synchronized.

If the host controller needs URC in the mode of autobauding, it must be synchronized firstly. Otherwise the URC will be discarded.

2. Restrictions on autobauding operation

- The UART port has to be operated at 8 data bits, no parity and 1 stop bit (factory setting).
- The Unsolicited Result Codes like "RDY", "+CFUN: 1" and "+CPIN: READY" will not be indicated when the module is turned on with autobauding enabled and not be synchronized.
- Any other unsolicited result codes will be sent at the previous baud rate before the module detects the new baud rate by receiving the "AT" string. The DTE may receive unknown characters after switching to new baud rate.
- It is not recommended to switch to autobauding from a fixed baud rate.

NOTE

To ensure reliable communication and avoid any problems caused by undetermined baud rate between DCE and DTE, it is strongly recommended to configure a fixed baud rate and save it instead of using autobauding after start-up. For more details, please refer to the section “*AT+IPR*” in *document [1]*.

3.7.1.2. The Connection of UART

The connection between module and host by UART port is very flexible. Three connection styles are illustrated as below.

Reference design for Full-Function UART connection is shown as below when it is applied in modulation-demodulation.

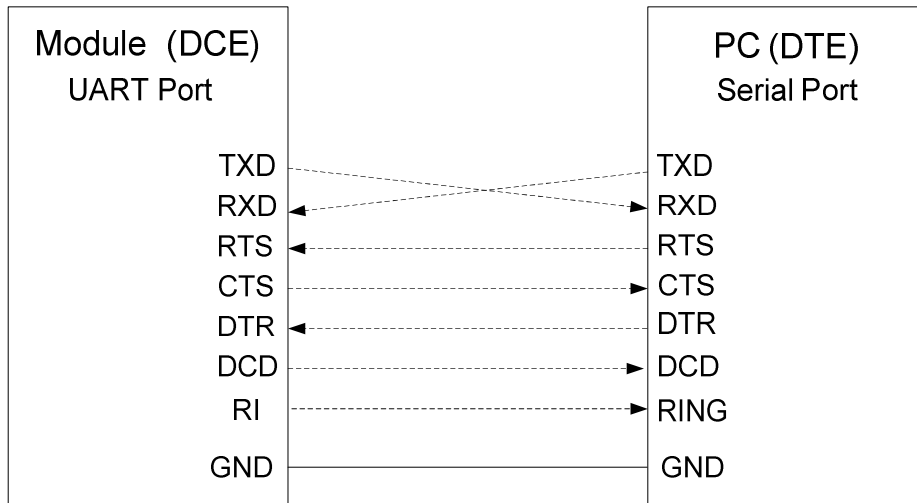

Figure 19: Reference Design for Full-Function UART

Three-line connection is shown as below:

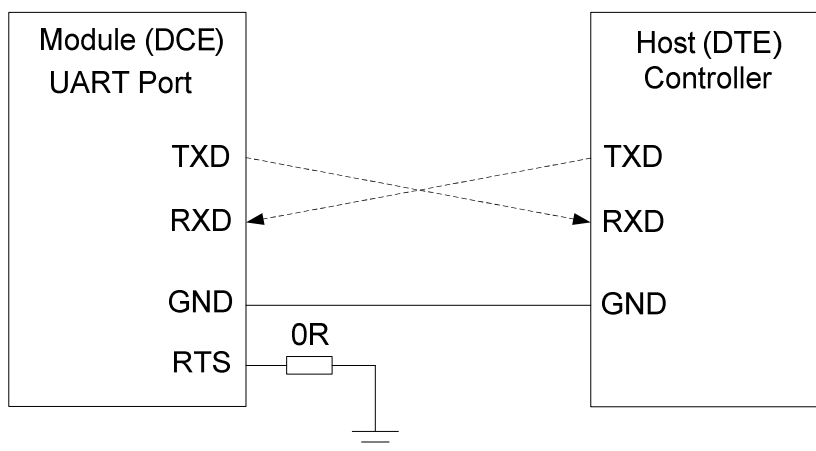

Figure 20: Reference Design for UART Port

UART port with hardware flow control is shown as below. This connection will enhance the reliability of the mass data communication.

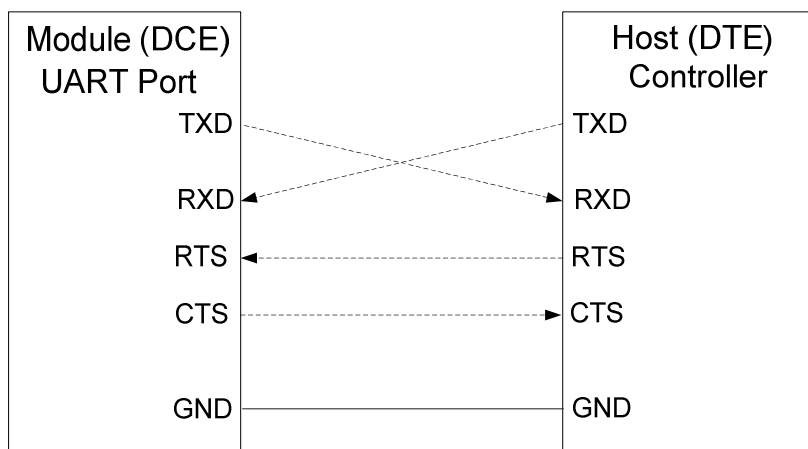

Figure 21: Reference Design for UART Port with Hardware Flow Control

3.7.2. Debug and Upgrade Port

Debug port:

- Two lines: DBG_TXD and DBG_RXD
- Debug port is used for firmware debugging and upgrading, its baud rate must be configured as 921600bps.

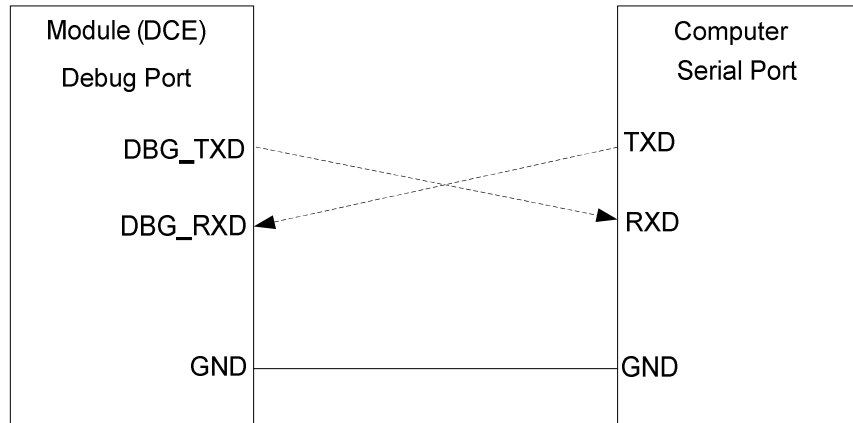

Figure 22: The Connection of Firmware Debugging and Upgrade

NOTE

Because the debug port uses a high baud rate 921600bps configuration, when connecting a PC for debugging and upgrading, the UART to USB mode is recommended. The test points for debug UART is recommended to be reserved, for detailed design, please refer to the **document [12]**.

3.7.3. UART Application

VDD_EXT is the reference voltage level for UART of GC65, the 1K resistors is recommended to be added on the UART lines, the reference circuit is shown as below. This circuit is also applicable in 2.8V or 3.0V systems.

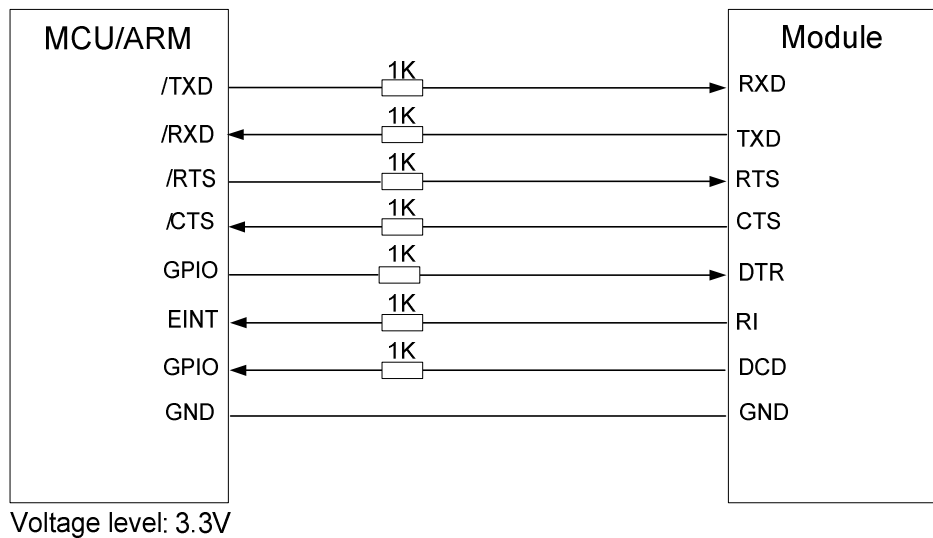

Figure 23: Level Match Design for 3.3V System

The reference design for 5V level match is shown as below. The connection of dotted line can be referred to the connection of solid line. Please pay attention to the direction of signal. Input dotted line of module should be referred to input solid line of the module. Output dotted line of module should be referred to output solid line of the module.

As to the circuit below, VDD_EXT supplies power for the I/O of module, while VCC_MCU supplies power for the I/O of the peripheral.

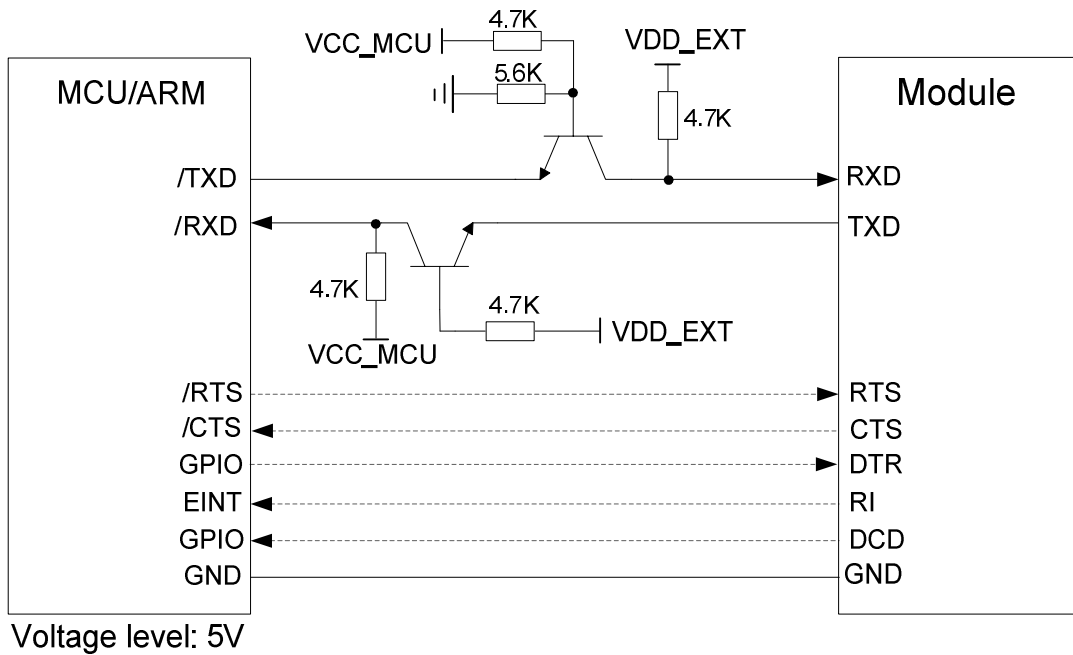

Figure 24: Level Match Design for 5V System

The following circuit shows a reference design for the communication between module and PC. A RS232 level shifter IC or circuit must be inserted between module and PC, since the UART port does not support the RS232 level, but the CMOS level only.

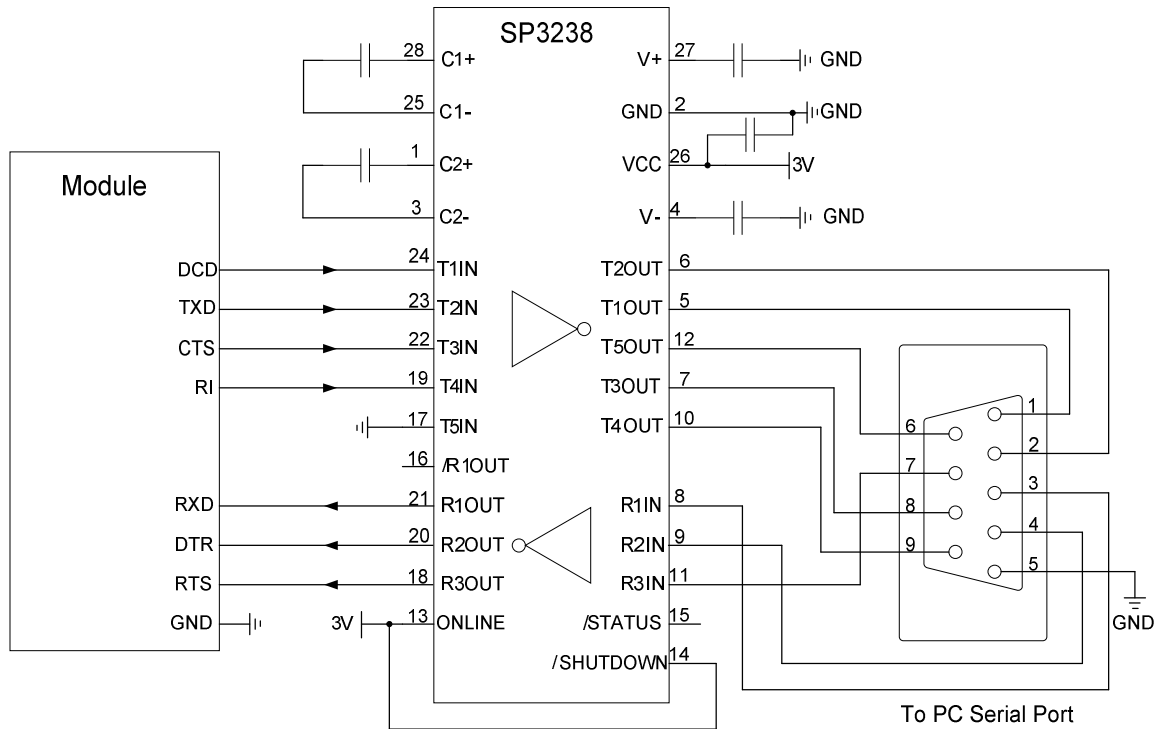

Figure 25: Level Match Design for RS-232

NOTE

For three-line UART port, the UART to USB mode can also be used.

3.8. Audio Interfaces

The module provides two analog audio input channels and two analog audio output channels.

Table 8: Pin Definition of Audio Interface

Interfaces	Pin Name	Pin NO.	Description
AIN1/AOUT1	MIC1P	20	Channel 1 microphone positive input
	MIC1N	19	Channel 1 microphone negative input

	SPK1P	22	Channel 1 audio positive output
	SPK1N	21	Channel 1 audio negative output
	MIC2P	18	Channel 2 microphone positive input
	MIC2N	17	Channel 2 microphone negative input
AIN2/AOUT2	SPK2P	16	Channel 2 audio single-ended output
	AGND	15	Form a pseudo-differential pair with SPK2P

AIN1 and AIN2 can be used for input of microphone. An electret microphone is usually used. AIN1 and AIN2 are both differential input channels.

AOUT1 is used for output of the receiver. This channel is typically used for a receiver built into a handset. AOUT1 channel is a differential channel. If it is used as a speaker, an amplifier should be employed.

AOUT2 is used for output of earphone, which can be used as a single-ended channel. SPK2P and AGND can establish a pseudo differential mode.

All of these two audio channels support voice and ringtone output, and so on, and can be switched by “AT+QAUDCH” command. For more details, please refer to the **document [1]**.

Use AT command “AT+QAUDCH” to select audio channel:

- 0--AIN1/AOUT1 (main audio channel), the default value is 0.
- 1--AIN2/AOUT2 (auxiliary audio channel), this channel is used for earphone.

For each channel, you can use AT+QMIC to adjust the input gain level of microphone. You can also use “AT+CLVL” to adjust the output gain level of receiver. “AT+QSIDET” is used to set the side-tone gain level. For more details, please refer to the **document [1]**.

3.8.1. Decrease TDD Noise and Other Noises

The 47pF capacitor is applied for filtering out 900MHz RF interference when the module is transmitting at GSM900MHz. Without placing this capacitor, TDD noise could be heard. Moreover, the 10pF capacitor here is for filtering out 1800MHz RF interference. However, the resonant frequency point of a capacitor largely depends on the material and production technique. Therefore, you would have to discuss with its capacitor vendor to choose the most suitable capacitor for filtering out GSM850MHz, GSM900MHz, DCS1800MHz and PCS1900MHz separately.

The severity degree of the RF interference in the voice channel during GSM transmitting period largely depends on the application design. In some cases, GSM900 TDD noise is more severe; while in other

cases, DCS1800 TDD noise is more obvious. Therefore, you can have a choice based on test results. Sometimes, even no RF filtering capacitor is required.

The capacitor which is used for filtering out RF noise should be close to audio interface. Audio alignment should be as short as possible.

In order to decrease radio or other signal interference, the position of RF antenna should be kept away from audio interface and audio alignment. Power alignment and audio alignment should not be parallel, and power alignment should be far away from audio alignment.

The differential audio traces have to be placed according to the differential signal layout rule.

3.8.2. Microphone Interfaces Design

AIN1 and AIN2 channels come with internal bias supply for external electret microphone. A reference circuit is shown in the following figure.

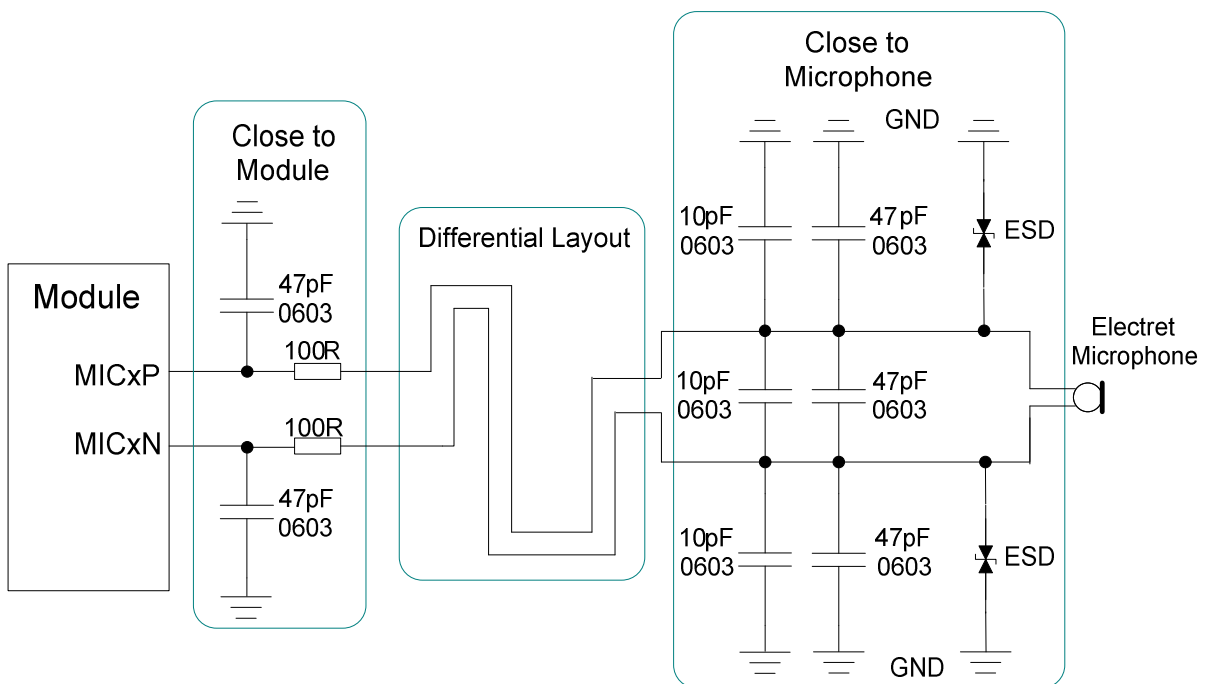

Figure 26: Reference Design for AIN1&AIN2

NOTE

The ESD protection components on the MIC channels are strongly recommended.

3.8.3. Receiver Interface Design

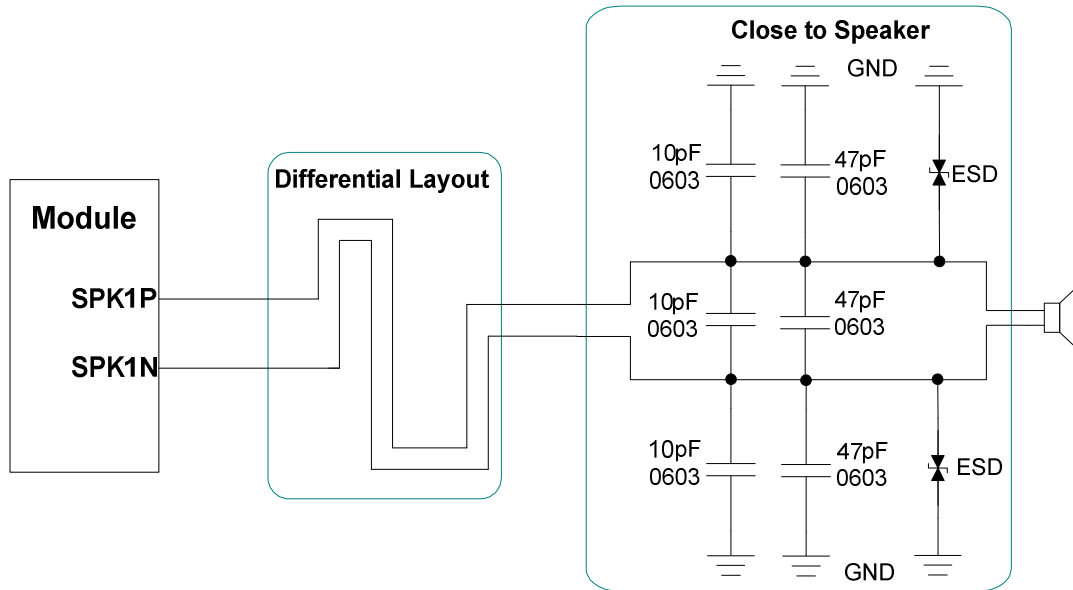

Figure 27: Reference Receiver Interface Design of AOUT1

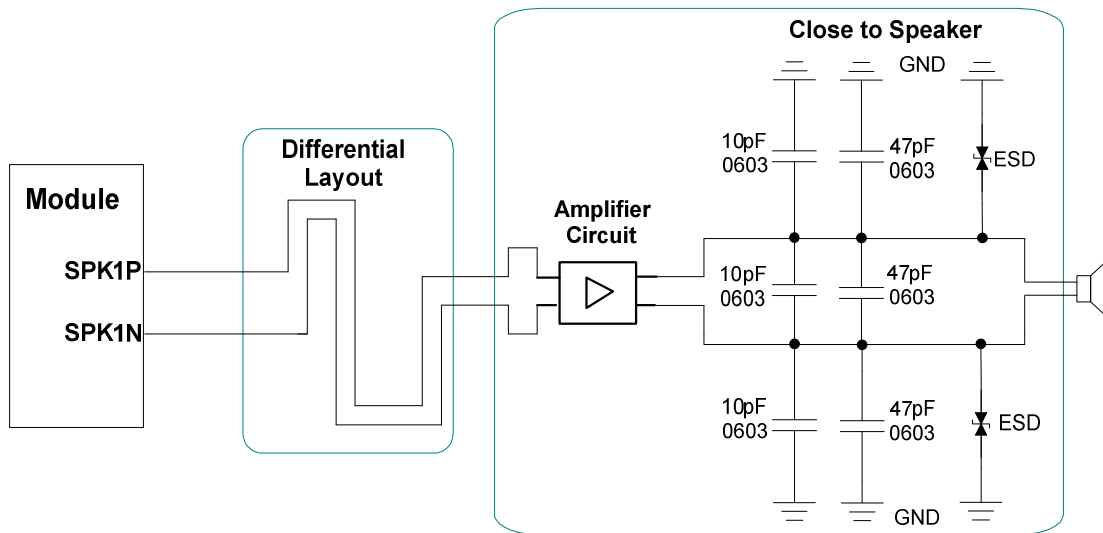

Figure 28: Speaker Interface with Amplifier Configuration of AOUT1

Texas Instruments TPA6205A1 is recommended for a suitable differential audio amplifier. There are plenty of excellent audio amplifiers in the market.

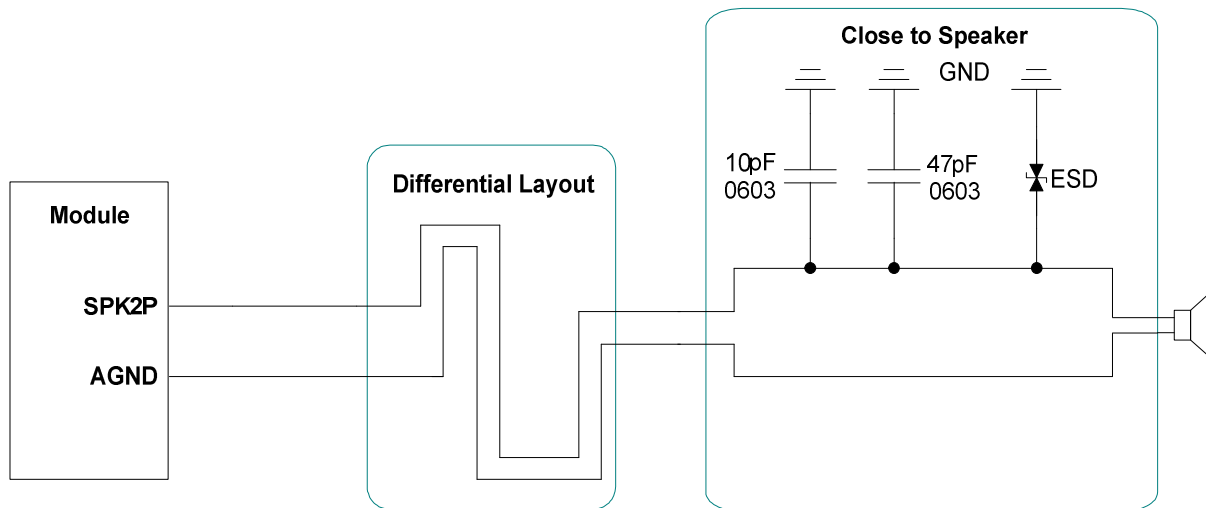

Figure 29: Reference Receiver Interface Design of AOUT2

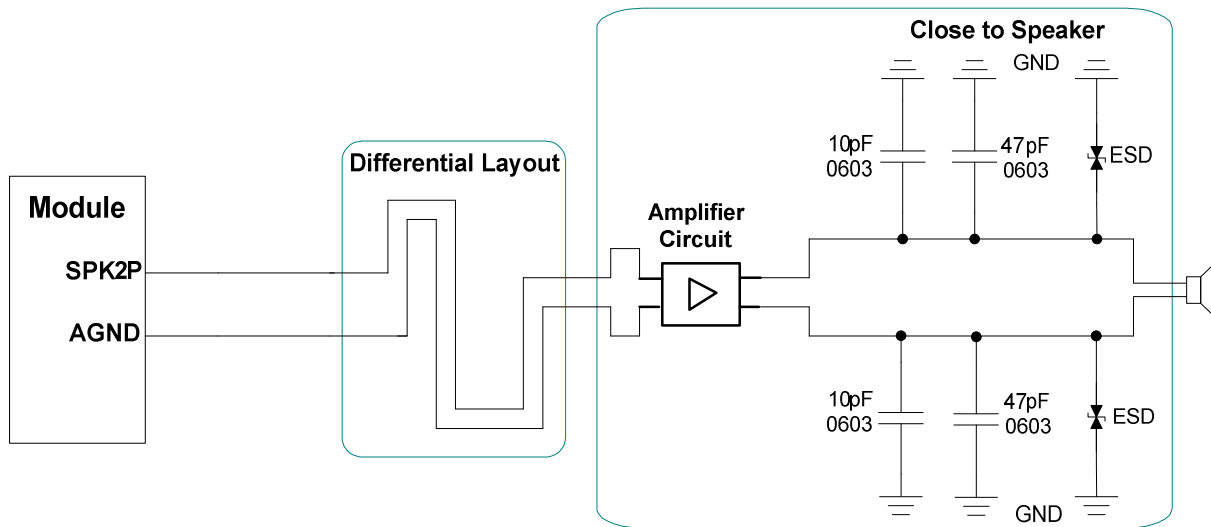

Figure 30: Speaker Interface with Amplifier Configuration of AOUT2

3.8.4. Earphone Interface Design

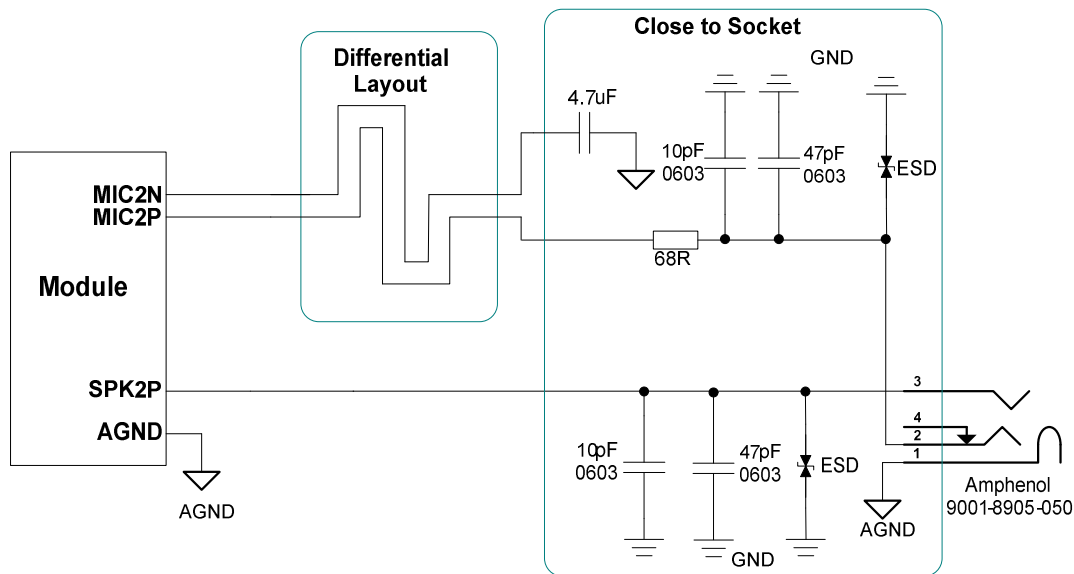

Figure 31: Earphone Interface Design

3.8.5. Audio Characteristics

Table 9: Typical Electret Microphone Characteristics

Parameter	Min.	Typ.	Max.	Unit
Working Voltage	1.2	1.5	2.0	V
Working Current	200		500	uA
External Microphone Load Resistance		2.2		kΩ

Table 10: Typical Audio Output Characteristics

Parameter	Min.	Typ.	Max.	Unit
AOUT1 (SPK1)	Single-ended	Load resistance	16	Ω
		Ref level	0	Vpp
	Differential	Load resistance	16	Ω
		Ref level	0	2.6

AOUT2 (SPK2)	Single-ended	Load resistance	32	Ω
		Reference level	0	1.0 Vpp
Maximum Driving Current Limit of SPK1 and SPK2		SPK1	80	mA
		SPK2	25	mA

3.9. SIM Card Interface

3.9.1. SIM Card Application

The SIM interface supports the functionality of the GSM Phase 1 specification and also supports the functionality of the new GSM Phase 2+ specification for FAST 64 kbps SIM card, which is intended to use with a SIM application Tool-kit.

The SIM interface is powered by an internal regulator in the module. Both 1.8V and 3.0V SIM Cards are supported.

Table 11: Pin Definition of the SIM Interface

Pin Name	Pin NO.	Description
23	SIM_VDD	Supply power for SIM card. Automatic detection of SIM card voltage.
24	SIM_RST	SIM card reset.
25	SIM_DATA	SIM card data I/O.
26	SIM_CLK	SIM card clock.
27	SIM_GND	SIM card ground.
28	SIM_PRESENCE	SIM card detection

Figure 32 is the reference circuit for SIM interface, and here an 8-pin SIM card holder is used.

The pin SIM_PRESENCE is used to detect whether the tray of the Molex SIM socket, which is used for holding SIM card, is presented in the card socket. When the tray is inserted in the socket, SIM_PRESENCE is in low level. Regardless of the SIM card is in the tray or not, the change of SIM_PRESENCE level from high to low prompts the module to initialize SIM card. In default configuration, SIM card detection function is disabled. Customer's application can use "AT+QSIMDET=1,0" and "AT+QSIMDET=0,0" to switch on and off the SIM card detection function. For details of this AT command,

please refer to **document [1]**. When “AT+QSIMDET=1,0” is set and the tray with SIM card is removed from SIM socket, the following URC will be presented:

+CPIN: NOT INSERTED

When the tray with SIM card is inserted into SIM socket again and the module finishes reinitializing SIM card, the following URC will be presented:

+CPIN: READY

Call Ready

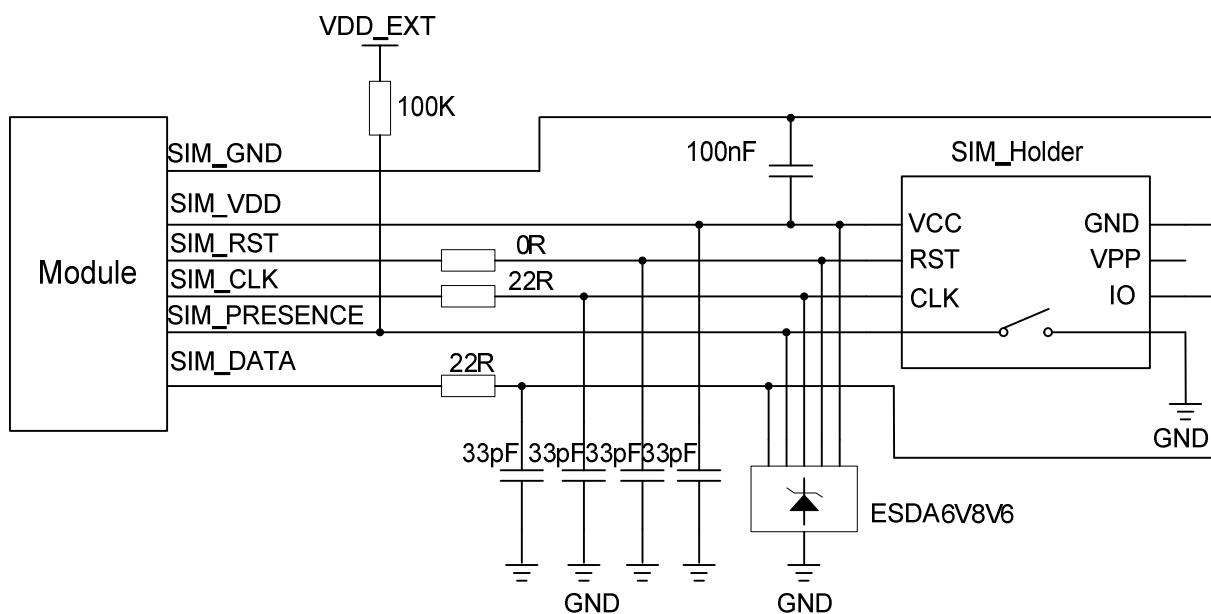

Figure 32: Reference Circuit for 8-pin SIM Card Holder

NOTE

1. Please do not use “AT+QSIMDET=1,1” when circuit in Figure 32 is adopted, which can cause to reinitialize SIM card.
2. When SIM card detection function is used, SIM_PRESENCE pin must be pulled up by an external resistor. If unused, please keep this pin open.

The reference circuit for a 6-pin SIM card socket is illustrated as the following figure:

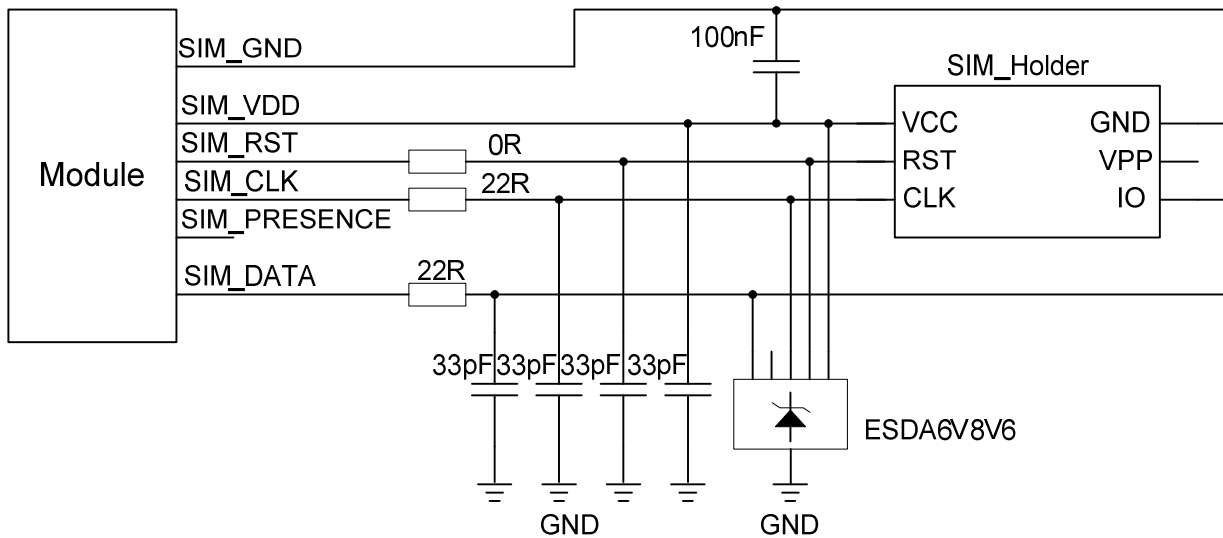

Figure 33: Reference Circuit for 6-pin SIM Card Holder

In order to enhance the reliability and availability of the SIM card in application. Please follow the criteria below in the SIM circuit design.

- Keep layout of SIM card as close as possible to the module. Assure the possibility of the length of the trace is less than 100mm.
- Keep SIM card signal away from RF and VBAT alignment.
- Assure the ground between module and SIM cassette short and wide. Keep the width of ground no less than 0.5mm to maintain the same electric potential. The decouple capacitor of SIM_VDD is less than 1uF and must be near to SIM cassette.
- To avoid cross talk between SIM_DATA and SIM_CLK. Keep them away with each other and shield them with surrounded ground.
- In order to offer good ESD protection, it is recommended to add TVS such as WILL (<http://www.willsemi.com/>) ESDA6V8AV6. The 22Ω resistors should be connected in series between the module and the SIM card so as to suppress the EMI spurious transmission and enhance the ESD protection. Please to be noted that the SIM peripheral circuit should be close to the SIM card socket.
- Place the RF bypass capacitors (33pF) close to the SIM card on all signals line for improving EMI.

3.9.2. SIM Cassette

As to the 6-pin SIM card holder, it is recommended to use Amphenol C707 10M006 512 2. Please visit <http://www.amphenol.com> for more information.

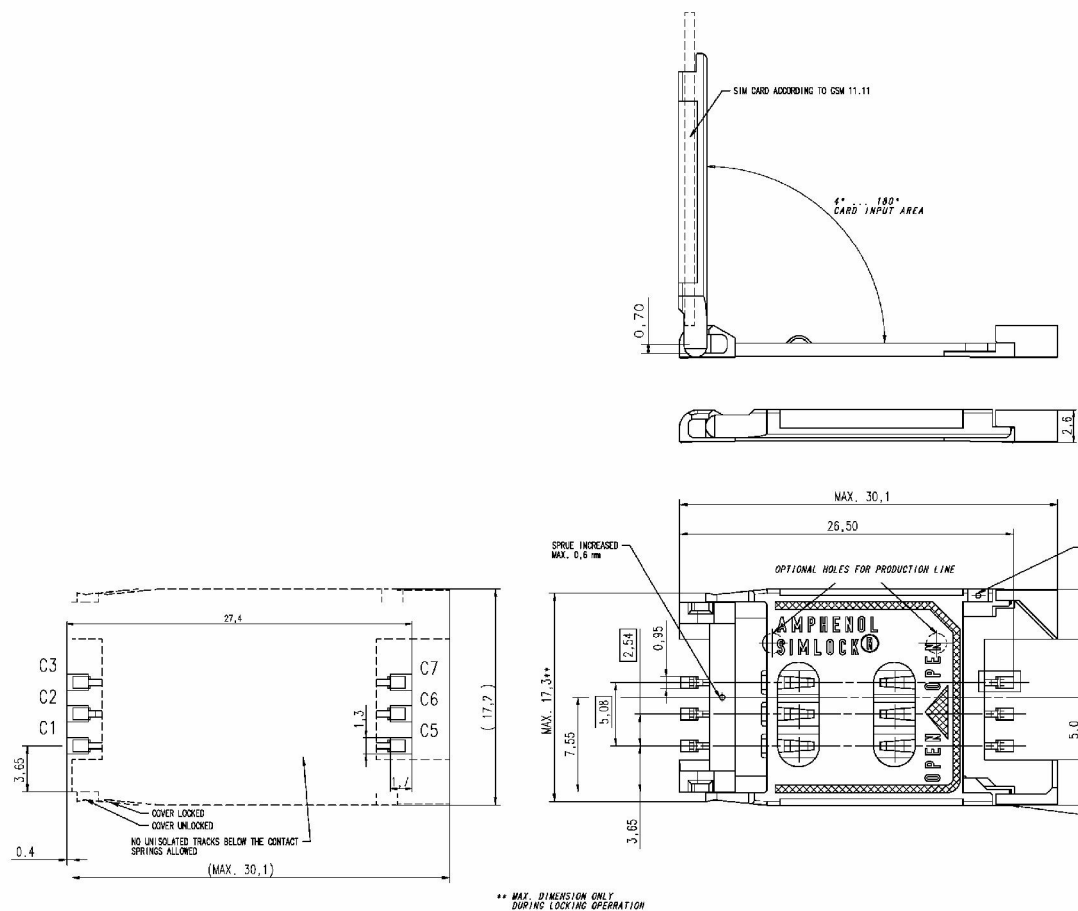

Figure 34: Amphenol C707 10M006 512 2 SIM Card Holder

Table 12: Pin Description of Amphenol SIM Card Holder

Name	Pin	Description
SIM_VDD	C1	SIM card power supply
SIM_RST	C2	SIM card reset
SIM_CLK	C3	SIM card clock
GND	C5	Ground
VPP	C6	Not connected
SIM_DATA	C7	SIM card data I/O

For 8-pin SIM card holder, it is recommended to use Molex 91228. Please visit <http://www.molex.com> for more information.

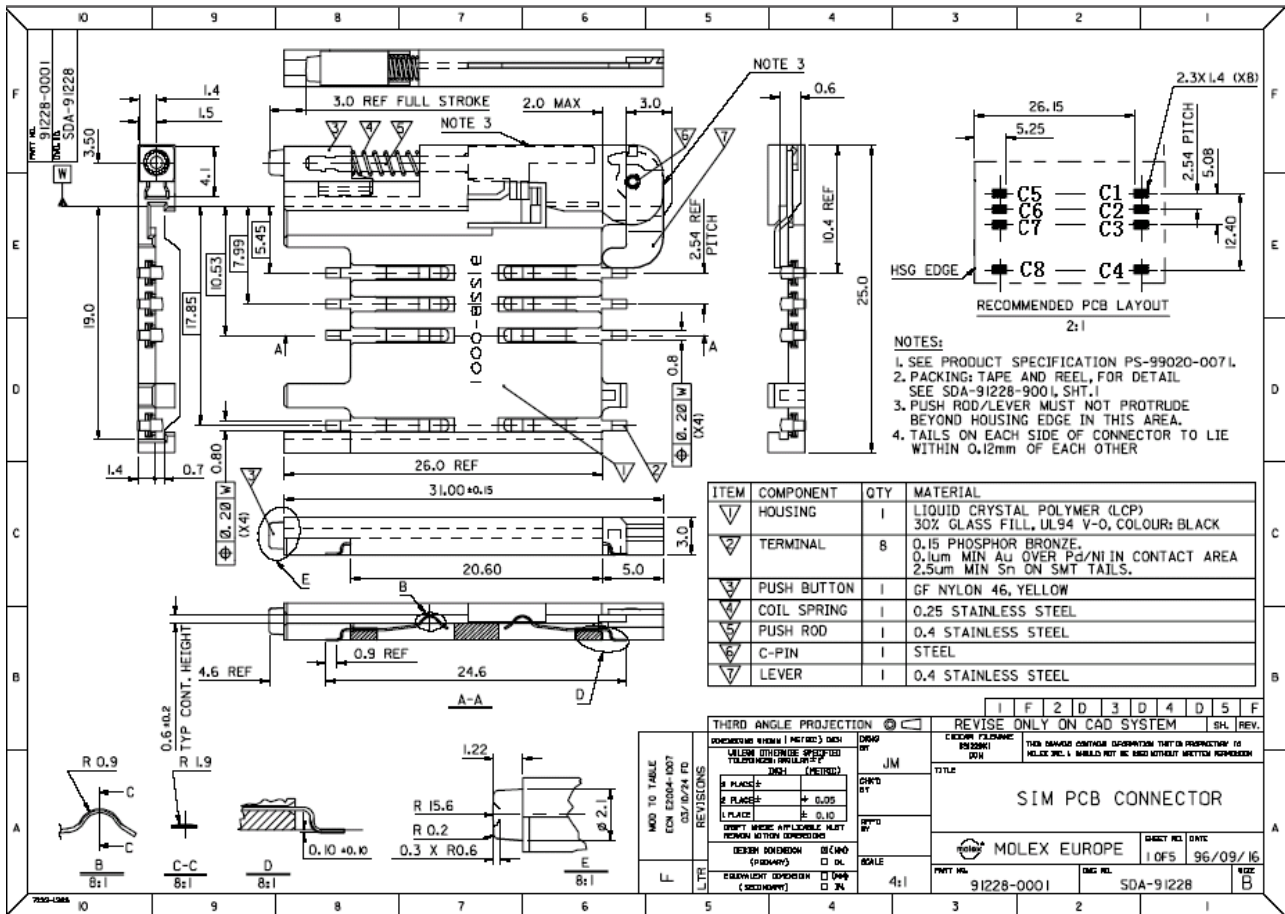

Figure 35: Molex 91228 SIM Card Holder

Table 13: Pin Description of Molex SIM Card Holder

Name	Pin	Description
SIM_VDD	C1	SIM card power supply
SIM_RST	C2	SIM card reset
SIM_CLK	C3	SIM card clock
SIM_PRESENCE	C4	SIM card presence detection
GND	C5	Ground
VPP	C6	Not connect
SIM_DATA	C7	SIM card data I/O
SIM_DETECT	C8	Pull down GND with external circuit. When the tray is presented, C4 is connected to C8.

3.10. PCM Interface

GC65 has reserved PCM interface, it is used as digital audio transmission between module and customer device. This interface composes PCM_CLK, PCM_SYNC, PCM_IN and PCM_OUT signal lines. PCM function is not supported at present.

3.11. Behaviors of the RI

Table 14: Behaviours of the RI

State	RI Response
Standby	HIGH
Voice Call	Change to LOW, then: <ol style="list-style-type: none"> 1. Change to HIGH when call is established. 2. Use ATH to hang up the call, RI changes to HIGH. 3. Calling part hangs up, RI changes to HIGH first, and changes to LOW for 120ms indicating "NO CARRIER" as an URC, then changes to HIGH again. 4. Change to HIGH when SMS is received.
SMS	When a new SMS comes, the RI changes to LOW and holds low level for about 120ms, then changes to HIGH.
URC	Certain URCs can trigger 120ms low level on RI. For more details, please refer to the <i>document [10]</i> .

If the module is used as a caller, the RI would maintain high unless the URC or SMS is received. On the other hand, when it is used as a receiver, the timing of the RI is shown below:

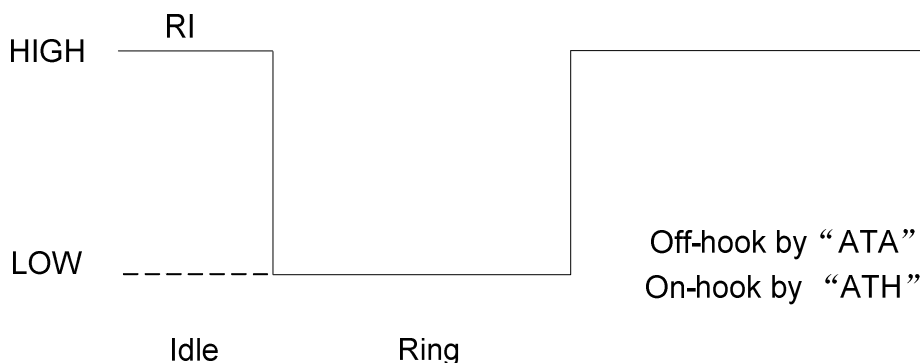

Figure 36: RI Behaviour of Voice Calling as a Receiver

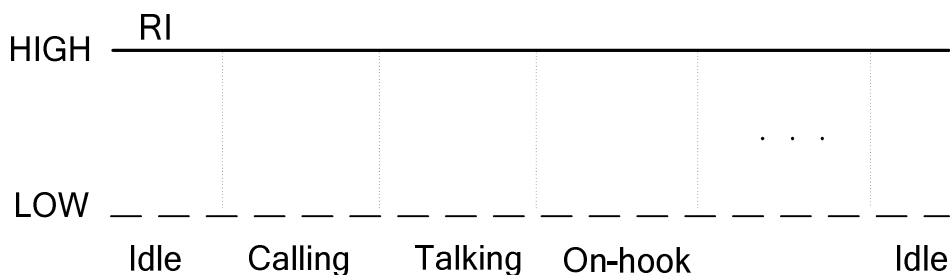

Figure 37: RI Behaviour as a Caller

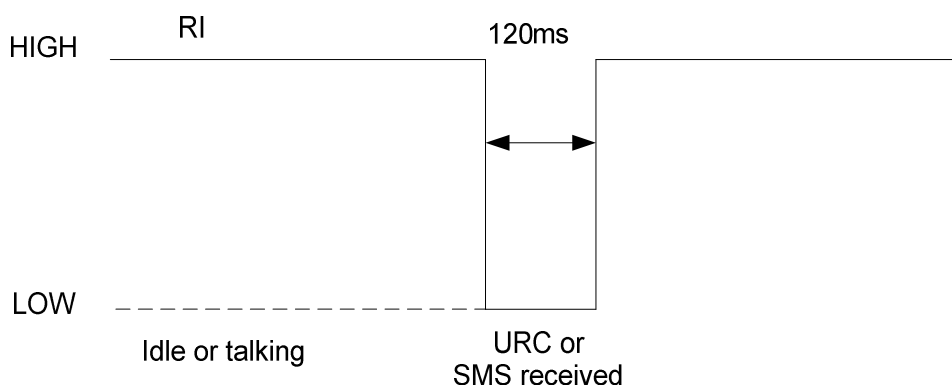

Figure 38: RI Behaviour of URC or SMS Received

3.12. Network Status Indication

The NETLIGHT signal can be used to drive a network status indicator LED. The working state of this pin is listed in the following table:

Table 15: Working State of the NETLIGHT

State	Module Function
Off	The module is not running.
64ms On/ 800ms Off	The module is not synchronized with network.
64ms On/ 2000ms Off	The module is synchronized with network.
64ms On/ 600ms Off	The GPRS data transmission after dialing the PPP connection.

A reference circuit is shown as below:

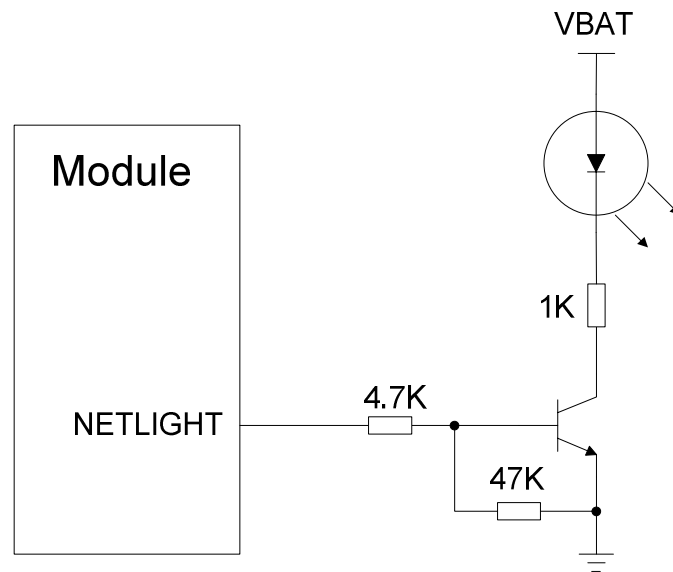

Figure 39: Reference Design for NETLIGHT

4 Antenna Interface

The Pin 38 is the RF antenna pad. The RF interface has an impedance of 50Ω.

Table 16: Pin Definition of the RF_ANT

Pin Name	Pin NO.	Description
GND	37	Ground
RF_ANT	38	RF antenna pad
GND	39	Ground

4.1. RF Reference Design

The reference design for RF is shown as below:

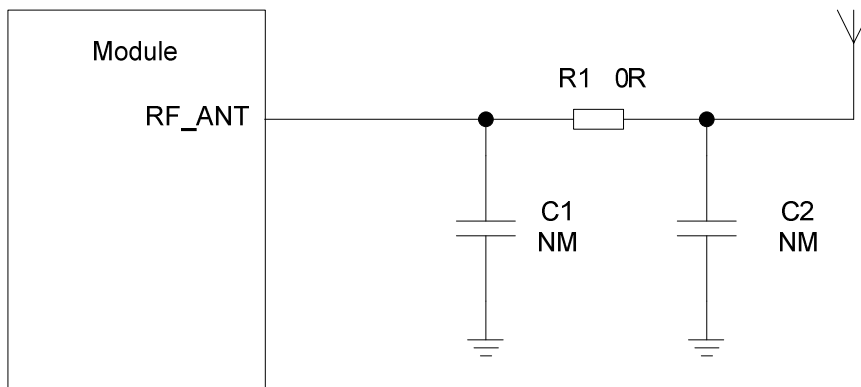

Figure 40: Reference Design for RF

GC65 provides an RF antenna pad for antenna connection. The RF trace in host PCB connected to the module RF antenna pad should be coplanar waveguide line or microstrip line, whose characteristic impedance should be close to 50Ω. GC65 comes with grounding pads which are next to the antenna pad in order to give a better grounding. Besides, a Π type match circuit is suggested to be used to adjust the RF performance.

To minimize the loss on the RF trace and RF cable, take design into account carefully. It is recommended that the insertion loss should meet the following requirements:

- GSM850/EGSM900 is <1dB.
- DCS1800/PCS1900 is <1.5dB.

4.2. RF Output Power

Table 17: The Module Conducted RF Output Power

Frequency	Max.	Min.
GSM850	33dBm±2dB	5dBm±5dB
EGSM900	33dBm±2dB	5dBm±5dB
DCS1800	30dBm±2dB	0dBm±5dB
PCS1900	30dBm±2dB	0dBm±5dB

4.3. RF Receiving Sensitivity

Table 18: The Module Conducted RF Receiving Sensitivity

Frequency	Receive Sensitivity
GSM850	< -108dBm
EGSM900	< -108dBm
DCS1800	< -108dBm
PCS1900	< -108dBm

4.4. Operating Frequencies

Table 19: The Module Operating Frequencies

Frequency	Receive	Transmit	ARFCH
GSM850	869~894MHz	824~849MHz	128~251
EGSM900	925~960MHz	880~915MHz	0~124, 975~1023
DCS1800	1805~1880MHz	1710~1785MHz	512~885
PCS1900	1930~1990MHz	1850~1910MHz	512~810

4.5. RF Cable Soldering

Soldering the RF cable to RF pad of module correctly will reduce the loss on the path of RF, please refer to the following example of RF soldering.



Figure 41: RF Soldering Sample

5 Electrical, Reliability and Radio Characteristics

5.1. Absolute Maximum Ratings

Absolute maximum ratings for power supply and voltage on digital and analog pins of module are listed in the following table:

Table 20: Absolute Maximum Ratings

Parameter	Min.	Max.	Unit
V _{BAT}	-0.3	5.0	V
Peak current of power supply	0	2	A
RMS current of power supply (during one TDMA- frame)	0	0.8	A
Voltage at digital pins	-0.3	3.3	V
Voltage at analog pins	-0.3	3.3	V
Voltage at digital/analog pins in power down mode	-0.25	0.25	V

5.2. Operating Temperature

The operating temperature is listed in the following table:

Table 21: Operating Temperature

Parameter	Min.	Typ.	Max.	Unit
Normal Temperature	-35	+25	+80	°C
Restricted Operation	-40 ~ -35		+80 ~ +85	°C
Storage Temperature	-45		+90	°C

5.3. Power Supply Ratings

Table 22: The Module Power Supply Ratings

Parameter	Description	Conditions	Min.	Typ.	Max.	Unit	
VBAT	Supply voltage	Voltage must stay within the min/max values, including voltage drop, ripple, and spikes.	3.3	4.0	4.6	V	
	Voltage drop during transmitting burst	Maximum power control level on GSM850 and GSM900.			400	mV	
	Voltage ripple	Maximum power control level on GSM850 and GSM900 @ f<200kHz @ f>200kHz			50 20	mV mV	
Average supply current		Power down mode		120		uA	
		Sleep mode @ DRX=5		1.3		mA	
		Minimum functionality mode					
		AT+CFUN=0					
		Idle mode		21		mA	
		Sleep mode		0.8		mA	
AT+CFUN=4							
Idle mode			21		mA		

	Sleep mode	0.8		mA
IVBAT	Talk mode			
	GSM850/EGSM900 ¹⁾	211/208		mA
	DCS1800/PCS1900 ²⁾	156/165		mA
	DATA mode, GPRS (3Rx/2Tx)			
	GSM850/EGSM900 ¹⁾	372/367		mA
	DCS1800/PCS1900 ²⁾	245/285		mA
	DATA mode, GPRS (4Rx/1Tx)			
	GSM850/EGSM900 ¹⁾	224/220		mA
	DCS1800/PCS1900 ²⁾	162/182		mA
Peak supply current (during transmission slot)	Maximum power control level on GSM850/GSM900.	1.6	1.8	A

NOTES

- 1) Power control level PCL 5.
- 2) Power control level PCL 0.

5.4. Current Consumption

The values of current consumption are shown as below:

Table 23: The Module Current Consumption

Condition	Current Consumption
Voice Call	
GSM850	@power level #5 <300mA, Typical 211mA @power level #12, Typical 86mA @power level #19, Typical 64mA
GSM900	@power level #5 <300mA, Typical 208mA @power level #12, Typical 85mA @power level #19, Typical 64mA
DCS1800	@power level #0 <250mA, Typical 156mA @power level #7, Typical 75mA @power level #15, Typical 64mA

PCS1900	@power level #0 <250mA, Typical 165mA @power level #7, Typical 80mA @power level #15, Typical 64mA
---------	--

GPRS Data

DATA mode, GPRS (3 Rx/2 Tx) CLASS 10

GSM850	@power level #5 <550mA, Typical 372mA @power level #12, Typical 132mA @power level #19, Typical 90mA
--------	--

EGSM 900	@power level #5 <550mA, Typical 367mA @power level #12, Typical 134mA @power level #19, Typical 92mA
----------	--

DCS 1800	@power level #0 <450mA, Typical 245mA @power level #7, Typical 113mA @power level #15, Typical 90mA
----------	---

PCS 1900	@power level #0 <450mA, Typical 285mA @power level #7, Typical 121mA @power level #15, Typical 90mA
----------	---

DATA mode, GPRS (4 Rx/1 Tx) CLASS 10

GSM850	@power level #5 <350mA, Typical 224mA @power level #12, Typical 103mA @power level #19, Typical 82mA
--------	--

EGSM 900	@power level #5 <350mA, Typical 220mA @power level #12, Typical 103mA @power level #19, Typical 82mA
----------	--

DCS 1800	@power level #0 <300mA, Typical 162mA @power level #7, Typical 96mA @power level #15, Typical 85mA
----------	--

PCS 1900	@power level #0 <300mA, Typical 182mA @power level #7, Typical 100mA @power level #15, Typical 85mA
----------	---

5.5. Electro-static Discharge

Although the GSM engine is generally protected against Electro-static Discharge (ESD), ESD protection precautions should still be emphasized. Proper ESD handling and packaging procedures must be applied throughout the processing, handling and operation of any applications using the module.

The measured ESD values of module are shown as the following table:

Table 24: The ESD Endurance (Temperature: 25°C, Humidity: 45 %)

Tested Point	Contact Discharge	Air Discharge
VBAT/GND	±6KV	±12KV
RF_ANT	±4KV	±12KV
RXD/TXD	±2KV	±4KV
Others	±0.5KV	±1KV

6 Mechanical Dimensions

This chapter describes the mechanical dimensions of the module.

6.1. Mechanical Dimensions of Module

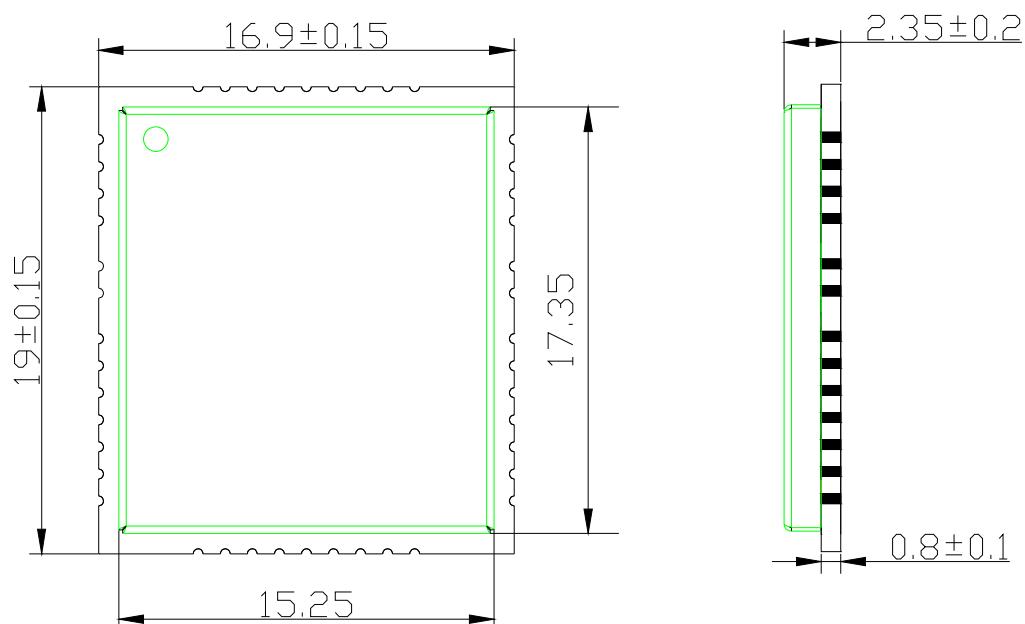

Figure 42: GC65 Module Top and Side Dimensions (Unit: mm)

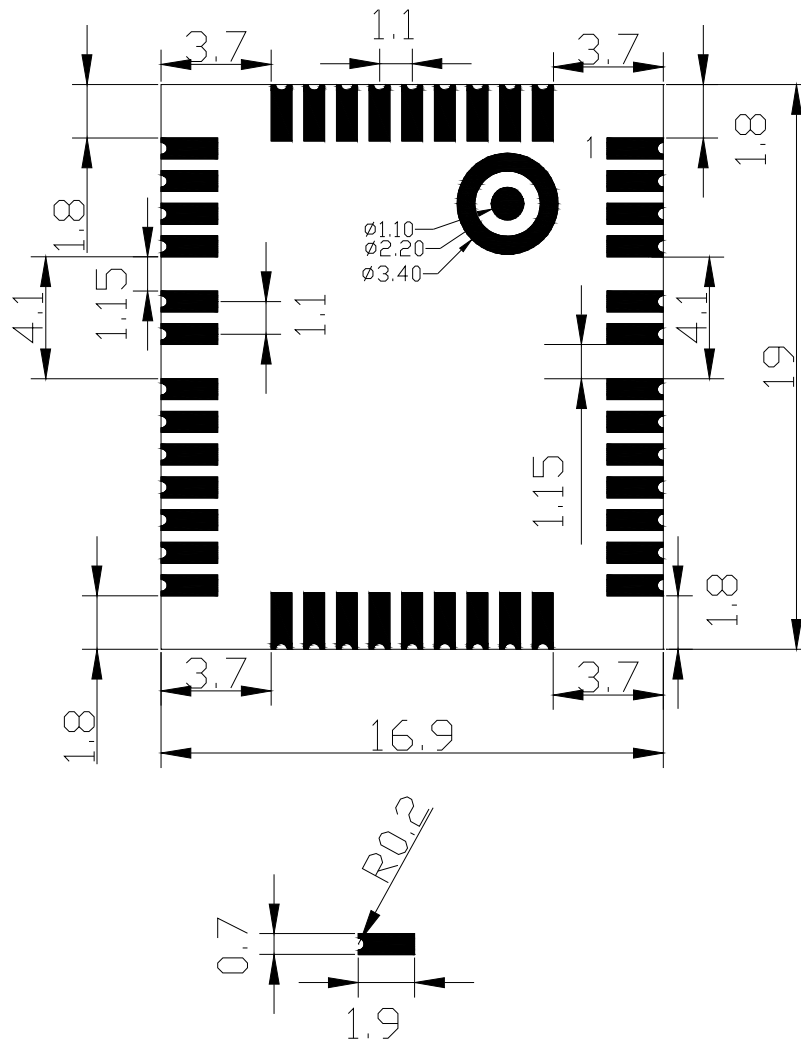

Figure 43: GC65 Module Bottom Dimensions (Unit: mm)

6.2. Recommended Footprint

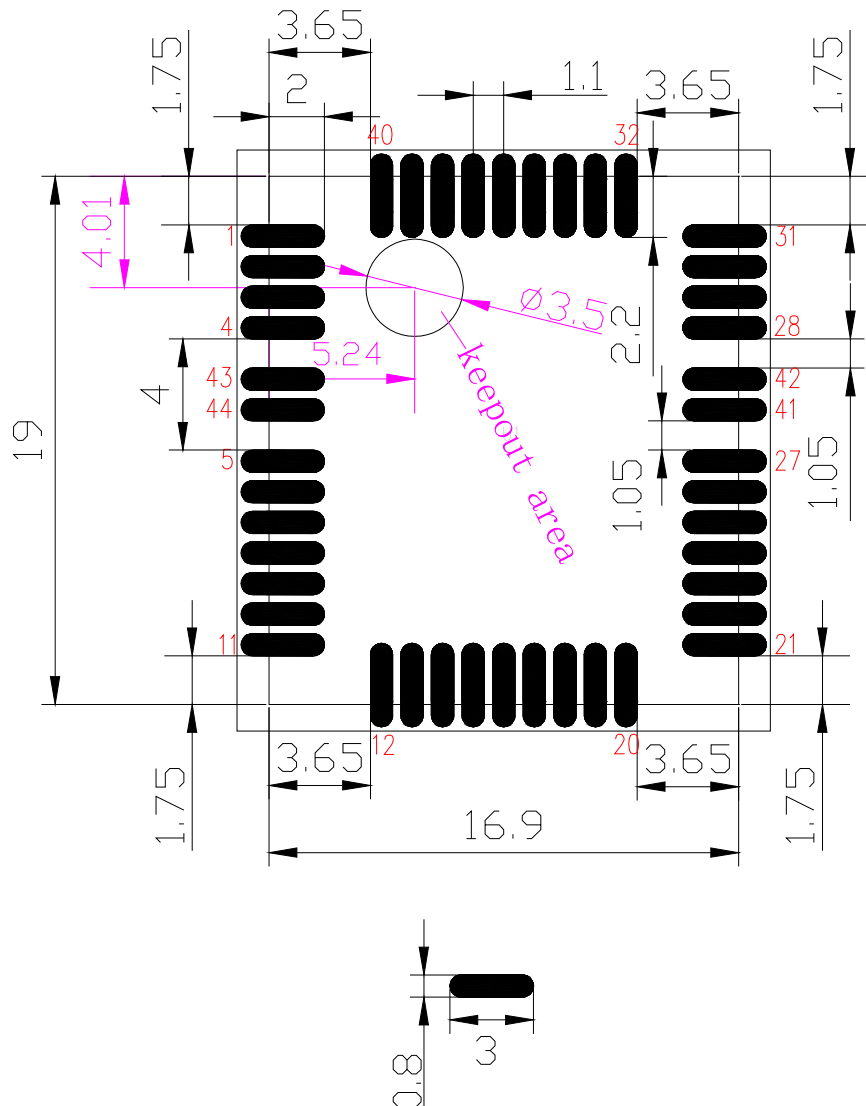

Figure 44: Recommended Footprint (Unit: mm)

NOTES

1. In order to maintain the module, keep about 3mm between the module and other components in the host PCB.
2. Keep out area in above figure is forbidden to pour ground copper. Since the RF test point is in this area, please avoid generating parasitic capacitance between RF test point and ground.

6.3. Top View of the Module



Figure 45: Top View of the Module

6.4. Bottom View of the Module

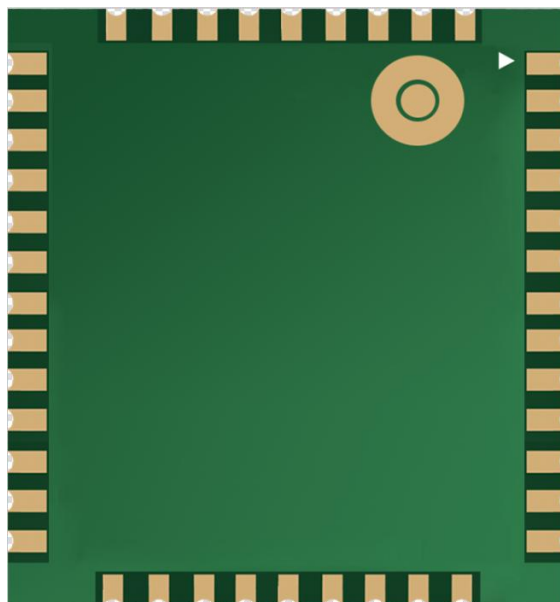

Figure 46: Bottom View of the Module

7 Storage and Manufacturing

7.1. Storage

GC65 module is distributed in a vacuum-sealed bag. The restriction for storage is shown as below.

Shelf life in the vacuum-sealed bag: 12 months at environments of $<40^{\circ}\text{C}$ temperature and $<90\% \text{RH}$.

After the vacuum-sealed bag is opened, devices that need to be mounted directly must be:

- Mounted within 72 hours at the factory environment of $\leq 30^{\circ}\text{C}$ temperature and $<60\% \text{RH}$.
- Stored at $<10\% \text{RH}$.

Devices require baking before mounting, if any circumstance below occurs.

- When the ambient temperature is $23^{\circ}\text{C} \pm 5^{\circ}\text{C}$, humidity indication card shows the humidity is $>10\%$ before opening the vacuum-sealed bag.
- If ambient temperature is $<30^{\circ}\text{C}$ and the humidity is $<60\%$, the devices have not been mounted during 72hours.
- Stored at $>10\% \text{RH}$ after opening the vacuum-sealed bag.

If baking is required, devices should be baked for 48 hours at $125^{\circ}\text{C} \pm 5^{\circ}\text{C}$.

NOTE

As plastic container cannot be subjected to high temperature, devices must be removed before high temperature (125°C) bake. If shorter bake times are desired, please refer to the IPC/JEDECJ-STD-033 for bake procedure.

7.2. Soldering

The squeegee should push the paste on the surface of the stencil that makes the paste fill the stencil openings and penetrate to the PCB. The force on the squeegee should be adjusted so as to produce a clean stencil surface on a single pass. To ensure the module soldering quality, the thickness of stencil at the hole of the module pads should be 0.2 mm for GC65.

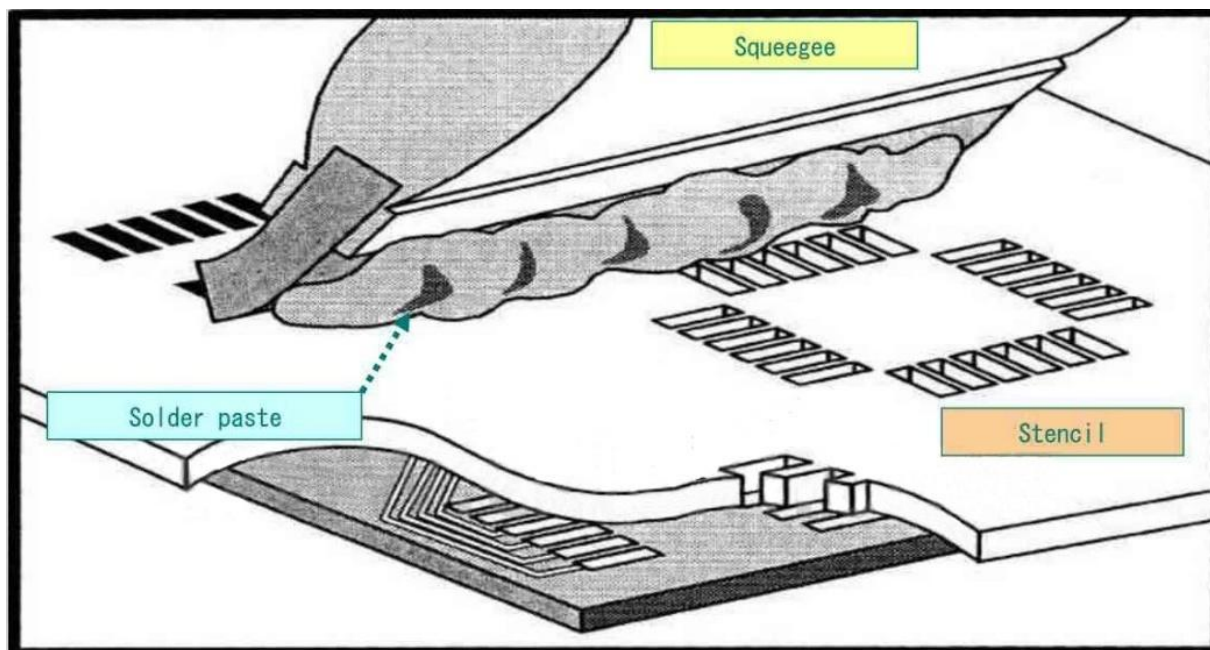

Figure 47: The Picture of Printing Paste

It is suggested that peak reflow temperature is from 235 °C to 245°C (for SnAg3.0Cu0.5 alloy). Absolute max reflow temperature is 260°C. To avoid damaging the module when it was repeatedly heated, it is suggested that the module should be mounted after the first panel has been reflowed. The following picture is the actual diagram which we have operated.

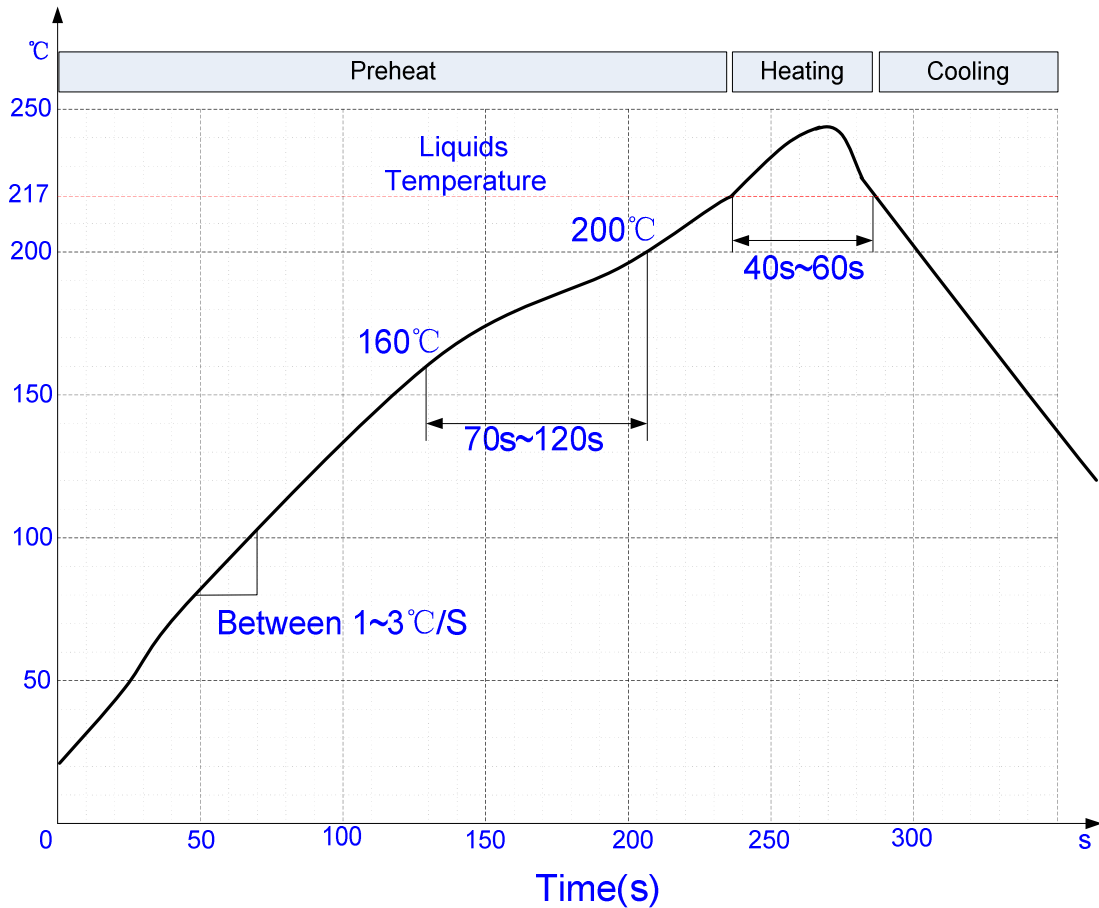

Figure 48: Ramp-Soak-Spike Reflow Profile

7.3. Packaging

The modules are stored inside a vacuum-sealed bag which is ESD-protected. It should not be opened until the devices are ready to be soldered onto the application.

7.3.1. Tape and Reel Packaging

The reel is 330mm in diameter and each reel contains 250 modules.

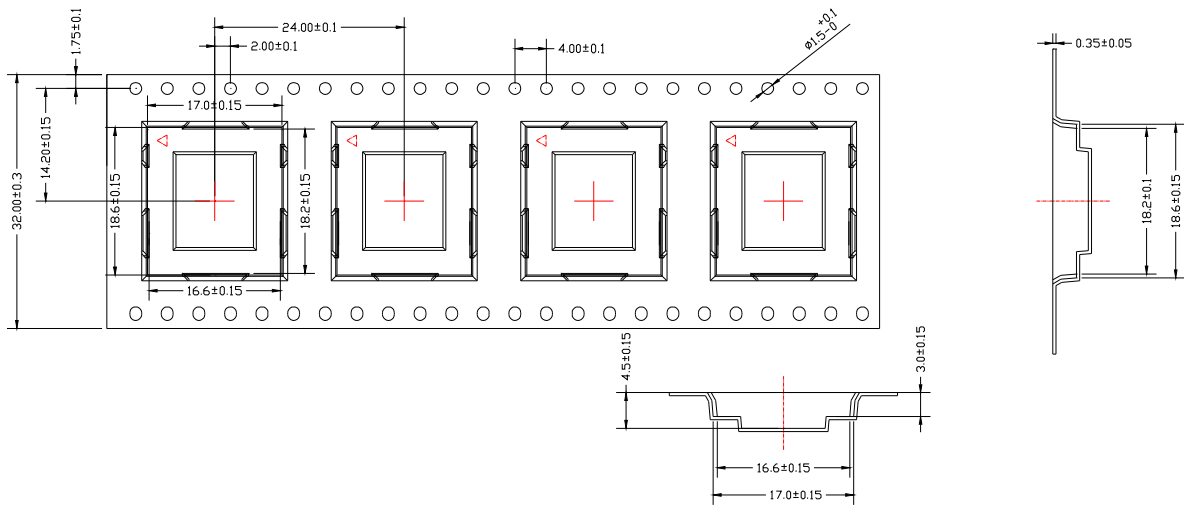

Figure 49: Dimensions of Tape

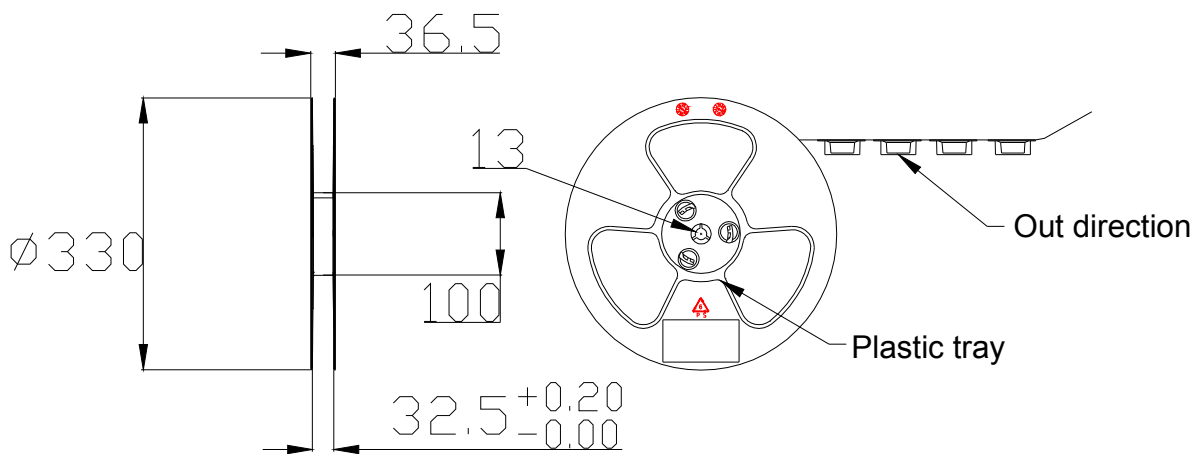

Figure 50: Dimensions of Reel

8 Appendix A Reference

Table 25: Related Documents

SN	Document Name	Remark
[1]	GC65_AT_Commands_Manual	AT commands manual
[2]	ITU-T Draft new recommendation V.25ter	Serial asynchronous automatic dialing and control
[3]	GSM 07.07	Digital cellular telecommunications (Phase 2+); AT command set for GSM Mobile Equipment (ME)
[4]	GSM 07.10	Support GSM 07.10 multiplexing protocol
[5]	GSM 07.05	Digital cellular telecommunications (Phase 2+); Use of Data Terminal Equipment–Data Circuit terminating Equipment (DTE–DCE) interface for Short Message Service (SMS) and Cell Broadcast Service (CBS)
[6]	GSM 11.14	Digital cellular telecommunications (Phase 2+); Specification of the SIM application toolkit for the Subscriber Identity module–Mobile Equipment (SIM–ME) interface
[7]	GSM 11.11	Digital cellular telecommunications (Phase 2+); Specification of the Subscriber Identity module – Mobile Equipment (SIM–ME) interface
[8]	GSM 03.38	Digital cellular telecommunications (Phase 2+); Alphabets and language-specific information
[9]	GSM 11.10	Digital cellular telecommunications (Phase 2); Mobile Station (MS) conformance specification; Part 1: Conformance specification
[10]	GSM_UART_AN	UART port application note
[11]	M10_EVB_UGD	M10 EVB user guide
[12]	GSM_FW_Upgrade_AN01	GSM Firmware upgrade application note

Table 26: Terms and Abbreviations

Abbreviation	Description
AMR	Adaptive Multi-Rate
ARP	Antenna Reference Point
ASIC	Application Specific Integrated Circuit
BER	Bit Error Rate
BOM	Bill of Material
BTS	Base Transceiver Station
CHAP	Challenge Handshake Authentication Protocol
CS	Coding Scheme
CSD	Circuit Switched Data
CTS	Clear to Send
DRX	Discontinuous Reception
DCE	Data Communications Equipment (typically module)
DTE	Data Terminal Equipment (typically computer, external controller)
DTR	Data Terminal Ready
DTX	Discontinuous Transmission
EFR	Enhanced Full Rate
EGSM	Enhanced GSM
EMC	Electromagnetic Compatibility
EMI	Electromagnetic Interference
ESD	Electrostatic Discharge
ETS	European Telecommunication Standard
FCC	Federal Communications Commission (U.S.)
FDMA	Frequency Division Multiple Access

FR	Full Rate
FTP	File Transfer Protocol
GMSK	Gaussian Minimum Shift Keying
GPRS	General Packet Radio Service
GSM	Global System for Mobile Communications
HR	Half Rate
HTTP	Hypertext Transport Protocol
IMEI	International Mobile Equipment Identity
MO	Mobile Originated
MS	Mobile Station (GSM engine)
MT	Mobile Terminated
PAP	Password Authentication Protocol
PBCCH	Packet Switched Broadcast Control Channel
PCB	Printed Circuit Board
PDU	Protocol Data Unit
PDP	Packet Data Protocol
PPP	Point-to-Point Protocol
RF	Radio Frequency
RMS	Root Mean Square (value)
RTC	Real Time Clock
RX	Receive Direction
SIM	Subscriber Identification Module
SMS	Short Message Service
SMTP	Simple Mail Transfer Protocol
TDMA	Time Division Multiple Access

TE	Terminal Equipment
TX	Transmitting Direction
UART	Universal Asynchronous Receiver & Transmitter
UDP	User Datagram Protocol
URC	Unsolicited Result Code
USSD	Unstructured Supplementary Service Data
VSWR	Voltage Standing Wave Ratio

Phonebook Abbreviations

FD	SIM Fix Dialing Phonebook
LD	SIM Last Dialing Phonebook (list of numbers most recently dialed)
ON	SIM (or ME) Own Numbers (MSISDNs) List
SM	SIM Phonebook

9 Appendix B GPRS Coding Scheme

Four coding schemes are used in GPRS protocol. The differences between them are shown in the following table:

Table 27: Description of Different Coding Schemes

Scheme	Code Rate	USF	Pre-coded USF	Radio Block excl.USF and BCS	BCS	Tail	Coded Bits	Punctured Bits	Data Rate Kb/s
CS-1	1/2	3	3	181	40	4	456	0	9.05
CS-2	2/3	3	6	268	16	4	588	132	13.4
CS-3	3/4	3	6	312	16	4	676	220	15.6
CS-4	1	3	12	428	16	-	456	-	21.4

Radio block structure of CS-1, CS-2 and CS-3 is shown as the figure below:

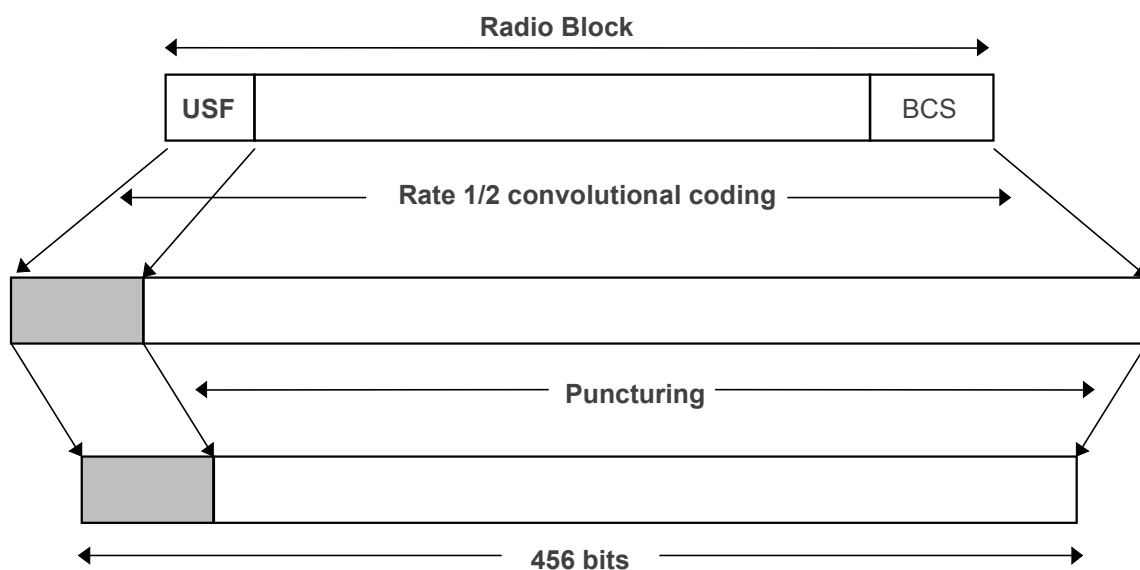

Figure 51: Radio Block Structure of CS-1, CS-2 and CS-3

Radio block structure of CS-4 is shown as the following figure:

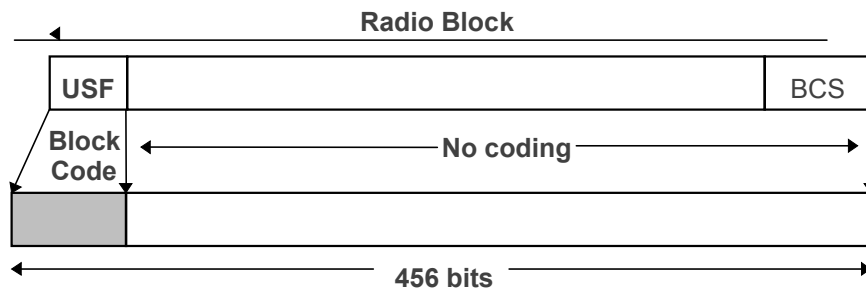

Figure 52: Radio Block Structure of CS-4

10 Appendix C GPRS Multi-slot Class

Twenty-nine classes of GPRS multi-slot modes are defined for MS in GPRS specification. Multi-slot classes are product dependant, and determine the maximum achievable data rates in both the uplink and downlink directions. Written as 3+1 or 2+2, the first number indicates the amount of downlink timeslots, while the second number indicates the amount of uplink timeslots. The active slots determine the total number of slots the GPRS device can use simultaneously for both uplink and downlink communications.

The description of different multi-slot classes is shown in the following table:

Table 28: GPRS Multi-slot Classes

Multislot Class	Downlink Slots	Uplink Slots	Active Slots
1	1	1	2
2	2	1	3
3	2	2	3
4	3	1	4
5	2	2	4
6	3	2	4
7	3	3	4
8	4	1	5
9	3	2	5
10	4	2	5
11	4	3	5
12	4	4	5