

M35 User Manual

GSM/GPRS Module Series

Rev. M35_User_Manual_V3.1

Date: 2014-11-26



Our aim is to provide customers with timely and comprehensive service. For any assistance, please contact our company headquarters:

Quectel Wireless Solutions Co., Ltd.

Office 501, Building 13, No.99, Tianzhou Road, Shanghai, China, 200233

Tel: +86 21 5108 6236

Mail: info@quectel.com

Or our local office, for more information, please visit:

<http://www.quectel.com/support/salesupport.aspx>

For technical support, to report documentation errors, please visit:

<http://www.quectel.com/support/techsupport.aspx>

GENERAL NOTES

QUECTEL OFFERS THIS INFORMATION AS A SERVICE TO ITS CUSTOMERS. THE INFORMATION PROVIDED IS BASED UPON CUSTOMERS' REQUIREMENTS. QUECTEL MAKES EVERY EFFORT TO ENSURE THE QUALITY OF THE INFORMATION IT MAKES AVAILABLE. QUECTEL DOES NOT MAKE ANY WARRANTY AS TO THE INFORMATION CONTAINED HEREIN, AND DOES NOT ACCEPT ANY LIABILITY FOR ANY INJURY, LOSS OR DAMAGE OF ANY KIND INCURRED BY USE OF OR RELIANCE UPON THE INFORMATION. ALL INFORMATION SUPPLIED HEREIN IS SUBJECT TO CHANGE WITHOUT PRIOR NOTICE.

COPYRIGHT

THIS INFORMATION CONTAINED HERE IS PROPRIETARY TECHNICAL INFORMATION OF QUECTEL CO., LTD. TRANSMITTABLE, REPRODUCTION, DISSEMINATION AND EDITING OF THIS DOCUMENT AS WELL AS UTILIZATION OF THIS CONTENTS ARE FORBIDDEN WITHOUT PERMISSION. OFFENDERS WILL BE HELD LIABLE FOR PAYMENT OF DAMAGES. ALL RIGHTS ARE RESERVED IN THE EVENT OF A PATENT GRANT OR REGISTRATION OF A UTILITY MODEL OR DESIGN.

Copyright © Quectel Wireless Solutions Co., Ltd. 2015. All rights reserved.

About the Document

History

Revision	Date	Author	Description
1.0	2011-12-29	Luka WU	Initial
1.1	2012-05-18	Luka WU	<ol style="list-style-type: none"> 1. Added current consumption in GPRS communication mode. 2. Modified AT command AT+QAUDCH in Chapter 3.10. 3. Modified the Footprint of recommendation. 4. Updated module package type.
1.2	2012-09-19	Luka WU	<ol style="list-style-type: none"> 1. Updated module functional diagram. 2. Updated Voltage ripple during transmitting. 3. Modified level match reference circuits for 5V peripheral system. 4. Updated SIM card reference circuit. 5. Added module current consumption.
1.3	2013-09-03	Winter CHEN	<ol style="list-style-type: none"> 1. Updated information on module's packaging. 2. Used the new technical document template.
1.4	2013-11-04	Felix YIN	Optimized the parameters of VBAT ripple in Table 24.
3.0	2014-07-25	Winter CHEN	<ol style="list-style-type: none"> 1. Added information for SIM2 interface, DTR and DCD pin. 2. Added information for Multi UART. 3. Modified module's current consumption. 4. Modified module's pin definition. 5. Modified DC characteristics of module pin.
3.1	2014-11-26	Winter CHEN	<ol style="list-style-type: none"> 1. Added information for PCM interface. 2. Updated Figure 5: Reference Circuit for Power Supply. 3. Modified over-voltage or under-voltage automatic shutdown in Section 3.4.2 4. Modified RTC backup in Section 3.6

-
5. Modified UART application in Section 3.7.3
 6. Modified SIM card interface in Section 3.10
 7. Added antenna requirement in Section 4.5
-

Contents

About the Document	2
Contents	4
Table Index	7
Figure Index	8
1 Introduction	10
1.1. Safety Information	11
2 Product Concept	12
2.1. General Description.....	12
2.2. Directives and Standards	12
2.2.1. FCC Radiation Exposure Statement.....	12
2.3. Key Features	13
2.4. Functional Diagram	15
2.5. Evaluation Board	16
3 Application Interface	17
3.1. Pin of Module.....	18
3.1.1. Pin Assignment	18
3.1.2. Pin Description	19
3.2. Operating Modes.....	23
3.3. Power Supply	25
3.3.1. Power Features of Module.....	25
3.3.2. Decrease Supply Voltage Drop.....	25
3.3.3. Reference Design for Power Supply.....	26
3.3.4. Monitor Power Supply	27
3.4. Power On and Down Scenarios	27
3.4.1. Power On	27
3.4.2. Power Down.....	29
3.4.2.1. Power Down Module Using the PWRKEY Pin.....	29
3.4.2.2. Power Down Module Using AT Command.....	30
3.4.2.3. Over-voltage or Under-voltage Automatic Shutdown.....	30
3.4.2.4. Emergency Shutdown Using EMERG_OFF Pin.....	31
3.4.3. Restart.....	32
3.5. Power Saving	33
3.5.1. Minimum Functionality Mode	33
3.5.2. SLEEP Mode.....	34
3.5.3. Wake Up Module from SLEEP Mode.....	34
3.5.4. Summary of State Transition.....	35
3.6. RTC Backup	35
3.7. Serial Interfaces.....	37

3.7.1.	UART Port	39
3.7.1.1.	The Features of UART Port.....	39
3.7.1.2.	The Connection of UART	40
3.7.1.3.	Firmware Upgrade.....	42
3.7.2.	Debug Port	42
3.7.3.	UART Application	43
3.8.	Audio Interfaces.....	44
3.8.1.	Decrease TDD Noise and Other Noise.....	46
3.8.2.	Microphone Interfaces Design	46
3.8.3.	Receiver Interface Design.....	47
3.8.4.	Earphone Interface Design	47
3.8.5.	Loud Speaker Interface Design	48
3.8.6.	Audio Characteristics	48
3.9.	PCM Interface.....	49
3.9.1.	Configuration	50
3.9.2.	Timing.....	50
3.9.3.	Reference Design	52
3.9.4.	AT Command	52
3.10.	SIM Card Interfaces	53
3.10.1.	SIM Card Application.....	53
3.11.	Behaviors of The RI.....	57
3.12.	Network Status Indication.....	58
3.13.	Operating Status Indication.....	59
4	Antenna Interface.....	61
4.1.	RF Reference Design	61
4.2.	RF Output Power.....	62
4.3.	RF Receiving Sensitivity.....	62
4.4.	Operating Frequencies.....	63
4.5.	Antenna Requirement	63
4.6.	RF Cable Soldering	64
5	Electrical, Reliability and Radio Characteristics	65
5.1.	Absolute Maximum Ratings.....	65
5.2.	Operating Temperature	65
5.3.	Power Supply Ratings	66
5.4.	Current Consumption	67
5.5.	Electro-static Discharge	68
6	Mechanical Dimensions	70
6.1.	Mechanical Dimensions of Module	70
6.2.	Recommended Footprint.....	72
6.3.	Top View of the Module	73
6.4.	Bottom View of the Module	73
7	Storage and Manufacturing	74

7.1.	Storage	74
7.2.	Soldering	74
7.3.	Packaging.....	75
7.3.1.	Tape and Reel Packaging	75
8	Appendix A Reference.....	78
9	Appendix B GPRS Coding Scheme	83
10	Appendix C GPRS Multi-slot Class.....	85

Table Index

TABLE 1: MODULE KEY FEATURES	13
TABLE 2: CODING SCHEMES AND MAXIMUM NET DATA RATES OVER AIR INTERFACE	15
TABLE 3: PIN DESCRIPTION	19
TABLE 4: MULTIPLEXED FUNCTIONS.....	23
TABLE 5: OVERVIEW OF OPERATING MODES.....	23
TABLE 6: SUMMARY OF STATE TRANSITION	35
TABLE 7: LOGIC LEVELS OF THE UART INTERFACES	38
TABLE 8: PIN DEFINITION OF THE UART INTERFACES	38
TABLE 9: PIN DEFINITION OF AUDIO INTERFACE	44
TABLE 10: AOUT2 OUTPUT CHARACTERISTICS.....	45
TABLE 11: TYPICAL ELECTRET MICROPHONE CHARACTERISTICS	48
TABLE 12: TYPICAL SPEAKER CHARACTERISTICS	48
TABLE 13: PIN DEFINITION OF PCM INTERFACE.....	49
TABLE 14: CONFIGURATION.....	50
TABLE 15: QPCMON COMMAND DESCRIPTION	53
TABLE 16: QPCMVOL COMMAND DESCRIPTION.....	53
TABLE 17: PIN DEFINITION OF THE SIM INTERFACES.....	54
TABLE 18: BEHAVIORS OF THE RI	57
TABLE 19: WORKING STATE OF THE NETLIGHT.....	58
TABLE 20: PIN DEFINITION OF THE STATUS	59
TABLE 21: PIN DEFINITION OF THE RF_ANT.....	61
TABLE 22: THE MODULE CONDUCTED RF OUTPUT POWER	62
TABLE 23: THE MODULE CONDUCTED RF RECEIVING SENSITIVITY	62
TABLE 24: THE MODULE OPERATING FREQUENCIES.....	63
TABLE 25: ANTENNA CABLE REQUIREMENTS.....	63
TABLE 26: ANTENNA REQUIREMENTS.....	63
TABLE 27: ABSOLUTE MAXIMUM RATINGS	65
TABLE 28: OPERATING TEMPERATURE.....	65
TABLE 29: THE MODULE POWER SUPPLY RATINGS	66
TABLE 30: THE MODULE CURRENT CONSUMPTION	67
TABLE 31: THE ESD ENDURANCE (TEMPERATURE: 25°C, HUMIDITY: 45%).....	69
TABLE 32: REEL PACKING	77
TABLE 33: RELATED DOCUMENTS.....	78
TABLE 34: TERMS AND ABBREVIATIONS	79
TABLE 35: DESCRIPTION OF DIFFERENT CODING SCHEMES	83
TABLE 36: GPRS MULTI-SLOT CLASSES	85

Figure Index

FIGURE 1: MODULE FUNCTIONAL DIAGRAM.....	16
FIGURE 2: PIN ASSIGNMENT	18
FIGURE 3: VOLTAGE RIPPLE DURING TRANSMITTING	25
FIGURE 4: REFERENCE CIRCUIT FOR THE VBAT INPUT	26
FIGURE 5: REFERENCE CIRCUIT FOR POWER SUPPLY	26
FIGURE 6: TURN ON THE MODULE WITH AN OPEN-COLLECTOR DRIVER.....	27
FIGURE 7: TURN ON THE MODULE WITH A BUTTON	28
FIGURE 8: TURN-ON TIMING	28
FIGURE 9: TURN-OFF TIMING	29
FIGURE 10: AN OPEN-COLLECTOR DRIVER FOR EMERG_OFF	31
FIGURE 11: REFERENCE CIRCUIT FOR EMERG_OFF BY USING BUTTON	32
FIGURE 12: TIMING OF RESTARTING SYSTEM.....	32
FIGURE 13: TIMING OF RESTARTING SYSTEM AFTER EMERGENCY SHUTDOWN	33
FIGURE 14: VRTC IS SUPPLIED BY A NON-CHARGEABLE BATTERY	36
FIGURE 15: VRTC IS SUPPLIED BY A RECHARGEABLE BATTERY	36
FIGURE 16: VRTC IS SUPPLIED BY A CAPACITOR	36
FIGURE 17: REFERENCE DESIGN FOR FULL-FUNCTION UART	40
FIGURE 18: REFERENCE DESIGN FOR UART PORT.....	41
FIGURE 19: REFERENCE DESIGN FOR UART PORT WITH HARDWARE FLOW CONTROL	41
FIGURE 20: REFERENCE DESIGN FOR FIRMWARE UPGRADE.....	42
FIGURE 21: REFERENCE DESIGN FOR DEBUG PORT	43
FIGURE 22: LEVEL MATCH DESIGN FOR 3.3V SYSTEM.....	43
FIGURE 23: SKETCH MAP FOR RS-232 INTERFACE MATCH.....	44
FIGURE 24: REFERENCE DESIGN FOR AIN1&AIN2	46
FIGURE 25: REFERENCE INTERFACE DESIGN OF AOUT1.....	47
FIGURE 26: EARPHONE INTERFACE DESIGN.....	47
FIGURE 27: LOUD SPEAKER INTERFACE DESIGN.....	48
FIGURE 28: LONG SYNCHRONIZATION & SIGN EXTENSION DIAGRAM	51
FIGURE 29: LONG SYNCHRONIZATION & ZERO PADDING DIAGRAM.....	51
FIGURE 30: SHORT SYNCHRONIZATION & SIGN EXTENSION DIAGRAM.....	51
FIGURE 31: SHORT SYNCHRONIZATION & ZERO PADDING DIAGRAM	52
FIGURE 32: REFERENCE DESIGN FOR PCM	52
FIGURE 33: REFERENCE CIRCUIT FOR SIM1 INTERFACE WITH 8-PIN SIM CARD HOLDER	55
FIGURE 34: REFERENCE CIRCUIT FOR SIM1 INTERFACE WITH THE 6-PIN SIM CARD HOLDER	55
FIGURE 35: REFERENCE CIRCUIT FOR SIM2 INTERFACE WITH THE 6-PIN SIM CARD HOLDER	56
FIGURE 36: RI BEHAVIOR OF VOICE CALLING AS A RECEIVER	57
FIGURE 37: RI BEHAVIOR AS A CALLER	58
FIGURE 38: RI BEHAVIOR OF URC OR SMS RECEIVED	58
FIGURE 39: REFERENCE DESIGN FOR NETLIGHT	59
FIGURE 40: REFERENCE DESIGN FOR STATUS.....	60
FIGURE 41: REFERENCE DESIGN FOR RF	61

FIGURE 42: RF SOLDERING SAMPLE	64
FIGURE 43: M35 MODULE TOP AND SIDE DIMENSIONS (UNIT: MM)	70
FIGURE 44: M35 MODULE BOTTOM DIMENSIONS (UNIT: MM)	71
FIGURE 45: RECOMMENDED FOOTPRINT (UNIT: MM).....	72
FIGURE 46: TOP VIEW OF THE MODULE	73
FIGURE 47: BOTTOM VIEW OF THE MODULE.....	73
FIGURE 48: RAMP-SOAK-SPIKE REFLOW PROFILE.....	75
FIGURE 49: TAPE AND REEL SPECIFICATION.....	76
FIGURE 50: DIMENSIONS OF REEL.....	77
FIGURE 51: RADIO BLOCK STRUCTURE OF CS-1, CS-2 AND CS-3.....	83
FIGURE 52: RADIO BLOCK STRUCTURE OF CS-4.....	84

1 Introduction

This document defines the M35 module and describes its hardware interface which are connected with your application and the air interface.

This document can help you quickly understand module interface specifications, electrical and mechanical details. Associated with application notes and user guide, you can use M35 module to design and set up mobile applications easily.

1.1. Safety Information

The following safety precautions must be observed during all phases of the operation, such as usage, service or repair of any cellular terminal or mobile incorporating M35 module. Manufacturers of the cellular terminal should send the following safety information to users and operating personnel and to incorporate these guidelines into all manuals supplied with the product. If not so, Quectel does not take on any liability for your failure to comply with these precautions.



Full attention must be given to driving at all times in order to reduce the risk of an accident. Using a mobile while driving (even with a handsfree kit) cause distraction and can lead to an accident. You must comply with laws and regulations restricting the use of wireless devices while driving.



Switch off the cellular terminal or mobile before boarding an aircraft. Make sure it switched off. The operation of wireless appliances in an aircraft is forbidden to prevent interference with communication systems. Consult the airline staff about the use of wireless devices on boarding the aircraft. If your device offers a Flight Mode which must be enabled prior to boarding an aircraft.



Switch off your wireless device when in hospitals or clinics or other health care facilities. These requests are desinged to prevent possible interference with sentitive medical equipment.



Cellular terminals or mobiles operate over radio frequency signal and cellular network and cannot be guaranteed to connect in all conditions, for example no mobile fee or an invalid SIM card. While you are in this condition and need emergent help, please remember using emergency call. In order to make or receive call, the cellular terminal or mobile must be switched on and in a service area with adequate cellular signal strength.



Your cellular terminal or mobile contains a transmitter and receiver. When it is ON , it receives and transmits radio frequency energy. RF interference can occur if it is used close to TV set, radio, computer or other electric equipment.



In locations with potentially explosive atmospheres, obey all posted signs to turn off wireless devices such as your phone or other cellular terminals. Areas with potentially expositive atmospheres including fuelling areas, below decks on boats, fuel or chemical transfer or storage facilities, areas where the air contains chemicals or particles such as grain, dust or metal powders.

2 Product Concept

2.1. General Description

M35 is a Quad-band GSM/GPRS engine that works at frequencies of GSM850MHz, EGSM900, DCS1800 and PCS1900MHz. The M35 features GPRS multi-slot class 12 and supports the GPRS coding schemes CS-1, CS-2, CS-3 and CS-4. For more details about GPRS multi-slot classes and coding schemes, please refer to the **Appendix B & C**.

With a tiny profile of 19.9mm × 23.6mm × 2.65mm, the module can meet almost all the requirements for M2M applications, including Vehicles and Personal Tracking, Security System, Wireless POS, Industrial PDA, Smart Metering, and Remote Maintenance & Control, etc.

M35 is an SMD type module with LCC package, which can be easily embedded into applications. It provides abundant hardware interfaces like Audio and UART Interface.

Designed with power saving technique, the current consumption of M35 is as low as 1.3 mA in SLEEP mode when DRX is 5.

M35 is integrated with Internet service protocols, such as TCP/UDP, FTP and PPP. Extended AT commands have been developed for you to use these Internet service protocols easily.

The module fully complies with the RoHS directive of the European Union.

2.2. Directives and Standards

The M35 module is designed to comply with the FCC statements. FCC ID: XMR201512M35
The Host system using M35, should have label indicated FCC ID: XMR201512M35.

2.2.1. FCC Radiation Exposure Statement

This equipment complies with FCC radiation exposure limits set forth for an uncontrolled environment.

This equipment should be installed and operated with minimum distance 20cm between the radiator and your body as well as kept minimum 20cm from radio antenna depending on the Mobile status of this

module usage. This module should NOT be installed and operating simultaneously with other radio.

The manual of the host system, which uses M35 must include RF exposure warning statement to advice user should keep minimum 20cm from the radio antenna of M35 module depending on the Mobile status.

Note: If a portable device (such as PDA) uses M35 module, the device needs to do permissive change and SAR testing.

The following list of antenna is indicating the maximum permissible antenna gain.

Part Number	Frequency Range (MHz)	Peak Gain (XZ-V)	Average Gain (XZ-V)	VSWR	Impedance
3R007A	GSM850: TX 824-849MHz RX 869-894MHz PCS1900: TX 1850-1910MHz RX 1930-1990MHz	1 dBi typ.	1 dBi typ.	3 max	50Ω

Antenna gain including cable loss must not exceed 4.95 dBi of GSM 850 and 2.5 dBi of PCS 1900 for the purpose of satisfying the requirements of 2.1043 and 2.1091. The antenna(s) used for this transmitter must be installed to provide a separation distance of at least 20cm from all persons and must not be co-located or operated in conjunction with any antenna or transmitter not described under this FCC ID. The final product operating with this transmitter must include operating instructions and antenna installation instructions, for end-users and installers to satisfy RF exposure compliance requirements. Compliance of this device in all final product configurations is the responsibility of the Grantee. Installation of this device into specific final products may require the submission of a Class II permissive change application containing data pertinent to RF Exposure, spurious emissions, ERP/EIRP, and host/module authentication, or new application if appropriate. Installation of this device into specific final products may require the submission of a Class II permissive change application containing data pertinent to RF Exposure, spurious emissions, ERP/EIRP, and host/module authentication, or new application if appropriate.

2.3. Key Features

The following table describes the detailed features of M35 module.

Table 1: Module Key Features

Feature	Implementation
---------	----------------

Power Supply	Single supply voltage: 3.3V ~ 4.6V Typical supply voltage: 4V
Power Saving	Typical power consumption in SLEEP mode: 1.3 mA @DRX=5 1.2 mA @DRX=9
Frequency Bands	<ul style="list-style-type: none"> ● Quad-band: GSM850, EGSM900, DCS1800, PCS1900 ● The module can search these frequency bands automatically ● The frequency bands can be set by AT command ● Compliant to GSM Phase 2/2+
GSM Class	Small MS
Transmitting Power	<ul style="list-style-type: none"> ● Class 4 (2W) at GSM850 and EGSM900 ● Class 1 (1W) at DCS1800 and PCS1900
GPRS Connectivity	<ul style="list-style-type: none"> ● GPRS multi-slot class 10 (default) ● GPRS multi-slot class 1~10 (configurable) ● GPRS mobile station class B
DATA GPRS	<ul style="list-style-type: none"> ● GPRS data downlink transfer: max. 85.6kbps ● GPRS data uplink transfer: max. 85.6kbps ● Coding scheme: CS-1, CS-2, CS-3 and CS-4 ● Support the protocols PAP (Password Authentication Protocol) usually used for PPP connections ● Internet service protocols : TCP/UDP/FTP/PPP/HTTP/NTP/MMS/SMTP/PING ● Support Packet Broadcast Control Channel (PBCCH) ● Support Unstructured Supplementary Service Data (USSD)
Temperature Range	<ul style="list-style-type: none"> ● Normal operation: -35°C ~ +80°C ● Restricted operation: -40°C ~ -35°C and +80°C ~ +85°C ¹⁾ ● Storage temperature: -45°C ~ +90°C
SMS	<ul style="list-style-type: none"> ● Text and PDU mode ● SMS storage: SIM card
SIM Interfaces	Support SIM card: 1.8V, 3V
Audio Features	<p>Speech codec modes:</p> <ul style="list-style-type: none"> ● Half Rate (ETS 06.20) ● Full Rate (ETS 06.10) ● Enhanced Full Rate (ETS 06.50/06.60/06.80) ● Adaptive Multi-Rate (AMR) ● Echo Suppression ● Noise Reduction ● Embedded one amplifier of class AB with maximum driving power up to 870mW
UART Interfaces	<p>UART Port:</p> <ul style="list-style-type: none"> ● Seven lines on UART port interface ● Used for AT command, GPRS data ● Multiplexing function

	<ul style="list-style-type: none"> ● Support autobauding from 4800bps to 115200bps Debug Port: <ul style="list-style-type: none"> ● Two lines on debug port interface DBG_TXD and DBG_RXD ● Debug Port can used for firmware debugging
Phonebook Management	Support phonebook types: SM, ME, FD, ON, MT
SIM Application Toolkit	Support SAT class 3, GSM 11.14 Release 99
Real Time Clock	Supported
Physical Characteristics	Size: 19.9±0.15 × 23.6±0.15 × 2.65±0.2mm Weight: Approx. 2.5g
Firmware Upgrade	Firmware upgrade via UART Port
Antenna Interface	Connected to antenna pad with 50 Ohm impedance control

NOTE

¹⁾When the module works within this temperature range, the deviations from the GSM specification may occur. For example, the frequency error or the phase error will be increased.

Table 2: Coding Schemes and Maximum Net Data Rates over Air Interface

Coding Scheme	1 Timeslot	2 Timeslot	4 Timeslot
CS-1	9.05kbps	18.1kbps	36.2kbps
CS-2	13.4kbps	26.8kbps	53.6kbps
CS-3	15.6kbps	31.2kbps	62.4kbps
CS-4	21.4kbps	42.8kbps	85.6kbps

2.4. Functional Diagram

The following figure shows a block diagram of M35 and illustrates the major functional parts.

- Radio frequency part
- Power management
- The Peripheral interface
 - Power supply

- Turn-on/off interface
- UART interfaces
- RTC interface
- Audio interfaces
- PCM interface
- SIM interfaces
- RF interface

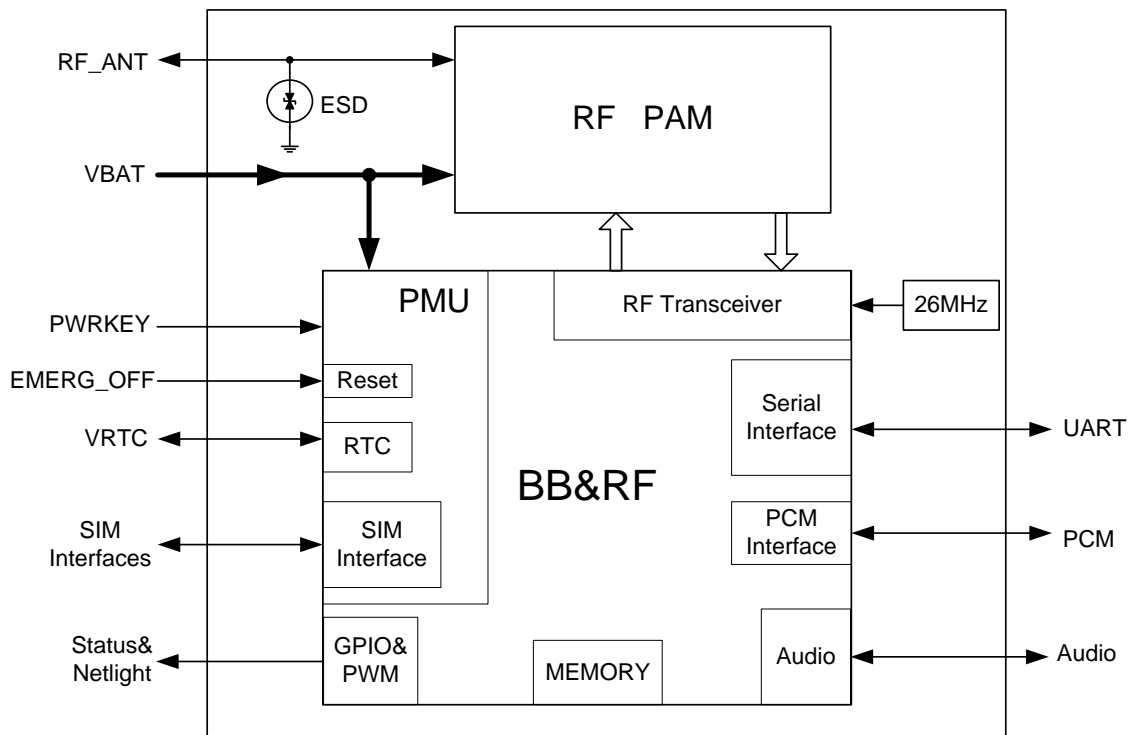

Figure 1: Module Functional Diagram

2.5. Evaluation Board

In order to help you to develop applications with M35, Quectel supplies an evaluation board (EVB), RS-232 to USB cable, power adapter, earphone, antenna and other peripherals to control or test the module. For details, please refer to the **document [4]**.

3 Application Interface

The module adopts LCC package and has 42 pins. The following chapters provide detailed descriptions about these pins below:

- Power supply
- Power on/down
- RTC
- Serial interfaces
- Audio interfaces
- PCM interface
- SIM interfaces
- RI
- NETLIGHT
- STATUS

3.1. Pin of Module

3.1.1. Pin Assignment

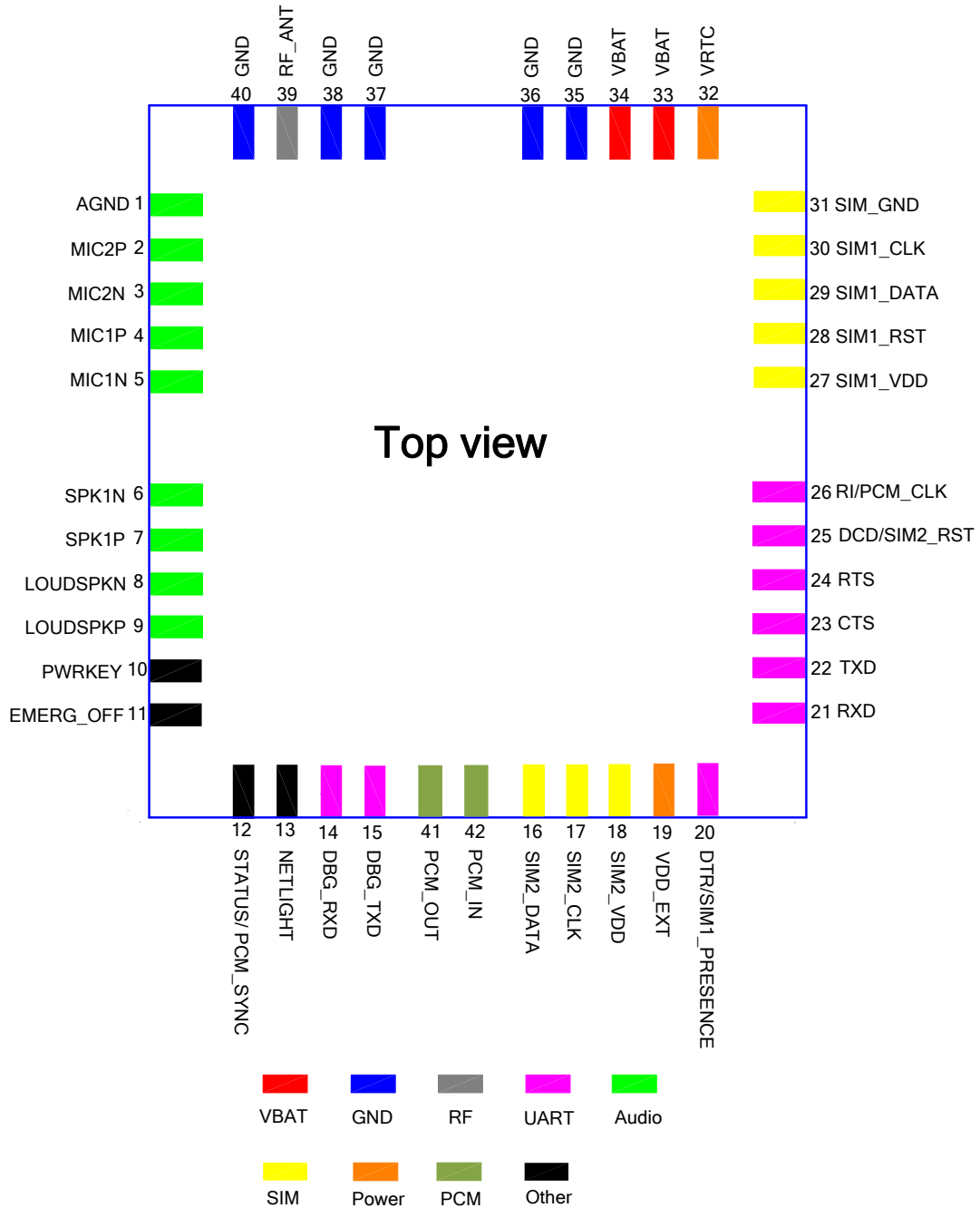

Figure 2: Pin Assignment

3.1.2. Pin Description

Table 3: Pin Description

Power Supply					
PIN NAME	PIN NO.	I/O	DESCRIPTION	DC CHARACTERISTICS	COMMENT
VBAT	33, 34	I	Main power supply of module: VBAT=3.3V~4.6V	Vmax=4.6V Vmin=3.3V Vnorm=4.0V	Make sure that supply sufficient current in a transmitting burst typically rises to 1.6A.
VRTC	32	I/O	Power supply for RTC when VBAT is not supplied for the system. Charging for backup battery or golden capacitor when the VBAT is applied.	Vlmax=3.3V Vlmin=1.5V Vlnorm=2.8V VOmax=3V VOmin=2V VOnorm=2.8V Iout(max)=2mA lin≈10uA	If unused, keep this pin open.
VDD_EXT	19	O	Supply 2.8V voltage for external circuit.	Vmax=2.9V Vmin=2.7V Vnorm=2.8V Imax=20mA	1. If unused, keep this pin open. 2. Recommend to add a 2.2~4.7uF bypass capacitor, when using this pin for power supply.
GND	35,36,37,38, 40		Ground		
Turn on/off					
PIN NAME	PIN NO.	I/O	DESCRIPTION	DC CHARACTERISTICS	COMMENT
PWRKEY	10	I	Power on/off key. PWRKEY should be pulled down for a moment to turn on or turn off the system.	Vlmax=0.1×VBAT VIHmin=0.6×VBAT Vlmax=3.1V	
Emergency Shutdown					

PIN NAME	PIN NO.	I/O	DESCRIPTION	DC CHARACTERISTICS	COMMENT
EMERG_ OFF	11	I	Emergency off. Pulled down for at least 40ms, which will turn off the module in case of emergency. Use it only when shutdown via PWRKEY or AT command cannot be achieved.	VILmax=0.45V VIHmin=1.35V Vopenmax=1.8V	Open drain/collector driver required in cellular device application. If unused, keep this pin open.

Module Indicator

PIN NAME	PIN NO.	I/O	DESCRIPTION	DC CHARACTERISTICS	COMMENT
STATUS	12	O	Indicate module's operating status. Output high level when module turns on, while output low level when module turns off.	VOHmin= 0.85×VDD_EXT VOLmax= 0.15×VDD_EXT	If unused, keep these pins open.

Audio Interfaces

PIN NAME	PIN NO.	I/O	DESCRIPTION	DC CHARACTERISTICS	COMMENT
MIC1P MIC1N	4,5	I	Channel 1 positive and negative voice input		If unused, keep these pins open.
MIC2P MIC2N	2,3	I	Channel 2 positive and negative voice input		
SPK1P SPK1N	7,6	O	Channel 1 positive and negative voice output	Refer to Section 3.8	1. If unused, keep these pins open. 2. Support both voice and ringtone output.
AGND	1		Analog ground. Separate ground connection for external audio circuits.		If unused, keep this pin open.
LOUD SPKN LOUD SPKP	8,9	O	Channel 3 positive and negative voice output		1. If unused, keep these pins open. 2. Integrate a Class- AB amplifier internally. 3. Support both voice and ringtone output.

Network Status Indicator

PIN NAME	PIN NO.	I/O	DESCRIPTION	DC CHARACTERISTICS	COMMENT
NETLIGHT	13	O	Network status indication	VOHmin= 0.85×VDD_EXT VOLmax= 0.15×VDD_EXT	If unused, keep this pin open.

UART Port

PIN NAME	PIN NO.	I/O	DESCRIPTION	DC CHARACTERISTICS	COMMENT
DTR	20	I	Data terminal ready	VILmin=0V	If only use TXD, RXD and GND to communicate, recommended connecting RTS to GND via 0R resistor and keeping other pins open.
RXD	21	I	Receive data	VILmax= 0.25×VDD_EXT	
TXD	22	O	Transmit data	VIHmin= 0.75×VDD_EXT	
RTS	24	I	Request to send	VIHmax= VDD_EXT+0.2	
CTS	23	O	Clear to send	VOHmin= 0.85×VDD_EXT	
RI	26	O	Ring indication	VOLmax= 0.15×VDD_EXT	
DCD	25	O	Data carrier detection		

Debug Port

PIN NAME	PIN NO.	I/O	DESCRIPTION	DC CHARACTERISTICS	COMMENT
DBG_TXD	15	O	Transmit data	Same as above	If unused, keep these pins open.
DBG_RXD	14	I	Receive data		

SIM Interfaces

PIN NAME	PIN NO.	I/O	DESCRIPTION	DC CHARACTERISTICS	COMMENT
SIM1_VDD	27	O	Power supply for SIM1 card	The voltage can be selected by software automatically. Either 1.8V or 3V.	All signals of SIM interfaces should be protected against ESD with a TVS diode array. Maximum trace length is 200mm from the module
SIM1_CLK	30	O	SIM1 clock	VOLmax= 0.15×SIM1_VDD VOHmin= 0.85×SIM1_VDD	

SIM1_ DATA	29	I/O	SIM1 data	VOLmax= 0.15×SIM1_VDD VOHmin= 0.85×SIM1_VDD	pad to SIM card holder.
SIM1_ RST	28	O	SIM1 reset	VOLmax= 0.15×SIM1_VDD VOHmin= 0.85×SIM1_VDD	
SIM1_ PRESENCE	20	I	SIM1 card detection.	VILmin=0V VILmax= 0.25×VDD_EXT VIHmin= 0.75×VDD_EXT VIHmax= VDD_EXT+0.2	
SIM_ GND	31		SIM ground		
SIM2_ VDD	18	O	Power supply for SIM2 card	The voltage can be selected by software automatically. Either 1.8V or 3V.	
SIM2_ CLK	17	O	SIM2 clock	VOLmax= 0.15×SIM2_VDD VOHmin= 0.85×SIM2_VDD	
SIM2_ DATA	16	I/O	SIM2 data	VOLmax= 0.15×SIM2_VDD VOHmin= 0.85×SIM2_VDD	
SIM2_ RST	25	O	SIM2 reset	VOLmax= 0.15×SIM2_VDD VOHmin= 0.85×SIM2_VDD	

RF Interface

PIN NAME	PIN NO.	I/O	DESCRIPTION	DC CHARACTERISTICS	COMMENT
RF_ANT	39	I/O	RF antenna pad	Impedance of 50Ω	

PCM Interface

PIN NAME	PIN NO.	I/O	DESCRIPTION	DC CHARACTERISTICS	COMMENT
----------	---------	-----	-------------	--------------------	---------

PCM_SYNC	12	O	PCM sync signal	VILmin=-0.3V VILmax= 0.25×VDD_EXT VIHmin= 0.75×VDD_EXT	The default function is STATUS after startup.
PCM_CLK	26	O	PCM clock signal	VIHmax= VDD_EXT+0.2 VOHmin= 0.85×VDD_EXT	The default function is RI after startup.
PCM_OUT	41	O	PCM serial data output	VOLmax= 0.15×VDD_EXT	If unused, keep these pins open.
PCM_IN	42	I	PCM serial data input		

Table 4: Multiplexed Functions

PIN NAME	PIN NO.	Function After Reset	Alternate Function ¹⁾
STATUS/PCM_SYNC	12	STATUS	PCM_SYNC
DTR/SIM1_PRESENCE	20	DTR	SIM1_PRESENCE
DCD/SIM2_RST	25	DCD	SIM2_RST
RI/PCM_CLK	26	RI	PCM_CLK

NOTE

¹⁾The alternate function can be configured through AT command. For details, please refer to the **section 3.9** and **section 3.10**.

3.2. Operating Modes

The table below briefly summarizes the various operating modes in the following chapters.

Table 5: Overview of Operating Modes

Mode	Function	
Normal Operation	GSM/GPRS Sleep	After enabling sleep mode by “AT+QSCLK=1”, the module will automatically go into Sleep Mode if DTR is set to high level and there is no interrupt (such as GPIO interrupt or data on UART port). In this case, the current consumption of module will be reduced to the minimal level. During

	Sleep Mode, the module can still receive paging message and SMS from the system normally.
GSM IDLE	Software is active. The module has registered to the GSM network, and the module is ready to send and receive GSM data.
GSM TALK	GSM connection is ongoing. In this mode, the power consumption is decided by the configuration of Power Control Level (PCL), dynamic DTX control and the working RF band.
GPRS IDLE	The module is not registered to GPRS network. The module is not reachable through GPRS channel.
GPRS STANDBY	The module is registered to GPRS network, but no GPRS PDP context is active. The SGSN knows the Routing Area where the module is located at.
GPRS READY	The PDP context is active, but no data transfer is ongoing. The module is ready to receive or send GPRS data. The SGSN knows the cell where the module is located at.
GPRS DATA	There is GPRS data in transfer. In this mode, power consumption is decided by the PCL, working RF band and GPRS multi-slot configuration.
POWER DOWN	Normal shutdown by sending the “AT+QPOWD=1” command, using the PWRKEY or the EMERG_OFF ¹⁾ pin. The power management ASIC disconnects the power supply from the base band part of the module, and only the power supply for the RTC is remained. Software is not active. The UART interfaces are not accessible. Operating voltage (connected to VBAT) remains applied.
Minimum Functionality Mode (without Removing Power Supply)	“AT+CFUN” command can set the module to a minimum functionality mode without removing the power supply. In this case, the RF part of the module will not work or the SIM card will not be accessible, or both RF part and SIM card will be disabled, but the UART port is still accessible. The power consumption in this case is very low.

NOTE

¹⁾ Use the EMERG_OFF pin only when failing to turn off the module by the command “AT+QPOWD=1” and the PWRKEY pin. For more details, please refer to the **Section 3.4.2.4**.

3.3. Power Supply

3.3.1. Power Features of Module

The power supply is one of the key issues in designing GSM terminals. Because of the 577us radio burst in GSM every 4.615ms, power supply must be able to deliver high current peaks in a burst period. During these peaks, drops on the supply voltage must not exceed minimum working voltage of module.

For M35 module, the max current consumption could reach to 1.6A during a transmit burst. It will cause a large voltage drop on the VBAT. In order to ensure stable operation of the module, it is recommended that the max voltage drop during the transmit burst does not exceed 400mV.

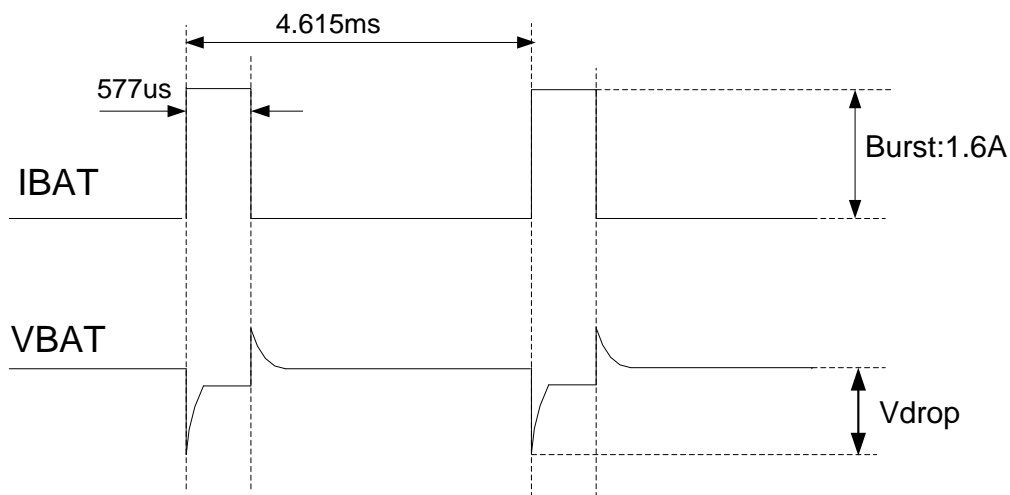

Figure 3: Voltage Ripple during Transmitting

3.3.2. Decrease Supply Voltage Drop

The power supply range of the module is 3.3V to 4.6V. Make sure that the input voltage will never drop below 3.3V even in a transmitting burst. If the power voltage drops below 3.3V, the module could turn off automatically. For better power performance, it is recommended to place a 100uF tantalum capacitor with low ESR (ESR=0.7Ω) and ceramic capacitor 100nF, 33pF and 10pF near the VBAT pin. The reference circuit is illustrated in Figure 4.

The VBAT route should be wide enough to ensure that there is not too much voltage drop during transmit burst. The width of trace should be no less than 2mm and the principle of the VBAT route is the longer route, the wider trace.

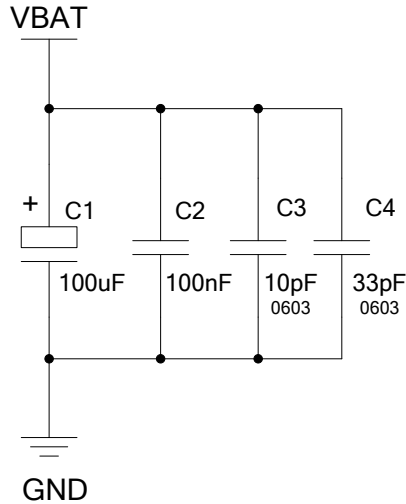

Figure 4: Reference Circuit for the VBAT Input

3.3.3. Reference Design for Power Supply

The power design for the module is very important, since the performance of power supply for the module largely depends on the power source. The power supply is capable of providing the sufficient current up to 2A at least. If the voltage drop between the input and output is not too high, it is suggested to use a LDO as module's power supply. If there is a big voltage difference between the input source and the desired output (VBAT), a switcher power converter is recommended to be used as a power supply.

Figure 5 shows a reference design for +5V input power source. The designed output for the power supply is 4.0V and the maximum load current is 3A. In addition, in order to get a stable output voltage, a zener diode is placed close to the pins of VBAT. As to the zener diode, it is suggested to use a zener diode of which reverse zener voltage is 5.1V and dissipation power is more than 1 Watt.

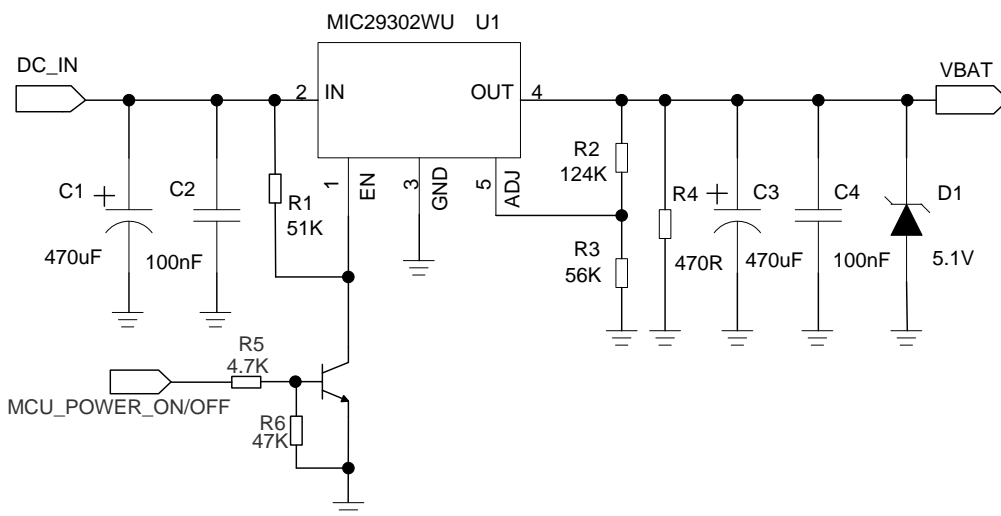

Figure 5: Reference Circuit for Power Supply

NOTE

It is suggested to control the module's main power supply (VBAT) via LDO enable pin to restart the module when the module has become abnormal. Power switch circuit like P-channel MOSFET switch circuit can also be used to control VBAT.

3.3.4. Monitor Power Supply

The command "AT+CBC" can be used to monitor the supply voltage of the module. The unit of the displayed voltage is mV.

For details, please refer to the *document [1]*.

3.4. Power On and Down Scenarios

3.4.1. Power On

The module can be turned on by driving the pin PWRKEY to a low level voltage. An open collector driver circuit is suggested to control the PWRKEY. A simple reference circuit is illustrated as below.

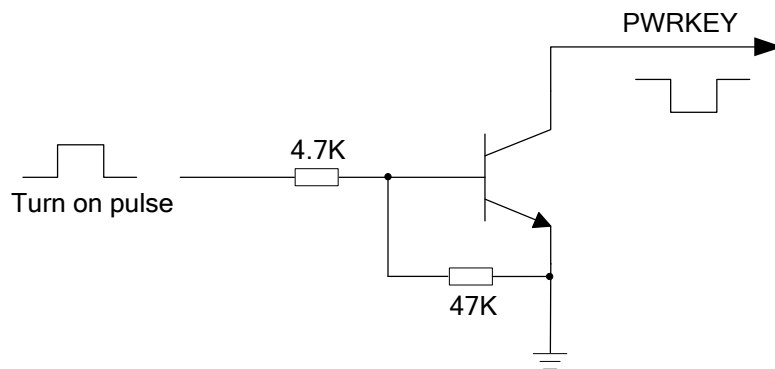

Figure 6: Turn On the Module with an Open-collector Driver

NOTE

1. M35 module is set to autobauding mode (AT+IPR=0) by default. In the autobauding mode, URC "RDY" is not reported to the host controller after module is powered on. When the module is powered on after a delay of 4 or 5 seconds, it can receive AT command. Host controller should first send an "AT" or "at" string in order that the module can detect baud rate of host controller, it should continue to send the next "AT" string until receiving "OK" string from the module. Then enter "AT+IPR=x;&W" to set a fixed baud rate for the module and save the configuration to flash memory of the module. After

these configurations, the URC “RDY” would be received from the UART Port of the module every time when the module is powered on. For more details, refer to the section “AT+IPR” in **document [1]**.

2. AT command response indicates module is turned on successfully, or else the module fails to be turned on.

The other way to control the PWRKEY is through a button directly. A TVS component is indispensable to be placed nearby the button for ESD protection. For the best performance, the TVS component must be placed nearby the button. When pressing the key, electrostatic strike may generate from finger. A reference circuit is shown in the following figure.

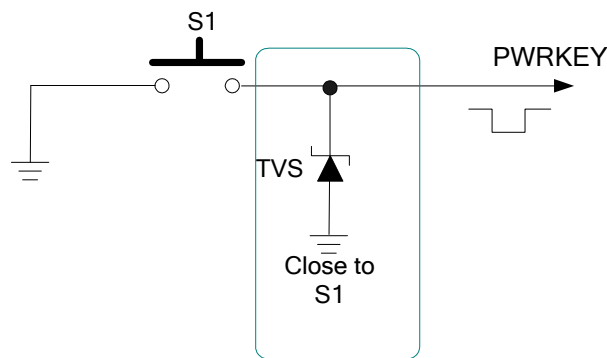

Figure 7: Turn On the Module with a Button

The turn-on timing is illustrated as the following figure.

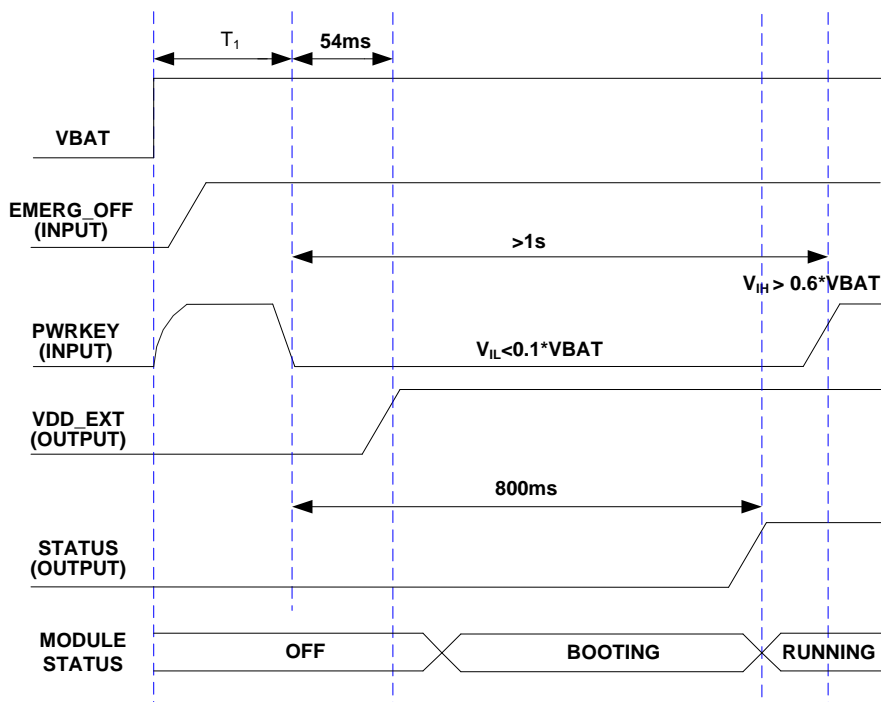

Figure 8: Turn-on Timing

NOTE

1. Make sure that VBAT is stable before pulling down PWRKEY pin. The time of T_1 is recommended as 100ms.
2. EMERG_OFF should be floated when it is unused.
3. For more details about the application of STATUS pin, please refer to the **Chapter 3.13**.

3.4.2. Power Down

The following procedures can be used to turn off the module:

- Normal power down procedure: Turn off module using the PWRKEY pin.
- Normal power down procedure: Turn off module using command “AT+QPOWD=1”.
- Over-voltage or under-voltage automatic shutdown: Take effect when over-voltage or under-voltage is detected.
- Emergent power down procedure: Turn off module using the EMERG_OFF pin.

3.4.2.1. Power Down Module Using the PWRKEY Pin

It is a safe way to turn off the module by driving the PWRKEY to a low level voltage for a certain time. The power down scenario is illustrated in Figure 9.

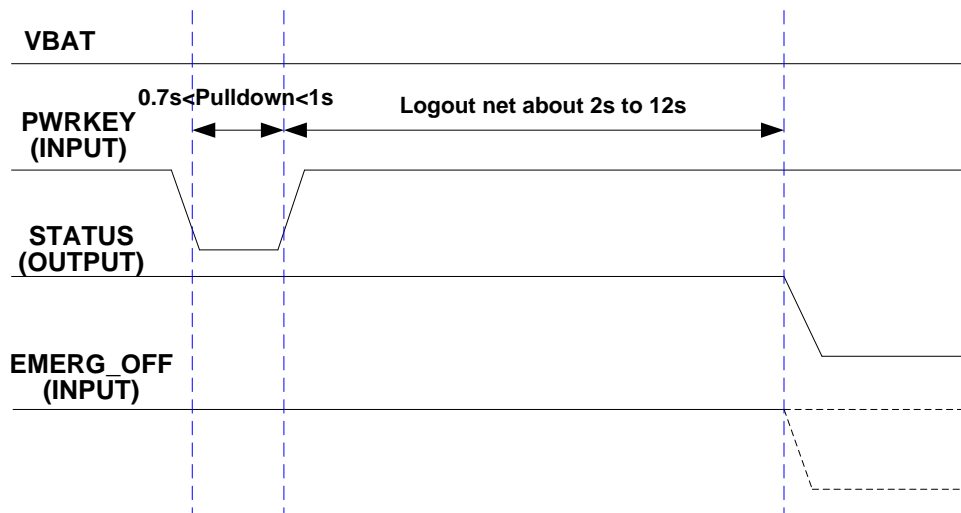

Figure 9: Turn-off Timing

The power down procedure causes the module to log off from the network and allows the firmware to save important data before completely disconnecting the power supply.

Before the completion of the power down procedure, the module sends out the result code shown below:

NORMAL POWER DOWN

NOTE

1. This result code does not appear when autobauding is active and DTE and DCE are not correctly synchronized after start-up. The module is recommended to set a fixed baud rate.
2. As logout network time is related to the local mobile network, it is recommended to delay about 12 seconds before disconnecting the power supply or restarting the module.
3. For more details about the application of STATUS pin, please refer to the **Chapter 3.13**.

After that moment, no further AT commands can be executed. Then the module enters the power down mode, only the RTC is still active.

3.4.2.2. Power Down Module Using AT Command

It is also a safe way to turn off the module via AT command “AT+QPOWD=1”. This command will let the module to log off from the network and allow the firmware to save important data before completely disconnecting the power supply.

Before the completion of the power down procedure, the module sends the result code as shown below:

NORMAL POWER DOWN

After that moment, no further AT commands can be executed. And then the module enters the power down mode, only the RTC is still active.

Please refer to the **document [1]** for details about the AT command “AT+QPOWD”.

3.4.2.3. Over-voltage or Under-voltage Automatic Shutdown

The module will constantly monitor the voltage applied on the VBAT, if the voltage is $\leq 3.5V$, the following URC will be presented:

UNDER_VOLTAGE WARNING

If the voltage is $\geq 4.5V$, the following URC will be presented:

OVER_VOLTAGE WARNING

The normal input voltage range is from 3.3V to 4.6V. If the voltage is >4.6V or <3.3V, the module would automatically shut down itself.

If the voltage is <3.3V, the following URC will be presented:

UNDER_VOLTAGE POWER DOWN

If the voltage is >4.6V, the following URC will be presented:

OVER_VOLTAGE POWER DOWN

After that moment, no further AT commands can be executed. The module logs off from network and enters power down mode, and only RTC is still active.

NOTE

1. These result codes do not appear when autobauding is active and DTE and DCE are not correctly synchronized after start-up. The module is recommended to set to a fixed baud rate.
2. Over-voltage warning and shutdown function is disabled by default.

3.4.2.4. Emergency Shutdown Using EMERG_OFF Pin

The module can be shut down by driving the pin EMERG_OFF to a low level voltage over 40ms and then releasing it. The EMERG_OFF line can be driven by an open-drain/collector driver or a button. The circuit is illustrated as the following figures.

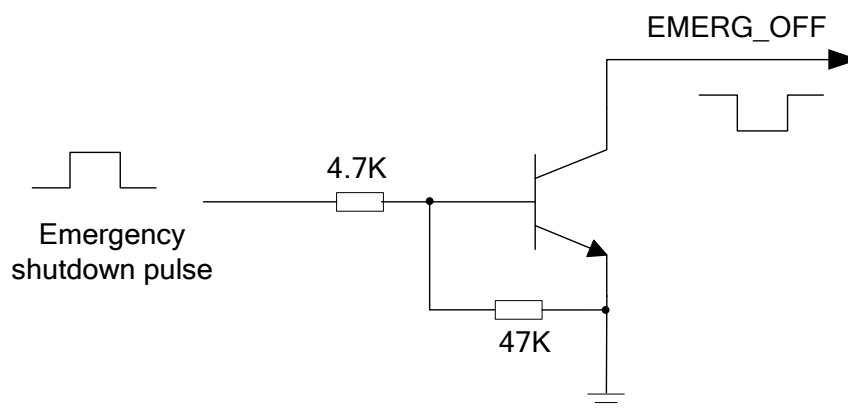

Figure 10: An Open-collector Driver for EMERG_OFF

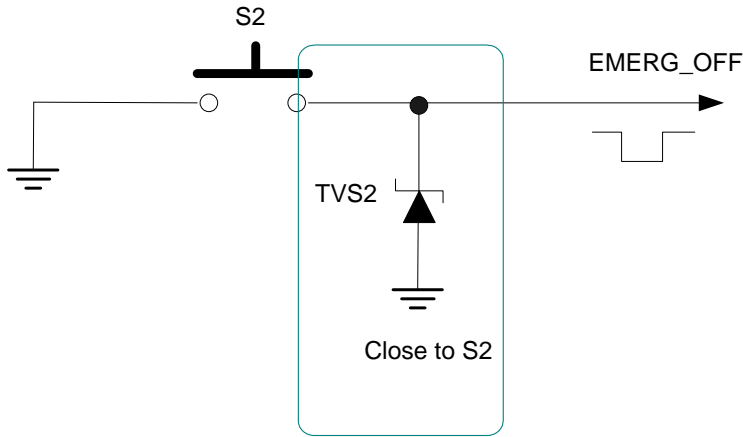

Figure 11: Reference Circuit for EMERG_OFF by Using Button

Be cautious to use the pin EMERG_OFF. It should only be used under emergent situation. For instance, if the module is unresponsive or abnormal, the pin EMERG_OFF could be used to shut down the system. Although turning off the module by EMERG_OFF is fully tested and nothing wrong detected, this operation is still a big risk as it could cause destroying of the code or data area of the flash memory in the module. Therefore, it is recommended that PWRKEY or AT command should always be the preferential way to turn off the system.

3.4.3. Restart

The module can be restarted by driving the PWRKEY to a low level voltage for a certain time, which is similar to the way of turning on module. In order to make the internal LDOs discharge completely after turning off the module, it is recommended to delay about 500ms before restarting the module. The restart timing is illustrated as the following figure.

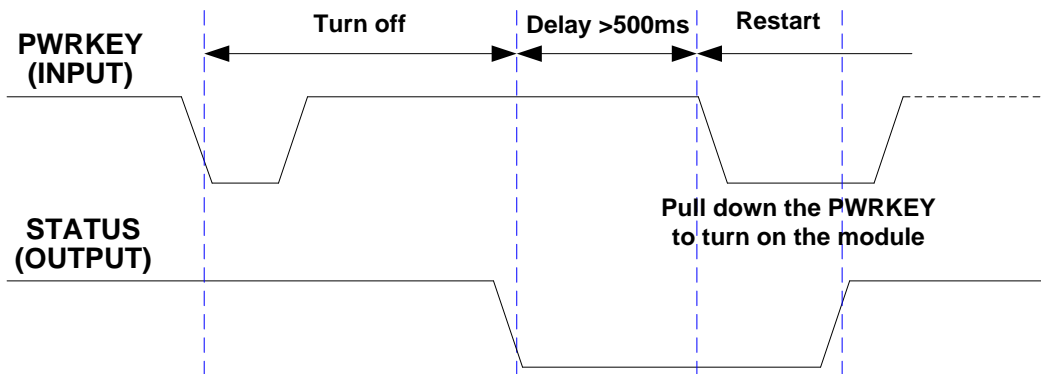

Figure 12: Timing of Restarting System

The module can also be restarted by the PWRKEY after emergency shutdown.

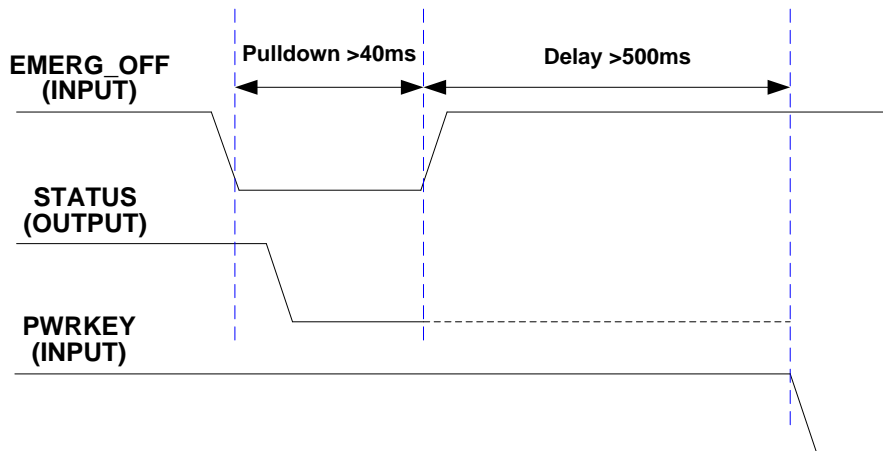

Figure 13: Timing of Restarting System after Emergency Shutdown

NOTE

For more details about the application of STATUS pin, please refer to the **Chapter 3.13**.

3.5. Power Saving

Based on system requirements, there are several actions to drive the module to enter low current consumption status. For example, “AT+CFUN” can be used to set module into minimum functionality mode and DTR hardware interface signal can be used to lead system to SLEEP mode.

3.5.1. Minimum Functionality Mode

Minimum functionality mode reduces the functionality of the module to a minimum level. The consumption of the current can be minimized when the slow clocking mode is activated at the same time. The mode is set with the “AT+CFUN” command which provides the choice of the functionality levels <fun>=0, 1, 4.

- 0: minimum functionality.
- 1: full functionality (default).
- 4: disable both transmitting and receiving of RF part.

If the module is set to minimum functionality by “AT+CFUN=0”, the RF function and SIM card function would be disabled. In this case, the UART port is still accessible, but all AT commands related with RF function or SIM card function will be not available.

If the module has been set by the command with “AT+CFUN=4”, the RF function will be disabled, but the UART port is still active. In this case, all AT commands related with RF function will be not available.

After the module is set by “AT+CFUN=0” or “AT+CFUN=4”, it can return to full functionality by “AT+CFUN=1”.

For detailed information about “AT+CFUN”, please refer to the **document [1]**.

3.5.2. SLEEP Mode

The SLEEP mode is disabled by default. You can enable it by “AT+QSCLK=1”. On the other hand, the default setting is “AT+QSCLK=0” and in this mode, the module cannot enter SLEEP mode.

When the module is set by the command with “AT+QSCLK=1”, you can control the module to enter or exit from the SLEEP mode through pin DTR. When DTR is set to high level, and there is no on-air or hardware interrupt such as GPIO interrupt or data on UART port, the module will enter SLEEP mode automatically. In this mode, the module can still receive voice, SMS or GPRS paging from network, but the UART port does not work.

3.5.3. Wake Up Module from SLEEP Mode

When the module is in the SLEEP mode, the following methods can wake up the module.

- If the DTR Pin is set low, it would wake up the module from the SLEEP mode. The UART port will be active within 20ms after DTR is changed to low level.
- Receiving a voice or data call from network will wake up the module.
- Receiving an SMS from network will wake up the module.

NOTE

DTR pin should be held at low level during communication between the module and DTE.

3.5.4. Summary of State Transition

Table 6: Summary of State Transition

Current Mode	Next Mode		
	Power Down	Normal Mode	Sleep Mode
Power Down		Use PWRKEY	
Normal Mode	AT+QPOWD, use PWRKEY pin, or use EMERG_OFF pin		Use AT command "AT+QSCLK=1" and pull DTR up
SLEEP Mode	Use PWRKEY pin, or use EMERG_OFF pin	Pull DTR down or incoming voice call or SMS or data call	

3.6. RTC Backup

The RTC (Real Time Clock) function is supported. The RTC is designed to work with an internal power supply.

There are three kinds of designs for RTC backup power:

- Use VBAT as the RTC power source.

When the module is turned off and the main power supply (VBAT) is remained, the real time clock is still active as the RTC core is supplied by VBAT. In this case, the VRTC pin can be kept floating.

- Use VRTC as the RTC power source.

If the main power supply (VBAT) is removed after the module is turned off, a backup supply such as a coin-cell battery (rechargeable or non-chargeable) or a super-cap can be used to supply the VRTC pin to keep the real time clock active.

- Use VBAT and VRTC as the RTC power source.

As only powering the VRTC pin to keep the RTC will lead an error about 5 minutes a day, it is recommended to power VBAT and VRTC pin at the same time when RTC function is needed. The recommended supply for RTC core circuits are shown as below.

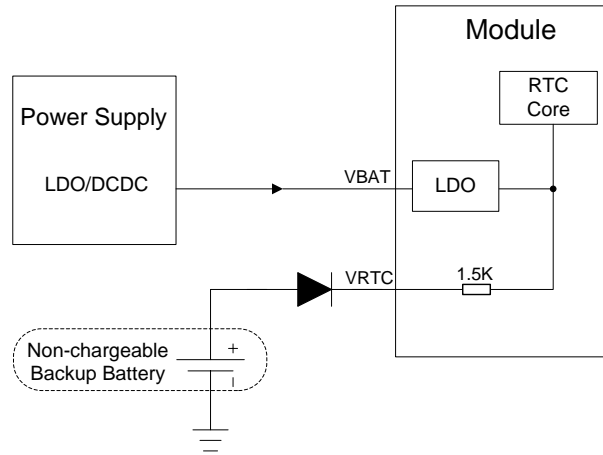

Figure 14: VRTC Is Supplied by a Non-chargeable Battery

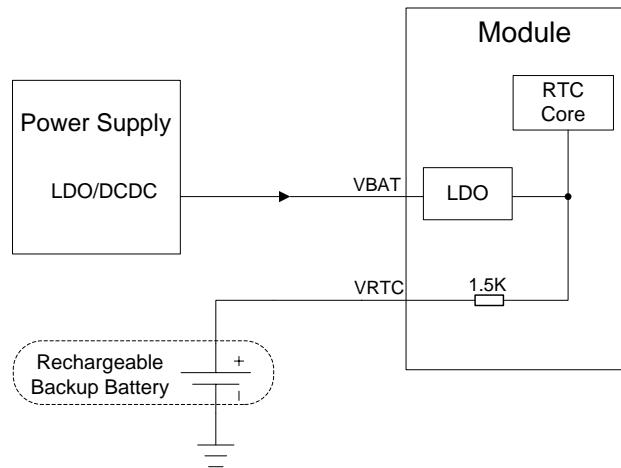

Figure 15: VRTC Is Supplied by a Rechargeable Battery

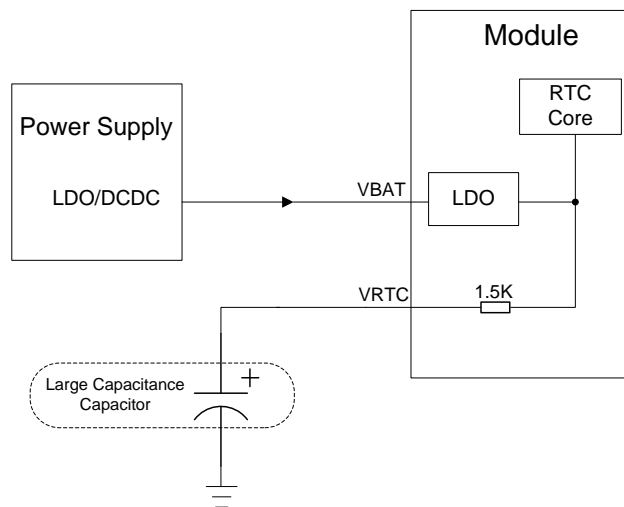

Figure 16: VRTC Is Supplied by a Capacitor

For the choice of a rechargeable or non-chargeable coin-cell battery, please visit <http://www.sii.co.jp/en/>.

NOTE

If the module is only powered by VRTC , the real time will have an error about 5 minutes a day. If you want to keep an accurate real time, please use VBAT to supply the RTC core.

3.7. Serial Interfaces

The module provides two serial ports: UART Port and Debug Port. The module is designed as a DCE (Data Communication Equipment), following the traditional DCE-DTE (Data Terminal Equipment) connection. Autobauding function supports baud rate from 4800bps to 115200bps.

The UART Port:

- TXD: Send data to RXD of DTE.
- RXD: Receive data from TXD of DTE.
- RTS: Request to send.
- CTS: Clear to send.
- DTR: DTE is ready and inform DCE (this pin can wake up the module).
- RI: Ring indicator (when the call, SMS, data of the module are coming, the module will output signal to inform DTE).
- DCD: Data carrier detection (the validity of this pin demonstrates the communication link is set up).

NOTE

Hardware flow control is disabled by default. When hardware flow control is required, RTS and CTS should be connected to the host. AT command "AT+IFC=2,2" is used to enable hardware flow control. AT command "AT+IFC=0,0" is used to disable the hardware flow control. For more details, please refer to the **document [1]**.

The Debug Port:

- DBG_TXD: Send data to the COM port of computer.
- DBG_RXD: Receive data from the COM port of computer.

The logic levels are described in the following table.

Table 7: Logic Levels of the UART Interfaces

Parameter	Min.	Max.	Unit
V_{IL}	0	$0.25 \times VDD_EXT$	V
V_{IH}	$0.75 \times VDD_EXT$	$VDD_EXT + 0.2$	V
V_{OL}	0	$0.15 \times VDD_EXT$	V
V_{OH}	$0.85 \times VDD_EXT$	VDD_EXT	V

Table 8: Pin Definition of the UART Interfaces

Interfaces	Pin No.	Pin Name	Description	Alternate Function
Debug Port	14	DBG_RXD	Receive data	
	15	DBG_TXD	Transmit data	
UART Port	20	¹⁾ DTR	Data terminal ready	SIM1_PRESENCE
	21	RXD	Receive data	
	22	TXD	Transmit data	
	23	CTS	Clear to send	
	24	RTS	Request to send	
	25	²⁾ DCD	Data carrier detection	SIM2_RST
	26	³⁾ RI	Ring indication	PCM_CLK

NOTE

- ¹⁾ DTR pin can be used as SIM1_PRESENCE pin via “AT+QSIMDET” command.
- ²⁾ When using the SIM2 interface, DCD pin can be used as SIM2_RST pin. For more details, please refer to the **document [6]**.
- ³⁾ When using the PCM interface, RI pin can be used as PCM_CLK.

3.7.1. UART Port

3.7.1.1. The Features of UART Port

- Seven lines on UART interface.
- Contain data lines TXD and RXD, hardware flow control lines RTS and CTS, other control lines DTR, DCD and RI.
- Used for AT command, GPRS data, etc. Multiplexing function is supported on the UART Port. So far only the basic mode of multiplexing is available.
- Support the communication baud rates as the following:
300, 600, 1200, 2400, 4800, 9600, 14400, 19200, 28800, 38400, 57600 and 115200.
- The default setting is autobauding mode. Support the following baud rates for Autobauding function:
4800, 9600, 19200, 38400, 57600 and 115200.
- The module disables hardware flow control by default. AT command "AT+IFC=2,2" is used to enable hardware flow control.

After setting a fixed baud rate or autobauding, please send "AT" string at that rate. The UART port is ready when it responds "OK".

Autobauding allows the module to detect the baud rate by receiving the string "AT" or "at" from the host or PC automatically, which gives module flexibility without considering which baud rate is used by the host controller. Autobauding is enabled by default. To take advantage of the autobauding mode, special attention should be paid according to the following requirements:

1. Synchronization between DTE and DCE:

When DCE (the module) powers on with the autobauding enabled, it is recommended to wait 4 to 5 seconds before sending the first AT character. After receiving the "OK" response, DTE and DCE are correctly synchronized.

If the host controller needs URC in the mode of autobauding, it must be synchronized firstly. Otherwise the URC will be discarded.

2. Restrictions on autobauding operation:

- The UART port has to be operated at 8 data bits, no parity and 1 stop bit (factory setting).
- Only the strings "AT" or "at" can be detected (neither "At" nor "aT").
- The Unsolicited Result Codes like "RDY", "+CFUN: 1" and "+CPIN: READY" will not be indicated when the module is turned on with autobauding enabled and not be synchronized.
- Any other Unsolicited Result Codes will be sent at the previous baud rate before the module detects the new baud rate by receiving the first "AT" or "at" string. The DTE may receive unknown characters after switching to new baud rate.
- It is not recommended to switch to autobauding from a fixed baud rate.

- If autobauding is active it is not recommended to switch to multiplex mode.

NOTE

To assure reliable communication and avoid any problems caused by undetermined baud rate between DCE and DTE, it is strongly recommended to configure a fixed baud rate and save it instead of using autobauding after start-up. For more details, please refer to the Section “AT+IPR” in **document [1]**.

3.7.1.2. The Connection of UART

The connection between module and host using UART Port is very flexible. Three connection styles are illustrated as below.

Reference design for Full-Function UART connection is shown as below when it is applied in modulation-demodulation.

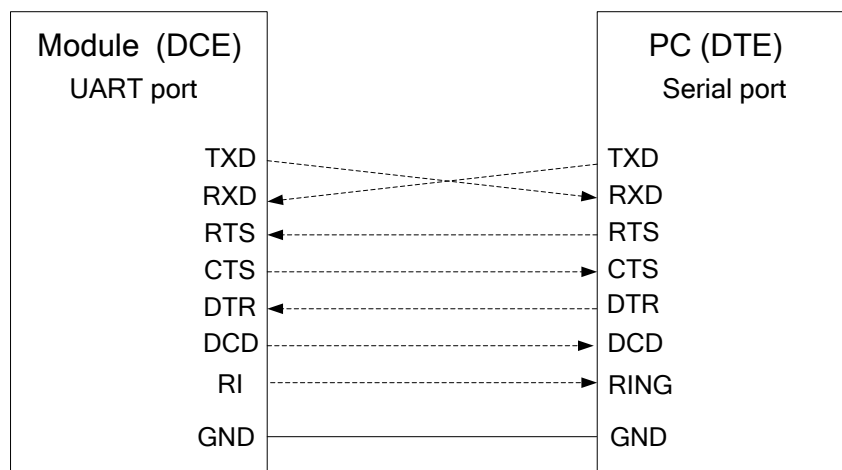

Figure 17: Reference Design for Full-Function UART

Three-line connection is shown as below.

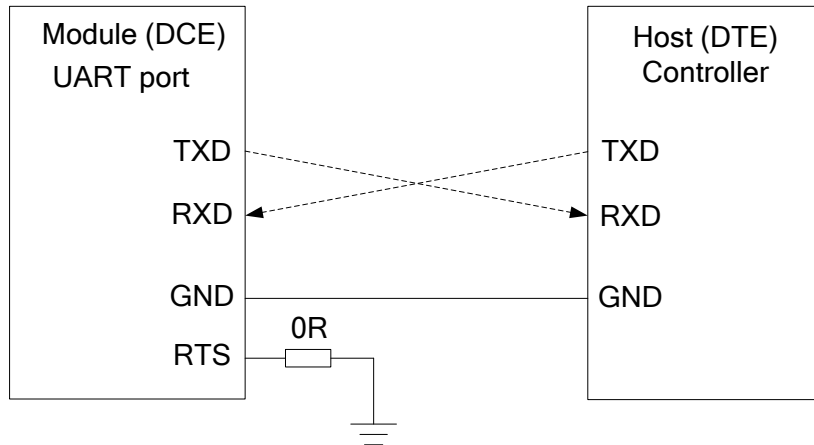

Figure 18: Reference Design for UART Port

UART Port with hardware flow control is shown as below. This connection will enhance the reliability of the mass data communication.

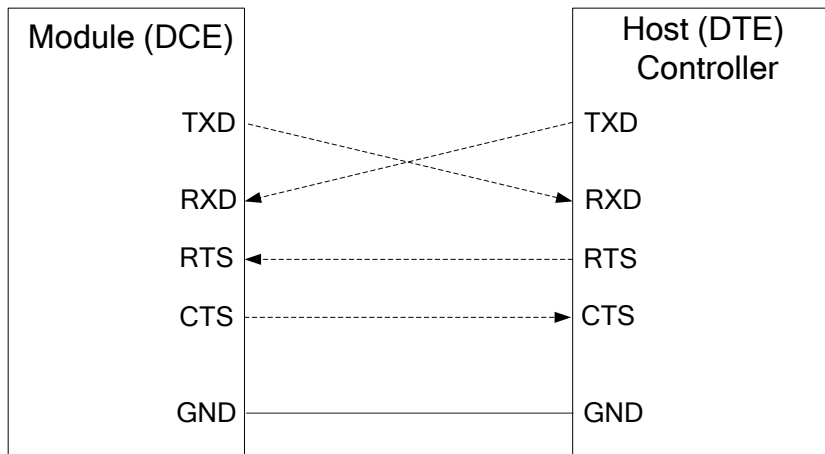

Figure 19: Reference Design for UART Port with Hardware Flow Control

3.7.1.3. Firmware Upgrade

The TXD, RXD can be used to upgrade firmware. The PWRKEY pin must be pulled down before firmware upgrade. The reference circuit is shown as below:

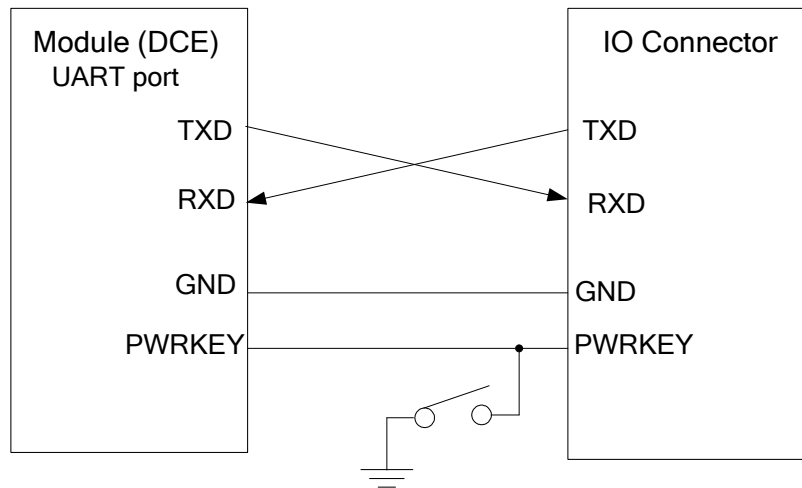

Figure 20: Reference Design for Firmware Upgrade

NOTE

The firmware of module might need to be upgraded due to certain reasons. It is recommended to reserve these pins in the host board for firmware upgrade.

3.7.2. Debug Port

As to Debug Port, there are two working modes, Standard Mode and Advanced Mode, which can be switched through using AT command" AT+QEAUART". For more details, please refer to the **document [7]**.

In Standard Mode, it can be used to execute software debug and it can also connect to a peripheral device. Furthermore, its default baud rate is 115200bps.

In Advanced Mode, it can only be used to execute software debug, capture the system's log with Cather Log tool and output the log. In this mode, its baud rate is 460800bps.

The reference design for Debug Port is shown as below.

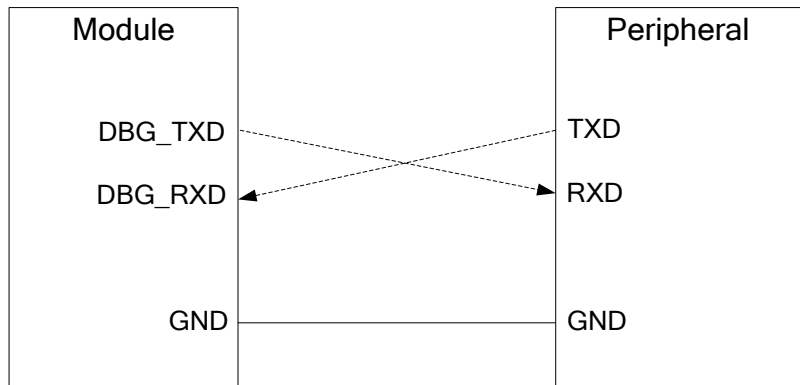

Figure 21: Reference Design for Debug Port

3.7.3. UART Application

The reference design of 3.3V level match is shown as below. If the host is a 3V system, please change the 5.6K resistor to 10K.

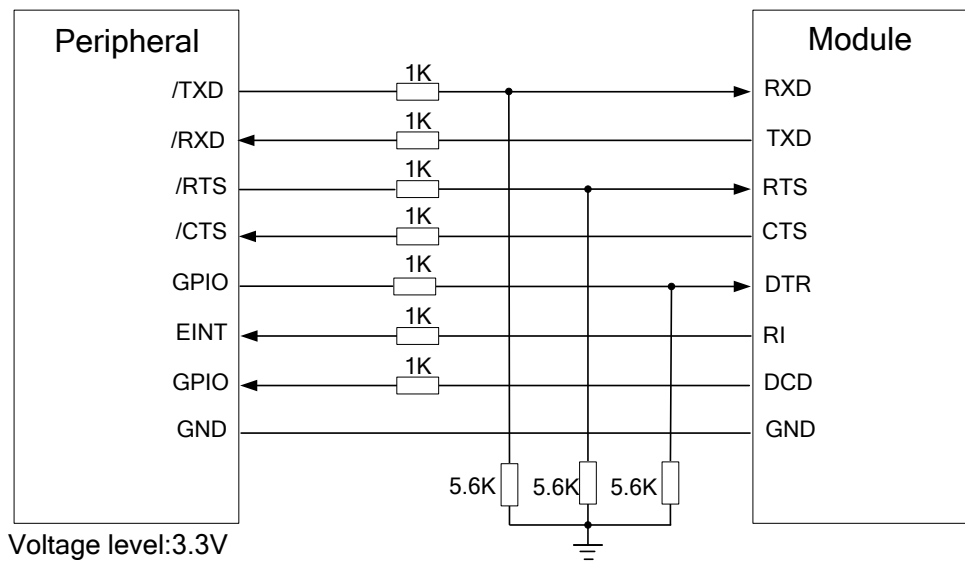

Figure 22: Level Match Design for 3.3V System

NOTE

It is highly recommended to add the resistor divider circuit on the UART signal lines when the host's level is 3V or 3.3V. For the higher voltage level system, a level shifter IC could be used between the host and the module. For more details about UART circuit design, please refer to **document [8]**.

The following circuit shows a reference design for the communication between module and PC. Since the electrical level of module is 2.8V, so a RS-232 level shifter must be used. Note that you should assure the IO voltage of level shifter which connects to module is 2.8V.

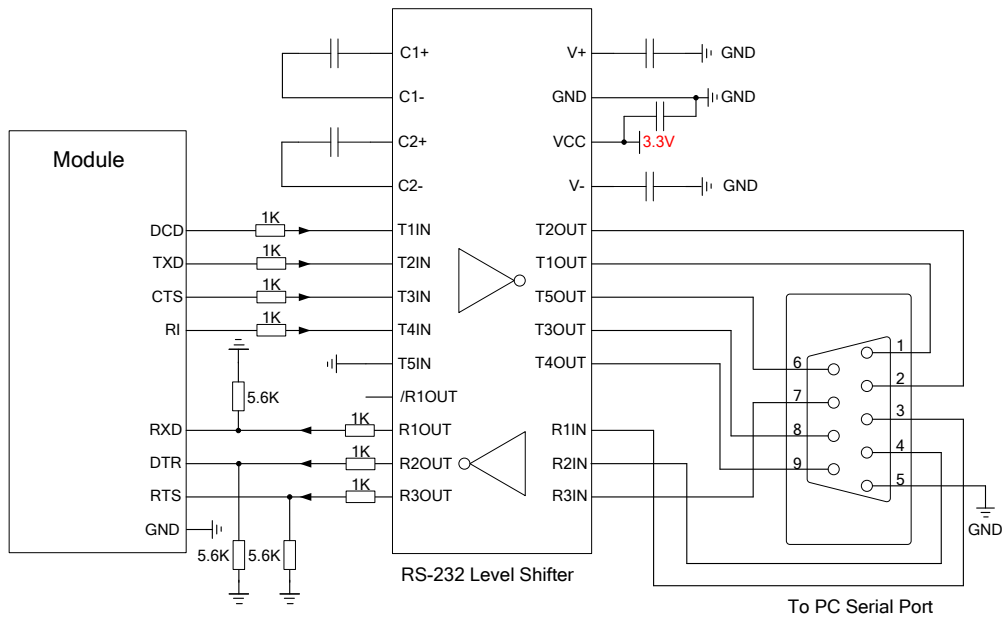

Figure 23: Sketch Map for RS-232 Interface Match

Please visit vendor web site to select the suitable RS-232 level shifter IC, such as: <http://www.exar.com/> and <http://www.maximintegrated.com>.

3.8. Audio Interfaces

The module provides two analogy input channels and two analogy output channels.

Table 9: Pin Definition of Audio Interface

Interfaces	Name	Pin NO.	Description
AIN1/AOUT1	MIC1P	4	Channel 1 Microphone positive input
	MIC1N	5	Channel 1 Microphone negative input
	SPK1P	7	Channel 1 Audio positive output
	SPK1N	6	Channel 1 Audio negative output
AIN2/AOUT2	AGND	1	Form a pseudo-differential pair with SPK2P

MIC2P	2	Channel 2 Microphone positive input
MIC2N	3	Channel 2 Microphone negative input
LOUDSPKP	9	Channel 2 Audio positive output
LOUDSPKN	8	Channel 2 Audio negative output

AIN1 and AIN2 can be used for input of microphone and line. An electret microphone is usually used. AIN1 and AIN2 are both differential input channels.

AOUT1 is used for output of the receiver. This channel is typically used for a receiver built into a handset. AOUT1 channel is a differential channel. If it is used as a speaker, an amplifier should be employed.

AOUT2 is used for loudspeaker output as it embedded an amplifier of class AB whose maximum drive power is 870mW. AOUT2 is a differential channel.

AOUT2 also can be used for output of earphone, which can be used as a single-ended channel. LOUDSPKP and AGND can establish a pseudo differential mode.

All of these two audio channels support voice and ringtone output, and so on, and can be switched by “AT+QAUDCH” command. For more details, please refer to the **document [1]**.

Use AT command “AT+QAUDCH” to select audio channel:

- 0--AIN1/AOUT1, the default value is 0.
- 1--AIN2/AOUT2, this channel is always used for earphone.
- 2--AIN2/AOUT2, this channel is always used for loudspeaker.

For each channel, you can use AT+QMIC to adjust the input gain level of microphone. You can also use “AT+CLVL” to adjust the output gain level of receiver and speaker. “AT+QSIDET” is used to set the side-tone gain level. For more details, please refer to the **document [1]**.

Table 10: AOUT2 Output Characteristics

Item	Condition	Min.	Type	Max.	Unit
RMS Power	8ohm load VBAT=4.2v THD+N=1%		870		mW
	8ohm load VBAT=3.3v THD+N=1%		530		mW

3.8.1. Decrease TDD Noise and Other Noise

The 33pF capacitor is applied for filtering out 900MHz RF interference when the module is transmitting at EGSM900MHz. Without placing this capacitor, TDD noise could be heard. Moreover, the 10pF capacitor here is for filtering out 1800MHz RF interference. However, the resonant frequency point of a capacitor largely depends on the material and production technique. Therefore, you would have to discuss with its capacitor vendor to choose the most suitable capacitor for filtering out GSM850MHz, EGSM900MHz, DCS1800MHz and PCS1900MHz separately.

The severity degree of the RF interference in the voice channel during GSM transmitting period largely depends on the application design. In some cases, EGSM900 TDD noise is more severe; while in other cases, DCS1800 TDD noise is more obvious. Therefore, you can have a choice based on test results. Sometimes, even no RF filtering capacitor is required.

The capacitor which is used for filtering out RF noise should be close to audio interface. Audio alignment should be as short as possible.

In order to decrease radio or other signal interference, the position of RF antenna should be kept away from audio interface and audio alignment. Power alignment and audio alignment should not be parallel, and power alignment should be far away from audio alignment.

The differential audio traces have to be placed according to the differential signal layout rule.

3.8.2. Microphone Interfaces Design

AIN1 and AIN2 channels come with internal bias supply for external electret microphone. A reference circuit is shown in the following figure.

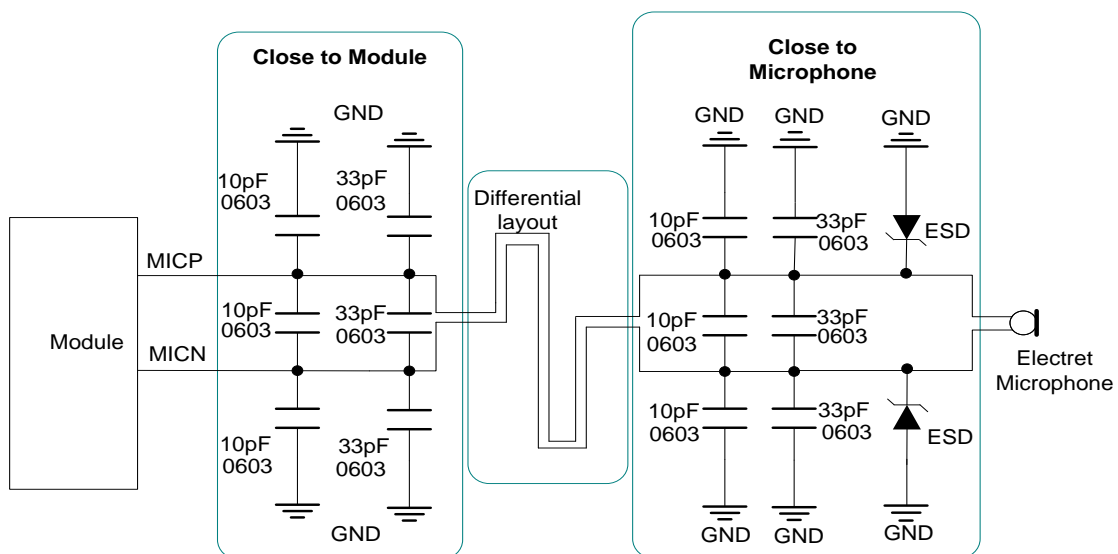

Figure 24: Reference Design for AIN1&AIN2

3.8.3. Receiver Interface Design

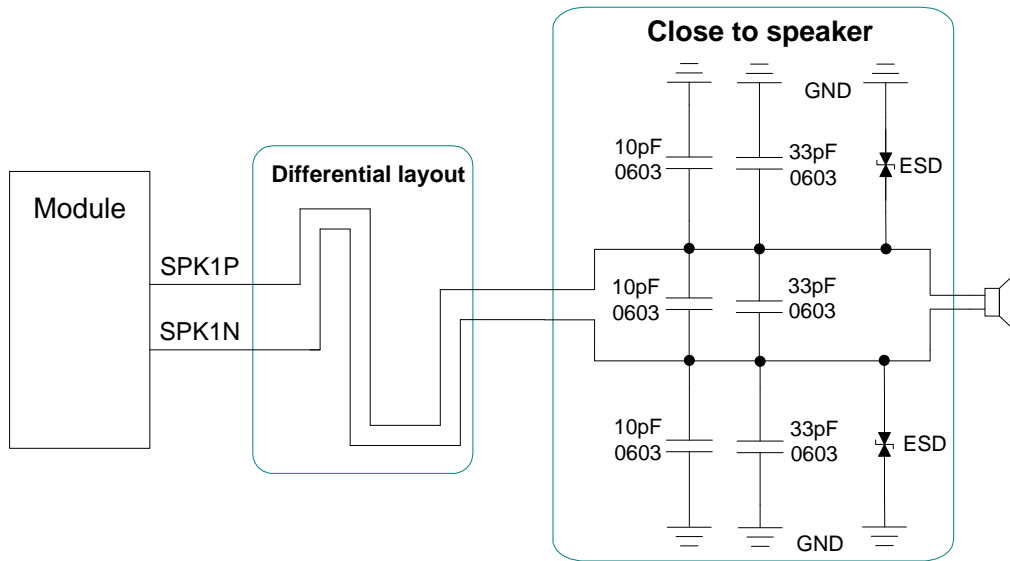

Figure 25: Reference Interface Design of AOUT1

3.8.4. Earphone Interface Design

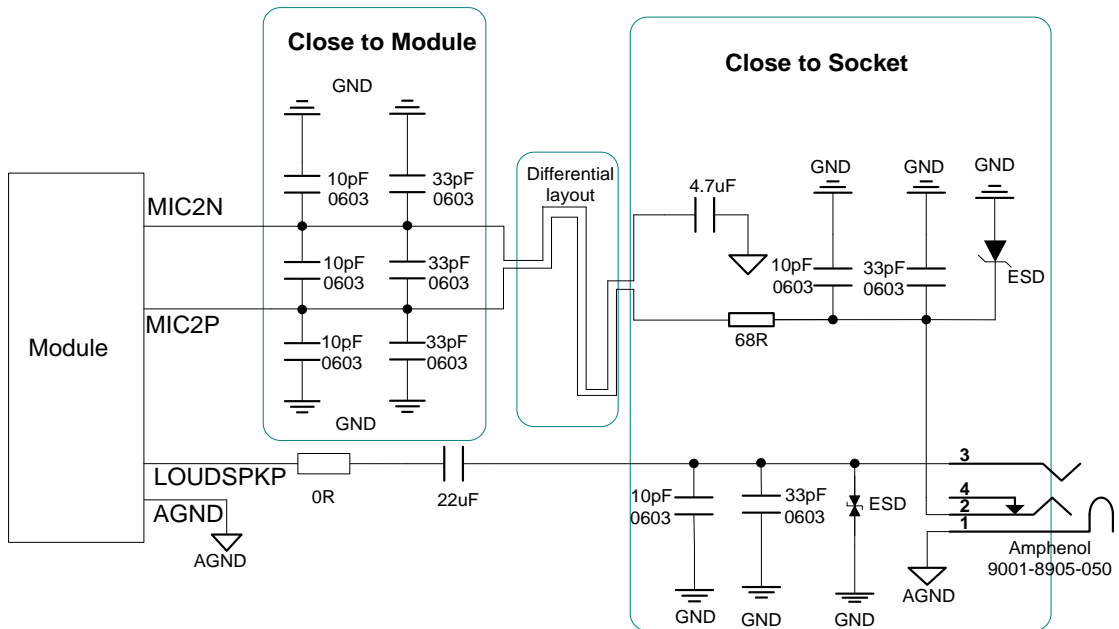

Figure 26: Earphone Interface Design

3.8.5. Loud Speaker Interface Design

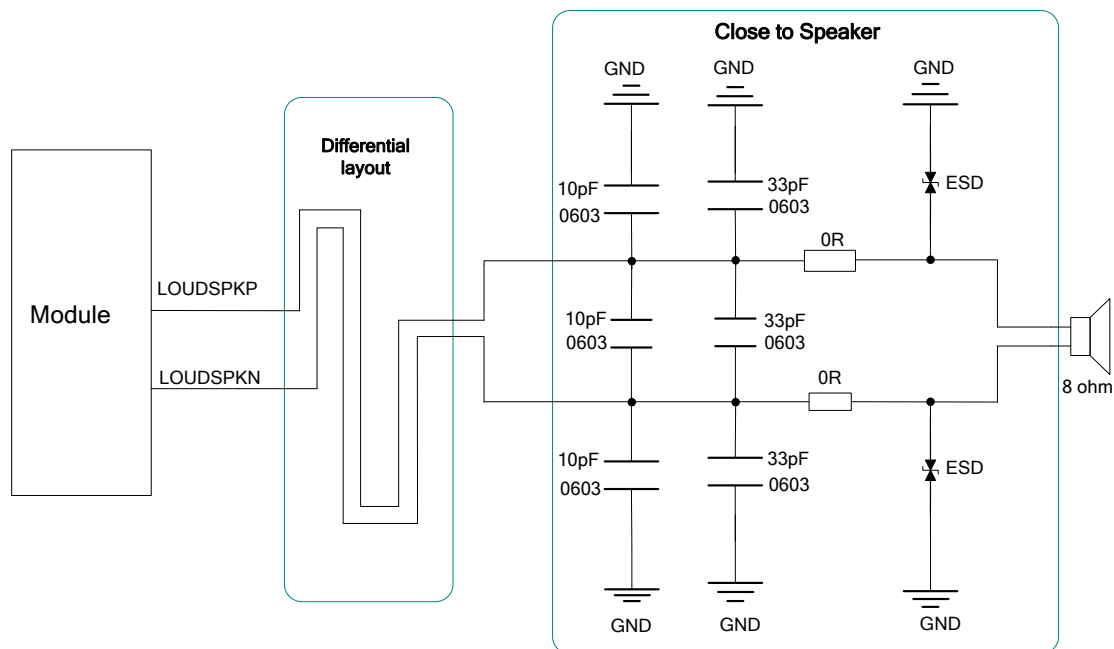

Figure 27: Loud Speaker Interface Design

3.8.6. Audio Characteristics

Table 11: Typical Electret Microphone Characteristics

Parameter	Min.	Typ.	Max.	Unit
Working Voltage	1.2	1.5	2.0	V
Working Current	200		500	uA
External Microphone Load Resistance		2.2		k Ohm

Table 12: Typical Speaker Characteristics

Parameter	Min.	Typ.	Max.	Unit
AOUT1 Output	Single-ended	Load resistance	32	Ohm
		Ref level	0	2.4
	Differential	Load resistance	32	Ohm

		Ref level	0	4.8	Vpp
AOUT2 Output	Differential	Load resistance	8		Load Resistance
		Reference level	0	2×VBAT	Vpp
	Single-ended	Load resistance	8		Load Resistance
		Reference level	0	VBAT	Vpp

3.9. PCM Interface

Pulse-code modulation (PCM) is a converter that changes the consecutive analog audio signal to discrete digital signal. The whole procedure of Pulse-code modulation contains sampling, quantizing and encoding.

M35 supports PCM interface. It is used for digital audio transmission between the module and the device. This interface is composed of PCM_CLK, PCM_SYNC, PCM_IN and PCM_OUT signal lines.

The module disables PCM interface by default. AT command “AT+QPCMON” is used to configure PCM interface.

Table 13: Pin Definition of PCM Interface

Pin NO.	Pin Name	Description	¹⁾ Alternate Function
12	PCM_SYNC	PCM frame synchronization output	STATUS
26	PCM_CLK	PCM clock output	RI
41	PCM_OUT	PCM data output	
42	PCM_IN	PCM data input	

NOTE

¹⁾When using the PCM interface, STATUS pin can be used as PCM_SYNC pin, RI pin can be used as PCM_CLK pin.

3.9.1. Configuration

M35 module supports 13-bit line code PCM format. The sample rate is 8 KHz, and the clock source is 256 KHz, and the module can only act as master mode. The PCM interface supports both long and short synchronization simultaneously. Furthermore, it only supports MSB first. For detailed information, please refer to the table below.

Table 14: Configuration

PCM	
Line Interface Format	Linear
Data Length	Linear: 13 bits
Sample Rate	8KHz
PCM Clock/Synchronization Source	PCM master mode: clock and synchronization is generated by module
PCM Synchronization Rate	8KHz
PCM Clock Rate	PCM master mode: 256 KHz (line)
PCM Synchronization Format	Long/short synchronization
PCM Data Ordering	MSB first
Zero Padding	Yes
Sign Extension	Yes

3.9.2. Timing

The sample rate of the PCM interface is 8 KHz and the clock source is 256 KHz, so every frame contains 32 bits data, since M35 supports 16 bits line code PCM format, the left 16 bits are invalid. The following diagram shows the timing of different combinations. The synchronization length in long synchronization format can be programmed by firmware from one bit to eight bits. In the Sign extension mode, the high three bits of 16 bits are sign extension, and in the Zero padding mode, the low three bits of 16 bits are zero padding.

Under zero padding mode, you can configure the PCM input and output volume by executing “AT+QPCMVOL” command. For more details, please refer to **Chapter 3.9.4**.

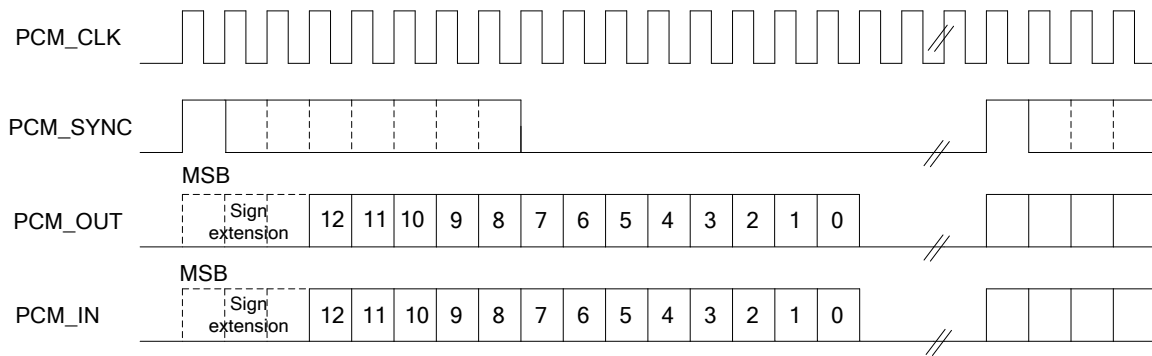

Figure 28: Long Synchronization & Sign Extension Diagram

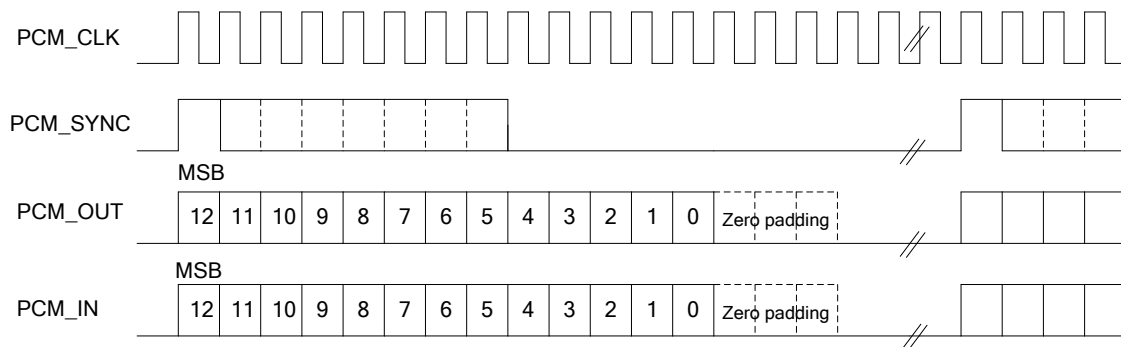

Figure 29: Long Synchronization & Zero Padding Diagram

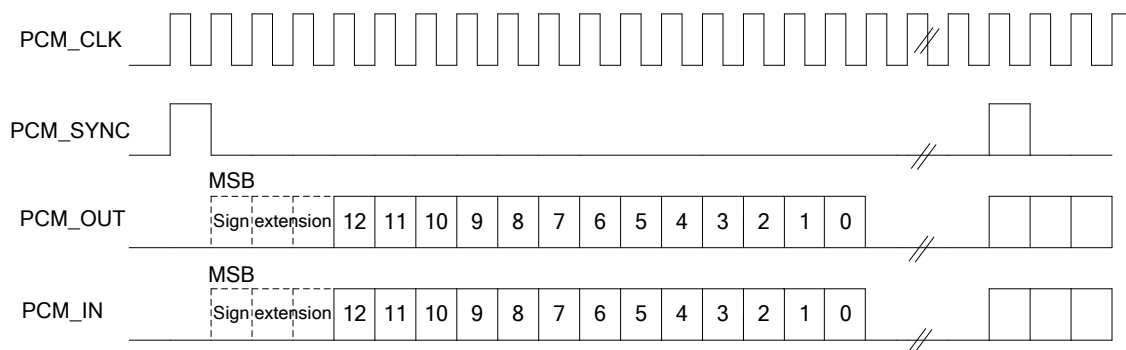

Figure 30: Short Synchronization & Sign Extension Diagram

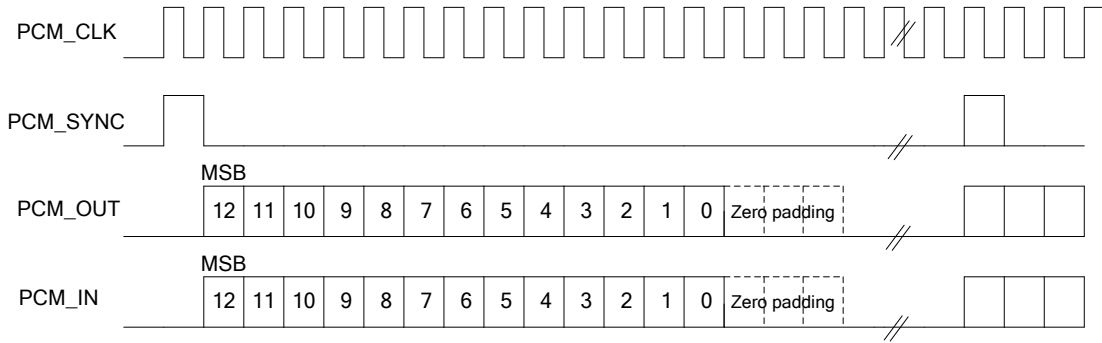

Figure 31: Short Synchronization & Zero Padding Diagram

3.9.3. Reference Design

M35 can only work as a master, providing synchronization and clock source. The reference design is shown as below.

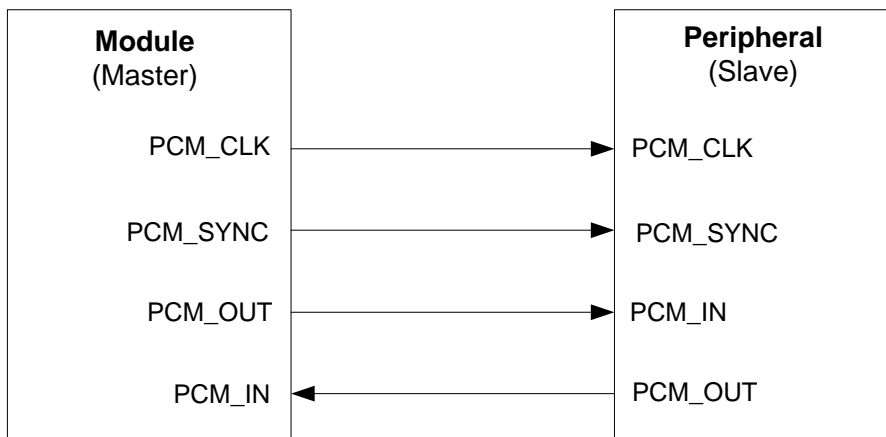

Figure 32: Reference Design for PCM

3.9.4. AT Command

There are two AT commands about the configuration of PCM, listed as below.

“AT+QPCMON” can configure operating mode of PCM.

AT+QPCMON=mode, Sync_Type, Sync_Length, SignExtension, MSBFirst.

Table 15: QPCMON Command Description

Parameter	Scope	Description
Mode	0~2	0: Close PCM 1: Open PCM 2: Open PCM when audio talk is set up
Sync_Type	0~1	0: Short synchronization 1: Long synchronization
Sync_Length	1~8	Programmed from one bit to eight bit
SignExtension	0~1	0: Zero padding 1: Sign extension
MSBFirst	0~1	0: MSB first 1: Not support

“AT+QPCMVOL” can configure the volume of input and output.

AT+QPCMVOL=vol_pcm_in, vol_pcm_out

Table 16: QPCMVOL Command Description

Parameter	Scope	Description
vol_pcm_in	0~32767	Set the input volume
vol_pcm_out	0~32767	Set the output volume The voice may be distorted when this value exceeds 16384.

3.10. SIM Card Interfaces

The module contains two smart interfaces to allow module access to the two SIM cards. These two SIM interfaces share the same ground and only SIM1 interface has card inserted detection. Only one SIM card can work at a time. For more details, please refer to the **document [6]**.

3.10.1. SIM Card Application

The SIM interfaces supports the functionality of the GSM Phase 1 specification and also supports the functionality of the new GSM Phase 2+ specification for FAST 64 kbps SIM card, which is intended for use with a SIM application Tool-kit.

The SIM interfaces are powered by an internal regulator in the module. Both 1.8V and 3.0V SIM Cards are supported.

Table 17: Pin Definition of the SIM Interfaces

Pin NO.	Name	Description	¹⁾ Alternate Function
27	SIM1_VDD	Supply power for SIM1 card. Automatic detection of SIM1 card voltage. 3.0V±5% and 1.8V±5%. Maximum supply current is around 10mA.	
30	SIM1_CLK	SIM1 card clock.	
29	SIM1_DATA	SIM1 card data I/O.	
28	SIM1_RST	SIM1 card reset.	
20	SIM1_PRESENCE	SIM1 card detection.	DTR
31	SIM_GND	SIM card ground.	
18	SIM2_VDD	Supply power for SIM2 card. Automatic detection of SIM2 card voltage. 3.0V±5% and 1.8V±5%. Maximum supply current is around 10mA.	
17	SIM2_CLK	SIM2 card clock.	
16	SIM2_DATA	SIM2 card data I/O.	
25	SIM2_RST	SIM2 card reset.	DCD

NOTE

¹⁾ If several interfaces share the same I/O pin, to avoid conflict between these alternate functions, only one peripheral should be enabled at a time.

The following figure is the reference design for SIM1 interface.

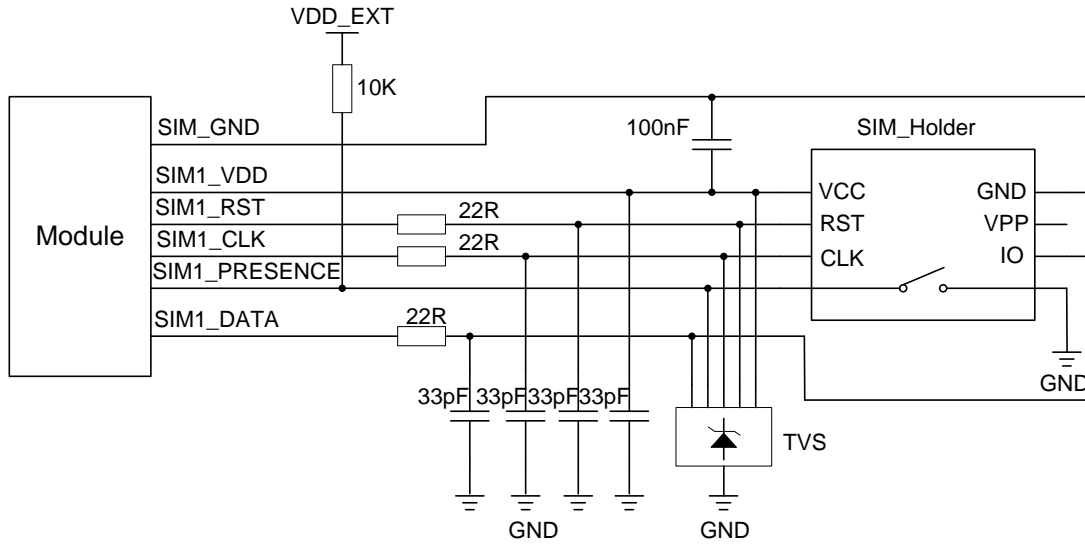

Figure 33: Reference Circuit for SIM1 Interface with 8-pin SIM Card Holder

If SIM1 card detection function is not used, keep SIM1_PRESENCE pin open. The reference circuit for a 6-pin SIM card socket is illustrated as the following figure.

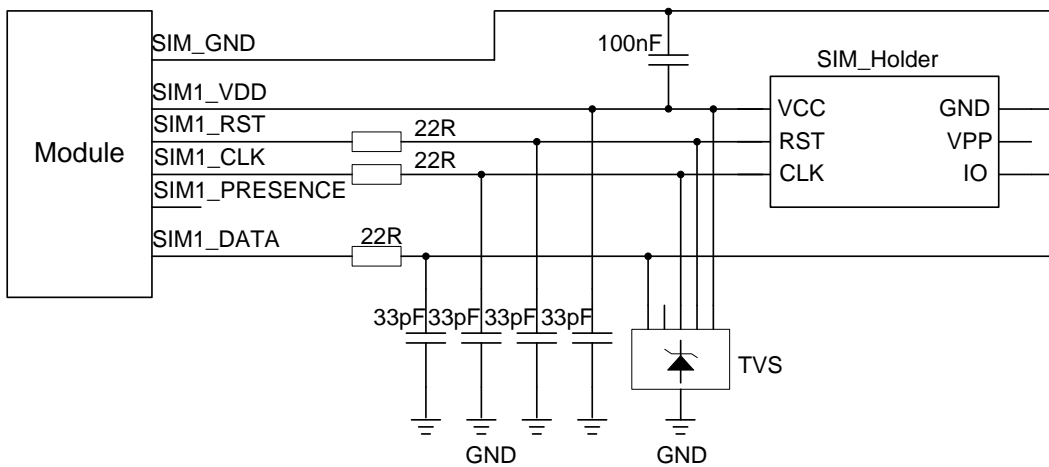

Figure 34: Reference Circuit for SIM1 Interface with the 6-pin SIM Card Holder

The following figure is the reference design for SIM2 interface with the 6-pin SIM card holder.

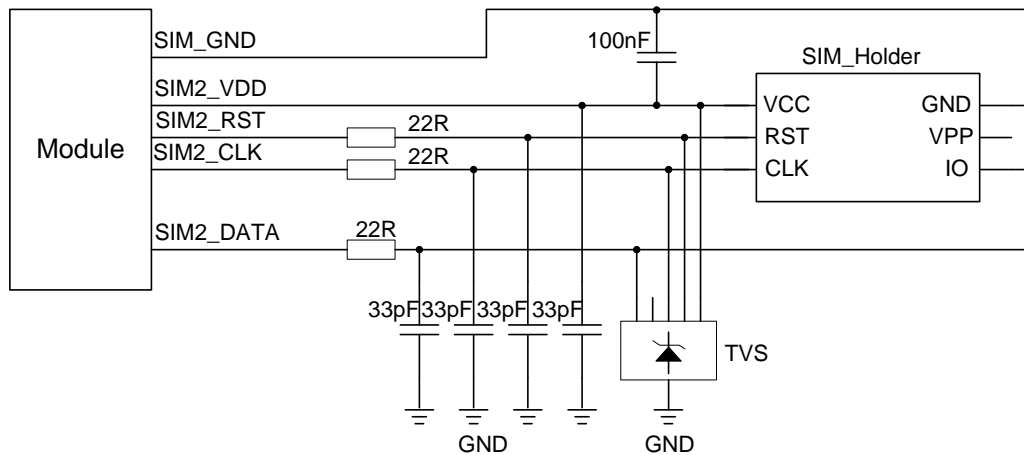

Figure 35: Reference Circuit for SIM2 Interface with the 6-pin SIM Card Holder

For more information of SIM card holder, you can visit <http://www.amphenol.com> and <http://www.molex.com>.

In order to enhance the reliability and availability of the SIM card in application. Please follow the below criteria in the SIM circuit design.

- Keep layout of SIM card as close as possible to the module. Assure the possibility of the length of the trace is less than 200mm.
- Keep SIM card signal away from RF and VBAT alignment.
- Assure the ground between module and SIM cassette short and wide. Keep the width of ground no less than 0.5mm to maintain the same electric potential. The decouple capacitor of SIM_VDD is less than 1uF and must be near to SIM cassette.
- To avoid cross talk between SIM_DATA and SIM_CLK. Keep them away with each other and shield them with surrounded ground
- In order to offer good ESD protection, it is recommended to add a TVS diode array. For more information of TVS diode, you can visit <http://www.onsemi.com/>. The most important rule is to place your ESD protection device close to the SIM card socket and make sure the net being protected will go through the ESD protection device first and then lead to module. The 22Ω resistors should be connected in series between the module and the SIM card so as to suppress the EMI spurious transmission and enhance the ESD protection. Please to be noted that the SIM peripheral circuit should be close to the SIM card socket.
- Place the RF bypass capacitors (33pF) close to the SIM card on all signals line for improving EMI.

3.11. Behaviors of The RI

When using PCM interface, RI pin can be used as PCM_CLK.

Table 18: Behaviors of the RI

State	RI Response
Standby	HIGH
Voice Calling	Change to LOW, then: <ol style="list-style-type: none"> 1. Change to HIGH when call is established. 2. Use ATH to hang up the call, RI changes to HIGH. 3. Calling part hangs up, RI changes to HIGH first, and changes to LOW for 120ms indicating "NO CARRIER" as an URC, then changes to HIGH again. 4. Change to HIGH when SMS is received.
SMS	When a new SMS comes, the RI changes to LOW and holds low level for about 120ms, then changes to HIGH.
URC	Certain URCs can trigger 120ms low level on RI. For more details, please refer to the document [1] .

NOTE

If URC of SMS is disabled, the RI will not change.

If the module is used as a caller, the RI would maintain high except the URC or SMS is received. On the other hand, when it is used as a receiver, the timing of the RI is shown as below.

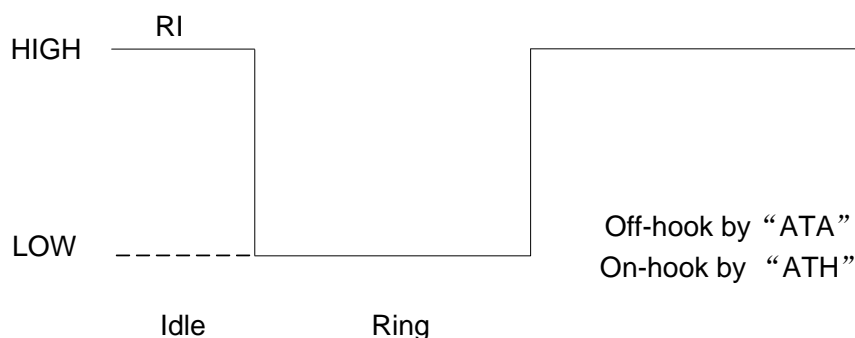

Figure 36: RI Behavior of Voice Calling as a Receiver

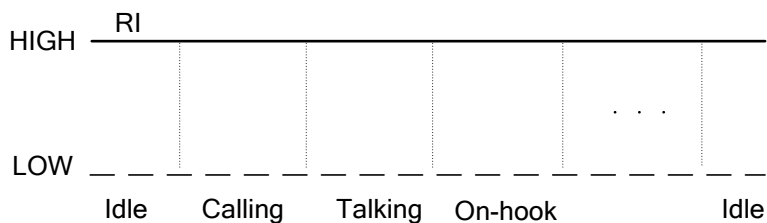

Figure 37: RI Behavior as a Caller

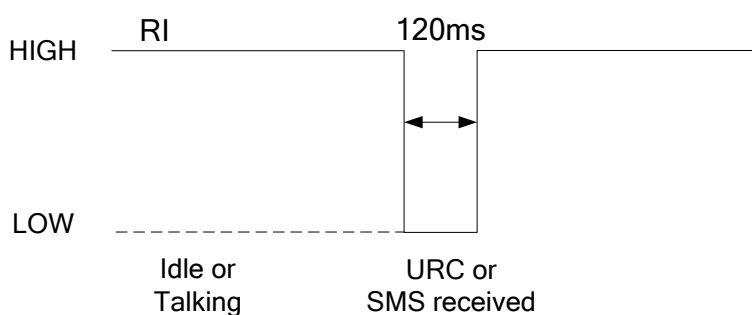

Figure 38: RI Behavior of URC or SMS Received

3.12. Network Status Indication

The NETLIGHT signal can be used to drive a network status indicator LED. The working state of this pin is listed in the following table.

Table 19: Working State of the NETLIGHT

State	Module Function
Off	The module is not running.
64ms On/800ms Off	The module is not synchronized with network.
64ms On/2000ms Off	The module is synchronized with network.
64ms On/600ms Off	The GPRS data transmission after dialing the PPP connection.

A reference circuit is shown as below.

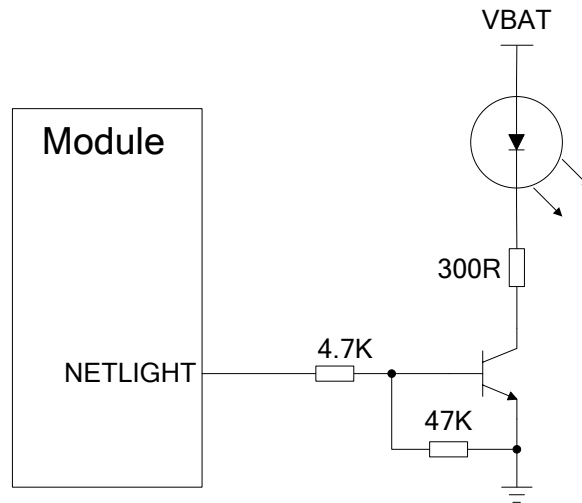

Figure 39: Reference Design for NETLIGHT

3.13. Operating Status Indication

The STATUS pin will output a high level after the module being turned on. but it is not recommended connecting this pin to a MCU's GPIO to judge whether the module is turn-on or not. The following LED indicator circuit for STATUS pin can be used to indicate the state after the module has been turned on.

Table 20: Pin Definition of the STATUS

Name	Pin	Description	¹⁾ Alternate Function
STATUS	12	Indicate module operating status	PCM_SYNC

NOTE

¹⁾When using PCM interface, STATUS pin can be used as PCM_SYNC.

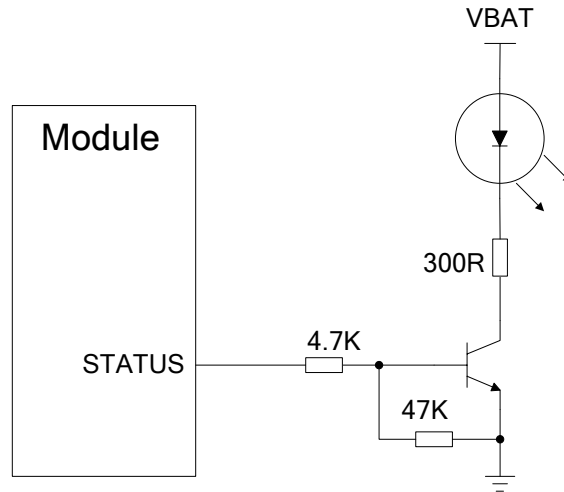

Figure 40: Reference Design for STATUS

4 Antenna Interface

The Pin 39 is the RF antenna pad. The RF interface has an impedance of 50Ω.

Table 21: Pin Definition of the RF_ANT

Name	Pin	Description
GND	37	Ground
GND	38	Ground
RF_ANT	39	RF antenna pad
GND	40	Ground

4.1. RF Reference Design

The reference design for RF is shown as below.

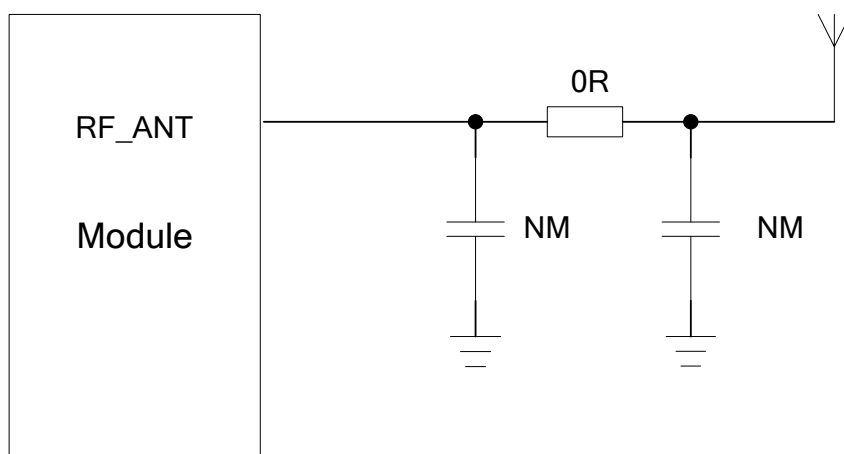

Figure 41: Reference Design for RF

M35 provides an RF antenna pad for antenna connection. The RF trace in host PCB connected to the module RF antenna pad should be coplanar waveguide line or microstrip line, whose characteristic impedance should be close to 50Ω. M35 comes with grounding pads which are next to the antenna pad in

order to give a better grounding. Besides, a π -type match circuit is suggested to be used to adjust the RF performance.

4.2. RF Output Power

Table 22: The Module Conducted RF Output Power

Frequency	Max.	Min.
GSM850	33dBm \pm 2dB	5dBm \pm 5dB
EGSM900	33dBm \pm 2dB	5dBm \pm 5dB
DCS1800	30dBm \pm 2dB	0dBm \pm 5dB
PCS1900	30dBm \pm 2dB	0dBm \pm 5dB

NOTE

In GPRS 4 slots TX mode, the max output power is reduced by 2.5dB. This design conforms to the GSM specification as described in section **13.16** of **3GPP TS 51.010-1**.

4.3. RF Receiving Sensitivity

Table 23: The Module Conducted RF Receiving Sensitivity

Frequency	Receive Sensitivity
GSM850	< -109dBm
EGSM900	< -109dBm
DCS1800	< -109dBm
PCS1900	< -109dBm

4.4. Operating Frequencies

Table 24: The Module Operating Frequencies

Frequency	Receive	Transmit	ARFCH
GSM850	869~894MHz	824~849MHz	128~251
EGSM900	925~960MHz	880~915MHz	0~124, 975~1023
DCS1800	1805~1880MHz	1710~1785MHz	512~885
PCS1900	1930~1990MHz	1850~1910MHz	512~810

4.5. Antenna Requirement

The following table shows the requirement on GSM antenna.

Table 25: Antenna Cable Requirements

Type	Requirements
GSM850/EGSM900	Cable insertion loss <1dB
DCS1800/PCS1900	Cable insertion loss <1.5dB

Table 26: Antenna Requirements

Type	Requirements
Frequency Range	GSM850/EGSM900/DCS1800/PCS1900MHz.
VSWR	≤ 2
Gain (dBi)	1
Max Input Power (W)	50
Input Impedance (Ω)	50
Polarization Type	Vertical

4.6. RF Cable Soldering

Soldering the RF cable to RF pad of module correctly will reduce the loss on the path of RF, please refer to the following example of RF soldering.

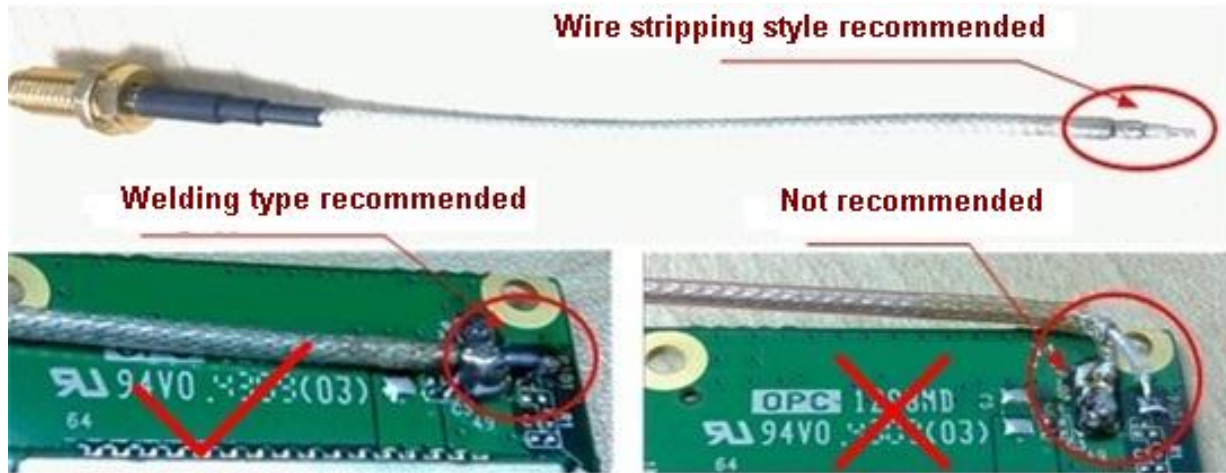

Figure 42: RF Soldering Sample

5 Electrical, Reliability and Radio Characteristics

5.1. Absolute Maximum Ratings

Absolute maximum ratings for power supply and voltage on digital and analog pins of module are listed in the following table:

Table 27: Absolute Maximum Ratings

Parameter	Min.	Max.	Unit
VBAT	-0.3	+4.73	V
Peak Current of Power Supply	0	2	A
RMS Current of Power Supply (during one TDMA- frame)	0	0.7	A
Voltage at Digital Pins	-0.3	3.08	V
Voltage at Analog Pins	-0.3	3.08	V
Voltage at Digital/analog Pins in Power Down Mode	-0.25	0.25	V

5.2. Operating Temperature

The operating temperature is listed in the following table:

Table 28: Operating Temperature

Parameter	Min.	Typ.	Max.	Unit
Normal Temperature	-35	+25	+80	°C

Restricted Operation ¹⁾	-40 ~ -35	+80 ~ +85	°C
Storage Temperature	-45	+90	°C

NOTE

¹⁾ When the module works within this temperature range, the deviation from the GSM specification may occur. For example, the frequency error or the phase error will be increased.

5.3. Power Supply Ratings

Table 29: The Module Power Supply Ratings

Parameter	Description	Conditions	Min.	Typ.	Max.	Unit	
VBAT	Supply voltage	Voltage must stay within the min/max values, including voltage drop, ripple, and spikes.	3.3	4.0	4.6	V	
	Voltage drop during transmitting burst	Maximum power control level on GSM850 and EGSM900.			400	mV	
I _{VBAT}	Average supply current	Power down mode		150		uA	
		SLEEP mode @DRX=5		1.3		mA	
		Minimum functionality mode					
		AT+CFUN=0					
		IDLE mode			13		mA
		SLEEP mode			0.98		mA
		AT+CFUN=4					
		IDLE mode			13		mA
		SLEEP mode			1.0		mA
		TALK mode					
GSM850/EGSM900 ¹⁾			223/219		mA		
DCS1800/PCS1900 ²⁾			153/151		mA		
DATA mode, GPRS (3Rx,2Tx)							
GSM850/EGSM900 ¹⁾			363/393		mA		
DCS1800/PCS1900 ²⁾			268/257		mA		
DATA mode, GPRS(2 Rx,3Tx)							
GSM850/EGSM900 ¹⁾			506/546		mA		
DCS1800/PCS1900 ²⁾			366/349		mA		

	DATA mode, GPRS (4Rx,1Tx)			
	GSM850/EGSM900 ¹⁾	217/234		mA
	DCS1800/PCS1900 ²⁾	172/170		mA
	DATA mode, GPRS (1Rx,4Tx)			
	GSM850/EGSM900 ¹⁾	458/485		mA
	DCS1800/PCS1900 ²⁾	462/439		mA
Peak supply current (during transmission slot)	Maximum power control level on GSM850 and EGSM900.	1.6	2	A

NOTE

1. ¹⁾ Power control level PCL 5.
2. ²⁾ Power control level PCL 0.
3. Under the EGSM900 spectrum, the power of 1Rx and 4Tx has been reduced.

5.4. Current Consumption

The values of current consumption are shown as below.

Table 30: The Module Current Consumption

Condition	Current Consumption
Voice Call	
GSM850	@power level #5 <300mA, Typical 223mA
	@power level #12, Typical 83mA
	@power level #19, Typical 62mA
EGSM900	@power level #5 <300mA, Typical 219mA
	@power level #12, Typical 83mA
	@power level #19, Typical 63mA
DCS1800	@power level #0 <250mA, Typical 153mA
	@power level #7, Typical 73mA
	@power level #15, Typical 60mA
PCS1900	@power level #0 <250mA, Typical 151mA
	@power level #7, Typical 76mA
	@power level #15, Typical 61mA
GPRS Data	

DATA Mode, GPRS (3 Rx, 2Tx) CLASS 10

GSM850	@power level #5 <550mA, Typical 363mA @power level #12, Typical 131mA @power level #19, Typical 91mA
--------	--

EGSM900	@power level #5 <550mA, Typical 393mA @power level #12, Typical 132mA @power level #19, Typical 92mA
---------	--

DCS1800	@power level #0 <450mA, Typical 268mA @power level #7, Typical 112mA @power level #15, Typical 88mA
---------	---

PCS1900	@power level #0 <450mA, Typical 257mA @power level #7, Typical 119mA @power level #15, Typical 89mA
---------	---

DATA Mode, GPRS (4 Rx, 1Tx) CLASS 10

GSM850	@power level #5 <350mA, Typical 216mA @power level #12, Typical 103mA @power level #19, Typical 83mA
--------	--

EGSM900	@power level #5 <350mA, Typical 233mA @power level #12, Typical 104mA @power level #19, Typical 84mA
---------	--

DCS1800	@power level #0 <300mA, Typical 171mA @power level #7, Typical 96mA @power level #15, Typical 82mA
---------	--

PCS1900	@power level #0 <300mA, Typical 169mA @power level #7, Typical 98mA @power level #15, Typical 83mA
---------	--

NOTE

GPRS Class 10 is the default setting. The module can be configured from GPRS Class 1 to Class 10. Setting to lower GPRS class would make it easier to design the power supply for the module.

5.5. Electro-static Discharge

Although the GSM engine is generally protected against Electro-static Discharge (ESD), ESD protection precautions should still be emphasized. Proper ESD handling and packaging procedures must be applied throughout the processing, handling and operation of any applications using the module.

The measured ESD values of module are shown as the following table:

Table 31: The ESD Endurance (Temperature: 25°C, Humidity: 45%)

Tested Point	Contact Discharge	Air Discharge
VBAT,GND	±5KV	±10KV
RF_ANT	±5KV	±10KV
TXD, RXD	±2KV	±4KV
Others	±0.5KV	±1KV

6 Mechanical Dimensions

This chapter describes the mechanical dimensions of the module.

6.1. Mechanical Dimensions of Module

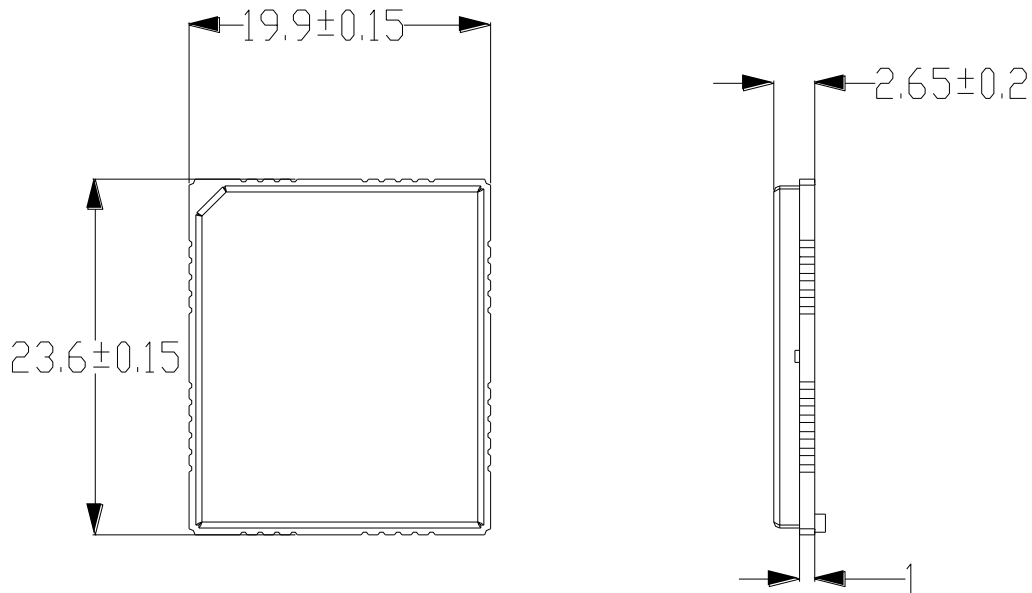

Figure 43: M35 Module Top and Side Dimensions (Unit: mm)

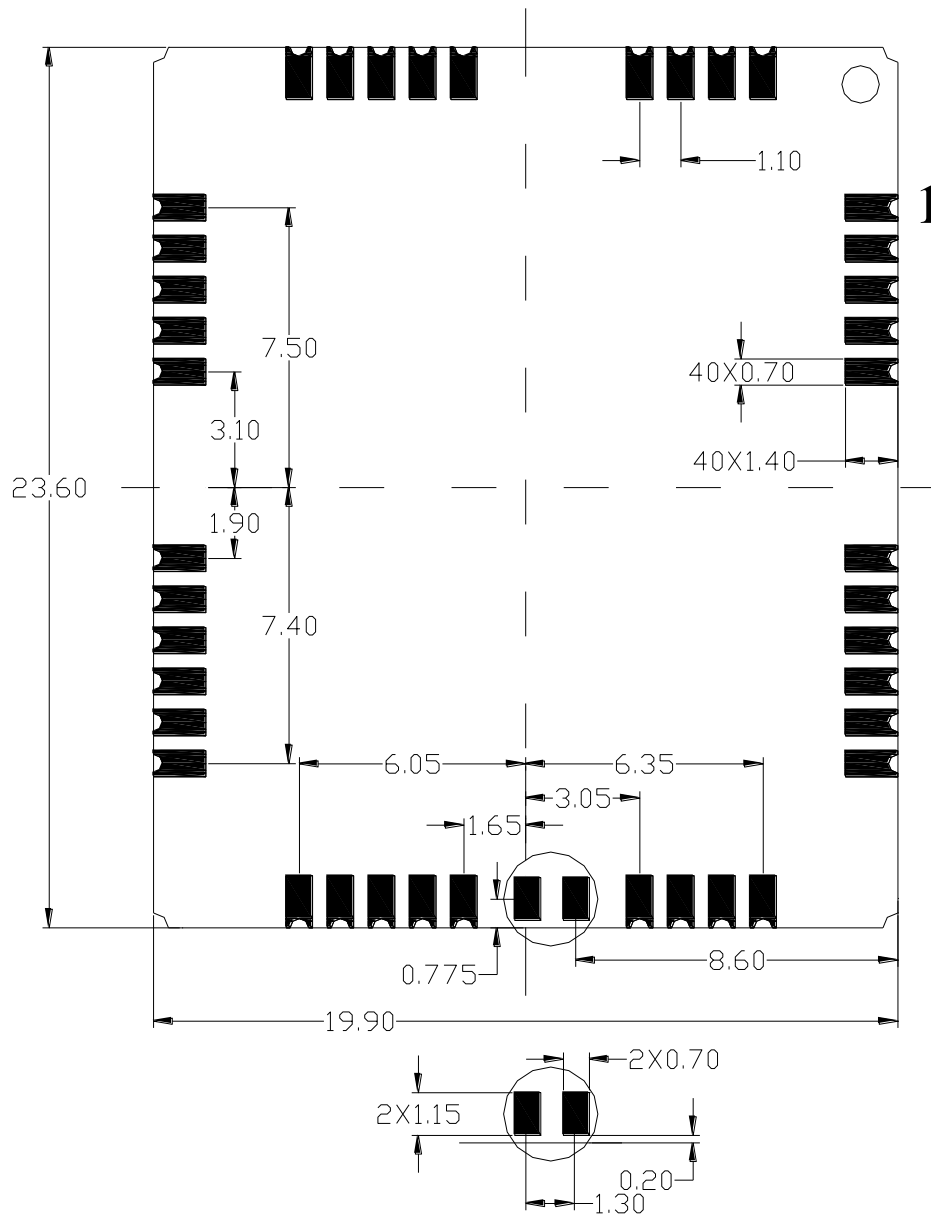

Figure 44: M35 Module Bottom Dimensions (Unit: mm)

6.2. Recommended Footprint

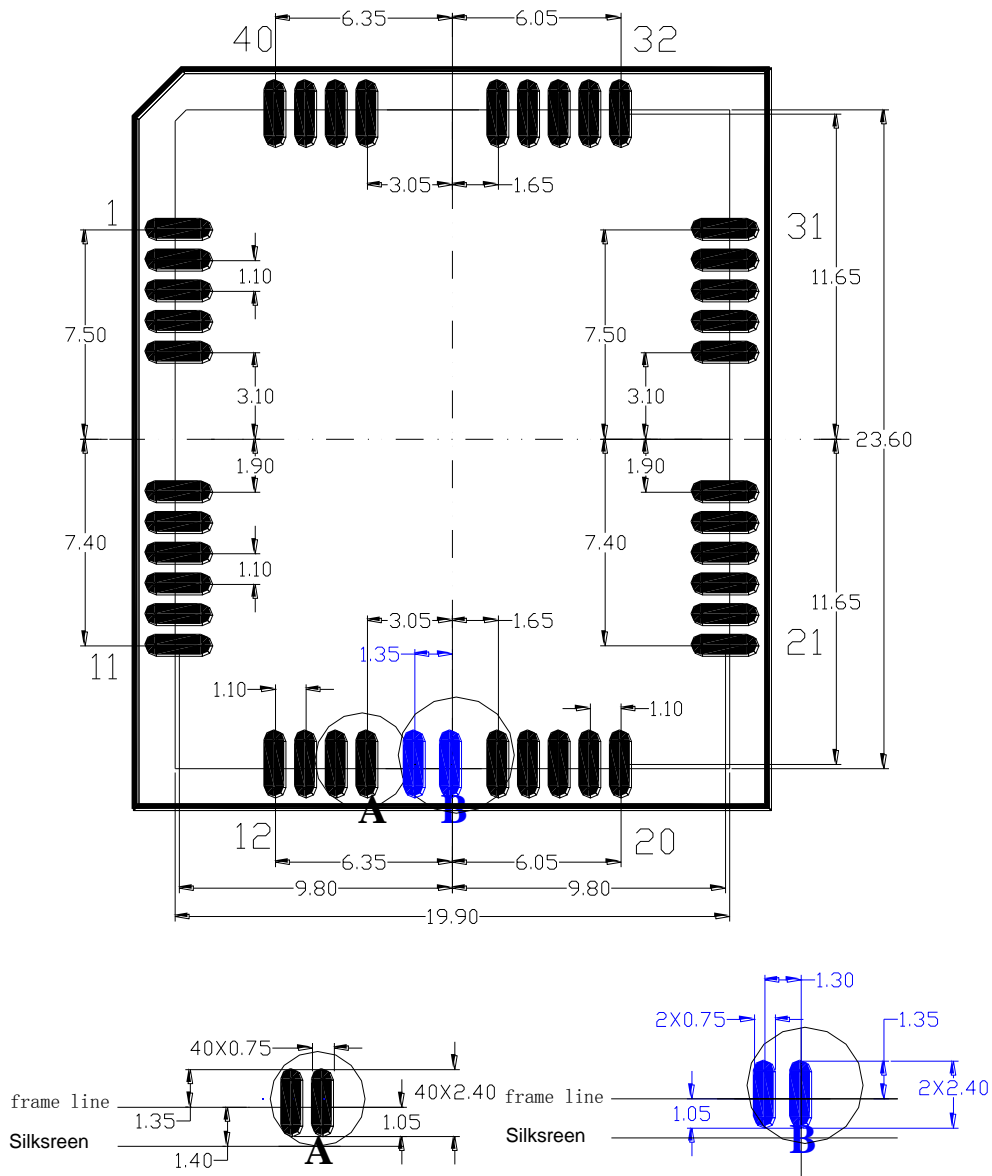

Figure 45: Recommended Footprint (Unit: mm)

NOTE

The module should keep about 3mm away from other components in the host PCB.

6.3. Top View of the Module

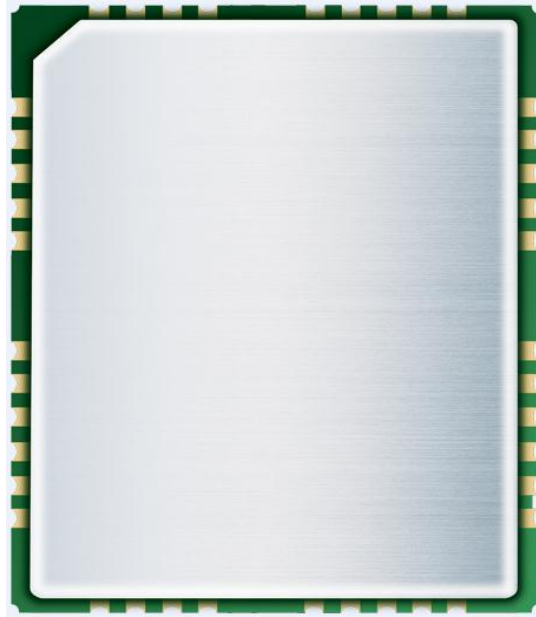

Figure 46: Top View of the Module

6.4. Bottom View of the Module

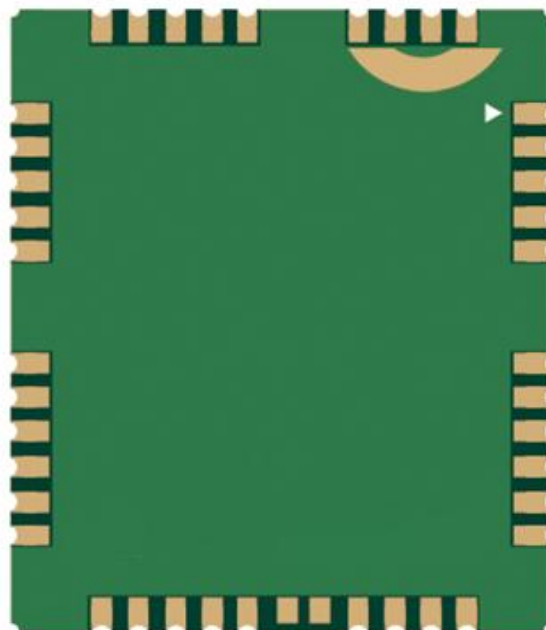

Figure 47: Bottom View of the Module

7 Storage and Manufacturing

7.1. Storage

M35 module is distributed in a vacuum-sealed bag. The restriction for storage is shown as below.

Shelf life in the vacuum-sealed bag: 12 months at environments of $<40^{\circ}\text{C}$ temperature and $<90\% \text{RH}$.

After the vacuum-sealed bag is opened, devices that need to be mounted directly must be:

- Mounted within 72 hours at the factory environment of $\leq 30^{\circ}\text{C}$ temperature and $<60\% \text{RH}$.
- Stored at $<10\% \text{RH}$.

Devices require baking before mounting, if any circumstance below occurs.

- When the ambient temperature is $23^{\circ}\text{C} \pm 5^{\circ}\text{C}$, humidity indication card shows the humidity is $>10\%$ before opening the vacuum-sealed bag.
- If ambient temperature is $<30^{\circ}\text{C}$ and the humidity is $<60\%$, the devices have not been mounted during 72hours.
- Stored at $>10\% \text{RH}$.

If baking is required, devices should be baked for 48 hours at $125^{\circ}\text{C} \pm 5^{\circ}\text{C}$.

NOTE

As plastic container cannot be subjected to high temperature, devices must be removed prior to high temperature (125°C) bake. If shorter bake times are desired, refer to the IPC/JEDECJ-STD-033 for bake procedure.

7.2. Soldering

The squeegee should push the paste on the surface of the stencil that makes the paste fill the stencil openings and penetrate to the PCB. The force on the squeegee should be adjusted so as to produce a clean stencil surface on a single pass. To ensure the module soldering quality, the thickness of stencil at the hole of the module pads should be 0.2 mm for M35. For more details, please refer to **document [5]**.

It is suggested that peak reflow temperature is from 235°C to 245°C (for SnAg3.0Cu0.5 alloy). Absolute max reflow temperature is 260°C. To avoid damage to the module when it was repeatedly heated, it is suggested that the module should be mounted after the first panel has been reflowed. The following picture is the actual diagram which we have operated.

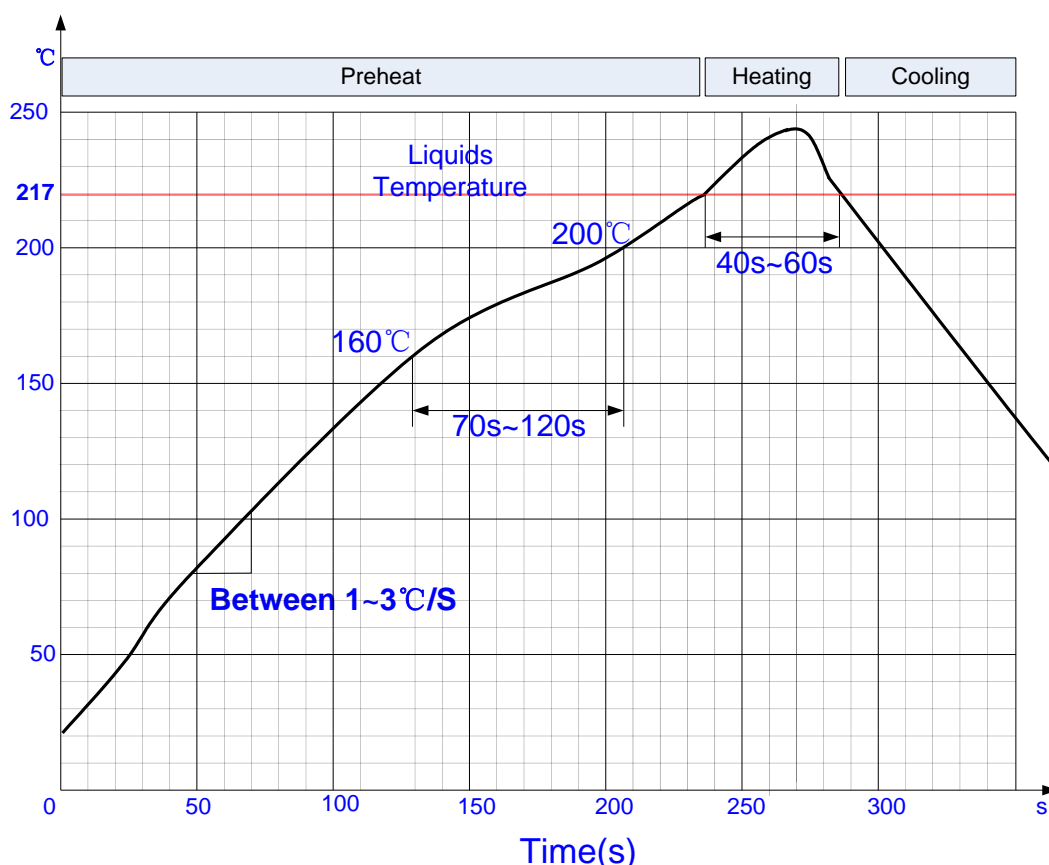

Figure 48: Ramp-Soak-Spike Reflow Profile

7.3. Packaging

The modules are stored inside a vacuum-sealed bag which is ESD protected. It should not be opened until the devices are ready to be soldered onto the application.

7.3.1. Tape and Reel Packaging

The reel is 330mm in diameter and each reel contains 250 modules.

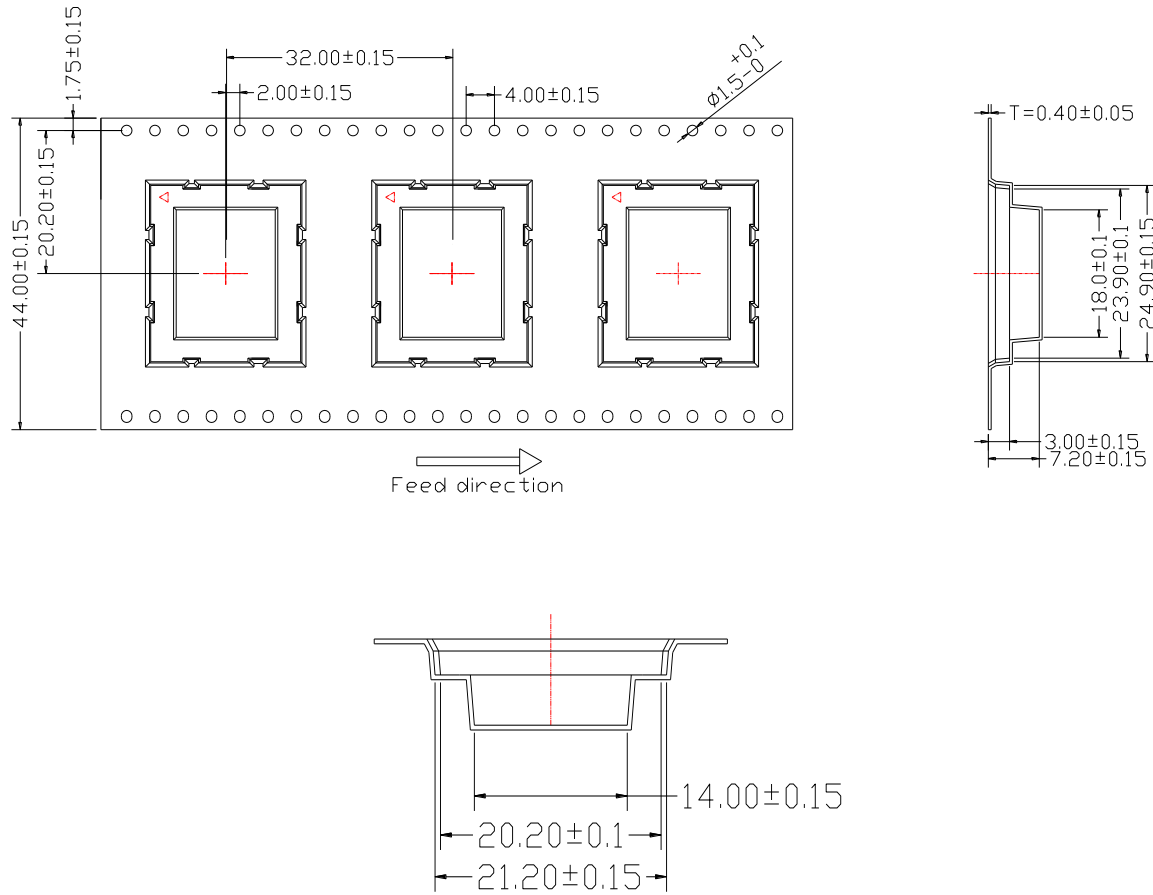

Figure 49: Tape and Reel Specification

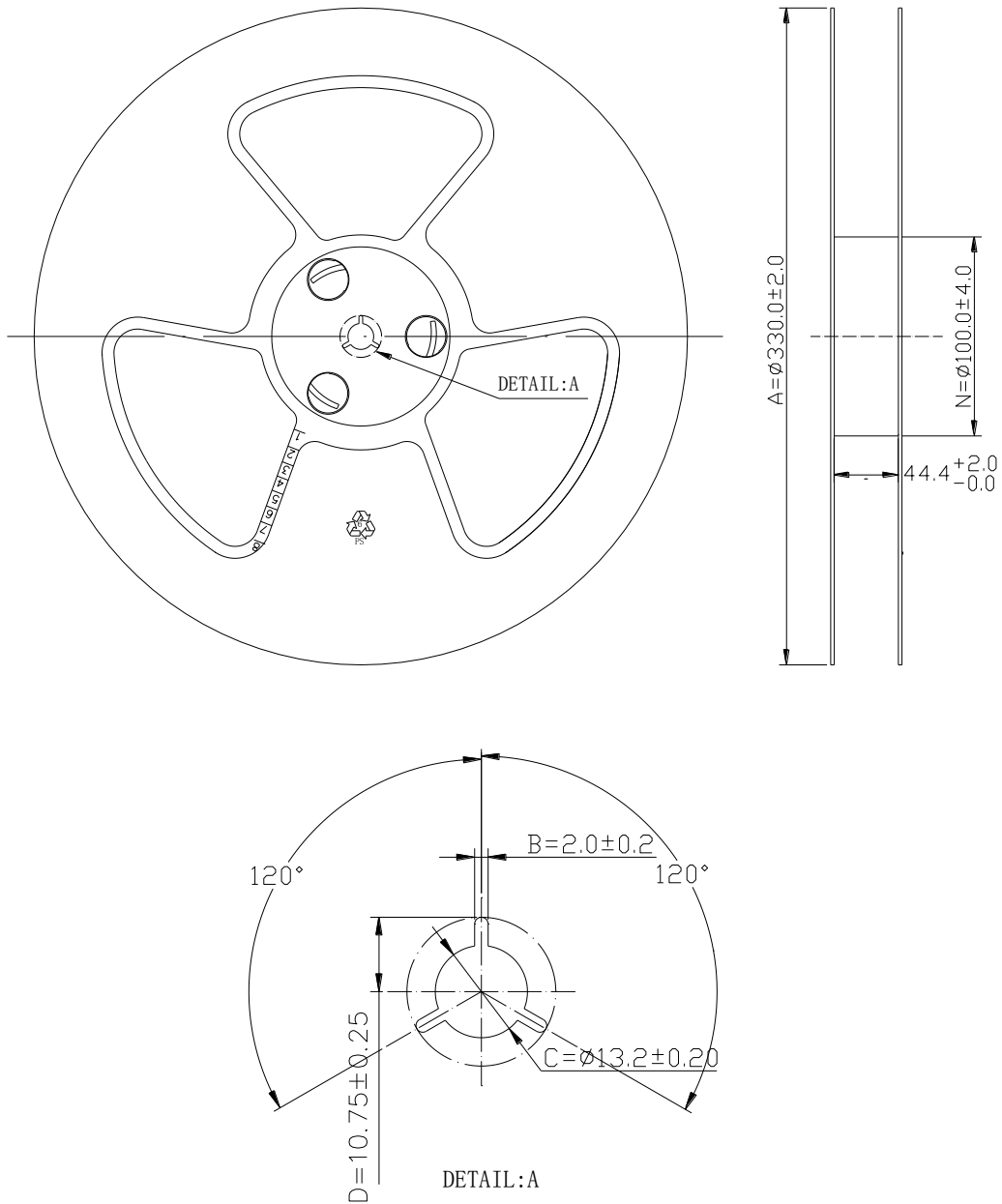

Figure 50: Dimensions of Reel

Table 32: Reel Packing

Model Name	MOQ for MP	Minimum Package: 250pcs	Minimum Package×4=1000pcs
M35	250pcs	Size: 370 × 350 × 56mm ³ N.W: 0.63kg G.W: 1.47kg	Size: 380 × 250 × 365mm ³ N.W: 2.5kg G.W: 6.4kg

8 Appendix A Reference

Table 33: Related Documents

SN	Document Name	Remark
[1]	Quectel_M35_AT_Commands_Manual	AT commands manual
[2]	ITU-T Draft new recommendation V.25ter	Serial asynchronous automatic dialing and control
[3]	GSM_UART_Application_Note	UART port application note
[4]	GSM_EVB_User_Guide	GSM EVB user guide
[5]	Module_Secondary_SMT_User_Guide	Module secondary SMT user guide
[6]	M35_Dual_SIM_Application_Notes_V3.0	M35 Dual SIM Application Notes
[7]	GSM_Multi_UART_Application_Note	M35 Multi UART Application Notes
[8]	Quectel_GSM_Module_Digital_IO_Application_Note	GSM module digital IO application note
[9]	GSM 07.07	Digital cellular telecommunications (Phase 2+); AT command set for GSM Mobile Equipment (ME)
[10]	GSM 07.10	Support GSM 07.10 multiplexing protocol
[11]	GSM 07.05	Digital cellular telecommunications (Phase 2+); Use of Data Terminal Equipment – Data Circuit terminating Equipment (DTE – DCE) interface for Short Message Service (SMS) and Cell Broadcast Service (CBS)
[12]	GSM 11.14	Digital cellular telecommunications (Phase 2+); Specification of the SIM Application Toolkit for the Subscriber Identity module – Mobile Equipment (SIM – ME) interface
[13]	GSM 11.11	Digital cellular telecommunications (Phase 2+); Specification of the Subscriber Identity module – Mobile Equipment (SIM – ME) interface

[14]	GSM 03.38	Digital cellular telecommunications (Phase 2+); Alphabets and language-specific information
[15]	GSM 11.10	Digital cellular telecommunications (Phase 2); Mobile Station (MS) conformance specification; Part 1: Conformance specification

Table 34: Terms and Abbreviations

Abbreviation	Description
ADC	Analog-to-Digital Converter
AMR	Adaptive Multi-Rate
ARP	Antenna Reference Point
ASIC	Application Specific Integrated Circuit
BER	Bit Error Rate
BOM	Bill of Material
BTS	Base Transceiver Station
CHAP	Challenge Handshake Authentication Protocol
CS	Coding Scheme
CSD	Circuit Switched Data
CTS	Clear To Send
DAC	Digital-to-Analog Converter
DRX	Discontinuous Reception
DSP	Digital Signal Processor
DCE	Data Communications Equipment (typically module)
DTE	Data Terminal Equipment (typically computer, external controller)
DTR	Data Terminal Ready
DTX	Discontinuous Transmission

EFR	Enhanced Full Rate
EGSM	Enhanced GSM
EMC	Electromagnetic Compatibility
ESD	Electrostatic Discharge
ETS	European Telecommunication Standard
FCC	Federal Communications Commission (U.S.)
FDMA	Frequency Division Multiple Access
FR	Full Rate
GMSK	Gaussian Minimum Shift Keying
GPRS	General Packet Radio Service
GSM	Global System for Mobile Communications
G.W	Gross Weight
HR	Half Rate
I/O	Input/Output
IC	Integrated Circuit
IMEI	International Mobile Equipment Identity
Imax	Maximum Load Current
Inorm	Normal Current
kbps	Kilo Bits Per Second
LED	Light Emitting Diode
Li-Ion	Lithium-Ion
MO	Mobile Originated
MOQ	Minimum Order Quantity
MP	Manufacture Product
MS	Mobile Station (GSM engine)

MT	Mobile Terminated
N.W	Net Weight
PAP	Password Authentication Protocol
PBCCH	Packet Switched Broadcast Control Channel
PCB	Printed Circuit Board
PDU	Protocol Data Unit
PPP	Point-to-Point Protocol
RF	Radio Frequency
RMS	Root Mean Square (value)
RTC	Real Time Clock
RX	Receive Direction
SIM	Subscriber Identification Module
SMS	Short Message Service
TDMA	Time Division Multiple Access
TE	Terminal Equipment
TX	Transmitting Direction
UART	Universal Asynchronous Receiver & Transmitter
URC	Unsolicited Result Code
USSD	Unstructured Supplementary Service Data
VSWR	Voltage Standing Wave Ratio
Vmax	Maximum Voltage Value
Vnorm	Normal Voltage Value
Vmin	Minimum Voltage Value
VIHmax	Maximum Input High Level Voltage Value
VIHmin	Minimum Input High Level Voltage Value

VILmax	Maximum Input Low Level Voltage Value
VILmin	Minimum Input Low Level Voltage Value
VImax	Absolute Maximum Input Voltage Value
VImin	Absolute Minimum Input Voltage Value
VOHmax	Maximum Output High Level Voltage Value
VOHmin	Minimum Output High Level Voltage Value
VOLmax	Maximum Output Low Level Voltage Value
VOLmin	Minimum Output Low Level Voltage Value

Phonebook Abbreviations

LD	SIM Last Dialing phonebook (list of numbers most recently dialed)
MC	Mobile Equipment list of unanswered MT Calls (missed calls)
ON	SIM (or ME) Own Numbers (MSISDNs) list
RC	Mobile Equipment list of Received Calls
SM	SIM phonebook

9 Appendix B GPRS Coding Scheme

Four coding schemes are used in GPRS protocol. The differences between them are shown in the following table.

Table 35: Description of Different Coding Schemes

Scheme	Code Rate	USF	Pre-coded USF	Radio Block excl.USF and BCS	BCS	Tail	Coded Bits	Punctured Bits	Data Rate Kb/s
CS-1	1/2	3	3	181	40	4	456	0	9.05
CS-2	2/3	3	6	268	16	4	588	132	13.4
CS-3	3/4	3	6	312	16	4	676	220	15.6
CS-4	1	3	12	428	16	-	456	-	21.4

Radio block structure of CS-1, CS-2 and CS-3 is shown as the figure below.

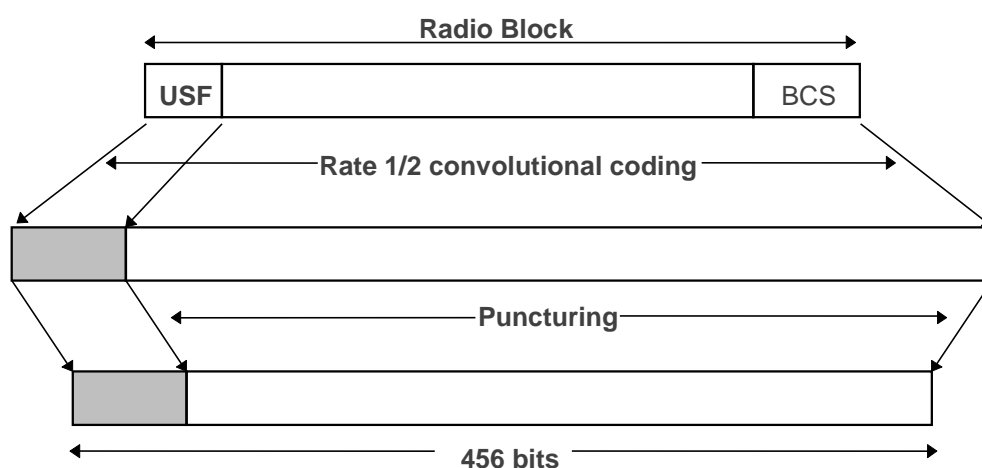

Figure 51: Radio Block Structure of CS-1, CS-2 and CS-3

Radio block structure of CS-4 is shown as the following figure.

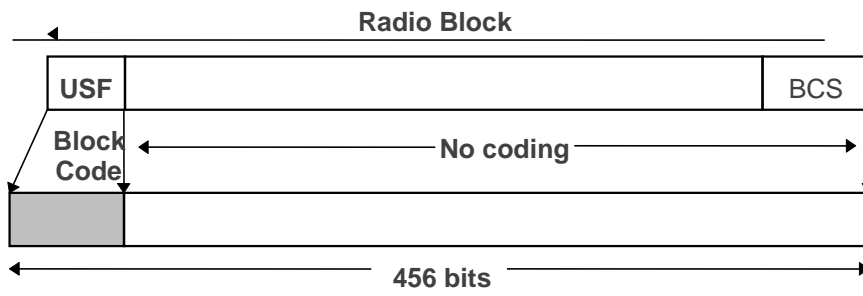

Figure 52: Radio Block Structure of CS-4

10 Appendix C GPRS Multi-slot Class

Twenty-nine classes of GPRS multi-slot modes are defined for MS in GPRS specification. Multi-slot classes are product dependant, and determine the maximum achievable data rates in both the uplink and downlink directions. Written as 3+1 or 2+2, the first number indicates the amount of downlink timeslots, while the second number indicates the amount of uplink timeslots. The active slots determine the total number of slots the GPRS device can use simultaneously for both uplink and downlink communications. The description of different multi-slot classes is shown in the following table.

Table 36: GPRS Multi-slot Classes

Multislot Class	Downlink Slots	Uplink Slots	Active Slots
1	1	1	2
2	2	1	3
3	2	2	3
4	3	1	4
5	2	2	4
6	3	2	4
8	4	1	5
9	3	2	5
10	4	2	5