

# EC21 Hardware Design

**LTE Module Series**

Rev. EC21\_Hardware\_Design\_V1.4

Date: 2017-03-01



**Our aim is to provide customers with timely and comprehensive service. For any assistance, please contact our company headquarters:**

**Quectel Wireless Solutions Co., Ltd.**

Office 501, Building 13, No.99, Tianzhou Road, Shanghai, China, 200233

Tel: +86 21 5108 6236

Email:[info@quectel.com](mailto:info@quectel.com)

**Or our local office. For more information, please visit:**

<http://www.quectel.com/support/salesupport.aspx>

**For technical support, or to report documentation errors, please visit:**

<http://www.quectel.com/support/techsupport.aspx>

Or email to: [Support@quectel.com](mailto:Support@quectel.com)

**GENERAL NOTES**

QUECTEL OFFERS THE INFORMATION AS A SERVICE TO ITS CUSTOMERS. THE INFORMATION PROVIDED IS BASED UPON CUSTOMERS' REQUIREMENTS. QUECTEL MAKES EVERY EFFORT TO ENSURE THE QUALITY OF THE INFORMATION IT MAKES AVAILABLE. QUECTEL DOES NOT MAKE ANY WARRANTY AS TO THE INFORMATION CONTAINED HEREIN, AND DOES NOT ACCEPT ANY LIABILITY FOR ANY INJURY, LOSS OR DAMAGE OF ANY KIND INCURRED BY USE OF OR RELIANCE UPON THE INFORMATION. THE INFORMATION SUPPLIED HEREIN IS SUBJECT TO CHANGE WITHOUT PRIOR NOTICE.

**COPYRIGHT**

THE INFORMATION CONTAINED HERE IS PROPRIETARY TECHNICAL INFORMATION OF QUECTEL CO., LTD. TRANSMITTING, REPRODUCTION, DISSEMINATION AND EDITING OF THIS DOCUMENT AS WELL AS UTILIZATION OF THE CONTENT ARE FORBIDDEN WITHOUT PERMISSION. OFFENDERS WILL BE HELD LIABLE FOR PAYMENT OF DAMAGES. ALL RIGHTS ARE RESERVED IN THE EVENT OF A PATENT GRANT OR REGISTRATION OF A UTILITY MODEL OR DESIGN.

***Copyright © Quectel Wireless Solutions Co., Ltd. 2017. All rights reserved.***

# About the Document

## History

Revision	Date	Author	Description
1.0	2016-04-15	Yeoman CHEN	Initial
1.1	2016-09-22	Yeoman CHEN/ Frank WANG/ Lyndon LIU	<ol style="list-style-type: none"> <li>Updated frequency bands in Table 1.</li> <li>Updated transmitting power, supported maximum baud rate of main UART, supported internet protocols, supported USB drivers of USB interface, and temperature range in Table 2.</li> <li>Updated timing of turning on module in Figure 12.</li> <li>Updated timing of turning off module in Figure 13.</li> <li>Updated timing of resetting module in Figure 16.</li> <li>Updated main UART supports baud rate in Chapter 3.11.</li> <li>Added notes for ADC interface in Chapter 3.13.</li> <li>Updated GNSS Performance in Table 21.</li> <li>Updated operating frequencies of module in Table 23.</li> <li>Added current consumption in Chapter 6.4.</li> <li>Updated RF output power in Chapter 6.5.</li> <li>Added RF receiving sensitivity in Chapter 6.6.</li> </ol>
1.2	2016-11-04	Lyndon LIU/ Michael ZHANG	<ol style="list-style-type: none"> <li>Added SGMII and WLAN interfaces in Table 2.</li> <li>Updated function diagram in Figure 1.</li> <li>Updated pin assignment (Top View) in Figure 2.</li> <li>Added description of SGMII and WLAN interfaces in Table 4.</li> <li>Added SGMII interface in Chapter 3.17.</li> <li>Added WLAN interface in Chapter 3.18.</li> <li>Added USB_BOOT interface in Chapter 3.19.</li> <li>Added reference design of RF layout in Chapter 5.1.4.</li> <li>Added current consumption of EC21-V in Chapter</li> </ol>

			6.4.
			10. Added note about SIMO in Chapter 6.6.
1.3	2017-01-24	Lyndon LIU/ Rex WANG	<ol style="list-style-type: none"> <li>1. Updated frequency bands in Table 1.</li> <li>2. Updated function diagram in Figure 1.</li> <li>3. Updated pin assignment (top view) in Figure 2.</li> <li>4. Added BT interface in Chapter 3.18.2.</li> <li>5. Updated reference circuit of wireless connectivity interfaces with FC20 module in Figure 29.</li> <li>6. Updated GNSS performance in Table 24.</li> <li>7. Updated module operating frequencies in Table 26.</li> <li>8. Added EC21-AUV current consumption in Table 38.</li> <li>9. Updated EC21-A conducted RF receiving sensitivity of in Table 42.</li> <li>10. Added EC21-J conducted RF receiving sensitivity in Table 48.</li> </ol>
1.4	2017-03-01	Geely YANG	Deleted the LTE band TDD B41 of EC21-CT

## Contents

About the Document .....	2
Contents .....	4
Table Index .....	6
Figure Index .....	8
<b>1 Introduction .....</b>	<b>10</b>
1.1. Safety Information .....	11
<b>2 Product Concept .....</b>	<b>12</b>
2.1. General Description .....	12
2.2. Key Features .....	13
2.3. Functional Diagram .....	15
2.4. Evaluation Board .....	16
<b>3 Application Interfaces .....</b>	<b>17</b>
3.1. General Description .....	17
3.2. Pin Assignment .....	18
3.3. Pin Description .....	19
3.4. Operating Modes .....	28
3.5. Power Saving .....	28
3.5.1. Sleep Mode .....	28
3.5.1.1. UART Application .....	28
3.5.1.2. USB Application with USB Remote Wakeup Function .....	29
3.5.1.3. USB Application with USB Suspend/Resume and RI Function .....	30
3.5.1.4. USB Application without USB Suspend Function .....	31
3.5.2. Airplane Mode .....	32
3.6. Power Supply .....	32
3.6.1. Power Supply Pins .....	32
3.6.2. Decrease Voltage Drop .....	33
3.6.3. Reference Design for Power Supply .....	34
3.6.4. Monitor the Power Supply .....	35
3.7. Turn on and off Scenarios .....	35
3.7.1. Turn on Module Using the PWRKEY .....	35
3.7.2. Turn off Module .....	37
3.7.2.1. Turn off Module Using the PWRKEY Pin .....	37
3.7.2.2. Turn off Module Using AT Command .....	37
3.8. Reset the Module .....	38
3.9. USIM Card Interface .....	39
3.10. USB Interface .....	41
3.11. UART Interfaces .....	43
3.12. PCM and I2C Interfaces .....	45
3.13. ADC Function .....	48
3.14. Network Status Indication .....	49

3.15.	STATUS .....	50
3.16.	Behavior of the RI .....	51
3.17.	SGMII Interface .....	51
3.18.	Wireless Connectivity Interfaces .....	54
3.18.1.	WLAN Interface .....	56
3.18.2.	BT Interface* .....	56
3.19.	USB_BOOT Interface.....	57
<b>4</b>	<b>GNSS Receiver .....</b>	<b>58</b>
4.1.	General Description .....	58
4.2.	GNSS Performance .....	58
4.3.	Layout Guidelines .....	59
<b>5</b>	<b>Antenna Interfaces .....</b>	<b>60</b>
5.1.	Main/Rx-diversity Antenna Interface .....	60
5.1.1.	Pin Definition.....	60
5.1.2.	Operating Frequency .....	60
5.1.3.	Reference Design of RF Antenna Interface .....	61
5.1.4.	Reference Design of RF Layout.....	62
5.2.	GNSS Antenna Interface.....	64
5.3.	Antenna Installation .....	65
5.3.1.	Antenna Requirement.....	65
5.3.2.	Recommended RF Connector for Antenna Installation.....	66
<b>6</b>	<b>Electrical, Reliability and Radio Characteristics .....</b>	<b>68</b>
6.1.	Absolute Maximum Ratings .....	68
6.2.	Power Supply Ratings.....	68
6.3.	Operating Temperature .....	69
6.4.	Current Consumption .....	70
6.5.	RF Output Power .....	76
6.6.	RF Receiving Sensitivity .....	76
6.7.	Electrostatic Discharge .....	80
<b>7</b>	<b>Mechanical Dimensions.....</b>	<b>81</b>
7.1.	Mechanical Dimensions of the Module.....	81
7.2.	Recommended Footprint.....	83
7.3.	Design Effect Drawings of the Module .....	84
<b>8</b>	<b>Storage, Manufacturing and Packaging.....</b>	<b>85</b>
8.1.	Storage .....	85
8.2.	Manufacturing and Soldering .....	86
8.3.	Packaging .....	87
<b>9</b>	<b>Appendix A References .....</b>	<b>88</b>
<b>10</b>	<b>Appendix B GPRS Coding Schemes .....</b>	<b>92</b>
<b>11</b>	<b>Appendix C GPRS Multi-slot Classes.....</b>	<b>93</b>
<b>12</b>	<b>Appendix D EDGE Modulation and Coding Schemes.....</b>	<b>94</b>

## Table Index

TABLE 1: FREQUENCY BANDS OF EC21 SERIES MODULE.....	12
TABLE 2: KEY FEATURES OF EC21 MODULE.....	13
TABLE 3: I/O PARAMETERS DEFINITION.....	19
TABLE 4: PIN DESCRIPTION.....	19
TABLE 5: OVERVIEW OF OPERATING MODES.....	28
TABLE 6: VBAT AND GND PINS.....	33
TABLE 7: PWRKEY PIN DESCRIPTION.....	35
TABLE 8: RESET_N PIN DESCRIPTION.....	38
TABLE 9: PIN DEFINITION OF THE USIM CARD INTERFACE.....	39
TABLE 10: PIN DESCRIPTION OF USB INTERFACE.....	41
TABLE 11: PIN DEFINITION OF THE MAIN UART INTERFACE.....	43
TABLE 12: PIN DEFINITION OF THE DEBUG UART INTERFACE.....	43
TABLE 13: LOGIC LEVELS OF DIGITAL I/O.....	44
TABLE 14: PIN DEFINITION OF PCM AND I2C INTERFACES.....	46
TABLE 15: PIN DEFINITION OF THE ADC.....	48
TABLE 16: CHARACTERISTIC OF THE ADC.....	48
TABLE 17: PIN DEFINITION OF NETWORK CONNECTION STATUS/ACTIVITY INDICATOR.....	49
TABLE 18: WORKING STATE OF NETWORK CONNECTION STATUS/ACTIVITY INDICATOR.....	49
TABLE 19: PIN DEFINITION OF STATUS.....	50
TABLE 20: BEHAVIOR OF THE RI.....	51
TABLE 21: PIN DEFINITION OF THE SGMII INTERFACE.....	52
TABLE 22: PIN DEFINITION OF WIRELESS CONNECTIVITY INTERFACES.....	54
TABLE 23: PIN DEFINITION OF USB_BOOT INTERFACE.....	57
TABLE 24: GNSS PERFORMANCE.....	58
TABLE 25: PIN DEFINITION OF THE RF ANTENNA.....	60
TABLE 26: MODULE OPERATING FREQUENCIES.....	60
TABLE 27: PIN DEFINITION OF GNSS ANTENNA INTERFACE.....	64
TABLE 28: GNSS FREQUENCY.....	64
TABLE 29: ANTENNA REQUIREMENTS.....	65
TABLE 30: ABSOLUTE MAXIMUM RATINGS.....	68
TABLE 31: POWER SUPPLY RATINGS.....	68
TABLE 32: OPERATING TEMPERATURE.....	69
TABLE 33: EC21-A CURRENT CONSUMPTION.....	70
TABLE 34: EC21-AUT CURRENT CONSUMPTION.....	71
TABLE 35: EC21-E CURRENT CONSUMPTION.....	72
TABLE 36: EC21-KL CURRENT CONSUMPTION.....	73
TABLE 37: EC21-V CURRENT CONSUMPTION.....	74
TABLE 38: EC21-AUV CURRENT CONSUMPTION.....	74
TABLE 39: GNSS CURRENT CONSUMPTION OF EC21 SERIES MODULE.....	75
TABLE 40: RF OUTPUT POWER.....	76
TABLE 41: EC21-E CONDUCTED RF RECEIVING SENSITIVITY.....	76

---

TABLE 42: EC21-A CONDUCTED RF RECEIVING SENSITIVITY .....	77
TABLE 43: EC21-V CONDUCTED RF RECEIVING SENSITIVITY .....	77
TABLE 44: EC21-AUT CONDUCTED RF RECEIVING SENSITIVITY .....	77
TABLE 45: EC21-AUTL CONDUCTED RF RECEIVING SENSITIVITY .....	78
TABLE 46: EC21-KL CONDUCTED RF RECEIVING SENSITIVITY .....	78
TABLE 47: EC21-CT CONDUCTED RF RECEIVING SENSITIVITY .....	78
TABLE 48: EC21-J CONDUCTED RF RECEIVING SENSITIVITY .....	79
TABLE 49: EC21-AUV CONDUCTED RF RECEIVING SENSITIVITY .....	79
TABLE 50: ELECTROSTATIC DISCHARGE CHARACTERISTICS .....	80
TABLE 51: RELATED DOCUMENTS .....	88
TABLE 52: TERMS AND ABBREVIATIONS .....	88
TABLE 53: DESCRIPTION OF DIFFERENT CODING SCHEMES .....	92
TABLE 54: GPRS MULTI-SLOT CLASSES .....	93
TABLE 55: EDGE MODULATION AND CODING SCHEMES .....	94



## Figure Index

FIGURE 1: FUNCTIONAL DIAGRAM .....	16
FIGURE 2: PIN ASSIGNMENT (TOP VIEW) .....	18
FIGURE 3: SLEEP MODE APPLICATION VIA UART .....	29
FIGURE 4: SLEEP MODE APPLICATION WITH USB REMOTE WAKEUP .....	30
FIGURE 5: SLEEP MODE APPLICATION WITH RI .....	31
FIGURE 6: SLEEP MODE APPLICATION WITHOUT SUSPEND FUNCTION .....	31
FIGURE 7: POWER SUPPLY LIMITS DURING BURST TRANSMISSION .....	33
FIGURE 8: STAR STRUCTURE OF THE POWER SUPPLY .....	34
FIGURE 9: REFERENCE CIRCUIT OF POWER SUPPLY .....	34
FIGURE 10: TURN ON THE MODULE USING DRIVING CIRCUIT .....	35
FIGURE 11: TURN ON THE MODULE USING KEYSTROKE .....	36
FIGURE 12: TIMING OF TURNING ON MODULE .....	36
FIGURE 13: TIMING OF TURNING OFF MODULE .....	37
FIGURE 14: REFERENCE CIRCUIT OF RESET_N BY USING DRIVING CIRCUIT .....	38
FIGURE 15: REFERENCE CIRCUIT OF RESET_N BY USING BUTTON .....	38
FIGURE 16: TIMING OF RESETTING MODULE .....	39
FIGURE 17: REFERENCE CIRCUIT OF USIM CARD INTERFACE WITH AN 8-PIN USIM CARD CONNECTOR .....	40
FIGURE 18: REFERENCE CIRCUIT OF USIM CARD INTERFACE WITH A 6-PIN USIM CARD CONNECTOR .....	40
FIGURE 19: REFERENCE CIRCUIT OF USB APPLICATION .....	42
FIGURE 20: REFERENCE CIRCUIT WITH TRANSLATOR CHIP .....	44
FIGURE 21: REFERENCE CIRCUIT WITH TRANSISTOR CIRCUIT .....	45
FIGURE 22: PRIMARY MODE TIMING .....	46
FIGURE 23: AUXILIARY MODE TIMING .....	46
FIGURE 24: REFERENCE CIRCUIT OF PCM APPLICATION WITH AUDIO CODEC .....	47
FIGURE 25: REFERENCE CIRCUIT OF THE NETWORK INDICATOR .....	50
FIGURE 26: REFERENCE CIRCUITS OF STATUS .....	50
FIGURE 27: SIMPLIFIED BLOCK DIAGRAM FOR ETHERNET APPLICATION .....	52
FIGURE 28: REFERENCE CIRCUIT OF SGMII INTERFACE WITH PHY AR8033 APPLICATION .....	53
FIGURE 29: REFERENCE CIRCUIT OF WIRELESS CONNECTIVITY INTERFACES WITH FC20 MODULE .....	55
FIGURE 30: REFERENCE CIRCUIT OF USB_BOOT INTERFACE .....	57
FIGURE 31: REFERENCE CIRCUIT OF RF ANTENNA INTERFACE .....	61
FIGURE 32: MICROSTRIP LINE DESIGN ON A 2-LAYER PCB .....	62
FIGURE 33: COPLANAR WAVEGUIDE LINE DESIGN ON A 2-LAYER PCB .....	62
FIGURE 34: COPLANAR WAVEGUIDE LINE DESIGN ON A 4-LAYER PCB (LAYER 3 AS REFERENCE GROUND) .....	63
FIGURE 35: COPLANAR WAVEGUIDE LINE DESIGN ON A 4-LAYER PCB (LAYER 4 AS REFERENCE GROUND) .....	63
FIGURE 36: REFERENCE CIRCUIT OF GNSS ANTENNA .....	64

---

FIGURE 37: DIMENSIONS OF THE UF.L-R-SMT CONNECTOR (UNIT: MM) .....	66
FIGURE 38: MECHANICALS OF UF.L-LP CONNECTORS .....	66
FIGURE 39: SPACE FACTOR OF MATED CONNECTOR (UNIT: MM) .....	67
FIGURE 40: MODULE TOP AND SIDE DIMENSIONS.....	81
FIGURE 41: MODULE BOTTOM DIMENSIONS (BOTTOM VIEW) .....	82
FIGURE 42: RECOMMENDED FOOTPRINT (TOP VIEW) .....	83
FIGURE 43: TOP VIEW OF THE MODULE .....	84
FIGURE 44: BOTTOM VIEW OF THE MODULE.....	84
FIGURE 45: REFLOW SOLDERING THERMAL PROFILE.....	86
FIGURE 46: TAPE AND REEL SPECIFICATIONS .....	87

# 1 Introduction

This document defines the EC21 module and describes its air interface and hardware interface which are connected with your application.

This document can help you quickly understand module interface specifications, electrical and mechanical details, as well as other related information of EC21 module. Associated with application note and user guide, you can use EC21 module to design and set up mobile applications easily.

## 1.1. Safety Information

The following safety precautions must be observed during all phases of the operation, such as usage, service or repair of any cellular terminal or mobile incorporating EC21 module. Manufacturers of the cellular terminal should send the following safety information to users and operating personnel, and incorporate these guidelines into all manuals supplied with the product. If not so, Quectel assumes no liability for the customer's failure to comply with these precautions.



Full attention must be given to driving at all times in order to reduce the risk of an accident. Using a mobile while driving (even with a handsfree kit) causes distraction and can lead to an accident. You must comply with laws and regulations restricting the use of wireless devices while driving.



Switch off the cellular terminal or mobile before boarding an aircraft. Make sure it is switched off. The operation of wireless appliances in an aircraft is forbidden, so as to prevent interference with communication systems. Consult the airline staff about the use of wireless devices on boarding the aircraft, if your device offers an Airplane Mode which must be enabled prior to boarding an aircraft.



Switch off your wireless device when in hospitals, clinics or other health care facilities. These requests are designed to prevent possible interference with sensitive medical equipment.



Cellular terminals or mobiles operating over radio frequency signal and cellular network cannot be guaranteed to connect in all conditions, for example no mobile fee or with an invalid USIM/SIM card. While you are in this condition and need emergent help, please remember using emergency call. In order to make or receive a call, the cellular terminal or mobile must be switched on and in a service area with adequate cellular signal strength.



Your cellular terminal or mobile contains a transmitter and receiver. When it is ON, it receives and transmits radio frequency energy. RF interference can occur if it is used close to TV set, radio, computer or other electric equipment.



In locations with potentially explosive atmospheres, obey all posted signs to turn off wireless devices such as your phone or other cellular terminals. Areas with potentially explosive atmospheres include fuelling areas, below decks on boats, fuel or chemical transfer or storage facilities, areas where the air contains chemicals or particles such as grain, dust or metal powders, etc.

# 2 Product Concept

## 2.1. General Description

EC21 is a series of LTE-FDD/LTE-TDD/WCDMA/GSM wireless communication module with receive diversity. It provides data connectivity on LTE-FDD, LTE-TDD,DC-HSPA+, HSPA+, HSDPA, HSUPA, WCDMA,EDGE andGPRSnetworks. It also provides GNSS<sup>1)</sup> and voice functionality<sup>2)</sup> for your specific applications.EC21 contains tenvariants:EC21-E, EC21-A, EC21-V, EC21-AUT, EC21-AU,EC21-AUV,EC21-AUTL, EC21-J, EC21-CT and EC21-KL. You can choose a dedicated type based on the region or operator. The following table shows the frequency bands of EC21 series module.

**Table 1: Frequency Bands of EC21 Series Module**

Modules <sup>2)</sup>	LTE Bands	3G Bands	GSM	Rx-diversity	GNSS <sup>1)</sup>
EC21-E	FDD:B1/B3/B5/B7/B8/B20	WCDMA:B1/B5/B8	900/1800	Y	
EC21-A	FDD:B2/B4/B12	WCDMA:B2/B4/B5	N	Y	GPS, GLONASS, BeiDou/
EC21-V	FDD:B4/B13	N	N	Y	Compass, Galileo,QZS
EC21-AUT	FDD:B1/B3/B5/B7/B28	WCDMA: B1/B5	N	Y	S
EC21-AU <sup>3)</sup>	FDD: B1/B2/B3/B4/B5/B7/B8/B28 TDD: B40	WCDMA: B1/B2/B5/B8	850/900/ 1800/1900	Y	
EC21-AUV	FDD: B1/B3/B5/B8/B28	B1/B5/B8	N	Y	N
EC21-AUTL	FDD:B3/B7/B28	N	N	Y	N
EC21-J	FDD: B1/B3/B8/B18/B19/B26	N	N	Y	N
EC21-CT	FDD:B1/B3/B5	N	N	N	N
EC21-KL	FDD:B1/B3/B5/B7/B8	N	N	Y	N

## NOTES

1. <sup>1)</sup> GNSS function is optional.
2. <sup>2)</sup> EC21 series module (EC21-E, EC21-A, EC21-V, EC21-AUT, EC21-AU, EC21-AUV, EC21-AUTL, EC21-J, EC21-CT and EC21-KL) includes **Data-only** and **Telematics** versions. **Data-only** version does not support voice function, while **Telematics** version supports it.
3. <sup>3)</sup> B2 band on EC21-AU module does not support Rx-diversity.
4. Y = supported (including LTE and WCDMA). N = Not supported.

With a compact profile of 32.0mm ×29.0mm ×2.4mm, EC21 can meet almost all requirements for M2M applications such as automotive, metering, tracking system, security, router, wireless POS, mobile computing device, PDA phone, tablet PC, etc.

EC21 is an SMD type module which can be embedded into applications through its 144-pin pads, including 80LCC signal pads and 64 other pads.

## 2.2. Key Features

The following table describes the detailed features of EC21 module.

**Table 2: Key Features of EC21 Module**

Features	Details
Power Supply	Supply voltage: 3.3V~4.3V Typical supply voltage: 3.8V
Transmitting Power	Class 4 (33dBm±2dB) for GSM900 Class 1 (30dBm±2dB) for DCS1800 Class E2 (27dBm±3dB) for GSM900 8-PSK Class E2 (26dBm±3dB) for DCS1800 8-PSK Class 3 (22.5dBm -3/+1dB) for WCDMA bands Class 3 (22.5dBm -3/+1dB) for LTE-FDD bands Class 3 (22.5dBm -3/+1dB) for LTE-TDD bands
LTE Features	Support up to non-CA CAT1 Support 1.4 to 20MHz RF bandwidth Support MIMO in DL direction FDD: Max 5Mbps (UL), 10Mbps (DL) TDD: Max 3.1Mbps(UL), 8.96Mbps(DL)
WCDMA Features	Support 3GPP R8 DC-HSPA+ Support 16-QAM, 64-QAM and QPSK modulation 3GPP R6 CAT6 HSUPA: Max 5.76Mbps (UL)

	3GPP R8 CAT24 DC-HSPA+: Max 42Mbps (DL)
GSMFeatures	<p><b>R99:</b> CSD: 9.6kbps, 14.4kbps</p> <p><b>GPRS:</b> Support GPRS multi-slot class 12 (12 by default) Coding scheme: CS-1, CS-2, CS-3 and CS-4 Maximum of four Rx time slots per frame</p> <p><b>EDGE:</b> Support EDGE multi-slot class 12 (12 by default) Support GMSK and 8-PSK for different MCS (Modulation and Coding Scheme) Downlink coding schemes: CS 1-4 and MCS 1-9 Uplink coding schemes: CS 1-4 and MCS 1-9</p>
Internet Protocol Features	<p>Support TCP/UDP/PPP/FTP/HTTP/NTP/PING/QMI/HTTPS*/SMTP*/MMS*/FTPS*/SSL*protocols Support PAP (Password Authentication Protocol) and CHAP (Challenge Handshake Authentication Protocol) protocols which are usually used for PPP connections</p>
SMS	<p>Text and PDU mode Point to point MO and MT SMS cell broadcast SMS storage: ME by default</p>
USIM Interface	Support USIM/SIM card: 1.8V, 3.0V
Audio Features	<p>Support one digital audio interface: PCM interface GSM: HR/FR/EFR/AMR/AMR-WB WCDMA: AMR/AMR-WB LTE: AMR/AMR-WB Support echo cancellation and noise suppression</p>
PCM Interface	<p>Used for audio function with external codec Support 8-bit A-law*, <math>\mu</math>-law*and 16-bit linear data formats Support long frame synchronization and short frame synchronization Support master and slave modes, but must be the master in long frame synchronization</p>
USB Interface	<p>Compliant with USB 2.0 specification (slave only);the data transfer rate can reach up to 480Mbps Used for AT command communication, data transmission, GNSS NMEA output, software debugging, firmware upgradeand voice over USB* SupportUSB drivers for Windows XP, Windows Vista, Windows 7, Windows 8/8.1, Window 10, Linux 2.6 or later, Android 4.0/4.2/4.4/5.0/5.1/6.0</p>
UART Interface	<p><b>Main UART:</b> Used for AT command communication and data transmission</p>

	Baud rate reach up to 3000000bps, 115200bps by default Support RTS and CTS hardware flow control <b>Debug UART:</b> Used for Linux console, log output 115200bps baud rate
SGMII Interface	Support 10/100/1000Mbps Ethernet connectivity
Wireless Connectivity Interfaces	Support a low-power SDIO 3.0 interface for WLAN and UART/PCM interface for Bluetooth*
Rx-diversity	Support LTE/WCDMA Rx-diversity
GNSS Features	Gen8CLite of Qualcomm Protocol: NMEA 0183
AT Commands	Compliant with 3GPP TS 27.007, 27.005 and Quectel enhanced AT commands
Network Indication	Two pins including NET_MODE and NET_STATUS to indicate network connectivity status
Antenna Interface	Including main antennainterface(ANT_MAIN), Rx-diversity antenna interface (ANT_DIV) and GNSS antenna interface (ANT_GNSS)
Physical Characteristics	Size: (32.0±0.15)×(29.0±0.15)×(2.4±0.2)mm Weight: approx. 4.9g
Temperature Range	Operation temperature range: -35°C ~ +75°C <sup>1)</sup> Extended temperature range: -40°C ~ +85°C <sup>2)</sup>
Firmware Upgrade	USB interfaceand DFOTA*
RoHS	All hardware components are fully compliant with EU RoHS directive

## NOTES

- <sup>1)</sup> Within operating temperature range, the module is 3GPP compliant.
- <sup>2)</sup> Within extended temperature range, the module remains the ability to establish and maintain a voice, SMS, data transmission, emergency call, etc. There is no unrecoverable malfunction. There are also no effects on radio spectrum and no harm to radio network. Only one or more parameters like P<sub>out</sub> might reduce in their value and exceed the specified tolerances. When the temperature returns to normal operating temperature levels, the module will meet 3GPP specifications again.
- “\*” means under development.

## 2.3. Functional Diagram



The following figure shows a block diagram of EC21 and illustrates the major functional parts.

- Power management
- Baseband
- DDR+NAND flash
- Radio frequency
- Peripheral interfaces

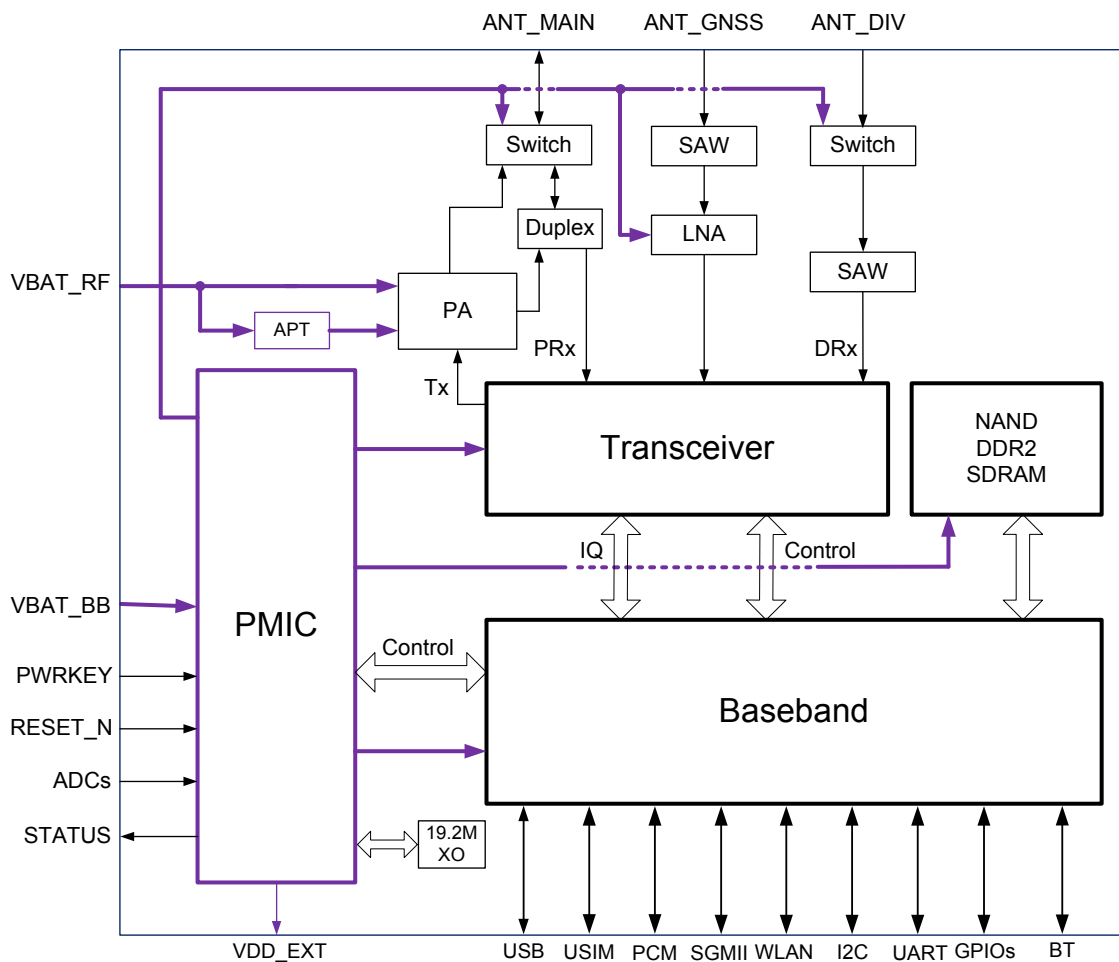


Figure 1: Functional Diagram

## 2.4. Evaluation Board

In order to help you develop applications with EC21, Quectel supplies an evaluation board (EVB), USB data cable, earphone, antenna and other peripherals to control or test the module.

# 3 Application Interfaces

## 3.1. General Description

EC21 is equipped with 80-pin SMT pads plus 64-pin ground pads and reserved pads that can be connected to cellular application platform. Sub-interfaces included in these pads are described in detail in the following chapters:

- Power supply
- USIM interface
- USB interface
- UART interfaces
- PCM interface
- ADC interface
- Status indication
- SGMII interface
- Wireless connectivity interfaces
- USB\_BOOT interface

### 3.2. Pin Assignment

The following figure shows the pin assignment of EC21 module.

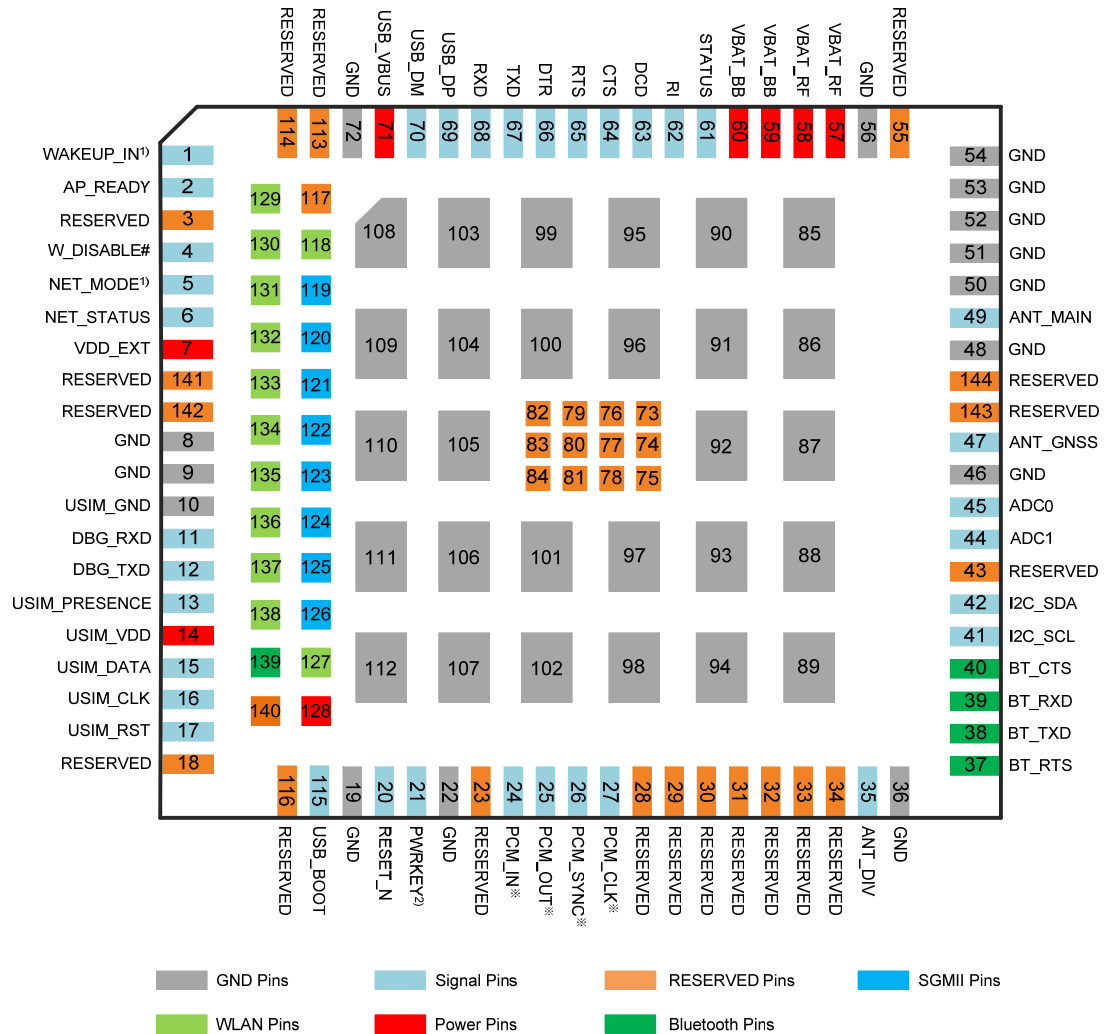


Figure 2: Pin Assignment (Top View)

**NOTES**

- <sup>1)</sup>means that these pins cannot be pulled up before startup.
- <sup>2)</sup> PWRKEY output voltage is 0.8V because of the diode drop in the Qualcomm chipset.
- Pads 119~126 are SGMII function pins.
- Pads 37~40, 118, 127 and 129~139 are wireless connectivity interfaces, among which pads 127 and 129~138 are WLAN function pins, and others are Bluetooth (BT) function pins. BT function is under development.
- Pads 24~27 are multiplexing pins used for audio design on EC21 module and BT function on FC20

module.

6. Keep all RESERVED pins and unused pins unconnected.
7. GND pads 85~112 should be connected to ground in the design, and RESERVED pads 73~84 should not be designed in schematic and PCB decal.
8. “\*” means these interface functions are only supported on **Telematics** version.

### 3.3. Pin Description

The following tables show the pin definition of EC21 module.

**Table 3: I/O Parameters Definition**

Type	Description
IO	Bidirectional
DI	Digital input
DO	Digital output
PI	Power input
PO	Power output
AI	Analog input
AO	Analog output
OD	Open drain

**Table 4: Pin Description**

Power Supply					
Pin Name	Pin No.	I/O	Description	DC Characteristics	Comment
VBAT_BB	59,60	PI	Power supply for module baseband part	Vmax=4.3V Vmin=3.3V Vnorm=3.8V	It must be able to provide sufficient current up to 0.8A.
VBAT_RF	57,58	PI	Power supply for module RF part	Vmax=4.3V Vmin=3.3V Vnorm=3.8V	It must be able to provide sufficient current up to 1.8A in a burst transmission.

VDD_EXT	7	PO	Provide 1.8V for external circuit	Vnorm=1.8V I <sub>O</sub> max=50mA	Power supply for external GPIO's pull up circuits.
GND	8,9,19,22,3 6,46,48,50 ~54,56,72, 85~112		Ground		

#### Turn on/off

Pin Name	Pin No.	I/O	Description	DC Characteristics	Comment
PWRKEY	21	DI	Turnon/off the module	V <sub>IH</sub> max=2.1V V <sub>IH</sub> min=1.3V V <sub>IL</sub> max=0.5V	The output voltage is 0.8V because of the diode drop in the Qualcomm chipset.
RESET_N	20	DI	Reset the module	V <sub>IH</sub> max=2.1V V <sub>IH</sub> min=1.3V V <sub>IL</sub> max=0.5V	

#### Status Indication

Pin Name	Pin No.	I/O	Description	DC Characteristics	Comment
STATUS	61	OD	Indicate the module operating status	The drive current should be less than 0.9mA.	Require external pull-up. If unused, keep it open.
NET_MODE	5	DO	Indicate the module network registration mode	V <sub>OH</sub> min=1.35V V <sub>OL</sub> max=0.45V	1.8V power domain. Cannot be pulled up before startup. If unused, keep it open.
NET_STATUS	6	DO	Indicate the module network activity status	V <sub>OH</sub> min=1.35V V <sub>OL</sub> max=0.45V	1.8V power domain. If unused, keep it open.

#### USB Interface

Pin Name	Pin No.	I/O	Description	DC Characteristics	Comment
USB_VBUS	71	PI	USB detection	Vnorm=5.0V	
USB_DP	69	IO	USB differential data bus	Compliant with USB 2.0 standard specification.	Require differential impedance of 90ohm.
USB_DM	70	IO	USB differential data bus	Compliant with USB 2.0 standard specification.	Require differential impedance of 90ohm.

**USIM Interface**

Pin Name	Pin No.	I/O	Description	DC Characteristics	Comment
USIM_GND	10		Specified ground for USIM card		
USIM_VDD	14	PO	Power supply for USIM card	For 1.8V USIM: V <sub>max</sub> =1.9V V <sub>min</sub> =1.7V  For 3.0V USIM: V <sub>max</sub> =3.05V V <sub>min</sub> =2.7V I <sub>o</sub> max=50mA	Either 1.8V or 3.0V is supported by the module automatically.
USIM_DATA	15	IO	Data signal of USIM card	For 1.8V USIM: V <sub>IL</sub> max=0.6V V <sub>IH</sub> min=1.2V V <sub>OL</sub> max=0.45V V <sub>OH</sub> min=1.35V  For 3.0V USIM: V <sub>IL</sub> max=1.0V V <sub>IH</sub> min=1.95V V <sub>OL</sub> max=0.45V V <sub>OH</sub> min=2.55V	
USIM_CLK	16	DO	Clock signal of USIM card	For 1.8V USIM: V <sub>OL</sub> max=0.45V V <sub>OH</sub> min=1.35V  For 3.0V USIM: V <sub>OL</sub> max=0.45V V <sub>OH</sub> min=2.55V	
USIM_RST	17	DO	Reset signal of USIM card	For 1.8V USIM: V <sub>OL</sub> max=0.45V V <sub>OH</sub> min=1.35V  For 3.0V USIM: V <sub>OL</sub> max=0.45V V <sub>OH</sub> min=2.55V	
USIM_PRESENCE	13	DI	USIM card insertion detection	V <sub>IL</sub> min=-0.3V V <sub>IL</sub> max=0.6V V <sub>IH</sub> min=1.2V V <sub>IH</sub> max=2.0V	1.8V power domain. If unused, keep it open.

### UART Interface

Pin Name	Pin No.	I/O	Description	DC Characteristics	Comment
RI	62	DO	Ring indicator	$V_{OLmax}=0.45V$ $V_{OHmin}=1.35V$	1.8V power domain. If unused, keep it open.
DCD	63	DO	Data carrier detection	$V_{OLmax}=0.45V$ $V_{OHmin}=1.35V$	1.8V power domain. If unused, keep it open.
CTS	64	DO	Clear to send	$V_{OLmax}=0.45V$ $V_{OHmin}=1.35V$	1.8V power domain. If unused, keep it open.
RTS	65	DI	Request to send	$V_{ILmin}=-0.3V$ $V_{ILmax}=0.6V$ $V_{IHmin}=1.2V$ $V_{IHmax}=2.0V$	1.8V power domain. If unused, keep it open.
DTR	66	DI	Data terminal ready,sleep mode control	$V_{ILmin}=-0.3V$ $V_{ILmax}=0.6V$ $V_{IHmin}=1.2V$ $V_{IHmax}=2.0V$	1.8V power domain. Pull-up by default. Low level wakes up the module. If unused, keep it open.
TXD	67	DO	Transmit data	$V_{OLmax}=0.45V$ $V_{OHmin}=1.35V$	1.8V power domain. If unused, keep it open.
RXD	68	DI	Receive data	$V_{ILmin}=-0.3V$ $V_{ILmax}=0.6V$ $V_{IHmin}=1.2V$ $V_{IHmax}=2.0V$	1.8V power domain. If unused, keep it open.

### Debug UART Interface

Pin Name	Pin No.	I/O	Description	DC Characteristics	Comment
DBG_TXD	12	DO	Transmit data	$V_{OLmax}=0.45V$ $V_{OHmin}=1.35V$	1.8V power domain. If unused, keep it open.
DBG_RXD	11	DI	Receive data	$V_{ILmin}=-0.3V$ $V_{ILmax}=0.6V$ $V_{IHmin}=1.2V$ $V_{IHmax}=2.0V$	1.8V power domain. If unused, keep it open.

### ADC Interface

Pin Name	Pin No.	I/O	Description	DC Characteristics	Comment
ADC0	45	AI	General purpose analog to digital converter	Voltage range: 0.3V to VBAT_BB	If unused, keep it open.
ADC1	44	AI	General purpose analog to digital converter	Voltage range: 0.3V to VBAT_BB	If unused, keep it open.

### PCM Interface

Pin Name	Pin No.	I/O	Description	DC Characteristics	Comment
PCM_IN	24	DI	PCM data input	$V_{ILmin}=-0.3V$ $V_{ILmax}=0.6V$ $V_{IHmin}=1.2V$ $V_{IHmax}=2.0V$	1.8V power domain. If unused, keep it open.
PCM_OUT	25	DO	PCM data output	$V_{OLmax}=0.45V$ $V_{OHmin}=1.35V$	1.8V power domain. If unused, keep it open.
PCM_SYNC	26	IO	PCM data frame synchronization signal	$V_{OLmax}=0.45V$ $V_{OHmin}=1.35V$ $V_{ILmin}=-0.3V$ $V_{ILmax}=0.6V$ $V_{IHmin}=1.2V$ $V_{IHmax}=2.0V$	1.8V power domain. In master mode, it is an output signal. In slave mode, it is an input signal. If unused, keep it open.
PCM_CLK	27	IO	PCM clock	$V_{OLmax}=0.45V$ $V_{OHmin}=1.35V$ $V_{ILmin}=-0.3V$ $V_{ILmax}=0.6V$ $V_{IHmin}=1.2V$ $V_{IHmax}=2.0V$	1.8V power domain. In master mode, it is an output signal. In slave mode, it is an input signal. If unused, keep it open.

### I2C Interface

Pin Name	Pin No.	I/O	Description	DC Characteristics	Comment
I2C_SCL	41	OD	I2C serial clock. Used for external codec		External pull-up resistor is required. 1.8V only. If unused, keep it open.
I2C_SDA	42	OD	I2C serial data. Used for external codec		External pull-up resistor is required. 1.8V only. If unused, keep it open.

### SGMII Interface

Pin Name	Pin No.	I/O	Description	DC Characteristics	Comment
EPHY_RST_N	119	DO	Ethernet PHY reset	For 1.8V: $V_{OLmax}=0.45V$ $V_{OHmin}=1.4V$  For 2.85V: $V_{OLmax}=0.35V$ $V_{OHmin}=2.14V$	1.8V/2.85V power domain. If unused, keep it open.



EPHY_INT_N	120	DI	Ethernet PHY interrupt	V <sub>IL</sub> min=-0.3V V <sub>IL</sub> max=0.6V V <sub>IH</sub> min=1.2V V <sub>IH</sub> max=2.0V	1.8V power domain. If unused, keep it open.
SGMII_MDATA	121	IO	SGMII MDIO (Management Data Input/Output) data	For 1.8V: V <sub>OL</sub> max=0.45V V <sub>OH</sub> min=1.4V V <sub>IL</sub> max=0.58V V <sub>IH</sub> min=1.27V For 2.85V: V <sub>OL</sub> max=0.35V V <sub>OH</sub> min=2.14V V <sub>IL</sub> max=0.71V V <sub>IH</sub> min=1.78V	1.8V/2.85V power domain. If unused, keep it open.
SGMII_MCLK	122	DO	SGMII MDIO (Management Data Input/Output) clock	For 1.8V: V <sub>OL</sub> max=0.45V V <sub>OH</sub> min=1.4V For 2.85V: V <sub>OL</sub> max=0.35V V <sub>OH</sub> min=2.14V	1.8V/2.85V power domain. If unused, keep it open.
USIM2_VDD	128	PO	SGMII MDIO pull-up power source		Configurable power source. 1.8V/2.85V power domain. External pull-up for SGMII MDIO pins. If unused, keep it open.
SGMII_TX_M	123	AO	SGMII transmission - minus		If unused, keep it open.
SGMII_TX_P	124	AO	SGMII transmission - plus		If unused, keep it open.
SGMII_RX_P	125	AI	SGMII receiving - plus		If unused, keep it open.
SGMII_RX_M	126	AI	SGMII receiving -minus		If unused, keep it open.

#### Wireless Connectivity Interfaces

Pin Name	Pin No.	I/O	Description	DC Characteristics	Comment
SDC1_DATA3	129	IO	SDIO data bus D3	V <sub>OL</sub> max=0.45V V <sub>OH</sub> min=1.35V	1.8V power domain. If unused, keep it

				V <sub>IL</sub> min=-0.3V V <sub>IL</sub> max=0.6V V <sub>IH</sub> min=1.2V V <sub>IH</sub> max=2.0V	open.
SDC1_ DATA2	130	IO	SDIO data bus D2	V <sub>OL</sub> max=0.45V V <sub>OH</sub> min=1.35V V <sub>IL</sub> min=-0.3V V <sub>IL</sub> max=0.6V V <sub>IH</sub> min=1.2V V <sub>IH</sub> max=2.0V	1.8V power domain. If unused, keep it open.
SDC1_ DATA1	131	IO	SDIO data bus D1	V <sub>OL</sub> max=0.45V V <sub>OH</sub> min=1.35V V <sub>IL</sub> min=-0.3V V <sub>IL</sub> max=0.6V V <sub>IH</sub> min=1.2V V <sub>IH</sub> max=2.0V	1.8V power domain. If unused, keep it open.
SDC1_ DATA0	132	IO	SDIO data bus D1	V <sub>OL</sub> max=0.45V V <sub>OH</sub> min=1.35V V <sub>IL</sub> min=-0.3V V <sub>IL</sub> max=0.6V V <sub>IH</sub> min=1.2V V <sub>IH</sub> max=2.0V	1.8V power domain. If unused, keep it open.
SDC1_CLK	133	DO	SDIO clock	V <sub>OL</sub> max=0.45V V <sub>OH</sub> min=1.35V	1.8V power domain. If unused, keep it open.
SDC1_CMD	134	DO	SDIO command	V <sub>OL</sub> max=0.45V V <sub>OH</sub> min=1.35V	1.8V power domain. If unused, keep it open.
PM_ENABLE	127	DO	External power control	V <sub>OL</sub> max=0.45V V <sub>OH</sub> min=1.35V	1.8V power domain. If unused, keep it open.
WAKE_ON_ WIRELESS	135	DI	Wake up the host (EC21 module) by FC20 module.	V <sub>IL</sub> min=-0.3V V <sub>IL</sub> max=0.6V V <sub>IH</sub> min=1.2V V <sub>IH</sub> max=2.0V	1.8V power domain. Active low. If unused, keep it open.
WLAN_EN	136	DO	WLAN function control via FC20 module	V <sub>OL</sub> max=0.45V V <sub>OH</sub> min=1.35V	1.8V power domain. Active high. If unused, keep it open.
COEX_UART_ RX	137	DI	LTE/WLAN coexistence signal	V <sub>IL</sub> min=-0.3V V <sub>IL</sub> max=0.6V V <sub>IH</sub> min=1.2V V <sub>IH</sub> max=2.0V	1.8V power domain. If unused, keep it open.

COEX_UART_TX	138	DO	LTE/WLAN coexistence signal	$V_{OLmax}=0.45V$ $V_{OHmin}=1.35V$	1.8V power domain. If unused, keep it open.
WLAN_SLP_CLK	118	DO	WLAN sleep clock		If unused, keep it open.
BT_RTS*	37	DI	BT UART request to send	$V_{ILmin}=-0.3V$ $V_{ILmax}=0.6V$ $V_{IHmin}=1.2V$ $V_{IHmax}=2.0V$	1.8V power domain. If unused, keep it open.
BT_TXD*	38	DO	BT UART transmit data	$V_{OLmax}=0.45V$ $V_{OHmin}=1.35V$	1.8V power domain. If unused, keep it open.
BT_RXD*	39	DI	BT UART receive data	$V_{ILmin}=-0.3V$ $V_{ILmax}=0.6V$ $V_{IHmin}=1.2V$ $V_{IHmax}=2.0V$	1.8V power domain. If unused, keep it open.
BT_CTS*	40	DO	BT UART clear to send	$V_{OLmax}=0.45V$ $V_{OHmin}=1.35V$	1.8V power domain. If unused, keep it open.
BT_EN*	139	DO	BTfunctioncontrolvia FC20 module	$V_{OLmax}=0.45V$ $V_{OHmin}=1.35V$	1.8V power domain. If unused, keep it open.

#### RF Interface

Pin Name	Pin No.	I/O	Description	DC Characteristics	Comment
ANT_DIV	35	AI	Diversity antenna pad	50ohm impedance	If unused, keep it open.
ANT_MAIN	49	IO	Main antenna pad	50ohm impedance	
ANT_GNSS	47	AI	GNSS antenna pad	50 ohm impedance	If unused, keep it open.

#### GPIO Pins

Pin Name	Pin No.	I/O	Description	DC Characteristics	Comment
WAKEUP_IN	1	DI	Sleep mode control	$V_{ILmin}=-0.3V$ $V_{ILmax}=0.6V$ $V_{IHmin}=1.2V$ $V_{IHmax}=2.0V$	1.8V power domain. Cannot be pulled up before startup. Low level wakes up the module. If unused, keep it open.
W_DISABLE#	4	DI	Airplane mode	$V_{ILmin}=-0.3V$	1.8V power domain.

			control	$V_{ILmax}=0.6V$ $V_{IHmin}=1.2V$ $V_{IHmax}=2.0V$	Pull-up by default. In low voltage level, module can enter into airplane mode. If unused, keep it open.
AP_READY	2	DI	Application processor sleep state detection	$V_{ILmin}=-0.3V$ $V_{ILmax}=0.6V$ $V_{IHmin}=1.2V$ $V_{IHmax}=2.0V$	1.8V power domain. If unused, keep it open.

#### Other Interface Pins

Pin Name	Pin No.	I/O	Description	DC Characteristics	Comment
USB_BOOT	115	DI	Force the module to boot from USB port.	$V_{ILmin}=-0.3V$ $V_{ILmax}=0.6V$ $V_{IHmin}=1.2V$ $V_{IHmax}=2.0V$	1.8V power domain. If unused, keep it open.

#### RESERVED Pins

Pin Name	Pin No.	I/O	Description	DC Characteristics	Comment
RESERVED	3, 18, 23, 28~34, 43, 55, 73~84, 113, 114, 116, 117, 140~144		Reserved		Keep these pins unconnected.

#### NOTES

1. “\*” means under development.
2. Pads 24~27 are multiplexing pins used for audio design on EC21 module and BT function on FC20 module.

## 3.4. Operating Modes

The table below briefly summarizes the various operating modes referred in the following chapters.

**Table 5: Overview of Operating Modes**

Mode	Details	
Normal Operation	Idle	Software is active. The module has been registered on the network, and it is ready to send and receive data.
	Talk/Data	Network connection is ongoing. In this mode, the power consumption is decided by network setting and data transfer rate.
Minimum Functionality Mode	<b>AT+CFUN</b> command can set the module to a minimum functionality mode without removing the power supply. In this case, both RF function and USIM card will be invalid.	
Airplane Mode	<b>AT+CFUN</b> command or W_DISABLE# pin can set the module to airplane mode. In this case, RF function will be invalid.	
Sleep Mode	In this mode, the current consumption of the module will be reduced to the minimal level. During this mode, the module can still receive paging message, SMS, voice call and TCP/UDP data from the network normally.	
Power down Mode	In this mode, the power management unit shuts down the power supply. Software is not active. The serial interface is not accessible. Operating voltage (connected to VBAT_RF and VBAT_BB) remains applied.	

## 3.5. Power Saving

### 3.5.1. Sleep Mode

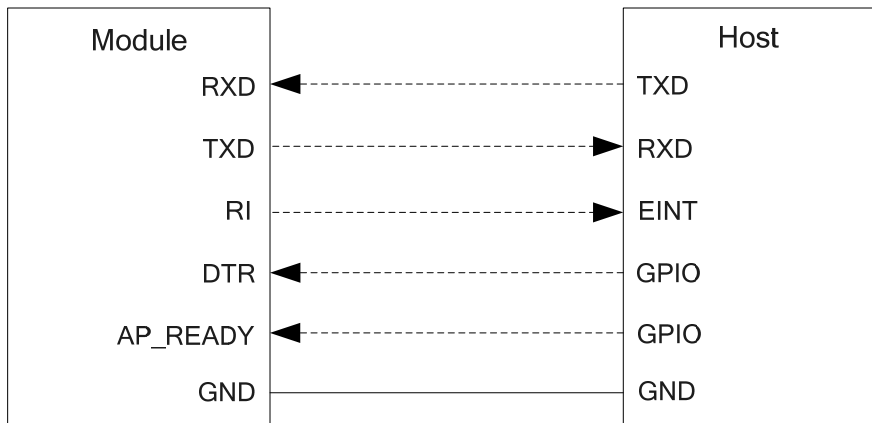
EC21 is able to reduce its current consumption to a minimum value during the sleep mode. The following section describes power saving procedure of EC21 module.

#### 3.5.1.1. UART Application

If the host communicates with module via UART interface, the following preconditions can let the module enter into sleep mode.

- Execute **AT+QSCLK=1** command to enable sleep mode.
- Drive DTR to high level.

The following figure shows the connection between the module and the host.



**Figure 3: Sleep Mode Application via UART**

- Driving the host DTR to low level will wake up the module.
- When EC21 has URC to report, RI signal will wake up the host. Refer to **Chapter 3.16** for details about RI behavior.
- AP\_READY will detect the sleep state of the host (can be configured to high level or low level detection). Please refer to **AT+QCFG="apready"** command for details.

**NOTE**

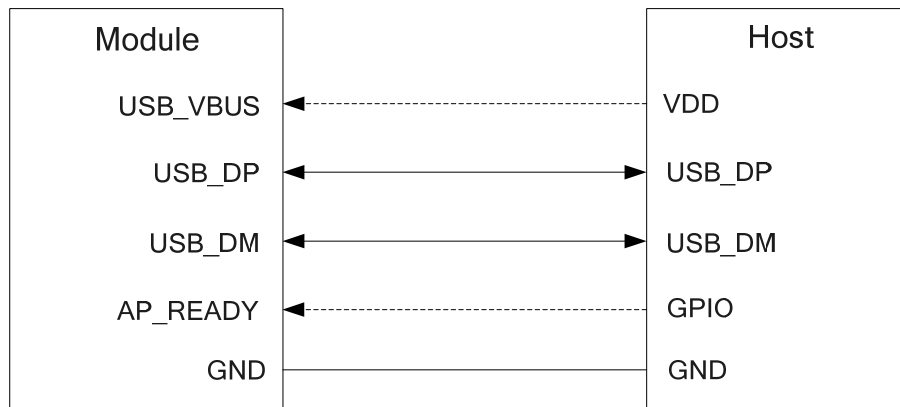
**AT+QCFG="apready"** command is under development.

### 3.5.1.2. USB Application with USB Remote Wakeup Function

If the host supports USB suspend/resume and remote wakeup functions, the following three preconditions must be met to let the module enter into sleep mode.

- Execute **AT+QSCLK=1** command to enable sleep mode.
- Ensure the DTR is held in high level or keep it open.
- The host's USB bus, which is connected with the module's USB interface, enters into suspended state.

The following figure shows the connection between the module and the host.



**Figure 4: Sleep Mode Application with USB Remote Wakeup**

- Sending data to EC21 through USB will wake up the module.
- When EC21 has URC to report, the module will send remote wake-up signals via USB bus so as to wake up the host.

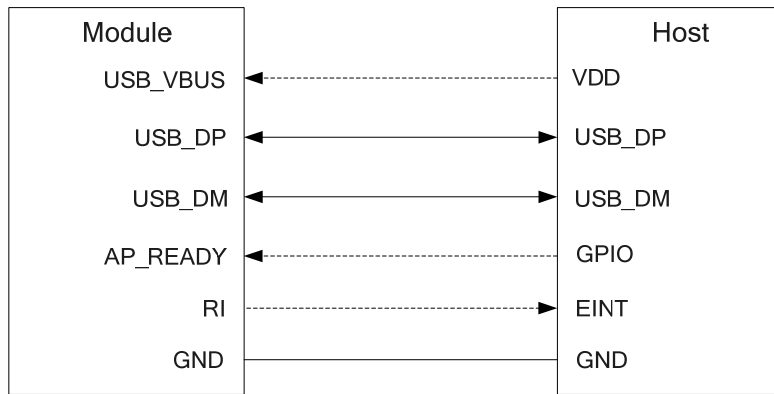
### 3.5.1.3. USB Application with USB Suspend/Resume and RI Function

If the host supports USB suspend/resume, but does not support remote wake-up function, the RI signal is needed to wake up the host.

There are three preconditions to let the module enter into the sleep mode.

- Execute **AT+QSClk=1** command to enable sleep mode.
- Ensure the DTR is held in high level or keep it open.
- The host's USB bus, which is connected with the module's USB interface, enters into suspended state.

The following figure shows the connection between the module and the host.



**Figure 5: Sleep Mode Application with RI**

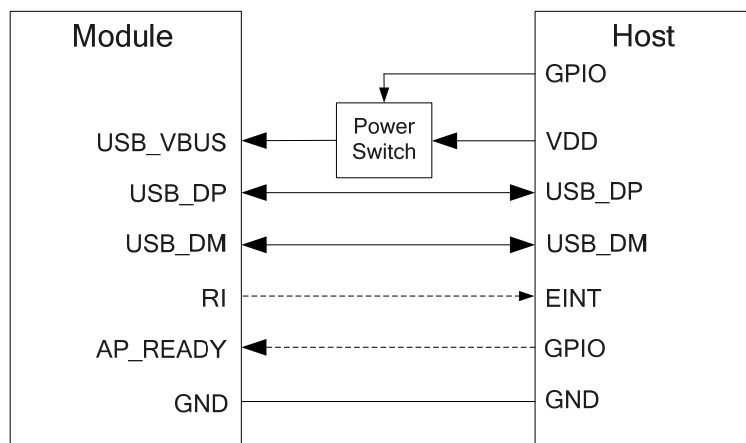
- Sending data to EC21 through USB will wake up the module.
- When EC21 has URC to report, RI signal will wake up the host.

#### 3.5.1.4. USB Application without USB Suspend Function

If the host does not support USB suspend function, you should disconnect USB\_VBUS with additional control circuit to let the module enter into sleep mode.

- Execute **AT+QSCLK=1** command to enable sleep mode.
- Ensure the DTR is held in high level or keep it open.
- Disconnect USB\_VBUS.

The following figure shows the connection between the module and the host.



**Figure 6: Sleep Mode Application without Suspend Function**



Switching on the power switch to supply power to USB\_VBUS will wake up the module.

#### NOTE

Please pay attention to the level match shown in dotted line between the module and the host. Refer to **document [1]** for more details about EC21 power management application.

### 3.5.2. Airplane Mode

When the module enters into airplane mode, the RF function does not work, and all AT commands correlative with RF function will be inaccessible. This mode can be set via the following ways.

#### Hardware:

The W\_DISABLE# pin is pulled up by default; driving it to low level will let the module enter into airplane mode.

#### Software:

**AT+CFUN** command provides the choice of the functionality level.

- **AT+CFUN=0**: Minimum functionality mode; both USIM and RF functions are disabled.
- **AT+CFUN=1**: Full functionality mode (by default).
- **AT+CFUN=4**: Airplane mode. RF function is disabled.

#### NOTES

1. The W\_DISABLE# control function is disabled in firmware by default. It can be enabled by **AT+QCFG="airplanecontrol"** command. This command is under development.
2. The execution of **AT+CFUN** command will not affect GNSS function.

## 3.6. Power Supply

### 3.6.1. Power Supply Pins

EC21 provides four VBAT pins for connection with the external power supply. There are two separate voltage domains for VBAT.

- Two VBAT\_RF pins for module RF part.
- Two VBAT\_BB pins for module baseband part.

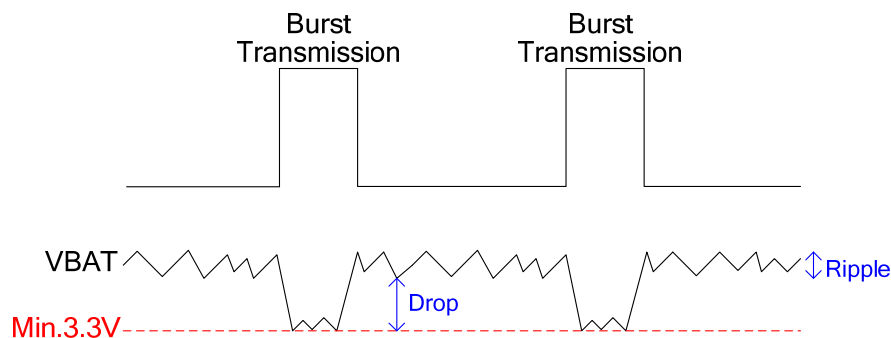
The following table shows the details of VBAT pins and ground pins.

**Table 6: VBAT and GND Pins**

Pin Name	Pin No.	Description	Min.	Typ.	Max.	Unit
VBAT_RF	57,58	Power supply for module RF part.	3.3	3.8	4.3	V
VBAT_BB	59,60	Power supply for module baseband part.	3.3	3.8	4.3	V
GND	8,9,19,22,36,46 , 48,50~54,56, 72, 85~112	Ground	-	0	-	V

### 3.6.2. Decrease Voltage Drop

The power supply range of the module is from 3.3V to 4.3V. Please make sure that the input voltage will never drop below 3.3V. The following figure shows the voltage drop during burst transmission in 2G network. The voltage drop will be less in 3G and 4G networks.



**Figure 7: Power Supply Limits during Burst Transmission**

To decrease voltage drop, a bypass capacitor of about 100 $\mu$ F with low ESR should be used, and a multi-layer ceramic chip (MLCC) capacitor array should also be used to provide the low ESR. The main power supply from an external application has to be a single voltage source and can be expanded to two sub paths with star structure. The width of VBAT\_BB trace should be no less than 1mm; and the width of VBAT\_RF trace should be no less than 2mm. In principle, the longer the VBAT trace is, the wider it will be.

Three ceramic capacitors (100nF, 33pF, 10pF) are recommended to be applied to the VBAT pins. These capacitors should be placed close to the VBAT pins. In addition, in order to get a stable power source, it is suggested that you should use a zener diode of which reverse zener voltage is 5.1V and dissipation power is more than 0.5W. The following figure shows the star structure of the power supply.

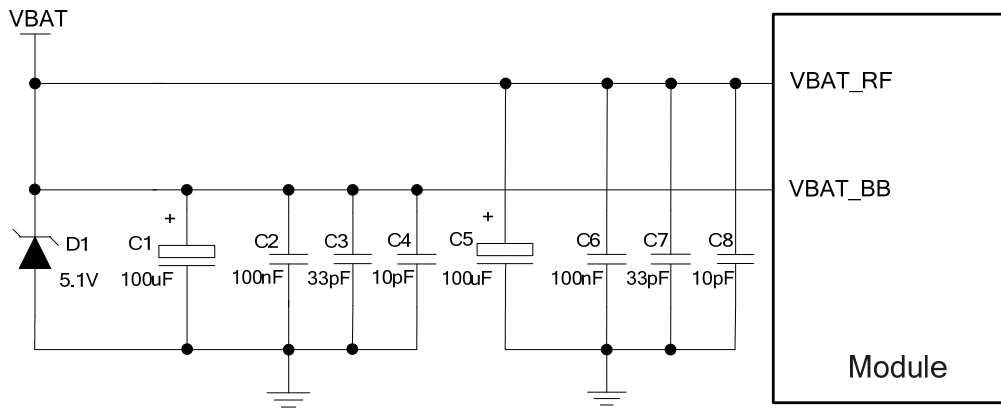


Figure 8: Star Structure of the Power Supply

### 3.6.3. Reference Design for Power Supply

Power design for the module is very important, as the performance of the module largely depends on the power source. The power supply is capable of providing sufficient current up to 2A at least. If the voltage drop between the input and output is not too high, it is suggested that you should use an LDO to supply power for the module. If there is a big voltage difference between the input source and the desired output (VBAT), a buck converter is preferred to be used as the power supply.

The following figure shows a reference design for +5V input power source. The typical output of the power supply is about 3.8V and the maximum load current is 3A.

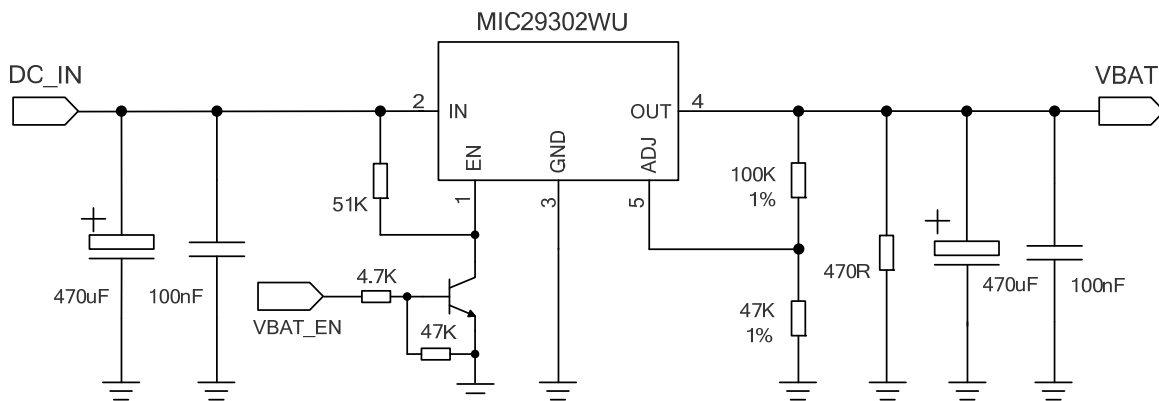


Figure 9: Reference Circuit of Power Supply

**NOTE**

In order to avoid damaging internal flash, please do not switch off the power supply when the module works normally. Only after the module is shutdown by PWRKEY or AT command, the power supply can be cut off.

### 3.6.4. Monitor the Power Supply

**AT+CBC** command can be used to monitor the VBAT\_BB voltage value. For more details, please refer to *document [2]*.

## 3.7. Turn on and off Scenarios

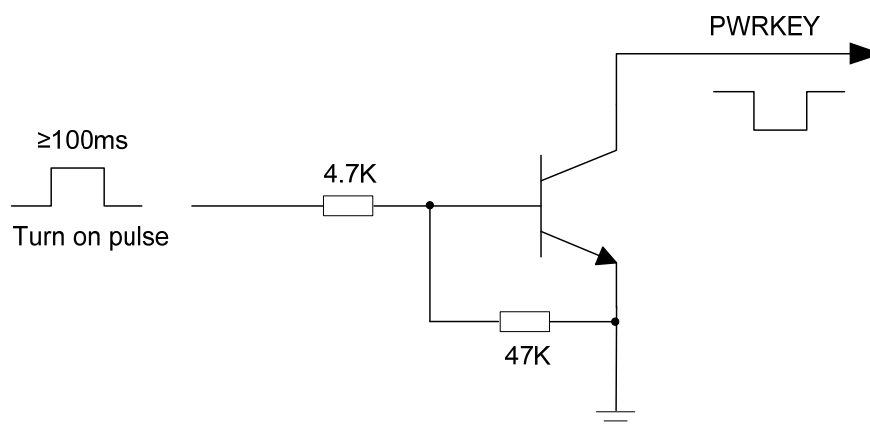
### 3.7.1. Turn on Module Using the PWRKEY

The following table shows the pin definition of PWRKEY.

**Table 7: PWRKEY Pin Description**

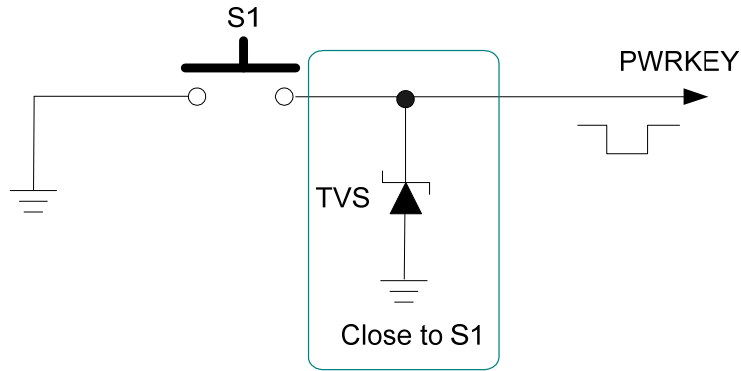
Pin Name	Pin No.	Description	DC Characteristics	Comment
PWRKEY	21	Turn on/off the module	$V_{IHmax}=2.1V$ $V_{IHmin}=1.3V$ $V_{ILmax}=0.5V$	The output voltage is 0.8V because of the diode drop in the Qualcomm chipset.

When EC21 is in power down mode, it can be turned on to normal mode by driving the PWRKEY pin to a low level for at least 100ms. It is recommended to use an open drain/collector driver to control the PWRKEY. After STATUS pin (require external pull-up) outputting a low level, PWRKEY pin can be released. A simple reference circuit is illustrated in the following figure.



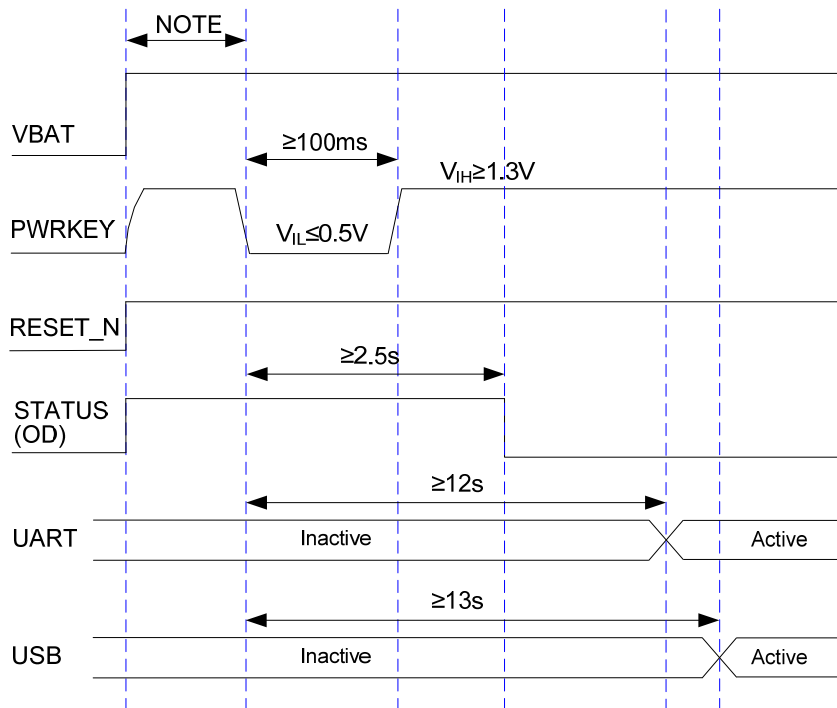
**Figure 10: Turn on the Module Using Driving Circuit**

The other way to control the PWRKEY is using a button directly. When pressing the key, electrostatic strike may generate from finger. Therefore, a TVS component is indispensable to be placed nearby the button for ESD protection. A reference circuit is shown in the following figure.



**Figure 11: Turn on the Module Using Keystroke**

The turn on scenario is illustrated in the following figure.



**Figure 12: Timing of Turning on Module**

**NOTE**

Please make sure that VBAT is stable before pulling down PWRKEY pin. The time between them is no less than 30ms.

### 3.7.2. Turn off Module

The following procedures can be used to turn off the module:

- Normal power down procedure: Turn off the module using the PWRKEY pin.
- Normal power down procedure: Turn off the module using **AT+QPOWD** command.

#### 3.7.2.1. Turn off Module Using the PWRKEY Pin

Driving the PWRKEY pin to a low level voltage for at least 650ms, the module will execute power-down procedure after the PWRKEY is released. The power-down scenario is illustrated in the following figure.

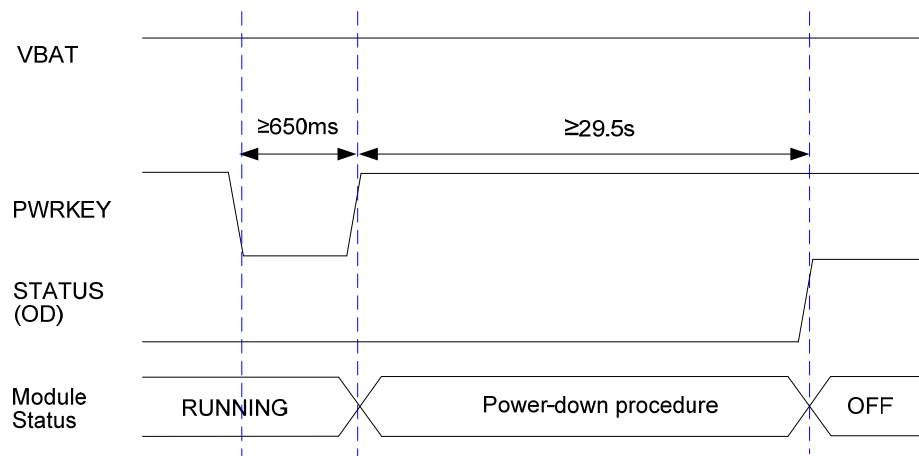


Figure 13: Timing of Turning off Module

#### 3.7.2.2. Turn off Module Using AT Command

It is also a safe way to use **AT+QPOWD** command to turn off the module, which is similar to turning off the module via PWRKEY pin.

Please refer to *document [2]* for details about **AT+QPOWD** command.

#### NOTE

In order to avoid damaging internal flash, please do not switch off the power supply when the module works normally. Only after the module is shutdown by PWRKEY or AT command, the power supply can be cut off.

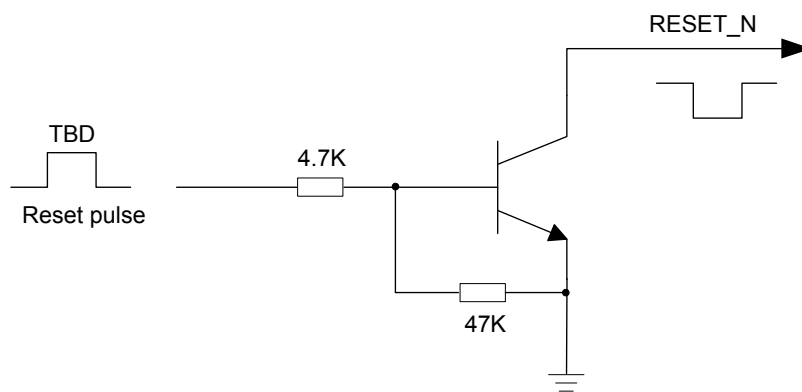
### 3.8. Reset the Module

The RESET\_N pin can be used to reset the module. The module can be reset by driving RESET\_N to a low level voltage for time between 150ms and 460ms.

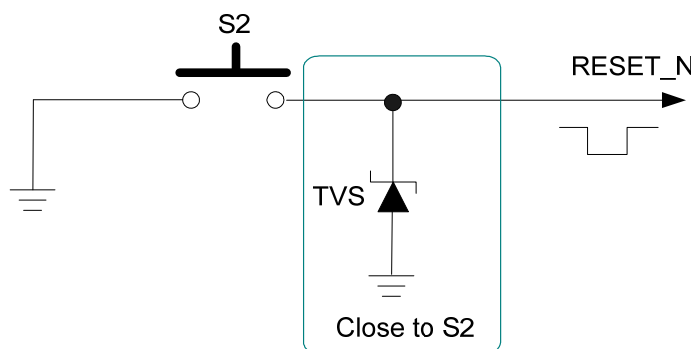
**Table 8: RESET\_N Pin Description**

Pin Name	Pin No.	Description	DC Characteristics	Comment
RESET_N	20	Reset the module	$V_{IHmax}=2.1V$ $V_{IHmin}=1.3V$ $V_{ILmax}=0.5V$	

The recommended circuit is similar to the PWRKEY control circuit. An open drain/collector driver or button can be used to control the RESET\_N.

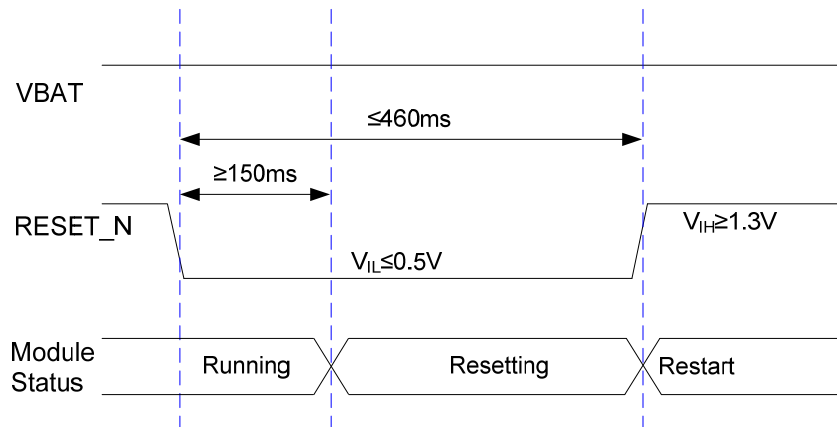


**Figure 14: Reference Circuit of RESET\_N by Using Driving Circuit**



**Figure 15: Reference Circuit of RESET\_N by Using Button**

The reset scenario is illustrated in the following figure.



**Figure 16: Timing of Resetting Module**

#### NOTES

1. Use RESET\_N only when turning off the module by **AT+QPOWD** command and PWRKEY pin failed.
2. Ensure that there is no large capacitance on PWRKEY and RESET\_N pins.

### 3.9. USIM Card Interface

The USIM card interface circuitry meets ETSI and IMT-2000 SIM interface requirements. Both 1.8V and 3.0V USIM cards are supported.

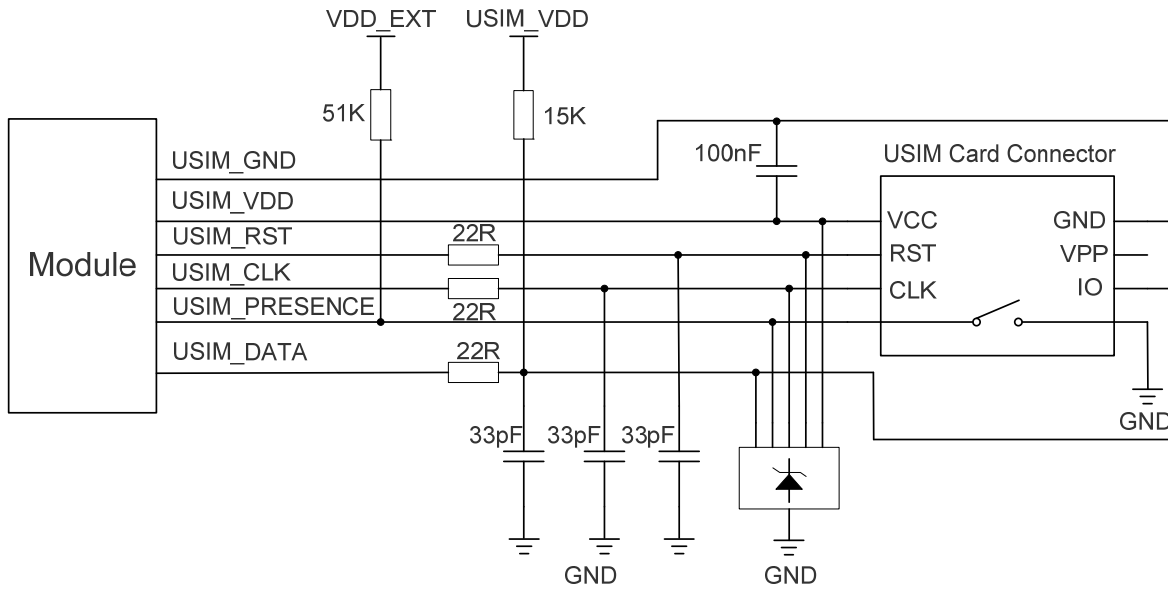
**Table 9: Pin Definition of the USIM Card Interface**

Pin Name	Pin No.	I/O	Description	Comment
USIM_VDD	14	PO	Power supply for USIM card	Either 1.8V or 3.0V is supported by the module automatically.
USIM_DATA	15	IO	Data signal of USIM card	
USIM_CLK	16	DO	Clock signal of USIM card	
USIM_RST	17	DO	Reset signal of USIM card	
USIM_PRESENCE	13	DI	USIM card insertion detection	
USIM_GND	10		Specified ground for USIM card	



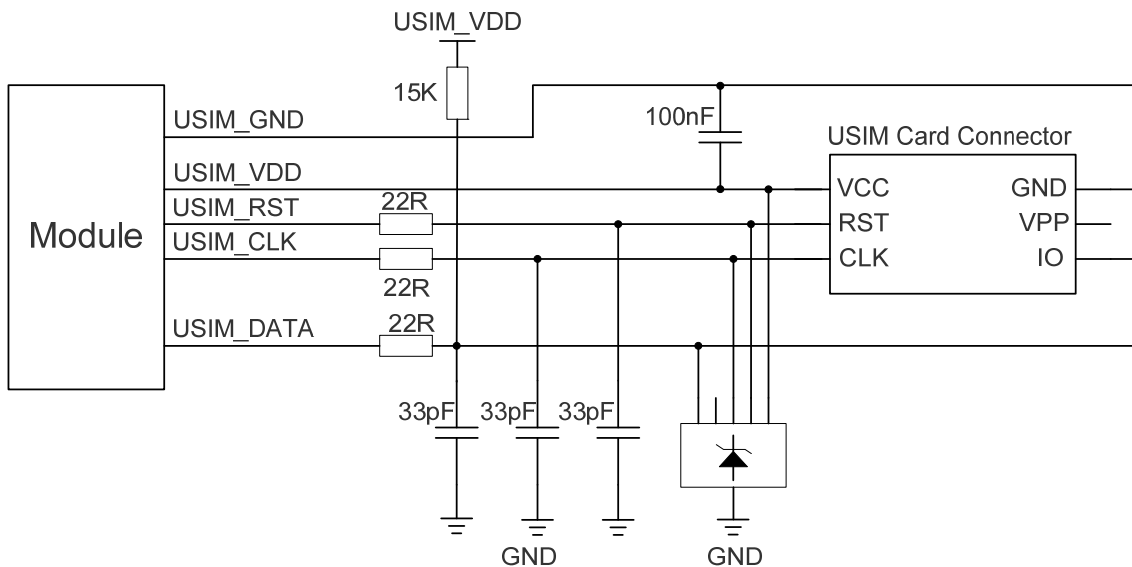
EC21 supports USIM card hot-plug via the USIM\_PRESENCE pin. The function supports low level and high level detections, and is disabled by default. Please refer to **document [2]** about **AT+QSIMDET** command for details.

The following figure shows a reference design for USIM card interface with an 8-pin USIM card connector.



**Figure 17: Reference Circuit of USIM Card Interface with an 8-Pin USIM Card Connector**

If USIM card detection function is not needed, please keep USIM\_PRESENCE unconnected. A reference circuit for USIM card interface with a 6-pin USIM card connector is illustrated in the following figure.



**Figure 18: Reference Circuit of USIM Card Interface with a 6-Pin USIM Card Connector**

In order to enhance the reliability and availability of the USIM card in your application, please follow the criteria below in USIM circuit design:

- Keep layout of USIM card as close to the module as possible. Keep the trace length as less than 200mm as possible.
- Keep USIM card signals away from RF and VBAT traces.
- Assure the ground between the module and the USIM card connector short and wide. Keep the trace width of ground and USIM\_VDD no less than 0.5mm to maintain the same electric potential.
- To avoid cross-talk between USIM\_DATA and USIM\_CLK, keep them away from each other and shield them with surrounded ground.
- In order to offer good ESD protection, it is recommended to add a TVS diode array whose parasitic capacitance should not be more than 50pF. The 22ohm resistors should be added in series between the module and the USIM card so as to suppress EMI spurious transmission and enhance ESD protection. The 33pF capacitors are used for filtering interference of GSM900. Please note that the USIM peripheral circuit should be close to the USIM card connector.
- The pull-up resistor on USIM\_DATA line can improve anti-jamming capability when long layout trace and sensitive occasion are applied, and should be placed close to the USIM card connector.

### 3.10. USB Interface

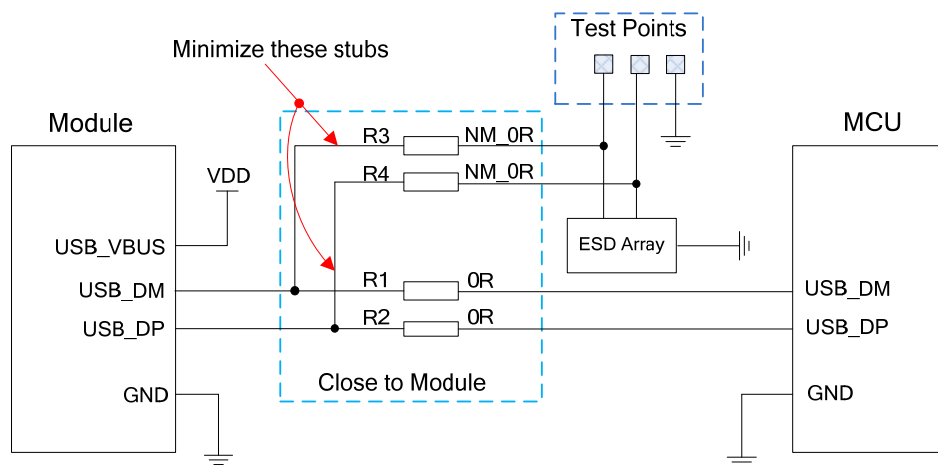
EC21 contains one integrated Universal Serial Bus (USB) transceiver which complies with the USB 2.0 specification and supports high-speed (480Mbps) and full-speed (12Mbps) modes. The USB interface is used for AT command communication, data transmission, GNSS NMEA sentences output, software debugging, firmware upgrade and voice over USB\*. The following table shows the pin definition of USB interface.

**Table 10: Pin Description of USB Interface**

Pin Name	Pin No.	I/O	Description	Comment
<b>USB Signal Part</b>				
USB_DP	69	IO	USB differential data bus (positive)	Require differential impedance of 90Ω
USB_DM	70	IO	USB differential data bus (minus)	Require differential impedance of 90Ω
USB_VBUS	71	PI	Used for detecting the USB connection	Typical 5.0V
GND	72		Ground	

For more details about the USB 2.0 specifications, please visit <http://www.usb.org/home>.

The USB interface is recommended to be reserved for firmware upgrade in your design. The following figure shows a reference circuit of USB interface.



**Figure 19: Reference Circuit of USB Application**

In order to ensure the integrity of USB data line signal, components R1, R2, R3 and R4 must be placed close to the module, and also these resistors should be placed close to each other. The extra stubs of trace must be as short as possible.

In order to ensure the USB interface design corresponding with the USB 2.0 specification, please comply with the following principles:

- It is important to route the USB signal traces as differential pairs with total grounding. The impedance of USB differential trace is 90ohm.
- Do not route signal traces under crystals, oscillators, magnetic devices or RF signal traces. It is important to route the USB differential traces in inner-layer with ground shielding on not only upper and lower layers but also right and left sides.
- Pay attention to the influence of junction capacitance of ESD protection components on USB data lines. Typically, the capacitance value should be less than 2pF.
- Keep the ESD protection components to the USB connector as close as possible.

#### NOTES

1. EC21 module can only be used as a slave device.
2. "\*" means under development.

### 3.11. UART Interfaces

The module provides two UART interfaces: the main UART interface and the debug UART interface. The following shows their features.

- The main UART interface supports 4800, 9600, 19200, 38400, 57600, 115200, 230400, 460800, 921600 and 3000000 bps baud rates, and the default is 115200 bps. The interface is used for data transmission and AT command communication.
- The debug UART interface supports 115200 bps baud rate. It is used for Linux console and log output.

The following tables show the pin definition of the main UART interface.

**Table 11: Pin Definition of the Main UART Interface**

Pin Name	Pin No.	I/O	Description	Comment
RI	62	DO	Ring indicator	
DCD	63	DO	Data carrier detection	
CTS	64	DO	Clear to send	
RTS	65	DI	Request to send	1.8V power domain
DTR	66	DI	Sleep mode control	
TXD	67	DO	Transmit data	
RXD	68	DI	Receive data	

**Table 12: Pin Definition of the Debug UART Interface**

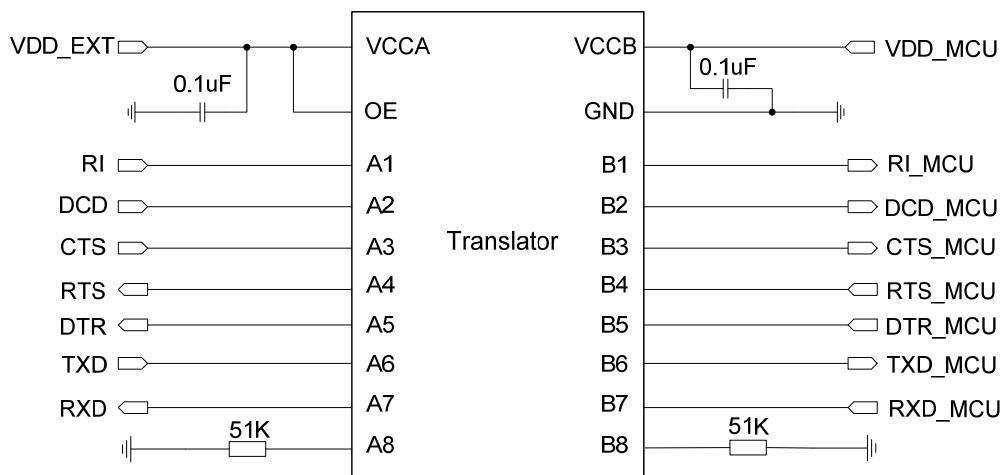
Pin Name	Pin No.	I/O	Description	Comment
DBG_TXD	12	DO	Transmit data	1.8V power domain
DBG_RXD	11	DI	Receive data	

The logic levels are described in the following table.

**Table 13: Logic Levels of Digital I/O**

Parameter	Min.	Max.	Unit
V <sub>IL</sub>	-0.3	0.6	V
V <sub>IH</sub>	1.2	2.0	V
V <sub>OL</sub>	0	0.45	V
V <sub>OH</sub>	1.35	1.8	V

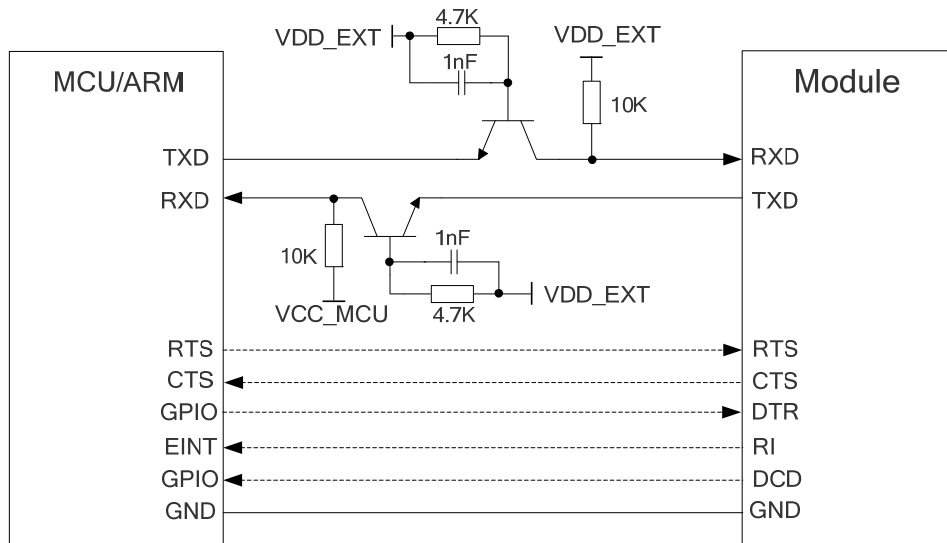
The module provides 1.8V UART interface. A level translator should be used if your application is equipped with a 3.3V UART interface. A level translator TXS0108EPWR provided by *Texas Instruments* is recommended. The following figure shows a reference design.



**Figure 20: Reference Circuit with Translator Chip**

Please visit <http://www.ti.com> for more information.

Another example with transistor translation circuit is shown as below. The circuit design of dotted line section can refer to the design of solid line section, in terms of both module input and output circuit designs; but please pay attention to the direction of connection.



**Figure 21: Reference Circuit with Transistor Circuit**

**NOTE**

Transistor circuit solution is not suitable for applications with high baud rates exceeding 460Kbps.

### 3.12. PCM and I2C Interfaces

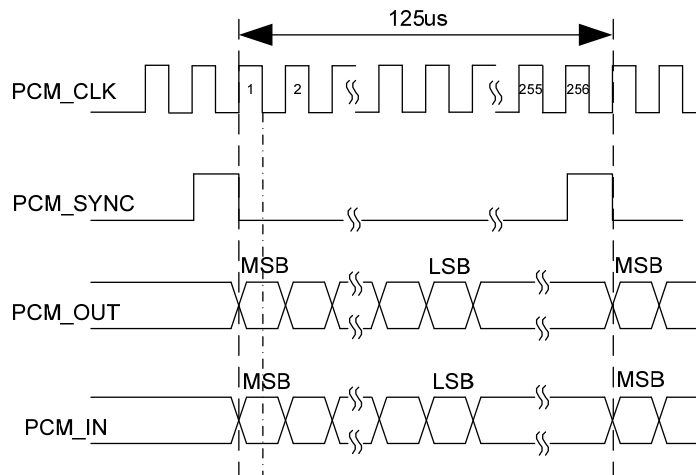
EC21 provides one Pulse Code Modulation (PCM) digital interface for audio design, which supports the following modes:

- Primary mode (short frame synchronization, works as both master and slave)
- Auxiliary mode (long framesynchronization, works as master only)

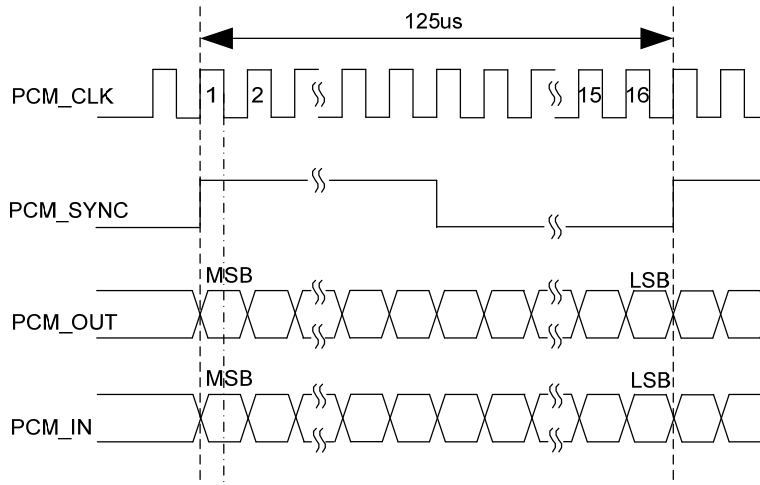
In primary mode, the data is sampled on the falling edge of the PCM\_CLK and transmitted on the rising edge. The PCM\_SYNC falling edge represents the MSB. In this mode, PCM\_CLK supports 128,256,512,1024 and2048kHz for different speech codecs.

In auxiliary mode, the data is also sampled on the falling edge of the PCM\_CLK and transmitted on the rising edge. But the PCM\_SYNC rising edge represents the MSB. In this mode, PCM interface operates with a 128kHz PCM\_CLK and an 8kHz, 50% duty cycle PCM\_SYNC only.

EC21 supports 8-bit A-law\* and  $\mu$ -law\*, and also 16-bit linear data formats. The following figures show the primary mode's timing relationship with 8kHz PCM\_SYNC and 2048kHz PCM\_CLK, as well as the auxiliary mode's timing relationship with 8kHz PCM\_SYNC and 128kHz PCM\_CLK.



**Figure 22: Primary Mode Timing**



**Figure 23: Auxiliary Mode Timing**

The following table shows the pin definition of PCM and I2C interfaces which can be applied on audio codec design.

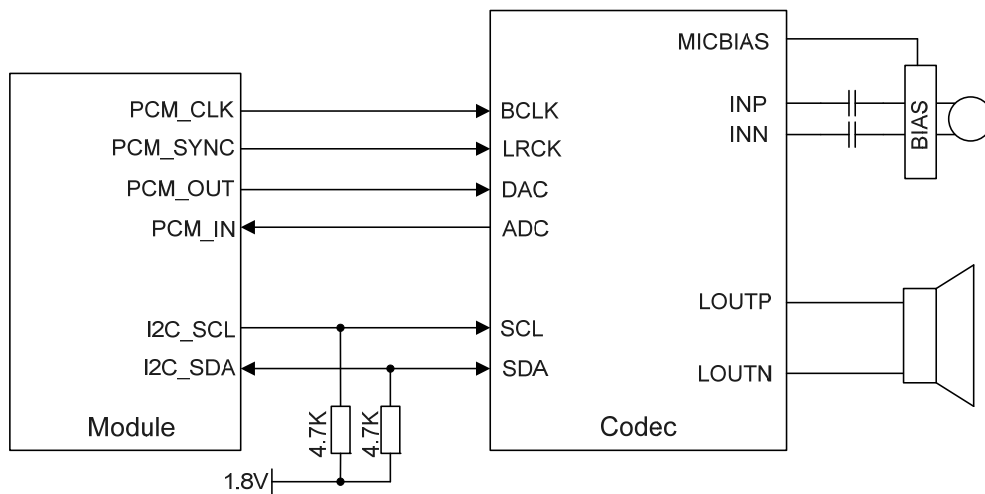
**Table 14: Pin Definition of PCM and I2C Interfaces**

Pin Name	Pin No.	I/O	Description	Comment
PCM_IN	24	DI	PCM data input	1.8V power domain
PCM_OUT	25	DO	PCM data output	1.8V power domain
PCM_SYNC	26	IO	PCM data frame sync signal	1.8V power domain

PCM_CLK	27	IO	PCM data bit clock	1.8V power domain
I2C_SCL	41	OD	I2C serial clock	Require external pull-up to 1.8V
I2C_SDA	42	OD	I2C serial data	Require external pull-up to 1.8V

Clock and mode can be configured by AT command, and the default configuration is master mode using short frame synchronization format with 2048kHz PCM\_CLK and 8kHz PCM\_SYNC. Please refer to **document [2]** about **AT+QDAI** command for details.

The following figure shows a reference design of PCM interface with external codec IC.



**Figure 24: Reference Circuit of PCM Application with Audio Codec**

**NOTES**

1. “\*” means under development.
2. It is recommended to reserve RC (R=22ohm, C=22pF) circuit on the PCM lines, especially for PCM\_CLK.
3. EC21 works as a master device pertaining to I2C interface.



### 3.13. ADC Function

The module provides two analog-to-digital converters (ADC). **AT+QADC=0** command can be used to read the voltage value on ADC0 pin. **AT+QADC=1** command can be used to read the voltage value on ADC1 pin. For more details about these AT commands, please refer to **document [2]**.

In order to improve the accuracy of ADC, the trace of ADC should be surrounded by ground.

**Table 15: Pin Definition of the ADC**

Pin Name	Pin No.	Description
ADC0	45	General purpose analog to digital converter
ADC1	44	General purpose analog to digital converter

The following table describes the characteristic of the ADC function.

**Table 16: Characteristic of the ADC**

Parameter	Min.	Typ.	Max.	Unit
ADC0 Voltage Range	0.3		VBAT_BB	V
ADC1 Voltage Range	0.3		VBAT_BB	V
ADC Resolution			15	bits

#### NOTES

1. ADC input voltage must not exceed VBAT\_BB.
2. It is prohibited to supply any voltage to ADC pins when VBAT is removed.
3. It is recommended to use resistor divider circuit for ADC application.

### 3.14. Network Status Indication

The network indication pins can be used to drive network status indication LEDs. The module provides two pins which are NET\_MODE and NET\_STATUS. The following tables describe the pin definition and logic level changes in different network status.

**Table 17: Pin Definition of Network Connection Status/Activity Indicator**

Pin Name	Pin No.	I/O	Description	Comment
NET_MODE <sup>1)</sup>	5	DO	Indicate the module's network registration status	1.8V power domain
NET_STATUS	6	DO	Indicate the module's network activity status	

**NOTE**

<sup>1)</sup> means that this pin cannot be pulled up before startup.

**Table 18: Working State of Network Connection Status/Activity Indicator**

Pin Name	Logic Level Changes	Network Status
NET_MODE	Always High	Registered on LTE network
	Always Low	Others
NET_STATUS	Flicker slowly (200ms High/1800ms Low)	Network searching
	Flicker slowly (1800ms High/200ms Low)	Idle
	Flicker quickly (125ms High/125ms Low)	Data transfer is ongoing
	Always High	Voice calling

A reference circuit is shown in the following figure.

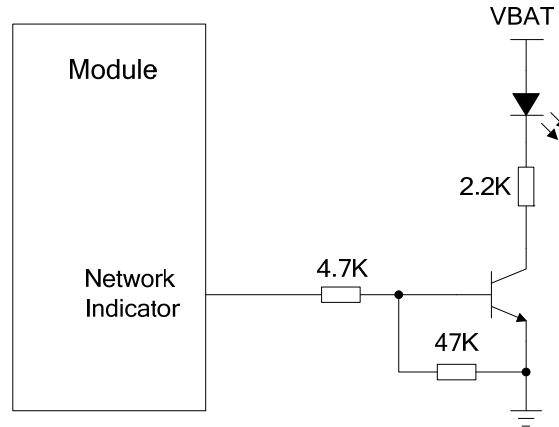


Figure 25: Reference Circuit of the Network Indicator

### 3.15. STATUS

The STATUS pin is an open drain output for indicating the module's operation status. You can connect it to a GPIO of DTE with a pull up resistor, or as the LED indication circuit shown below. When the module is turned on normally, the STATUS will present the low state. Otherwise, the STATUS will present high-impedance state.

Table 19: Pin Definition of STATUS

Pin Name	Pin No.	I/O	Description	Comment
STATUS	61	OD	Indicate the module's operation status	Require external pull-up

The following figure shows different circuit designs of STATUS, and you can choose either one according to your application demands.

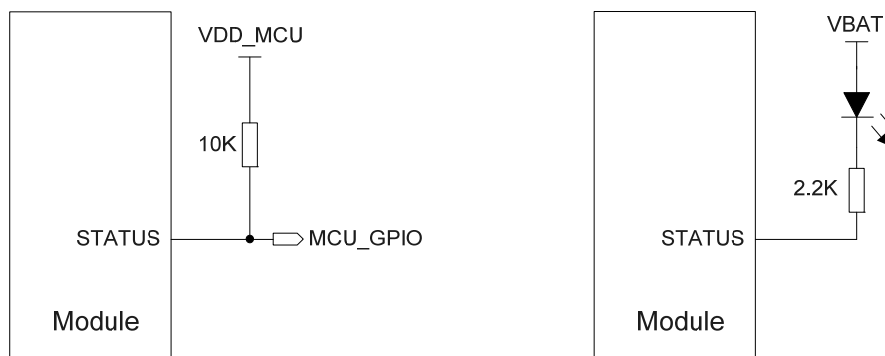


Figure 26: Reference Circuits of STATUS

### 3.16. Behavior of the RI

**AT+QCFG="risignalttype", "physical"** command can be used to configure RI behavior.

No matter on which port URC is presented, URC will trigger the behavior of RI pin.

**NOTE**

URC can be output from UART port, USB AT port and USB modem port by **AT+QURCCFG** command. The default port is USB AT port.

In addition, RI behavior can be configured flexibly. The default behavior of the RI is shown as below.

**Table 20: Behavior of the RI**

State	Response
Idle	RI keeps in high level
URC	RI outputs 120ms low pulse when new URC returns

The RI behavior can be changed by **AT+QCFG="urc/ri/ring"** command. Please refer to **document [2]** for details.

### 3.17. SGMII Interface

EC21 includes an integrated Ethernet MAC with an SGMII interface and two management interfaces, key features of the SGMII interface are shown below:

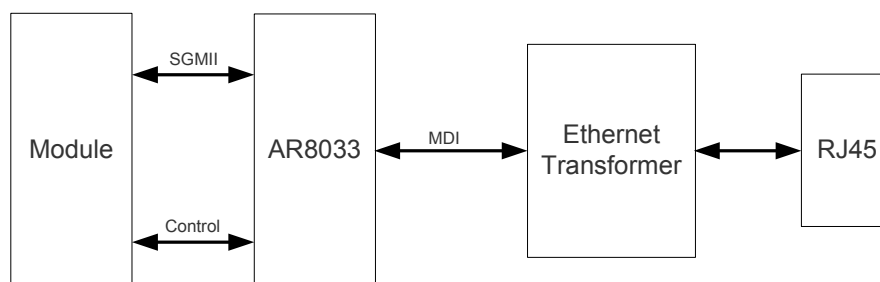
- IEEE802.3 compliance
- Full duplex at 1000Mbps
- Half/full duplex for 10/100Mbps
- Support VLAN tagging
- Support IEEE1588 and Precision Time Protocol (PTP)
- Can be used to connect to external Ethernet PHY like AR8033, or to an external switch
- Management interfaces support dual voltage 1.8V/2.85V

The following table shows the pin definition of SGMII interface.

**Table 21: Pin Definition of the SGMII Interface**

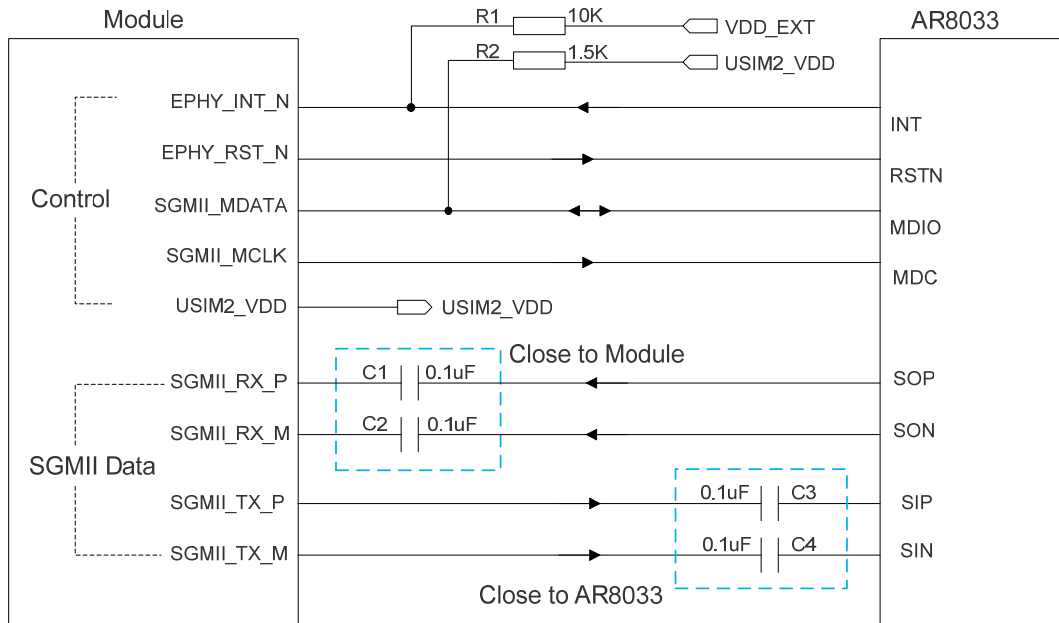
Pin Name	Pin No.	I/O	Description	Comment
<b>Control Signal Part</b>				
EPHY_RST_N	119	DO	Ethernet PHY reset	1.8V/2.85V power domain
EPHY_INT_N	120	DI	Ethernet PHY interrupt	1.8V power domain
SGMII_MDATA	121	IO	SGMII MDIO (Management Data Input/Output) data	1.8V/2.85V power domain
SGMII_MCLK	122	DO	SGMII MDIO (Management Data Input/Output) clock	1.8V/2.85V power domain
USIM2_VDD	128	PO	SGMII MDIO pull-up power source	Configurable power source. 1.8V/2.85V power domain. External pull-up power source for SGMII MDIO pins.
<b>SGMII Signal Part</b>				
SGMII_TX_M	123	AO	SGMII transmission-minus	Connect with a 0.1uF capacitor, close to the PHY side.
SGMII_TX_P	124	AO	SGMII transmission-plus	Connect with a 0.1uF capacitor, close to the PHY side.
SGMII_RX_P	125	AI	SGMII receiving-plus	Connect with a 0.1uF capacitor, close to EC21 module.
SGMII_RX_M	126	AI	SGMII receiving-minus	Connect with a 0.1uF capacitor, close to EC21 module.

The following figure shows the simplified block diagram for Ethernet application.



**Figure 27: Simplified Block Diagram for Ethernet Application**

The following figure shows a reference design of SGMII interface with PHY AR8033 application.



**Figure 28: Reference Circuit of SGMII Interface with PHY AR8033 Application**

In order to enhance the reliability and availability in your application, please follow the criteria below in the Ethernet PHY circuit design:

- Keep SGMII data and control signals away from RF and VBAT trace.
- Keep the maximum trace length less than 10inch and keep skew on the differential pairs less than 20mil.
- The differential impedance of SGMII data trace is 100ohm±10%.
- To minimize crosstalk, the distance between separate adjacent pairs that are on the same layer must be equal to or larger than 40mil.

**NOTE**

For more information about SGMII application, please refer to **document [5]** and **document [7]**.

### 3.18. Wireless Connectivity Interfaces

EC21 supports a low-power SDIO 3.0 interface for WLAN and a UART/PCM interface for BT.

The following table shows the pin definition of wireless connectivity interfaces.

**Table 22: Pin Definition of Wireless Connectivity Interfaces**

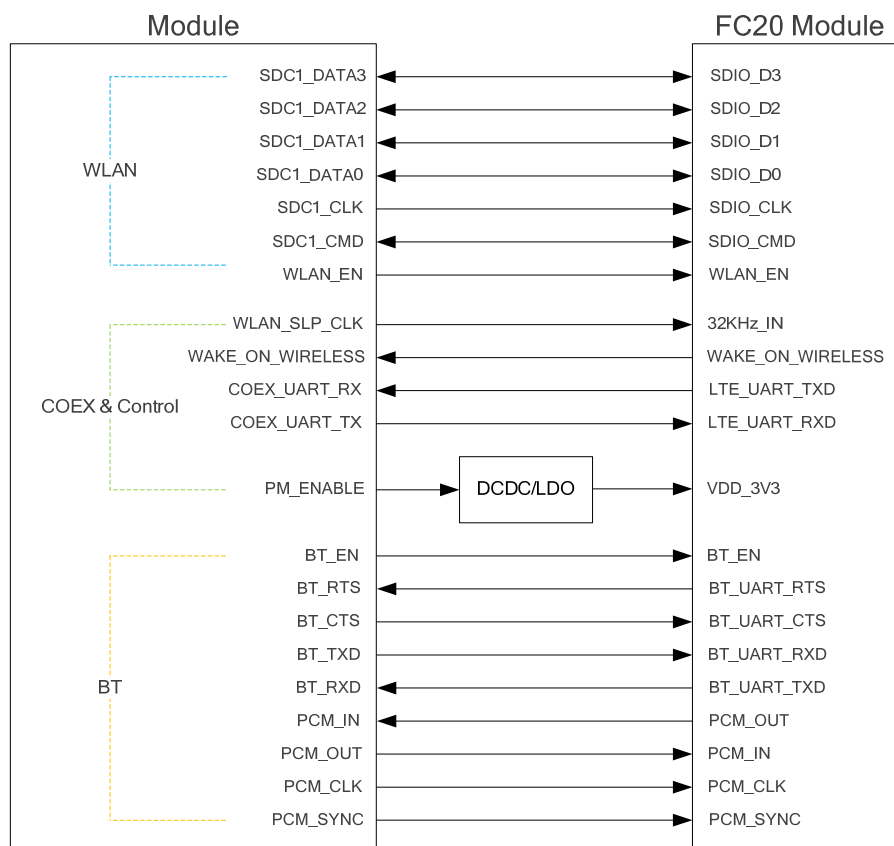
Pin Name	Pin No.	I/O	Description	Comment
<b>WLAN Part</b>				
SDC1_DATA3	129	IO	SDIO data bus D3	1.8V power domain
SDC1_DATA2	130	IO	SDIO data bus D2	1.8V power domain
SDC1_DATA1	131	IO	SDIO data bus D1	1.8V power domain
SDC1_DATA0	132	IO	SDIO data bus D0	1.8V power domain
SDC1_CLK	133	DO	SDIO clock	1.8V power domain
SDC1_CMD	134	IO	SDIO command	1.8V power domain
WLAN_EN	136	DO	WLAN function control via FC20 module. Active high.	1.8V power domain
<b>Coexistence and Control Part</b>				
PM_ENABLE	127	DO	External power control	1.8V power domain
WAKE_ON_WIRELESS	135	DI	Wake up the host (EC21 module) by FC20 module.	1.8V power domain
COEX_UART_RX	137	DI	LTE/WLAN&BT coexistence signal	1.8V power domain
COEX_UART_TX	138	DO	LTE/WLAN&BT coexistence signal	1.8V power domain
WLAN_SLP_CLK	118	DO	WLAN sleep clock	
<b>BT Part*</b>				
BT_RTS*	37	DI	BT UART request to send	1.8V power domain
BT_TXD*	38	DO	BT UART transmit data	1.8V power domain
BT_RXD*	39	DI	BT UART receive data	1.8V power domain

BT_CTS*	40	DO	BT UART clear to send	1.8V power domain
PCM_IN <sup>1)</sup>	24	DI	PCM data input	1.8V power domain
PCM_OUT <sup>1)</sup>	25	DO	PCM data output	1.8V power domain
PCM_SYNC <sup>1)</sup>	26	IO	PCM data frame sync signal	1.8V power domain
PCM_CLK <sup>1)</sup>	27	IO	PCM data bit clock	1.8V power domain
BT_EN*	139	DO	WLAN function control via FC20 module. Active high.	1.8V power domain

**NOTES**

1. "\*" means under development.
2. <sup>1)</sup> Pads 24~27 are multiplexing pins used for audio design on EC21 module and BT function on FC20 module.

The following figure shows a reference design of wireless connectivity interfaces with Quectel FC20 module.



**Figure 29: Reference Circuit of Wireless Connectivity Interfaces with FC20 Module**



## NOTES

1. FC20 module can only be used as a slave device,
2. When BT function is enabled on EC21 module, PCM\_SYNC and PCM\_CLK pins are only used to output signals.
3. For more information about wireless connectivity interfaces, please refer to **document [5]**.

### 3.18.1. WLAN Interface

EC21 provides a low power SDIO 3.0 interface and control interface for WLAN design.

SDIO interface supports the following modes:

- Single data rate (SDR) mode (up to 200MHz)
- Double data rate (DDR) mode (up to 52MHz)

As SDIO signals are very high-speed, in order to ensure the SDIO interface design corresponds with the SDIO 3.0 specification, please comply with the following principles:

- It is important to route the SDIO signal traces with total grounding. The impedance of SDIO signal trace is 50ohm ( $\pm 10\%$ ).
- Protect other sensitive signals/circuits (RF, analog signals, etc.) from SDIO corruption and protect SDIO signals from noisy signals (clocks, DCDCs, etc.).
- It is recommended to keep matching length between CLK and DATA/CMD less than 1mm and total routing length less than 50mm.
- Keep termination resistors within 15~24ohm on clock lines near the module and keep the route distance from the module clock pins to termination resistors less than 5mm.
- Make sure the adjacent trace spacing is 2x line width and bus capacitance is less than 15pF.

### 3.18.2. BT Interface\*

EC21 supports a dedicated UART interface and a PCM interface for BT function application.

Further information about BT interface will be added in future version of this document.

## NOTE

“\*” means under development.

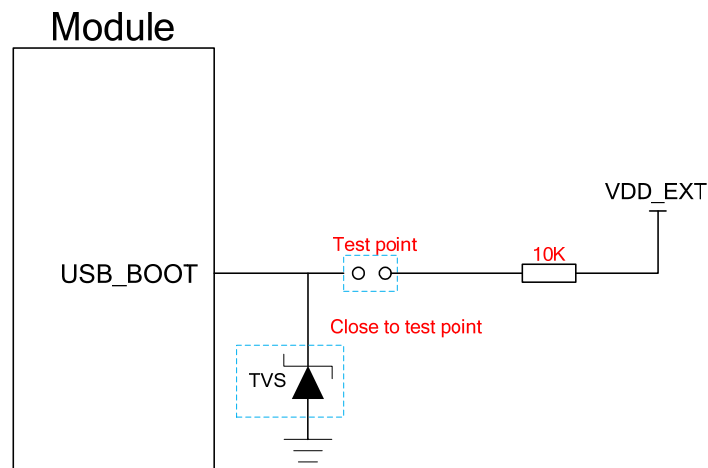
### 3.19. USB\_BOOT Interface

EC21 provides a USB\_BOOT pin. During development or factory production, USB\_BOOT pin can force the module to boot from USB port for firmware upgrade.

**Table 23: Pin Definition of USB\_BOOT Interface**

Pin Name	Pin No.	I/O	Description	Comment
USB_BOOT	115	DI	Force the module to boot from USB port	1.8V power domain. Active high. If unused, keep it open.

The following figure shows a reference circuit of USB\_BOOT interface.



**Figure 30: Reference Circuit of USB\_BOOT Interface**

# 4 GNSS Receiver

## 4.1. General Description

EC21 includes a fully integrated global navigation satellite system solution that supports Gen8C-Lite of Qualcomm (GPS, GLONASS, BeiDou, Galileo and QZSS).

EC21 supports standard NMEA-0183 protocol, and outputs NMEA sentences at 1Hz data update rate via USB interface by default.

By default, EC21 GNSS engine is switched off. It has to be switched on via AT command. For more details about GNSS engine technology and configurations, please refer to **document [3]**.

## 4.2. GNSS Performance

The following table shows the GNSS performance of EC21.

**Table 24: GNSS Performance**

Parameter	Description	Conditions	Typ.	Unit
Sensitivity (GNSS)	Cold start	Autonomous	-146	dBm
	Reacquisition	Autonomous	-157	dBm
	Tracking	Autonomous	-157	dBm
TTFF (GNSS)	Cold start	Autonomous	35	s
	@open sky	XTRA enabled	18	s
	Warm start	Autonomous	26	s
	@open sky	XTRA enabled	2.2	s

	Hot start @open sky	Autonomous	2.5	s
		XTRA enabled	1.8	s
Accuracy (GNSS)	CEP-50	Autonomous @open sky	<1.5	m

#### NOTES

1. Tracking sensitivity: the lowest GNSS signal value at the antenna port on which the module can keep on positioning for 3 minutes.
2. Reacquisition sensitivity: the lowest GNSS signal value at the antenna port on which the module can fix position again within 3 minutes after loss of lock.
3. Cold start sensitivity: the lowest GNSS signal value at the antenna port on which the module fixes position within 3 minutes after executing cold start command.

### 4.3. Layout Guidelines

The following layout guidelines should be taken into account in your design.

- Maximize the distance among GNSS antenna, main antenna and the Rx-diversity antenna.
- Digital circuits such as USIM card, USB interface, camera module, display connector and SD card should be kept away from the antennas.
- Use ground vias around the GNSS trace and sensitive analog signal traces to provide coplanar isolation and protection.
- Keep 50ohm characteristic impedance for the ANT\_GNSS trace.

Please refer to **Chapter 5** for GNSS antenna reference design and antenna consideration.

# 5 Antenna Interfaces

EC21 antenna interfaces include a main antenna interface, an Rx-diversity antenna interface which is used to resist the fall of signals caused by high speed movement and multipath effect, and a GNSS antenna interface. The antenna interfaces have an impedance of 50ohm.

## 5.1. Main/Rx-diversity Antenna Interface

### 5.1.1. Pin Definition

The pin definition of main antenna and Rx-diversity antenna interfaces is shown below.

**Table 25: Pin Definition of the RF Antenna**

Pin Name	Pin No.	I/O	Description	Comment
ANT_MAIN	49	IO	Main antenna pad	50ohm impedance
ANT_DIV	35	AI	Receive diversity antenna pad	50ohm impedance

### 5.1.2. Operating Frequency

**Table 26: Module Operating Frequencies**

3GPP Band	Transmit	Receive	Unit
B1	1920~1980	2110~2170	MHz
B2 (1900)	1850~1910	1930~1990	MHz
B3 (1800)	1710~1785	1805~1880	MHz
B4	1710~1755	2110~2155	MHz
B5 (850)	824~849	869~894	MHz
B7	2500~2570	2620~2690	MHz
B8 (900)	880~915	925~960	MHz

B12	699~716	729~746	MHz
B13	777~787	746~756	MHz
B18	815~830	860~875	MHz
B19	830~845	875~890	MHz
B20	832~862	791~821	MHz
B26	814~849	859~894	MHz
B28	703~748	758~803	MHz
B40	2300~2400	2300~2400	MHz

### 5.1.3. Reference Design of RF Antenna Interface

A reference design of ANT\_MAIN and ANT\_DIV antenna pads is shown as below. It should reserve a  $\pi$ -type matching circuit for better RF performance. The capacitors are not mounted by default.

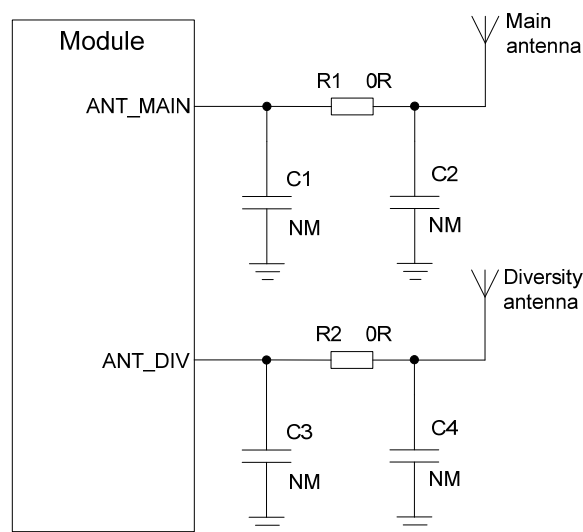


Figure 31: Reference Circuit of RF Antenna Interface

#### NOTES

1. Keep a proper distance between the main antenna and the Rx-diversity antenna to improve the receiving sensitivity.
2. ANT\_DIV function is enabled by default.
3. Place the  $\pi$ -type matching components (R1, C1, C2, R2, C3, C4) as close to the antenna as possible.

### 5.1.4. Reference Design of RF Layout

For user's PCB, the characteristic impedance of all RF traces should be controlled as 50 ohm. The impedance of the RF traces is usually determined by the trace width ( $W$ ), the materials' dielectric constant, the distance between signal layer and reference ground ( $H$ ), and the clearance between RF trace and ground ( $S$ ). Microstrip line or coplanar waveguide line is typically used in RF layout for characteristic impedance control. The following are reference designs of microstrip line or coplanar waveguide line with different PCB structures

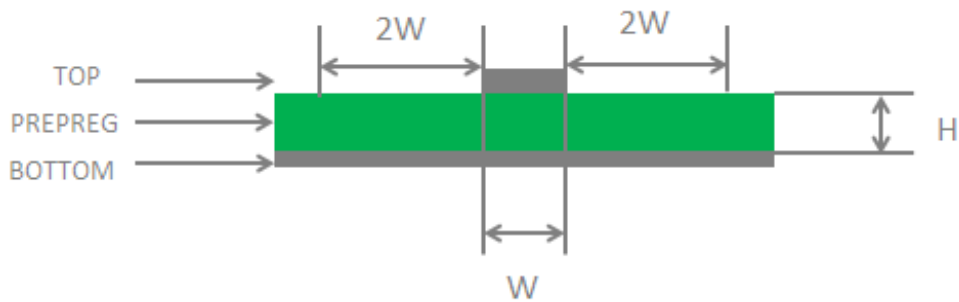


Figure 32: Microstrip Line Design on a 2-layer PCB

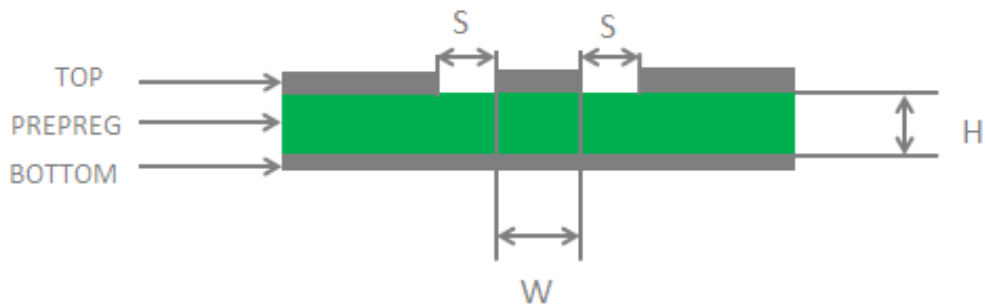
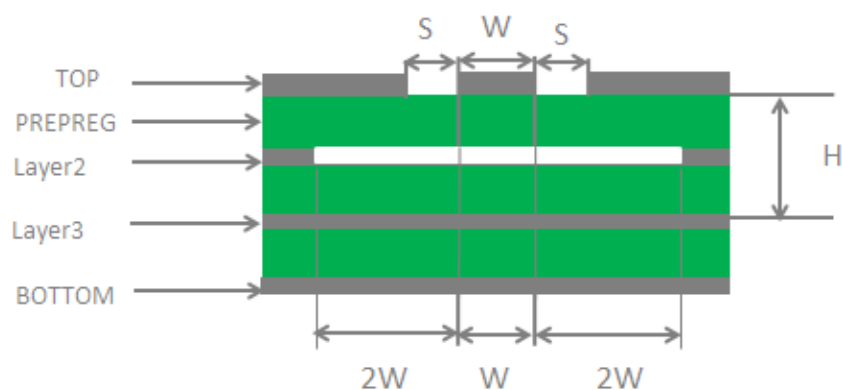
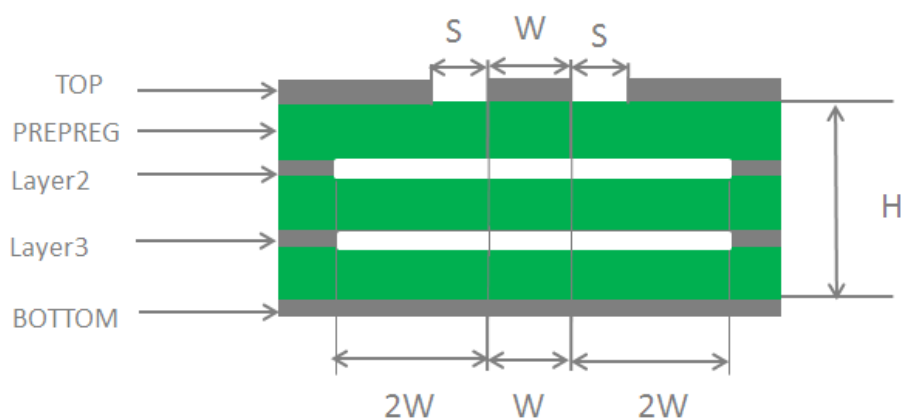


Figure 33: Coplanar Waveguide Line Design on a 2-layer PCB



**Figure 34: Coplanar Waveguide Line Design on a 4-layer PCB (Layer 3 as Reference Ground)**



**Figure 35: Coplanar Waveguide Line Design on a 4-layer PCB (Layer 4 as Reference Ground)**

In order to ensure RF performance and reliability, the following principles should be complied with in RF layout design:

- Use impedance simulation tool to control the characteristic impedance of RF traces as 50ohm.
- The GND pins adjacent to RF pins should not be hot welded, and should be fully connected to ground.
- The distance between the RF pins and the RF connector should be as short as possible, and all the right angle traces should be changed to curved ones.
- There should be clearance area under the signal pin of the antenna connector or solder joint.
- The reference ground of RF traces should be complete. Meanwhile, adding some ground vias around RF traces and the reference ground could help to improve RF performance. The distance between the ground vias and RF traces should be no less than two times the width of RF signal traces ( $2*W$ ).

For more details about RF layout, please refer to **document [6]**.



## 5.2. GNSS Antenna Interface

The following tables show the pin definition and frequency specification of GNSS antenna interface.

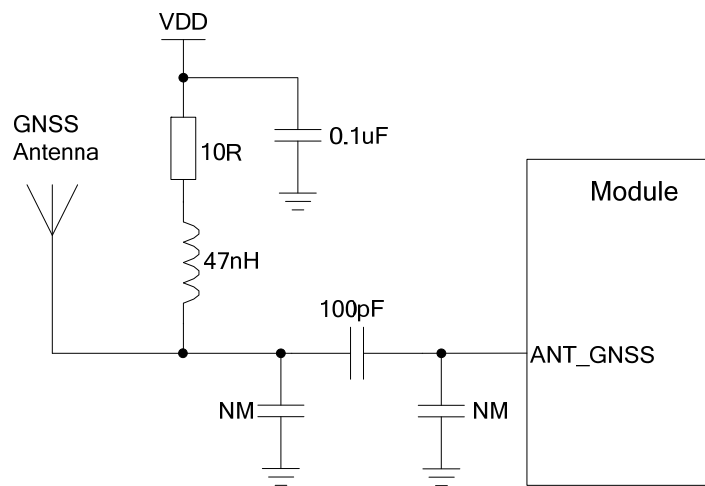
**Table 27: Pin Definition of GNSS Antenna Interface**

Pin Name	Pin No.	I/O	Description	Comment
ANT_GNSS	47	AI	GNSS antenna	50ohmimpedance

**Table 28: GNSS Frequency**

Type	Frequency	Unit
GPS/Galileo/QZSS	1575.42±1.023	MHz
GLONASS	1597.5~1605.8	MHz
BeiDou	1561.098±2.046	MHz

A reference design of GNSS antenna is shown as below.



**Figure 36: Reference Circuit of GNSS Antenna**

### NOTES

1. An external LDO can be selected to supply power according to the active antenna requirement.
2. If the module is designed with a passive antenna, then the VDD circuit is not needed.

## 5.3. Antenna Installation

### 5.3.1. Antenna Requirement

The following table shows the requirements on main antenna, Rx-diversity antenna and GNSS antenna.

**Table 29: Antenna Requirements**

Type	Requirements
GNSS	Frequency range: 1561~1615MHz Polarization: RHCP or linear VSWR: <2 (Typ.) Passive antenna gain: >0dBi Active antenna noise figure: <1.5dB Active antenna gain: >-2dBi Active antenna embedded LNA gain: 20dB (Typ.) Active antenna total gain: >18dBi (Typ.)
GSM/WCDMA/LTE	VSWR: ≤2 Gain (dBi): 1 Max input power (W): 50 Input Impedance (ohm): 50 Polarization type: Vertical Cable insertion loss: <1dB (GSM900, WCDMA B5/B8, LTE B5/B8/B12/B13/B18/B19/B20/B26/B28) Cable insertion loss: <1.5dB (GSM1800, WCDMA B1/B2/B4, LTE B1/B2/B3/B4) Cable insertion loss <2dB (LTE B7/B40)

### 5.3.2. Recommended RF Connector for Antenna Installation

If RF connector is used for antenna connection, it is recommended to use UF.L-R-SMT connector provided by HIROSE.

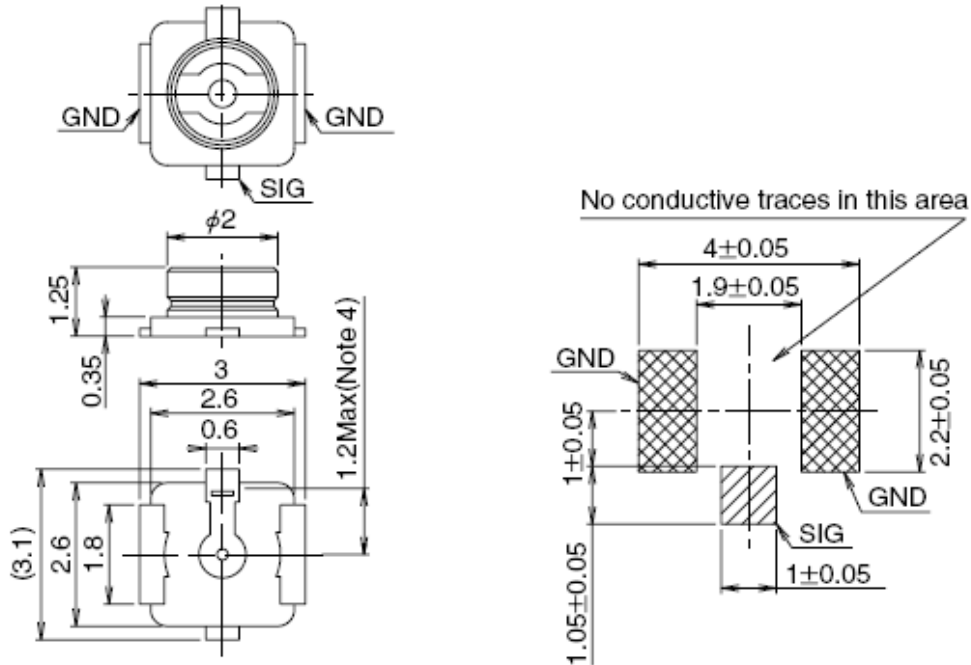


Figure 37: Dimensions of the UF.L-R-SMT Connector (Unit: mm)

U.FL-LP serial connectors listed in the following figure can be used to match the UF.L-R-SMT.

	U.FL-LP-040	U.FL-LP-066	U.FL-LP(V)-040	U.FL-LP-062	U.FL-LP-088
Part No.					
Mated Height	2.5mm Max. (2.4mm Nom.)	2.5mm Max. (2.4mm Nom.)	2.0mm Max. (1.9mm Nom.)	2.4mm Max. (2.3mm Nom.)	2.4mm Max. (2.3mm Nom.)
Applicable cable	Dia. 0.81mm Coaxial cable	Dia. 1.13mm and Dia. 1.32mm Coaxial cable	Dia. 0.81mm Coaxial cable	Dia. 1mm Coaxial cable	Dia. 1.37mm Coaxial cable
Weight (mg)	53.7	59.1	34.8	45.5	71.7
RoHS	YES				

Figure 38: Mechanicals of UF.L-LP Connectors

The following figure describes the space factor of mated connector.

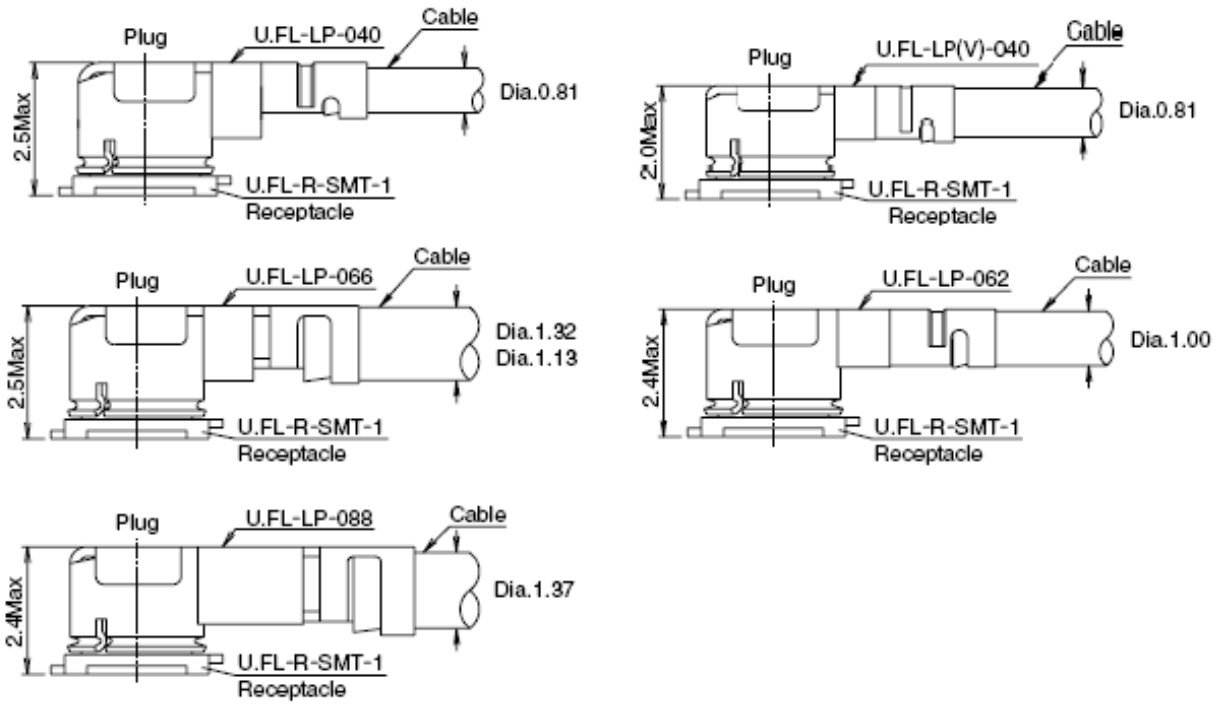


Figure39:Space Factor of Mated Connector (Unit: mm)

For more details, please visit <http://www.hirose.com>.

# 6 Electrical, Reliability and RadioCharacteristics

## 6.1. Absolute Maximum Ratings

Absolute maximum ratings for power supply and voltage on digital and analog pins of the module are listed in the following table.

**Table 30: Absolute Maximum Ratings**

Parameter	Min.	Max.	Unit
VBAT_RF/VBAT_BB	-0.3	4.7	V
USB_VBUS	-0.3	5.5	V
Peak Current of VBAT_BB	0	0.8	A
Peak Current of VBAT_RF	0	1.8	A
Voltage at Digital Pins	-0.3	2.3	V
Voltage at ADC0	0	VBAT_BB	V
Voltage at ADC1	0	VBAT_BB	V

## 6.2. Power Supply Ratings

**Table 31: Power Supply Ratings**

Parameter	Description	Conditions	Min.	Typ.	Max.	Unit
VBAT	VBAT_BB and	Voltage must stay within the	3.3	3.8	4.3	V

	VBAT_RF	min/max values, including voltage drop, ripple and spikes.				
	Voltage drop during burst transmission	Maximum power control level on GSM900		400	mV	
I <sub>VBAT</sub>	Peak supply current (during transmissionslot)	Maximum power control level on GSM900	1.8	2.0	A	
USB_VBUS	USB detection		3.0	5.0	5.25	V

### 6.3. Operating Temperature

The operating temperature is listed in the following table.

**Table 32: Operating Temperature**

Parameter	Min.	Typ.	Max.	Unit
OperationTemperature Range <sup>1)</sup>	-35	+25	+75	°C
ExtendedTemperature Range <sup>2)</sup>	-40		+85	°C

#### NOTES

- <sup>1)</sup> Within operation temperature range, the module is 3GPP compliant.
- <sup>2)</sup> Within extended temperature range, the module remains the ability to establish and maintain a voice, SMS, data transmission, emergency call, etc. There is no unrecoverable malfunction. There are also no effects on radio spectrum and no harm to radio network. Only one or more parameters like P<sub>out</sub> might reduce in their value and exceed the specified tolerances. When the temperature returns to the normal operating temperature levels, the module will meet 3GPP specifications again.

## 6.4. Current Consumption

The values of current consumption are shown below.

**Table 33: EC21-A Current Consumption**

Parameter	Description	Conditions	Typ.	Unit
$I_{VBAT}$	OFF state	Power down	20	uA
		<b>AT+CFUN=0</b> (USB disconnected)	1.0	mA
		WCDMA PF=64 (USB disconnected)	2.8	mA
	Sleep state	WCDMA PF=128 (USB disconnected)	2.3	mA
		LTE-FDD PF=64 (USB disconnected)	2.2	mA
		LTE-FDD PF=128 (USB disconnected)	2.2	mA
		WCDMA PF=64 (USB disconnected)	21.6	mA
	Idle state (GNSS OFF)	WCDMA PF=64 (USB connected)	31.6	mA
		LTE-FDDPF=64 (USB disconnected)	23.7	mA
		LTE-FDDPF=64 (USB connected)	36.5	mA
		WCDMA B2 HSDPA @22.09dBm	542.0	mA
		WCDMA B2 HSUPA @22.28dBm	681.0	mA
	WCDMA datatransfer(GNSS OFF)	WCDMA B4 HSDPA @21.94dBm	550.0	mA
		WCDMA B4 HSUPA @21.81dBm	547.0	mA
		WCDMA B5 HSDPA @22.13dBm	429.0	mA
		WCDMA B5 HSUPA @22.48dBm	459.0	mA
	LTE datatransfer(GNSS OFF)	LTE-FDD B2 @22.79dBm	709.0	mA
		LTE-FDD B4 @22.89dBm	710.0	mA
		LTE-FDD B12 @23.39dBm	679.0	mA
	WCDMA voice call	WCDMA B2 @23.67dBm	663.0	mA

WCDMA B4 @23.36dBm	594.0	mA
WCDMA B5 @23.64dBm	522.0	mA

**Table 34: EC21-AUT Current Consumption**

Parameter	Description	Conditions	Typ.	Unit	
I <sub>V</sub> BAT	OFF state	Power down	20	uA	
	Sleep state		<b>AT+CFUN=0</b> (USB disconnected)	0.99	mA
			WCDMA PF=64 (USB disconnected)	2.1	mA
			WCDMA PF=128 (USB disconnected)	1.7	mA
			LTE-FDD PF=64 (USB disconnected)	2.9	mA
			LTE-FDD PF=128 (USB disconnected)	2.4	mA
	Idle state		WCDMA PF=64 (USB disconnected)	22.0	mA
			WCDMA PF=64 (USB connected)	32.0	mA
			LTE-FDDPF=64 (USB disconnected)	23.6	mA
			LTE-FDDPF=64 (USB connected)	33.6	mA
	WCDMA data (GNSS OFF)	WCDMA B1 HSDPA@22.59dBm	WCDMA B1 HSDPA@22.59dBm	589.0	mA
			WCDMA B1 HSUPA@22.29dBm	623.0	mA
			WCDMA B5 HSDPA@22.22dBm	511.0	mA
			WCDMA B5 HSUPA@21.64dBm	503.0	mA
		LTE datatransfer(GNSS OFF)	LTE-FDD B1 @23.38dBm	813.0	mA
LTE-FDD B3 @22.87dBm			840.0	mA	
LTE-FDD B5 @23.12dBm			613.0	mA	
LTE-FDD B7 @22.96dBm			761.0	mA	
LTE-FDD B28 @23.31dBm			650.0	mA	
WCDMA voice call		WCDMA B1 @24.21dBm	687.0	mA	
	WCDMA B5 @23.18dBm	535.0	mA		



**Table 35: EC21-E Current Consumption**

Parameter	Description	Conditions	Typ.	Unit
I <sub>V</sub> BAT	OFF state	Power down	TBD	uA
		<b>AT+CFUN=0</b> (USB disconnected)	TBD	mA
		WCDMA PF=64 (USB disconnected)	TBD	mA
	Sleep state	WCDMA PF=128 (USB disconnected)	TBD	mA
		FDD-LTE PF=64 (USB disconnected)	TBD	mA
		FDD-LTE PF=128 (USB disconnected)	TBD	mA
	Idle state (GNSS OFF)	WCDMA PF=64 (USB disconnected)	TBD	mA
		WCDMA PF=64 (USB connected)	TBD	mA
		LTE-FDD PF=64 (USB disconnected)	TBD	mA
		LTE-FDD PF=64 (USB connected)	TBD	mA
	GPRS datatransfer(GNSS OFF)	GSM900 4DL/1UL @32.3dBm	220	mA
		GSM900 3DL/2UL @32.18dBm	387	mA
		GSM900 2DL/3UL @30.3dBm	467	mA
		GSM900 1DL/4UL @29.4dBm	555	mA
		DCS1800 4DL/1UL @29.6dBm	185	mA
		DCS1800 3DL/2UL @29.1dBm	305	mA
		DCS1800 2DL/3UL @28.8dBm	431	mA
		DCS1800 1DL/4UL @29.1dBm	540	mA
		GSM900 4DL/1UL @26dBm	148	mA
GSM900 3DL/2UL @26dBm		245	mA	
GSM900 2DL/3UL @25dBm		338	mA	
GSM900 1DL/4UL @25dBm		432	mA	
EDGE datatransfer(GNSS OFF)	DCS1800 4DL/1UL @26dBm	150	mA	
	DCS1800 3DL/2UL @25dBm	243	mA	
	DCS1800 2DL/3UL @25dBm	337	mA	

	DCS1800 1DL/4UL @25dBm	430	mA
WCDMA datatransfer(GNSS OFF)	WCDMA B1 HSDPA@22.5dBm	659	mA
	WCDMA B1 HSUPA@21.11dBm	545	mA
	WCDMA B5 HSDPA@23.5dBm	767	mA
	WCDMA B5 HSUPA@21.4dBm	537	mA
	WCDMA B8 HSDPA@22.41dBm	543	mA
	WCDMA B8 HSUPA@21.2dBm	445	mA
	LTE datatransfer(GNSS OFF)	LTE-FDD B1 @23.45dBm	807
LTE-FDD B3 @23.4dBm		825	mA
LTE-FDD B5 @23.4dBm		786	mA
LTE-FDD B7 @23.86dBm		887	mA
LTE-FDD B8 @23.5dBm		675	mA
LTE-FDD B20 @23.57dBm		770	mA
GSMvoice call	GSM900 PCL=5 @32.8dBm	336	mA
	PCS1800 PCL=0 @29.3dBm	291	mA
WCDMAvoice call	WCDMA B1 @23.69dBm	683	mA
	WCDMA B5 @23.61dBm	741	mA
	WCDMA B8 @23.35dBm	564	mA

**Table 36: EC21-KL Current Consumption**

Parameter	Description	Conditions	Typ.	Unit
I <sub>V</sub> BAT	OFF state	Power down	20	uA
		<b>AT+CFUN=0</b> (USB disconnected)	0.98	mA
	Sleep state	LTE-FDD PF=64 (USB disconnected)	2.5	mA
		LTE-FDD PF=128 (USB disconnected)	2.4	mA
	Idle state (GNSS OFF)	LTE-FDD PF=64 (USB disconnected)	23.0	mA
		LTE-FDD PF=64 (USB connected)	34.0	mA

LTE datatransfer(GNSS OFF)	LTE-FDD B1 @23.65dBm	765.0	mA
	LTE-FDD B3 @23.2dBm	825.0	mA
	LTE-FDD B5 @23.2dBm	598.0	mA
	LTE-FDD B7 @23.7dBm	762.0	mA
	LTE-FDD B8 @23.1dBm	569.0	mA

**Table 37: EC21-V Current Consumption**

Parameter	Description	Conditions	Typ.	Unit
I <sub>BAT</sub>	OFF state	Power down	20	uA
	Sleep state	<b>AT+CFUN=0</b> (USB disconnected)	1.0	mA
		LTE-FDD PF=64 (USB disconnected)	2.5	mA
	Idle state (GNSS OFF)	LTE-FDD PF=128 (USB disconnected)	2.0	mA
		LTE-FDD PF=64 (USB disconnected)	22.0	mA
		LTE-FDD PF=64 (USB connected)	32.0	mA
		LTE datatransfer(GNSS OFF)	LTE-FDD B4 @22.79dBm	752.0
		LTE-FDD B13 @23.26dBm	534.0	mA

**Table 38: EC21-AUV Current Consumption**

Parameter	Description	Conditions	Typ.	Unit
I <sub>BAT</sub>	OFF state	Power down	20	uA
	Sleep state	<b>AT+CFUN=0</b> (USB disconnected)	1.0	mA
		WCDMA PF=64 (USB disconnected)	2.0	mA
		WCDMA PF=128 (USB disconnected)	1.6	mA
	Idle state (GNSS OFF)	LTE-FDD PF=64 (USB disconnected)	2.4	mA
		LTE-FDD PF=128 (USB disconnected)	1.9	mA
		WCDMA PF=64 (USB disconnected)	24.0	mA
		WCDMA PF=64 (USB connected)	34.0	mA

	LTE-FDD PF=64 (USB disconnected)	24.0	mA
	LTE-FDD PF=64 (USB connected)	34.0	mA
WCDMA datatransfer(GNSS OFF)	WCDMA B1 HSDPA@22.05dBm	586.0	mA
	WCDMA B1 HSUPA@22.29dBm	630.0	mA
	WCDMA B5 HSDPA@22.43dBm	576.0	mA
	WCDMA B5 HSUPA@22.43dBm	600.0	mA
	WCDMA B8 HSDPA@22.44dBm	577.0	mA
	WCDMA B8 HSUPA@21.78dBm	555.0	mA
LTE datatransfer(GNSS OFF)	LTE-FDD B1 @23.12dBm	721.0	mA
	LTE-FDD B3 @23.04dBm	734.0	mA
	LTE-FDD B5 @23.16dBm	669.0	mA
	LTE-FDD B8 @23.21dBm	698.0	mA
	LTE-FDD B28 @23.57dBm	790.0	mA
WCDMA voice call	WCDMA B1 @22.72dBm	640.0	mA
	WCDMA B5 @23.19dBm	638.0	mA
	WCDMA B8 @23.27dBm	626.0	mA

**Table 39: GNSS Current Consumption of EC21 Series Module**

Parameter	Description	Conditions	Typ.	Unit
I <sub>VBAT</sub> (GNSS)	Searching (AT+CFUN=0)	Cold start @Passive Antenna	58	mA
		Lost state @Passive Antenna	58	mA
	Tracking (AT+CFUN=0)	Instrument Environment	33	mA
		OpenSky @Passive Antenna	35	mA
		OpenSky @Active Antenna	43	mA

## 6.5. RF Output Power

The following table shows the RF output power of EC21 module.

**Table 40: RF Output Power**

Frequency	Max.	Min.
GSM900	33dBm±2dB	5dBm±5dB
DCS1800	30dBm±2dB	0dBm±5dB
DCS1800	26dBm±3dB	0dBm±5dB
WCDMA bands	22.5dBm+1/-3dB	<-50dBm
LTE-FDD bands	22.5dBm+1/-3dB	<-44dBm
LTE-TDD bands	22.5dBm+1/-3dB	<-44dBm

### NOTE

In GPRS 4 slots TX mode, the maximum output power is reduced by 3.0dB. The design conforms to the GSM specification as described in **Chapter 13.16** of 3GPP TS 51.010-1.

## 6.6. RF Receiving Sensitivity

The following tables show the conducted RF receiving sensitivity of EC21 series module.

**Table 41: EC21-E Conducted RF Receiving Sensitivity**

Frequency	Primary	Diversity	SIMO <sup>1)</sup>	3GPP (SIMO)
GSM900	-109.0dBm	/	/	-102.0dBm
DCS1800	-109.0dBm	/	/	-102.0dbm
WCDMA Band1	-110.5dBm	/	/	-106.7dBm
WCDMA Band5	-110.5dBm	/	/	-104.7dBm
WCDMA Band8	-110.5dBm	/	/	-103.7dBm

LTE-FDD B1(10M)	-98.0dBm	-98.0dBm	-101.5dBm	-96.3dBm
LTE-FDD B3(10M)	-96.5dBm	-98.5dBm	-101.5dBm	-93.3dBm
LTE-FDD B5(10M)	-98.0dBm	-98.5dBm	-101.0dBm	-94.3dBm
LTE-FDD B7(10M)	-97.0dBm	-94.5dBm	-99.5dBm	-94.3dBm
LTE-FDD B8(10M)	-97.0dBm	-97.0dBm	-101.0dBm	-93.3dBm
LTE-FDD B20(10M)	-97.5dBm	-99.0dBm	-102.5dBm	-93.3dBm

**Table 42: EC21-A Conducted RF Receiving Sensitivity**

Frequency	Primary	Diversity	SIMO	3GPP (SIMO)
WCDMA B2	-110.0dBm	/	/	-104.7dBm
WCDMA B4	-110.0dBm	/	/	-106.7dBm
WCDMA B5	-110.5dBm	/	/	-104.7dBm
LTE-FDD B2 (10M)	-98.0dBm	-98.0dBm	-101.0dBm	-94.3dBm
LTE-FDD B4 (10M)	-97.5dBm	-99.0dBm	-101.0dBm	-96.3dBm
LTE-FDD B12 (10M)	-96.5dBm	-98.0dBm	-101.0dBm	-93.3dBm

**Table 43: EC21-V Conducted RF Receiving Sensitivity**

Frequency	Primary	Diversity	SIMO	3GPP (SIMO)
LTE-FDD B4 (10M)	-97.5dBm	-99.0dBm	-101.0dBm	-96.3dBm
LTE-FDD B13 (10M)	-95.0dBm	-97.0dBm	-100.0dBm	-93.3dBm

**Table 44: EC21-AUT Conducted RF Receiving Sensitivity**

Frequency	Primary	Diversity	SIMO	3GPP (SIMO)
WCDMA B1	-110.0dBm	/	/	-106.7dBm
WCDMA B5	-110.5dBm	/	/	-104.7dBm

LTE-FDD B1(10M)	-98.5dBm	-98.0dBm	-101.0dBm	-96.3dBm
LTE-FDD B3(10M)	-98.0dBm	-96.0dBm	-100.0dBm	-93.3dBm
LTE-FDD B5(10M)	-98.0dBm	-99.0dBm	-102.5dBm	-94.3dBm
LTE-FDD B7(10M)	-97.0dBm	-95.0dBm	-98.5dBm	-94.3dBm
LTE-FDD B28(10M)	-97.0dBm	-99.0dBm	-102.0dBm	-94.8dBm

**Table 45: EC21-AUTL Conducted RF Receiving Sensitivity**

Frequency	Primary	Diversity	SIMO	3GPP (SIMO)
LTE-FDD B3(10M)	-98.0dBm	-96.0dBm	-100.0dBm	-93.3dBm
LTE-FDD B7(10M)	-97.0dBm	-95.0dBm	-98.5dBm	-94.3dBm
LTE-FDD B28(10M)	-97.0dBm	-99.0dBm	-102.0dBm	-94.8dBm

**Table 46: EC21-KL Conducted RF Receiving Sensitivity**

Frequency	Primary	Diversity	SIMO	3GPP (SIMO)
LTE-FDD B1(10M)	-98.0dBm	-99.5dBm	-100.5dBm	-96.3dBm
LTE-FDD B3(10M)	-97.0dBm	-97.5dBm	-99.5dBm	-93.3dBm
LTE-FDD B5(10M)	-98.0dBm	-99.5dBm	-100.5dBm	-94.3dBm
LTE-FDD B7(10M)	-96.0dBm	-96.0dBm	-98.5dBm	-94.3dBm
LTE-FDD B8(10M)	-97.0dBm	-99.0dBm	-101.0dBm	-93.3dBm

**Table 47: EC21-CT Conducted RF Receiving Sensitivity**

Frequency	Primary	Diversity	SIMO	3GPP (SIMO)
LTE-FDD B1(10M)	-98.0dBm	-99.5dBm	-100.5dBm	-96.3dBm
LTE-FDD B3(10M)	-97.0dBm	-97.5dBm	-99.5dBm	-93.3dBm
LTE-FDD B5* (10M)	TBD	TBD	TBD	TBD

**Table 48: EC21-J Conducted RF Receiving Sensitivity**

Frequency	Primary	Diversity	SIMO	3GPP (SIMO)
LTE-FDD B1 (10M)	-97.5dBm	-98.7dBm	-100.2dBm	-96.3dBm
LTE-FDD B3 (10M)	-96.5dBm	-97.1dBm	-100.5dBm	-93.3dBm
LTE-FDD B8 (10M)	-98.4dBm	-99.0dBm	-101.2dBm	-93.3dBm
LTE-FDD B18 (10M)	-99.5dBm	-99.0dBm	-101.7dBm	-96.3dBm
LTE-FDD B19 (10M)	-99.2dBm	-99.0dBm	-101.4dBm	-96.3dBm
LTE-FDD B26 (10M)	-99.5dBm	-99.0dBm	-101.5dBm	-93.8dBm

**Table 49: EC21-AUV Conducted RF Receiving Sensitivity**

Frequency	Primary	Diversity	SIMO	3GPP (SIMO)
WCDMA B1	-110.0dBm	/	/	-106.7dBm
WCDMA B5	-111.0dBm	/	/	-104.7dBm
WCDMA B8	-111.0dBm	/	/	-103.7dBm
LTE-FDD B1 (10M)	-97.2dBm	-97.2dBm	-100.2dBm	-96.3dBm
LTE-FDD B3 (10M)	-98.2dBm	-98.7dBm	-100.7dBm	-93.3dBm
LTE-FDD B5 (10M)	-99.2dBm	-98.7dBm	-101.7dBm	-94.3dBm
LTE-FDD B8 (10M)	-97.7dBm	-97.2dBm	-101.2dBm	-93.3dBm
LTE-FDD B28 (10M)	-97.0dBm	-98.2dBm	-101.2dBm	-94.8dBm

**NOTES**

- <sup>1)</sup> SIMO is a smart antenna technology that uses a single antenna at the transmitter side and two antennas at the receiver side, which can improve RX performance.
- “\*” means under development.



## 6.7. Electrostatic Discharge

The module is not protected against electrostatic discharge (ESD) in general. Consequently, it is subject to ESD handling precautions that typically apply to ESD sensitive components. Proper ESD handling and packaging procedures must be applied throughout the processing, handling and operation of any application that incorporates the module.

The following table shows the module's electrostatic discharge characteristics.

**Table 50: Electrostatic Discharge Characteristics**

Tested Points	Contact Discharge	Air Discharge	Unit
VBAT, GND	±5	±10	kV
All Antenna Interfaces	±4	±8	kV
Other Interfaces	±0.5	±1	kV

# 7 Mechanical Dimensions

This chapter describes the mechanical dimensions of the module. All dimensions are measured in mm.

## 7.1. Mechanical Dimensions of the Module

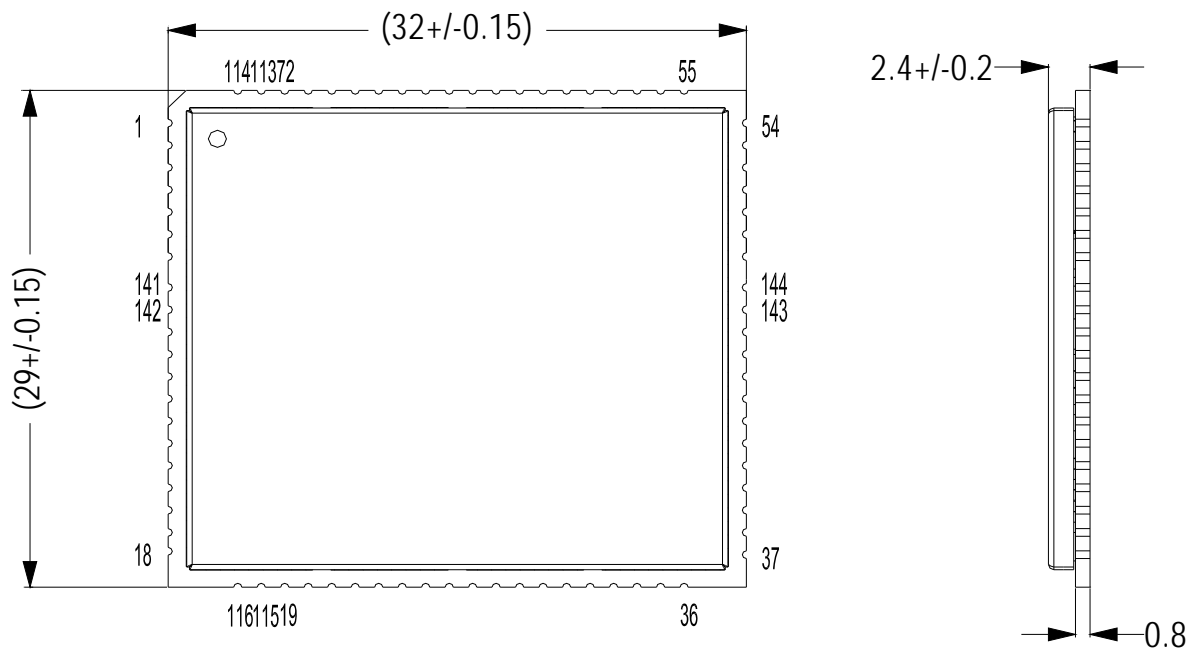


Figure40: Module Top and Side Dimensions

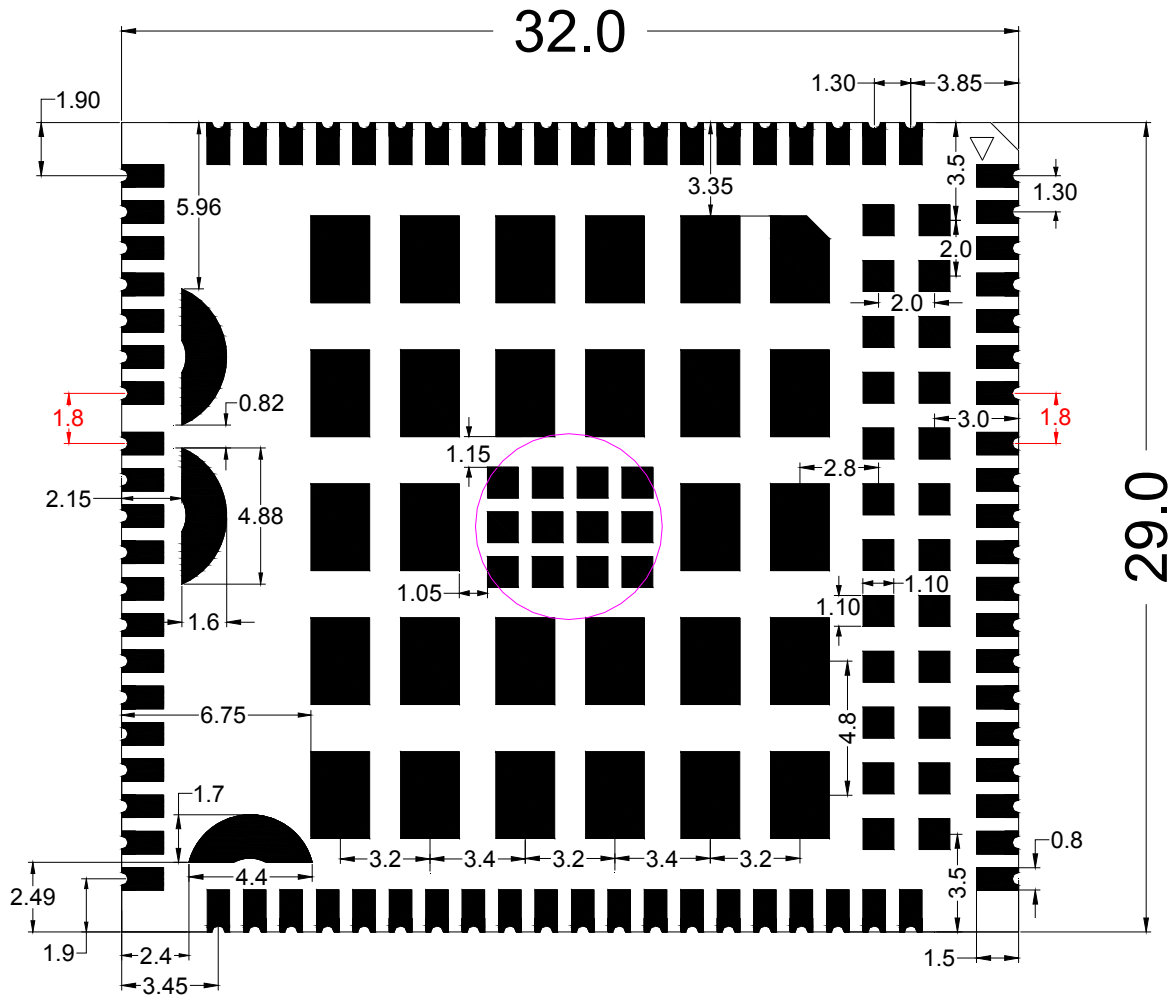


Figure41: Module Bottom Dimensions (Bottom View)

## 7.2. Recommended Footprint

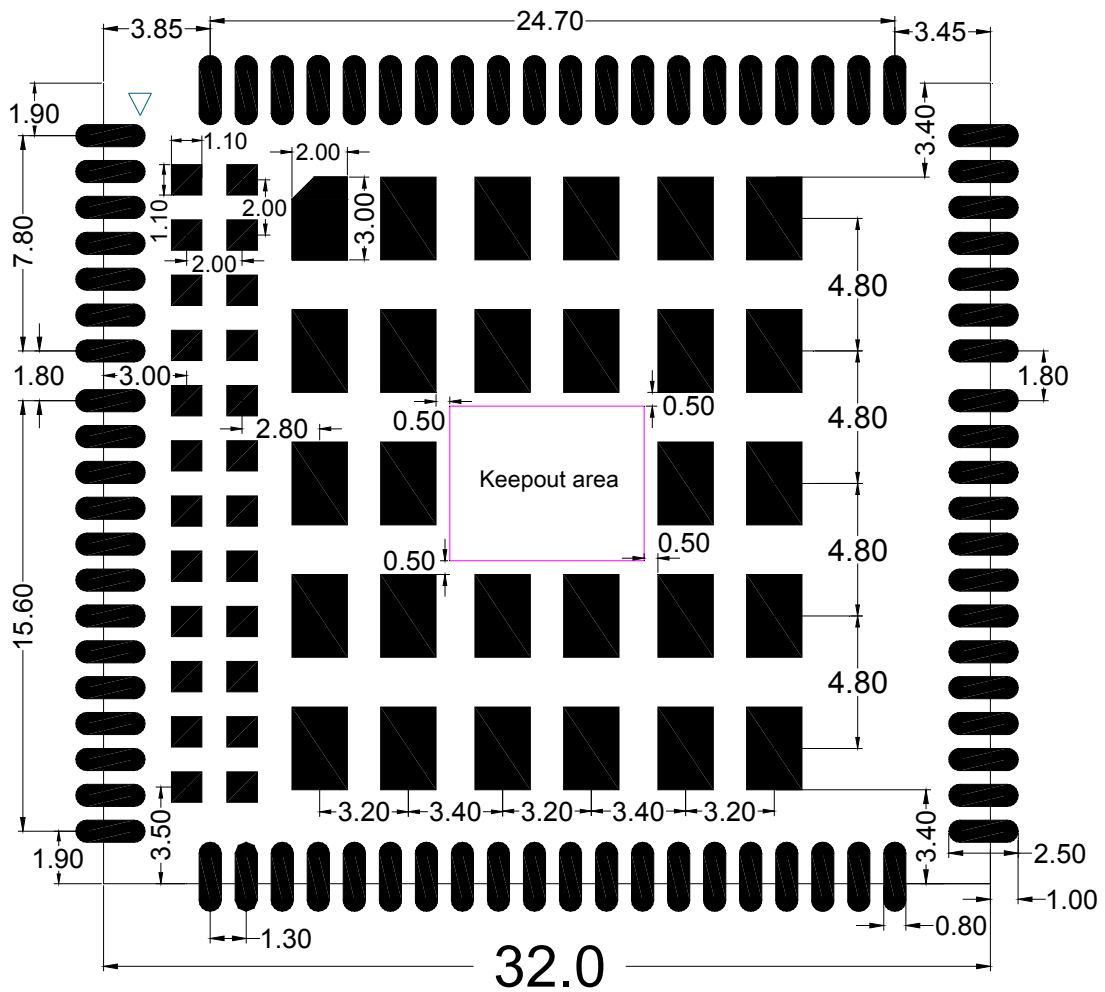


Figure42: Recommended Footprint (Top View)

### NOTES

1. The keepout area should not be designed.
2. For easy maintenance of the module, please keep about 3mm between the module and other components in the host PCB.

### 7.3. Design Effect Drawings of the Module



Figure43: Top View of the Module

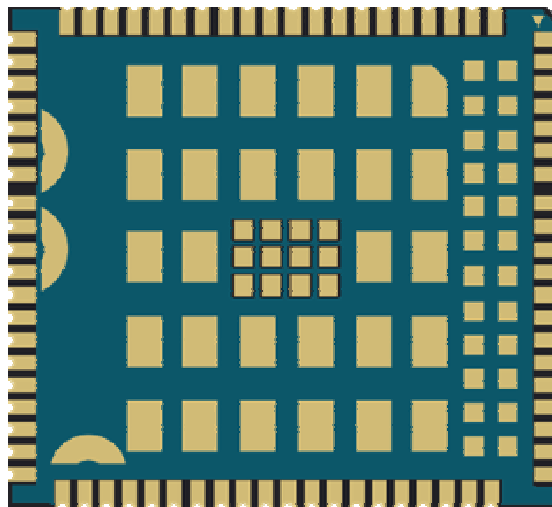


Figure 44: Bottom View of the Module

**NOTE**

These are design effect drawings of EC21 module. For more accurate pictures, please refer to the module that you get from Quectel.

# 8 Storage, Manufacturing and Packaging

## 8.1. Storage

EC21 is stored in a vacuum-sealed bag. The storage restrictions are shown as below.

1. Shelf life in the vacuum-sealed bag: 12 months at <math><40^{\circ}\text{C}/90\%RH</math>.
2. After the vacuum-sealed bag is opened, devices that will be subjected to reflow soldering or other high temperature processes must be:
  - Mounted within 72 hours at the factory environment of  $\leq 30^{\circ}\text{C}/60\%RH$
  - Stored at  $<10\%RH$
3. Devices require baking before mounting, if any circumstances below occurs:
  - When the ambient temperature is  $23^{\circ}\text{C}\pm 5^{\circ}\text{C}$  and the humidity indicator card shows the humidity is  $>10\%$  before opening the vacuum-sealed bag.
  - Device mounting cannot be finished within 72 hours at factory conditions of  $\leq 30^{\circ}\text{C}/60\%RH$ .
4. If baking is required, devices may be baked for 48 hours at  $125^{\circ}\text{C}\pm 5^{\circ}\text{C}$ .

### NOTE

As the plastic package cannot be subjected to high temperature, it should be removed from devices before high temperature ( $125^{\circ}\text{C}$ ) baking. If shorter baking time is desired, please refer to *IPC/JEDECJ-STD-033* for baking procedure.

## 8.2. Manufacturing and Soldering

Push the squeegee to apply the solder paste on the surface of stencil, thus making the paste fill the stencil openings and then penetrate to the PCB. The force on the squeegee should be adjusted properly so as to produce a clean stencil surface on a single pass. To ensure the module soldering quality, the thickness of stencil for the module is recommended to be 0.18mm. For more details, please refer to *document [4]*.

It is suggested that the peak reflow temperature is from 235 to 245°C (for SnAg3.0Cu0.5 alloy). The absolute maximum reflow temperature is 260°C. To avoid damage to the module caused by repeated heating, it is suggested that the module should be mounted after reflow soldering for the other side of PCB has been completed. Recommended reflow soldering thermal profile is shown below:

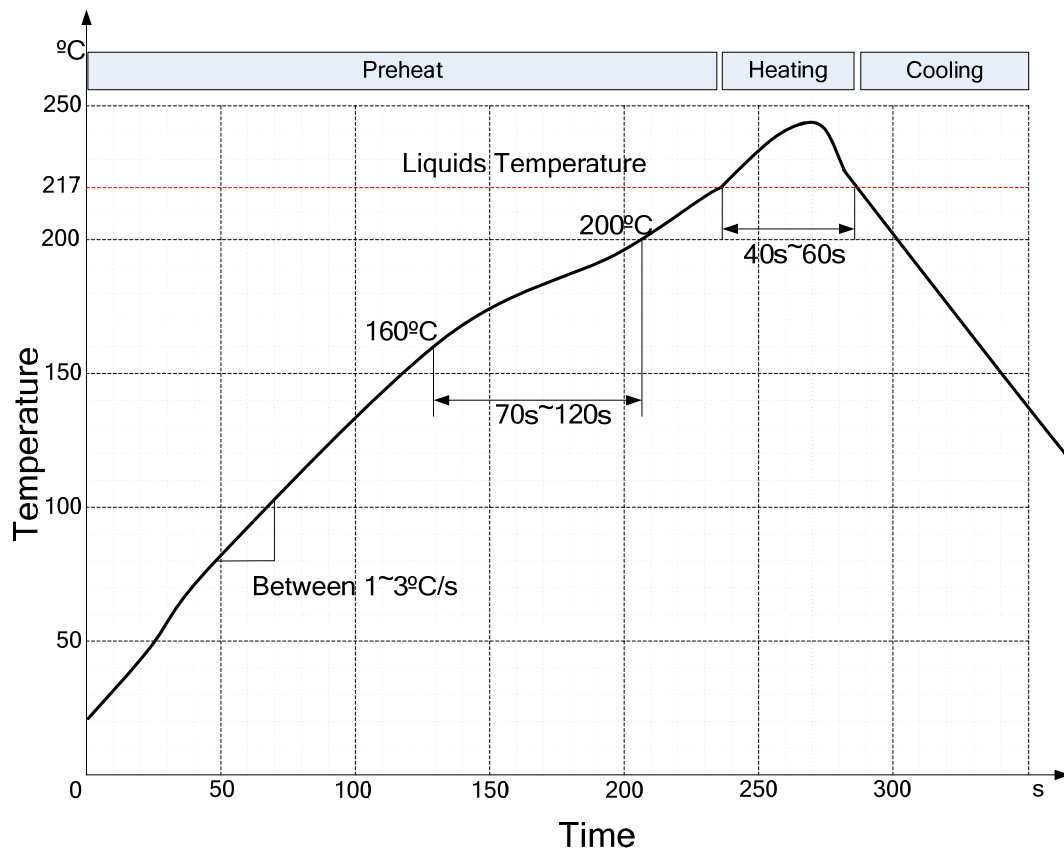


Figure 45: Reflow Soldering Thermal Profile

**NOTE**

During manufacturing and soldering, or any other processes that may contact the module directly, NEVER wipe the module label with organic solvents, such as acetone, ethyl alcohol, isopropyl alcohol, trichloroethylene, etc.

### 8.3. Packaging

EC21 is packaged in tape and reel carriers. One reel is 11.53m long and contains 250pcs modules. The figure below shows the packaging details, measured in mm.

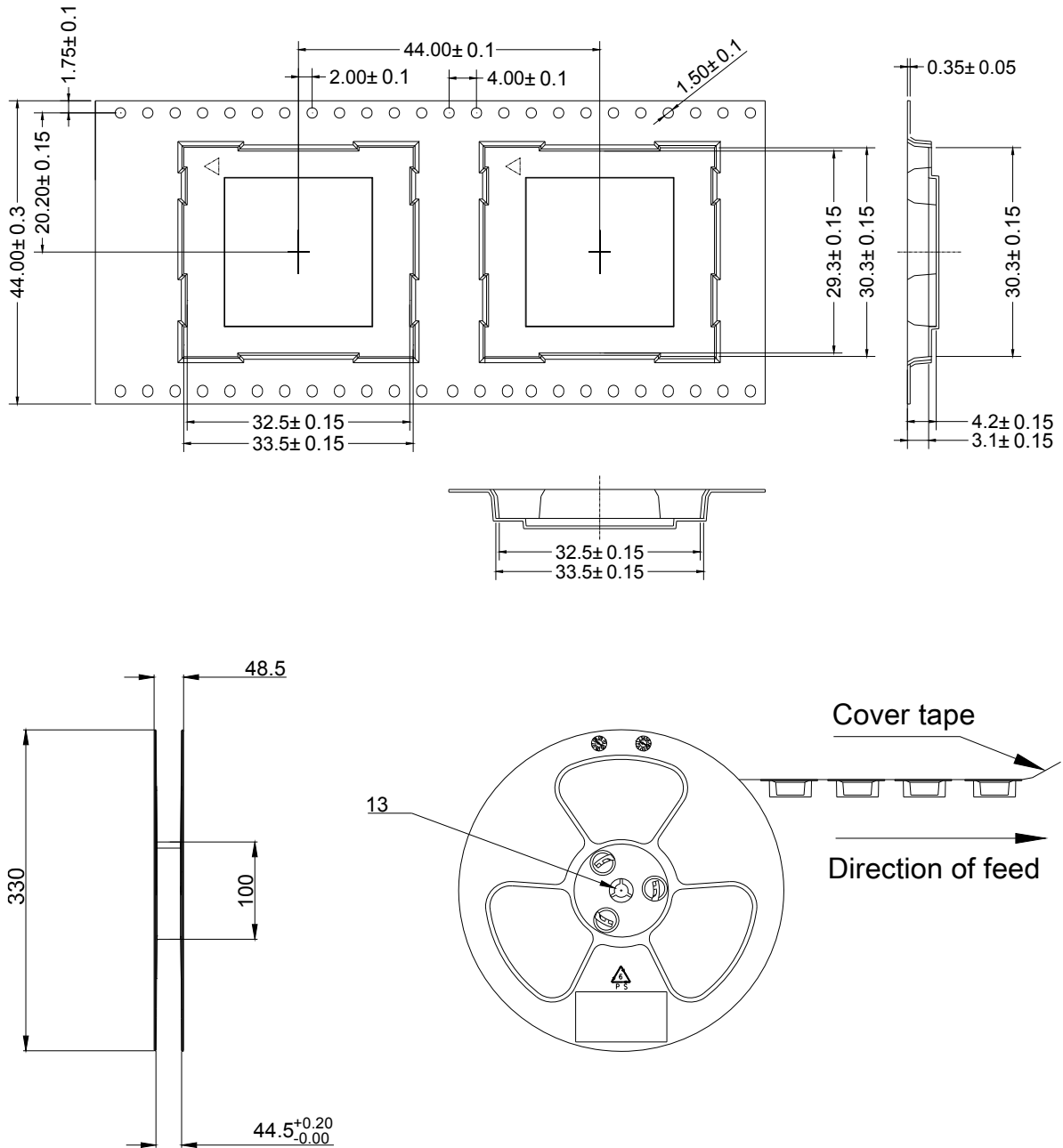


Figure 46: Tape and Reel Specifications



# 9 Appendix A References

**Table 51: Related Documents**

SN	Document Name	Remark
[1]	Quectel_EC21_Power_Management_Application_Note	EC21 Power Management Application Note
[2]	Quectel_EC25&EC21_AT_Commands_Manual	EC25 and EC21 AT Commands Manual
[3]	Quectel_EC25&EC21_GNSS_AT_Commands_Manual	EC25 and EC21GNSS AT Commands Manual
[4]	Quectel_Module_Secondary_SMT_User_Guide	Module Secondary SMT User Guide
[5]	Quectel_EC21_Reference_Design	EC21 Reference Design
[6]	Quectel_RF_Layout_Application_Note	RF Layout Application Note
[7]	Quectel_SGMII_Design_Application_Note	SGMII Design Application Note

**Table 52: Terms and Abbreviations**

Abbreviation	Description
AMR	Adaptive Multi-rate
bps	Bits Per Second
CHAP	Challenge Handshake Authentication Protocol
CS	Coding Scheme
CSD	Circuit Switched Data
CTS	Clear To Send
DC-HSPA+	Dual-carrier High Speed Packet Access
DFOTA	Delta Firmware Upgrade Over The Air

DL	Downlink
DTR	Data Terminal Ready
DTX	Discontinuous Transmission
EFR	Enhanced Full Rate
ESD	Electrostatic Discharge
FDD	Frequency Division Duplex
FR	Full Rate
GLONASS	GLOBALnayaNAVigatsionnayaSputnikovayaSistema, the Russian Global Navigation Satellite System
GMSK	Gaussian Minimum Shift Keying
GNSS	Global Navigation Satellite System
GPS	Global Positioning System
GSM	Global System for Mobile Communications
HR	Half Rate
HSPA	High Speed Packet Access
HSDPA	High Speed Downlink Packet Access
HSUPA	High Speed Uplink Packet Access
I/O	Input/Output
Inorm	Normal Current
LED	Light Emitting Diode
LNA	Low Noise Amplifier
LTE	Long Term Evolution
MIMO	Multiple Input Multiple Output
MO	Mobile Originated
MS	Mobile Station (GSM engine)
MT	Mobile Terminated

---

PAP	Password Authentication Protocol
PCB	Printed Circuit Board
PDU	Protocol Data Unit
PPP	Point-to-Point Protocol
QAM	Quadrature Amplitude Modulation
QPSK	Quadrature Phase Shift Keying
RF	Radio Frequency
RHCP	Right Hand Circularly Polarized
Rx	Receive
SGMII	Serial Gigabit Media Independent Interface
SIM	Subscriber Identification Module
SIMO	Single Input Multiple Output
SMS	Short Message Service
TDD	Time Division Duplexing
TDMA	Time Division Multiple Access
TD-SCDMA	Time Division-Synchronous Code Division Multiple Access
TX	Transmitting Direction
UL	Uplink
UMTS	Universal Mobile Telecommunications System
URC	Unsolicited Result Code
USIM	Universal Subscriber Identity Module
V <sub>max</sub>	Maximum Voltage Value
V <sub>norm</sub>	Normal Voltage Value
V <sub>min</sub>	Minimum Voltage Value
V <sub>IHmax</sub>	Maximum Input High Level Voltage Value

---

---

$V_{IHmin}$	Minimum Input High Level Voltage Value
$V_{ILmax}$	Maximum Input Low Level Voltage Value
$V_{ILmin}$	Minimum Input Low Level Voltage Value
$V_{Imax}$	Absolute Maximum Input Voltage Value
$V_{Imin}$	Absolute Minimum Input Voltage Value
$V_{OHmax}$	Maximum Output High Level Voltage Value
$V_{OHmin}$	Minimum Output High Level Voltage Value
$V_{OLmax}$	Maximum Output Low Level Voltage Value
$V_{OLmin}$	Minimum Output Low Level Voltage Value
VSWR	Voltage Standing Wave Ratio
WCDMA	Wideband Code Division Multiple Access
WLAN	Wireless Local Area Network

---

# 10 Appendix B GPRS Coding Schemes

Table 53: Description of Different Coding Schemes

Scheme	CS-1	CS-2	CS-3	CS-4
Code Rate	1/2	2/3	3/4	1
USF	3	3	3	3
Pre-coded USF	3	6	6	12
Radio Block excl.USF and BCS	181	268	312	428
BCS	40	16	16	16
Tail	4	4	4	-
Coded Bits	456	588	676	456
Punctured Bits	0	132	220	-
Data Rate Kb/s	9.05	13.4	15.6	21.4

# 11 Appendix C GPRS Multi-slot Classes

Twenty-nine classes of GPRS multi-slot modes are defined for MS in GPRS specification. Multi-slot classes are product dependent, and determine the maximum achievable data rates in both the uplink and downlink directions. Written as 3+1 or 2+2, the first number indicates the amount of downlink timeslots, while the second number indicates the amount of uplink timeslots. The active slots determine the total number of slots the GPRS device can use simultaneously for both uplink and downlink communications.

The description of different multi-slot classes is shown in the following table.

**Table 54: GPRS Multi-slot Classes**

Multislot Class	Downlink Slots	Uplink Slots	Active Slots
1	1	1	2
2	2	1	3
3	2	2	3
4	3	1	4
5	2	2	4
6	3	2	4
7	3	3	4
8	4	1	5
9	3	2	5
10	4	2	5
11	4	3	5
12	4	4	5

# 12 Appendix D EDGE Modulation and Coding Schemes

Table 55: EDGE Modulation and Coding Schemes

Coding Scheme	Modulation	Coding Family	1 Timeslot	2 Timeslot	4 Timeslot
CS-1:	GMSK	/	9.05kbps	18.1kbps	36.2kbps
CS-2:	GMSK	/	13.4kbps	26.8kbps	53.6kbps
CS-3:	GMSK	/	15.6kbps	31.2kbps	62.4kbps
CS-4:	GMSK	/	21.4kbps	42.8kbps	85.6kbps
MCS-1	GMSK	C	8.80kbps	17.60kbps	35.20kbps
MCS-2	GMSK	B	11.2kbps	22.4kbps	44.8kbps
MCS-3	GMSK	A	14.8kbps	29.6kbps	59.2kbps
MCS-4	GMSK	C	17.6kbps	35.2kbps	70.4kbps
MCS-5	8-PSK	B	22.4kbps	44.8kbps	89.6kbps
MCS-6	8-PSK	A	29.6kbps	59.2kbps	118.4kbps
MCS-7	8-PSK	B	44.8kbps	89.6kbps	179.2kbps
MCS-8	8-PSK	A	54.4kbps	108.8kbps	217.6kbps
MCS-9	8-PSK	A	59.2kbps	118.4kbps	236.8kbps