

SC20-W Manual

Smart Wi-Fi Module Series

Rev: SC20-W_Manual_R1.0

Date: 2017-08-04



Our aim is to provide customers with timely and comprehensive service. For any assistance, please contact our company headquarters:

Quectel Wireless Solutions Co., Ltd.

7th Floor, Hongye Building, No.1801 Hongmei Road, Xuhui District, Shanghai 200233, China

Tel: +86 21 5108 6236

Email: info@quectel.com

Or our local office. For more information, please visit:

<http://www.quectel.com/support/salesupport.aspx>

For technical support, or to report documentation errors, please visit:

<http://www.quectel.com/support/techsupport.aspx>

Or email to: Support@quectel.com

GENERAL NOTES

QUECTEL OFFERS THE INFORMATION AS A SERVICE TO ITS CUSTOMERS. THE INFORMATION PROVIDED IS BASED UPON CUSTOMERS' REQUIREMENTS. QUECTEL MAKES EVERY EFFORT TO ENSURE THE QUALITY OF THE INFORMATION IT MAKES AVAILABLE. QUECTEL DOES NOT MAKE ANY WARRANTY AS TO THE INFORMATION CONTAINED HEREIN, AND DOES NOT ACCEPT ANY LIABILITY FOR ANY INJURY, LOSS OR DAMAGE OF ANY KIND INCURRED BY USE OF OR RELIANCE UPON THE INFORMATION. ALL INFORMATION SUPPLIED HEREIN IS SUBJECT TO CHANGE WITHOUT PRIOR NOTICE.

COPYRIGHT

THE INFORMATION CONTAINED HERE IS PROPRIETARY TECHNICAL INFORMATION OF QUECTEL CO., LTD. TRANSMITTING, REPRODUCTION, DISSEMINATION AND EDITING OF THIS DOCUMENT AS WELL AS UTILIZATION OF THE CONTENT ARE FORBIDDEN WITHOUT PERMISSION. OFFENDERS WILL BE HELD LIABLE FOR PAYMENT OF DAMAGES. ALL RIGHTS ARE RESERVED IN THE EVENT OF A PATENT GRANT OR REGISTRATION OF A UTILITY MODEL OR DESIGN.

Copyright © Quectel Wireless Solutions Co., Ltd. 2017. All rights reserved.

About the Document

History

Revision	Date	Author	Description
1.0	2017-08-04	NINA DOU	SC20-W_Manual_R1.0

Contents

About the Document	2
Contents	3
1 Introduction	5
1.1. Safety Information.....	5
2 Product Concept	7
2.1. General Description	7
2.2. Key Features	8
2.3. Functional Diagram	10
2.4. Evaluation Board	11
3 Application Interfaces	12
3.1. General Description	12
3.2. Pin Assignment	13
3.3. Power Supply.....	14
3.4. Turn on and off Scenarios	14
3.4.1. Turn on Module Using the PWRKEY	14
3.4.2. Turn off Module	15
3.5. VRTC Interface	16
3.6. Power Output.....	17
3.7. Battery Charge and Management	17
3.8. USB Interface	18
4 Wi-Fi and BT	19
4.1. Wi-Fi Overview	19
4.2. BT Overview	19
5 Antenna Interface	21
5.1. Wi-Fi/BT Antenna Interface	21
5.1.1. Reference Design of RF Layout.....	22
5.2. Antenna Installation	24
5.2.1. Antenna Requirements	24
5.2.2. Recommended RF Connector for Antenna Installation	24
6 Electrical, Reliability and Radio Characteristics	27
6.1. Absolute Maximum Ratings.....	27
6.2. Power Supply Ratings	27
6.3. Charging Performance Specifications	28
6.4. Operating Temperature.....	28
6.5. Current Consumption	29
6.6. Electrostatic Discharge.....	30
7 Mechanical Dimensions	31

7.1.	Mechanical Dimensions of the Module.....	31
7.2.	Recommended Footprint.....	33
7.3.	Top and Bottom View of the Module.....	34
8	Storage, Manufacturing and Packaging.....	35
8.1.	Storage.....	35
8.2.	Manufacturing and Welding.....	36
8.3.	Packaging.....	37
9	IC & FCC Requirement.....	39
9.1.	FCC Regulations:.....	39
9.2.	RF Exposure Information.....	39
9.3.	ISED Notice.....	39
9.4.	ISED Radiation Exposure Statement.....	40
9.5.	IMPORTANT NOTE:.....	40
9.6.	USERS MANUAL OF THE END PRODUCT:.....	40
9.7.	LABEL OF THE END PRODUCT:.....	41

1 Introduction

This document defines the SC20-W module and describes its air interface and hardware interface which are connected with your application.

This document can help you quickly understand module interface specifications, electrical and mechanical details as well as other related information of SC20-W module. Associated with application note and user guide, you can use SC20-W module to design and set up mobile applications easily.

1.1. Safety Information

The following safety precautions must be observed during all phases of operation, such as usage, service or repair of any cellular terminal or mobile incorporating SC20-W module. Manufacturers of the cellular terminal should send the following safety information to users and operating personnel, and incorporate these guidelines into all manuals supplied with the product. If not so, Quectel assumes no liability for the customer's failure to comply with these precautions.



Full attention must be given to driving at all times in order to reduce the risk of an accident. Using a mobile while driving (even with a handsfree kit) causes distraction and can lead to an accident. You must comply with laws and regulations restricting the use of wireless devices while driving.



Switch off the cellular terminal or mobile before boarding an aircraft. Make sure it is switched off. The operation of wireless appliances in an aircraft is forbidden, so as to prevent interference with communication systems. Consult the airline staff about the use of wireless devices on boarding the aircraft, if your device offers an Airplane Mode which must be enabled prior to boarding an aircraft.



Switch off your wireless device when in hospitals, clinics or other health care facilities. These requests are designed to prevent possible interference with sensitive medical equipment.



Cellular terminals or mobiles operating over radio frequency signal and cellular network cannot be guaranteed to connect in all conditions, for example no mobile fee or with an invalid USIM/SIM card. While you are in this condition and need emergent help, please remember using emergency call. In order to make or receive a call, the cellular terminal or mobile must be switched on and in a service area with adequate cellular signal strength.



Your cellular terminal or mobile contains a transmitter and receiver. When it is ON, it receives and transmits radio frequency energy. RF interference can occur if it is used close to TV set, radio, computer or other electric equipment.



In locations with potentially explosive atmospheres, obey all posted signs to turn off wireless devices such as your phone or other cellular terminals. Areas with potentially explosive atmospheres include fuelling areas, below decks on boats, fuel or chemical transfer or storage facilities, areas where the air contains chemicals or particles such as grain, dust or metal powders, etc.



Please do not discard. Maybe wireless devices have an impact on the environment so please do not arbitrarily discarded.



The device is restricted to indoor use only when operating in the 5150 to 5350 Mhz frequency range.

AT	BE	BG	HR	CY	CZ	DK
EE	FI	FR	DE	EL	HU	IE
IT	LV	LT	LU	MT	NL	PL
PT	RO	SK	SI	ES	SE	UK

2 Product Concept

2.1. General Description

SC20-W is a Smart Wi-Fi module based on Qualcomm platform and Android operating system, and provides industrial grade performance. It supports Wi-Fi 802.11a/b/g/n and BT4.1 LE standards for short-range wireless communication. The module also offers multiple audio and video input/output interfaces as well as abundant GPIO interfaces.

The following table shows the supported Wi-Fi/BT standards and frequency range of SC20-W.

Table 1: SC20-W Frequency Bands

Type	Frequency Range
IEEE 802.11b/g/n	2412-2462MHz
IEEE 802.11a/n	5180~5825MHz
BT4.1 LE	2402-2480MHz

SC20-W is an SMD type module, which can be embedded into applications through its 210-pin pads including 146 LCC signal pads and 64 other pads. With a compact profile of 40.5mm × 40.5mm × 2.8mm, SC20-W can meet almost all requirements for M2M applications such as CPE, wireless POS, smart metering, automotive, digital signage, alarm panel, security and industrial PDA.

2.2. Key Features

The following table describes the detailed features of SC20-W module.

Table 2: SC20-W Key Features

Feature	Details
Applications Processor	ARM Cortex-A7 microprocessor cores (quad-core) up to 1.1 GHz 512KB L2 cache
Modem DSP	QDSP6 v5 core up to 691.2MHz 768KB L2 cache
Memory	8GB EMMC+8Gb LPDDR3
Operating System	Android OS 5.1
Power Supply	Supply voltage: 3.5V~4.2V Typical supply voltage: 3.8V
WLAN Features	2.4G and 5G double frequency bands Support 802.11a/b/g/n standards, with max. data rate up to 150Mbps Support AP mode
Bluetooth Feature	BT4.1 LE
AT Commands	3GPP TS 27.007 and 3GPP TS 27.005 AT commands as well as Quectel enhanced AT commands
LCM Interface	4-lane MIPI_DSI, up to 1.5Gbps for each lane Support WVGA (2-lane MIPI_DSI), up to 720p (4-lane MIPI_DSI) 24-bit color depth
Camera Interface	Use MIPI_CSI, up to 1.5Gbps per lane Support two cameras: 2-lane MIPI_CSI for rear camera, max. pixel up to 8MP 1-lane MIPI_CSI for front camera, max. pixel up to 2MP
Audio Interface	Audio input 2 groups of analog microphone input, integrate internal bias voltage Audio output Class AB stereo headphone output Class AB earpiece differential output Class D speaker differential amplifier output
USB Interface	Compliant with USB 2.0 specification; the data transfer rate can reach up to 480Mbps Used for AT command communication, data transmission, software debugging and firmware upgrade Support USB OTG (Need additional 5V power supply chip)

	USB Driver: Support Windows XP, Windows Vista, Windows 7, Windows 8, Windows CE5.0/6.0*, Linux 2.6/3.0, Android 2.3/4.0/4.2
UART Interface	2 UART interfaces: 4-wire UART interface with RTS and CTS hardware flow control 2-wire UART interface for software debugging Baud rate up to 4Mbps
SDIO Interface	Support SD3.0, 4-bit SDIO Support hot plug
I2C Interface	3 groups of I2C, with max. data rate up to 3.4Mbps (High Speed) Used for peripherals such as camera, sensor, touch panel, etc.
ADC Interface	Support 3 ADC interfaces; Used for input voltage sense, battery temperature detection and general purpose ADC
Real Time Clock	Supported
Physical Characteristics	Size: (40.5±0.15)mm × (40.5±0.15)mm × (2.8±0.2) mm Interface: LCC Weight: approx. 9.8g
Temperature Range	Operating temperature range: -35°C~+65°C ¹⁾ Extended temperature range : -40°C~+75°C ²⁾
Firmware Upgrade	Over USB interface
RoHS	All hardware components are fully compliant with EU RoHS directive

NOTE:

1. ¹⁾ Within operation temperature range, the module is IEEE compliant.
2. ²⁾ Within extended temperature range, the module remains the ability for data transmission. There is no unrecoverable malfunction. There are also no effects on radio spectrum and no harm to radio network. Only one or more parameters like P_{out} might reduce in their value and exceed the specified tolerances. When the temperature returns to the normal operating temperature levels, the module will meet IEEE compliant again.
3. “*” means under development.

2.3. Functional Diagram

The following figure shows a block diagram of SC20-W and illustrates the major functional parts.

- Power management
- Radio frequency
- Baseband
- LPDDR3+EMMC flash
- Peripheral interface
 - USB interface
 - UART interface
 - SDIO interface
 - I2C interface
 - ADC interface
 - LCM (MIPI) interface
 - Touch Panel interface
 - Camera (MIPI) interface
 - Audio interface

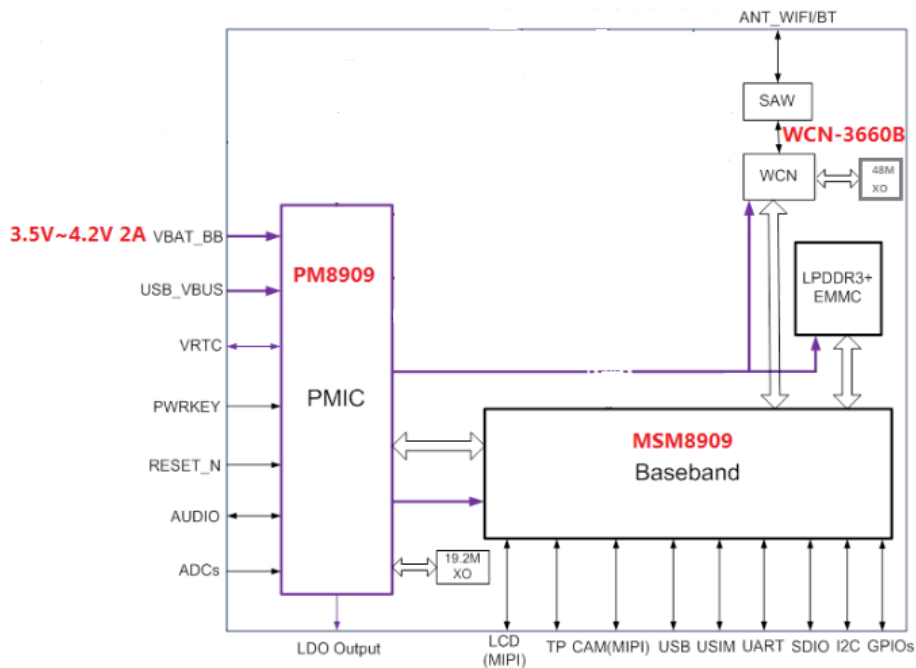

Figure 1: Functional Diagram

2.4. Evaluation Board

In order to help you to develop applications with SC20-W, Quectel supplies the evaluation board (Smart-EVB), RS-232 to USB cable, USB data cable, power adapter, earphone, antenna and other peripherals to control or test the module. For more details, please refer to **document [1]**.

3 Application Interfaces

3.1. General Description

SC20-W is equipped with 146-pin 1.0mm pitch SMT pads plus 64-pin ground pads and reserved pads that can be embedded into wireless application platforms. The following chapters provide the detailed description of pins/interfaces listed below.

- Power supply
- VRTC interface
- LCM interface
- TP interface
- Camera interface
- Audio interface
- USB interface
- UART interface
- SDIO interface
- I2C interface
- ADC interface

3.2. Pin Assignment

The following figure shows the pin assignment of SC20-W module.

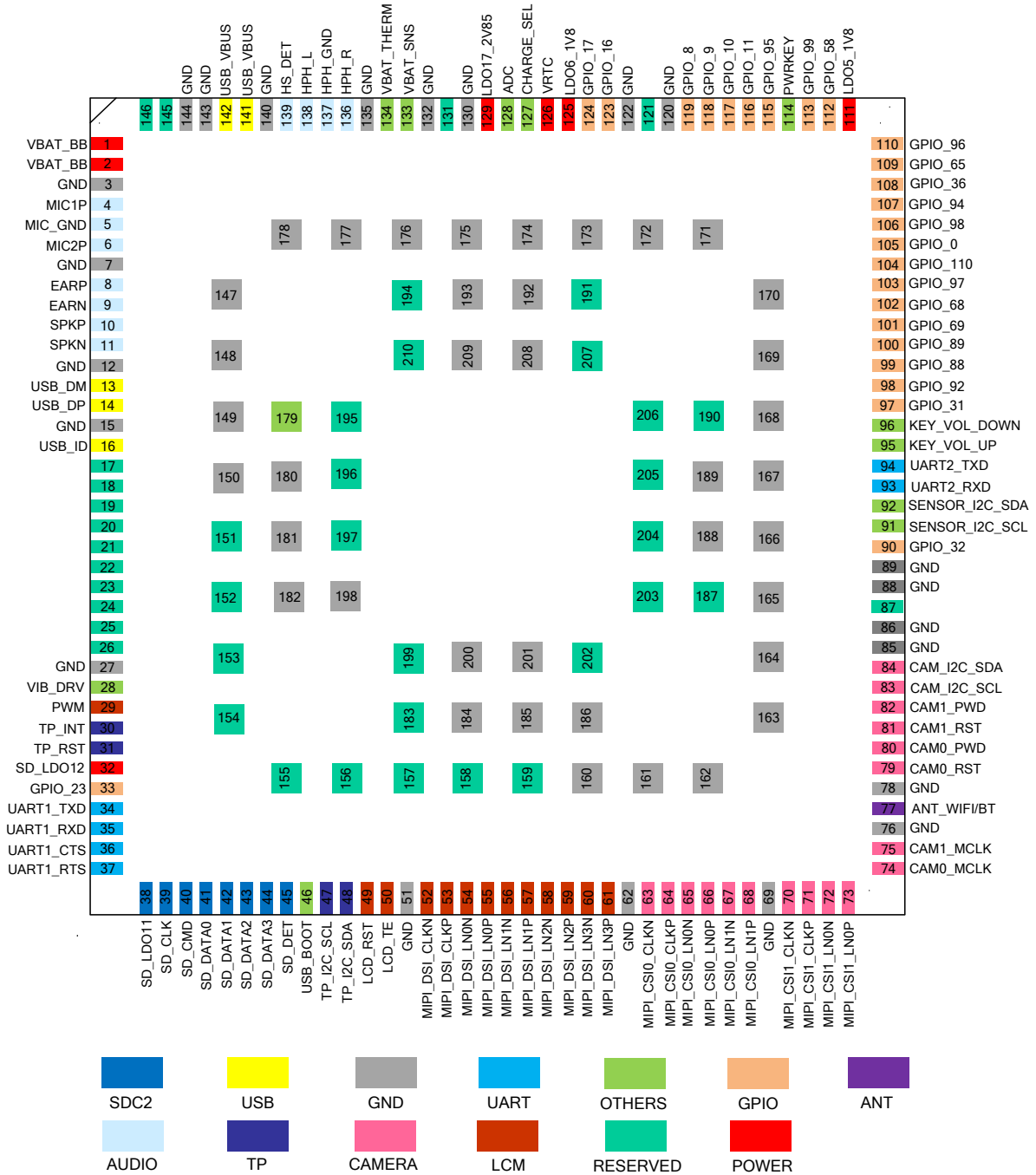

Figure 2: Pin Assignment (Top View)

3.3. Power Supply

SC20-W provides two VBAT pins dedicated to connection with the external power supply. The two VBAT_BB pins are used for module baseband part. The power supply range of the module is 3.5V~4.2V, and the recommended value is 3.8V.

3.4. Turn on and off Scenarios

3.4.1. Turn on Module Using the PWRKEY

The module can be turned on by driving PWRKEY pin to a low level for at least 1.6s. PWRKEY pin is pulled to 1.8V internally. It is recommended to use an open drain/collector driver to control the PWRKEY. A simple reference circuit is illustrated in the following figure.

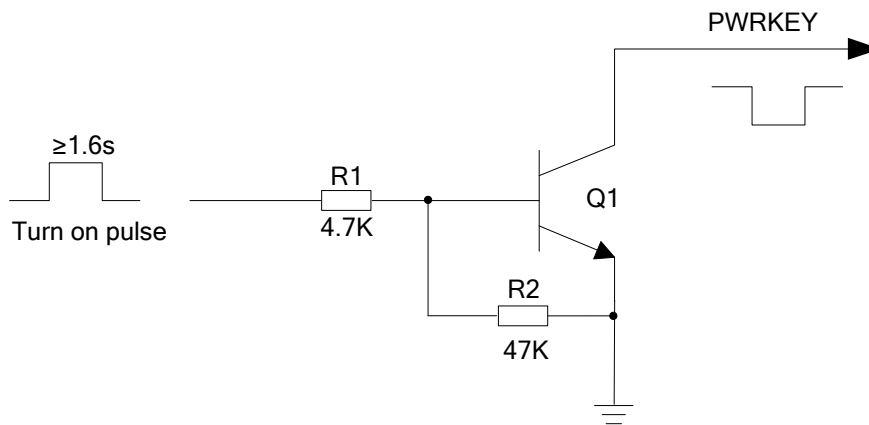

Figure 3: Turn on the Module Using Driving Circuit

The other way to control the PWRKEY is using a button directly. A TVS component is indispensable to be placed nearby the button for ESD protection. A reference circuit is shown in the following figure.

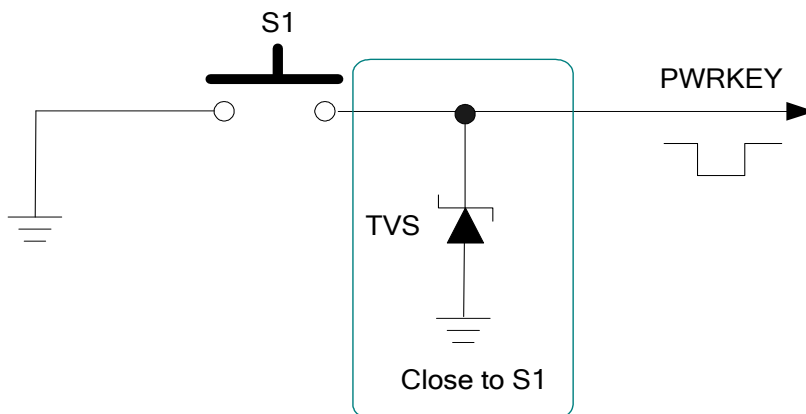

Figure 4: Turn on the Module Using Keystroke

The turn on scenario is illustrated in the following figure.

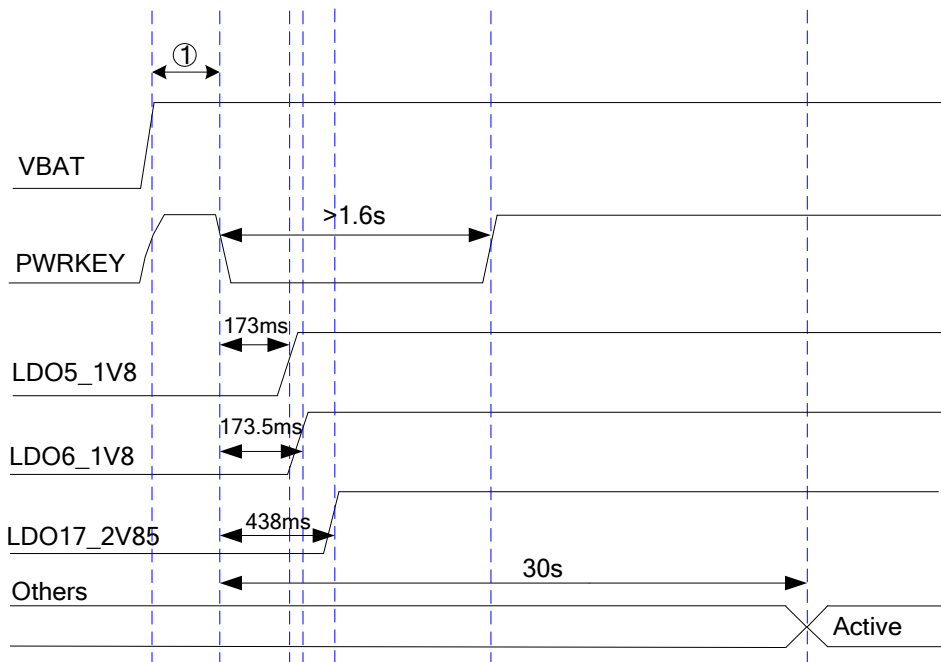

Figure 5: Timing of Turning on Module

NOTE:

Make sure that VBAT is stable before pulling down PWRKEY pin. The recommended time between them is no less than 30ms. PWRKEY pin cannot be pulled down all the time.

3.4.2. Turn off Module

Set the PWRKEY pin low for at least 1s, and then choose to turn off the module when the prompt window comes up.

The other way to turn off the module is to drive PWRKEY to a low level for at least 8s. The module will execute forced shutdown. The forced power-down scenario is illustrated in the following figure.

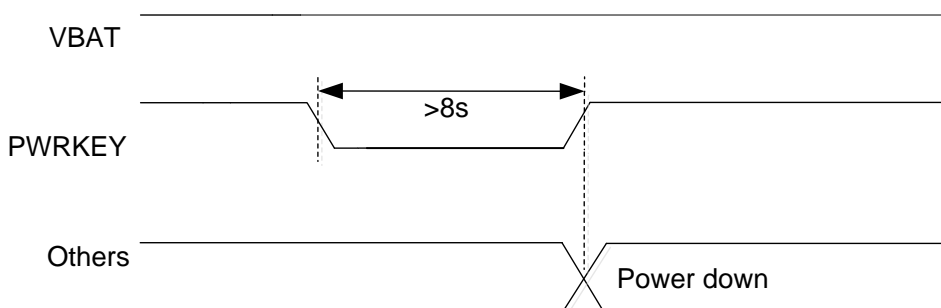

Figure 6: Timing of Turning off Module

3.5. VRTC Interface

The RTC (Real Time Clock) can be powered by an external power source through VRTC when the module is powered down and there is no power supply for the VBAT. The external power source can be capacitor, rechargeable battery or non-rechargeable battery according to application demands. The following are some reference circuit designs when an external battery or capacitor is utilized for powering RTC.

If RTC is ineffective, it can be synchronized when the module starts data connection after power on.

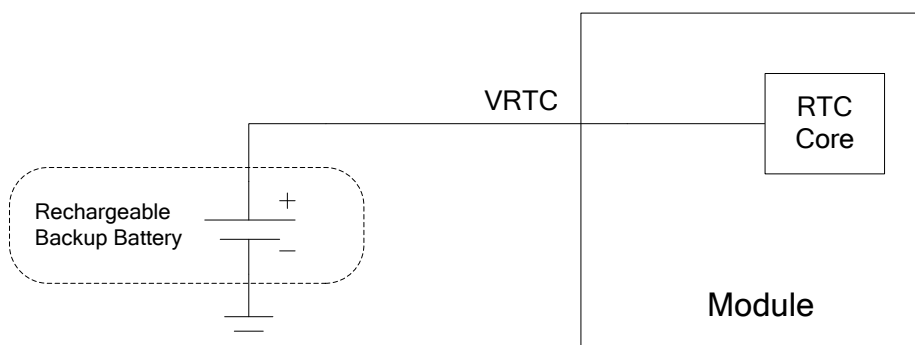

Figure 7: RTC Powered by Rechargeable Battery

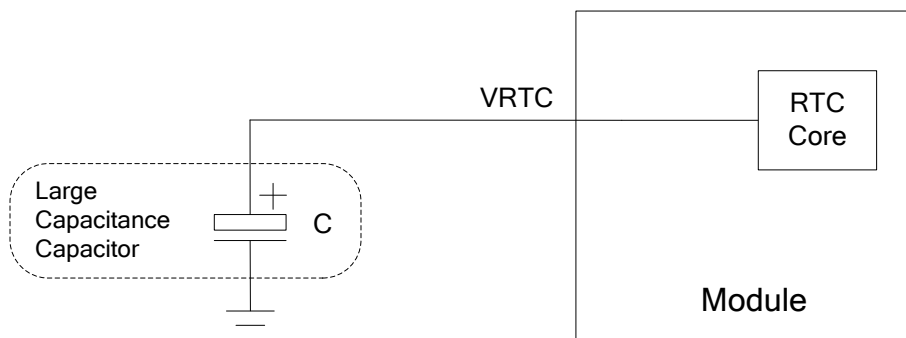

Figure 8: RTC Powered by Capacitor

- 2.0~3.25V input voltage range and 3.0V typical value for VRTC. When VBAT is disconnected, the average consumption is 5uA.
- When powered by VBAT, the RTC error is 50ppm. When powered by VRTC, the RTC error is 200ppm.
- If the rechargeable battery is used, the ESR of the battery should be less than 2K, and it is recommended to use the MS621FE FL11E of SEIKO.
- If a large capacitance capacitor is selected, it is recommended to use a 100uF capacitor with low

ESR. The capacitor is able to power the real-time clock for 45 seconds.

3.6. Power Output

SC20-W supports output of regulated voltages for peripheral circuits.

Table 3: Power Description

Pin Name	Voltage Range (V)	Default Voltage (V)	Driving Current (mA)	IDLE
LDO5_1V8	1.75~3.337	1.8	20	KEEP
LDO6_1V8	1.75~3.337	1.8	100	No output
LDO17_2V85	1.75~3.337	2.85	300	No output
SD_LDO12	1.75~3.337	2.95	50	
SD_LDO11	1.75~3.337	2.95	600	

3.7. Battery Charge and Management

SC20-W module can recharge over-discharged batteries. The battery charger in SC20-W module supports trickle charging, constant current charging and constant voltage charging modes, which optimizes the charging procedure for Li-ion batteries.

- Trickle charging: There are two steps in this mode. When the battery voltage is below 2.8V, a 90mA trickle charging current is applied to the battery. When the battery voltage is charged up and is between 2.8V and 3.2V, the charging current can be set to 450mA maximally.
- Constant current mode (CC mode): When the battery is increased to between 3.2V and 4.2V, the system will switch to CC mode. The maximum charging current is 1.44A when adapter is used for battery charging; and the maximum charging current is 450mA while USB charging.
- Constant voltage mode (CV mode): When the battery voltage reaches the final value 4.2V, the system will switch to CV mode and the charging current will decrease gradually. When the battery level reaches 100%, the charging is completed.

SC20-W module supports battery temperature detection in the condition that the battery integrates a thermistor (47K 1%, B4050 NTC thermistor by default; SDNT1608X473F4050FTF of SUNLORD is recommended) and the thermistor is connected to VBAT_THERM pin. The default temperature range is from -3.0 to 48.5°C. If VBAT_THERM pin is not connected, there will be malfunctions such as battery charging failure, battery level display error, etc.

A reference design for battery charging circuit is shown as below.

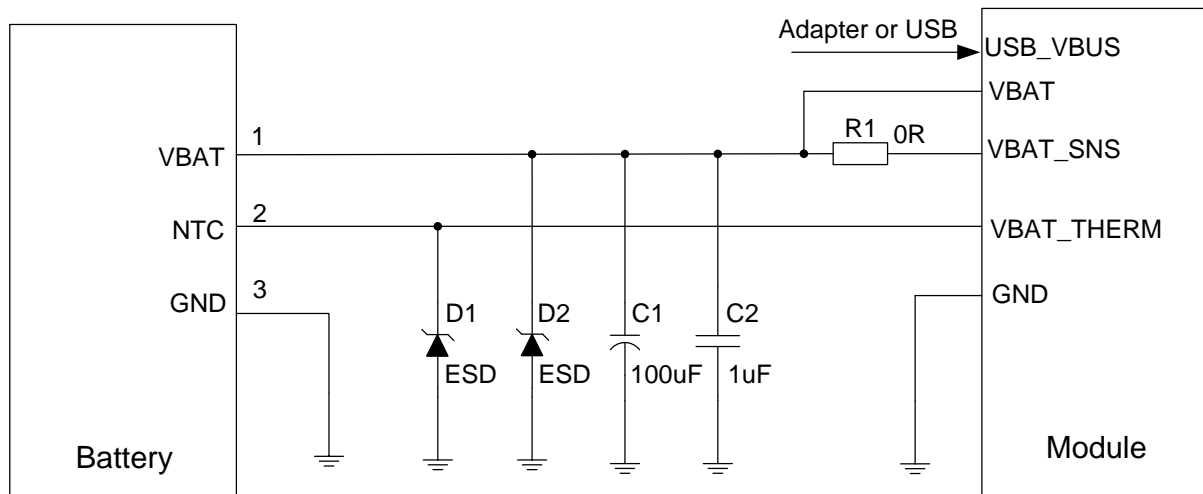

Figure 9: Reference Design for Battery Charging Circuit

Mobile devices such as mobile phones and handheld POS systems are powered by batteries. When different batteries are utilized, the charging and discharging curve has to be modified correspondingly so as to achieve the best effect.

If thermistor is not available in the battery, or adapter is utilized for powering module, then there is only a need for VBAT and GND connection. In this case, the system may mistakenly judge that the battery temperature is abnormal, which will cause battery charging failure. In order to avoid this, VBAT_THERM should be connected to GND with a 47KΩ resistor. If VBAT_THERM is unconnected, the system will be unable to detect the battery, making battery cannot be charged.

VBAT_SNS pin must be connected. Otherwise, the module will have abnormalities in voltage detection, as well as associated power on/off and battery charging/discharging issues.

3.8. USB Interface

SC20-W contains one integrated Universal Serial Bus (USB) transceiver which complies with the USB 2.0 specification and supports high speed (480 Mbps) and full speed (12 Mbps) modes. The USB interface is used for AT command communication, data transmission, software debugging and firmware upgrade.

4 Wi-Fi and BT

SC20-W module provides a shared antenna interface ANT_WIFI/BT for Wi-Fi and Bluetooth (BT) functions. The interface impedance is 50Ω. External antennas such as dipole antenna can be connected to the module via the interface, so as to achieve Wi-Fi and BT functions.

4.1. Wi-Fi Overview

SC20-W module supports 2.4G and 5G double-bands WLAN wireless communication based on IEEE 802.11 a/802.11 b/ 802.11g/ 802.11n standard protocols. The maximum data rate is up to 150 Mbps.

The features are as below:

- Support Wake-on-WLAN (WoWLAN)
- Support ad hoc mode
- Support WAPI SMS4 hardware encryption
- Support AP mode
- Support Wi-Fi Direct
- Support MCS 0-7 for HT20 and HT40

4.2. BT Overview

SC20-W module supports BT4.1 (BR/EDR+BLE) specification, as well as GFSK, 8-DPSK, $\pi/4$ -DQPSK modulation modes.

- Maximally support up to 7 wireless connections.
- Maximally support up to 3.5 piconets at the same time.
- Support one SCO (Synchronous Connection Oriented) or eSCO connection.

The BR/EDR channel bandwidth is 1MHz, and can accommodate 79 channels. The BLE channel bandwidth is 2MHz, and can accommodate 40 channels.

Table 4: BT Data Rate and Version

Version	Data rate	Maximum Application Throughput	Comment
1.2	1 Mbit/s	>80 Kbit/s	
2.0 + EDR	3 Mbit/s	>80 Kbit/s	
3.0 + HS	24 Mbit/s	Reference 3.0 + HS	
4.0	24 Mbit/s	Reference 4.0 LE	

Referenced specifications are listed below:

- Bluetooth Radio Frequency TSS and TP Specification 1.2/2.0/2.0 + EDR/2.1/2.1+ EDR/3.0/3.0 + HS, August 6, 2009
- Bluetooth Low Energy RF PHY Test Specification, RF-PHY.TS/4.0.0, December 15, 2009

5 Antenna Interface

SC20-W antenna interface includes a Wi-Fi/BT antenna. The antenna interface has an impedance of 50Ω.

5.1. Wi-Fi/BT Antenna Interface

The following tables show the Wi-Fi/BT antenna pin's definition and frequency specification.

Table 5: Pin Definition of Wi-Fi/BT Antenna

Pin Name	Pin No.	I/O	Description	Comment
ANT_WIFI/BT	77	IO	Wi-Fi/BT antenna	50Ω impedance

Table 6: Wi-Fi/BT Frequency

Type	Frequency	Unit
Wi-Fi(2.4G)	2412-2462	MHz
Wi-Fi(5G)	5180~5825	MHz
BT4.1 LE	2402~2480	MHz

A reference circuit design for Wi-Fi/BT antenna is shown as below. A π -type matching circuit should be reserved for better RF performance. The capacitors are not mounted by default.

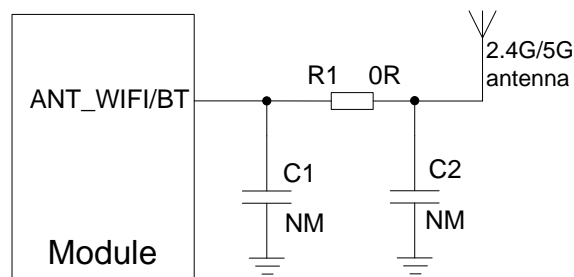

Figure 10: Reference Circuit Design for Wi-Fi/BT Antenna

NOTE:

Place the π -type matching components (R1, C1, C2) as close to the antenna as possible.

5.1.1. Reference Design of RF Layout

For user's PCB, the characteristic impedance of all RF traces should be controlled as 50Ω . The impedance of the RF traces is usually determined by the trace width (W), the materials' dielectric constant, the distance between signal layer and reference ground (H), and the clearance between RF trace and ground (S). Microstrip line or coplanar waveguide line is typically used in RF layout for characteristic impedance control. The following are reference designs of microstrip line or coplanar waveguide line with different PCB structures.

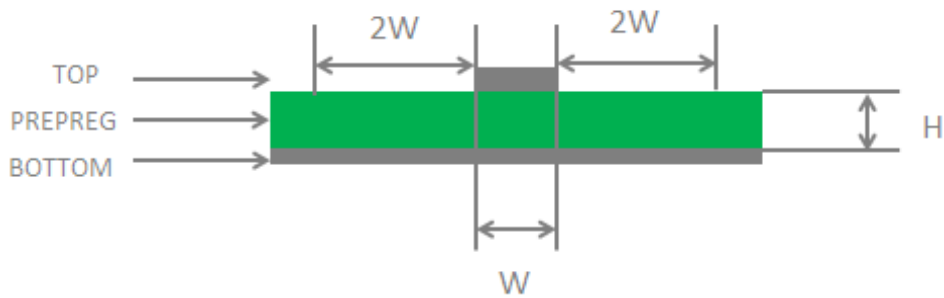

Figure 11: Microstrip Line Design on a 2-layer PCB

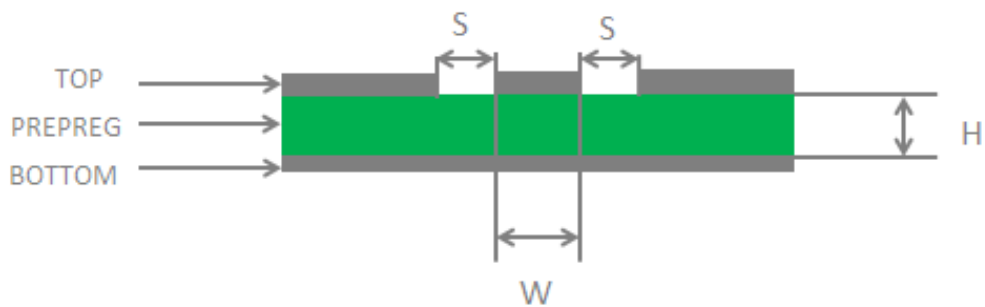

Figure 12: Coplanar Waveguide Line Design on a 2-layer PCB

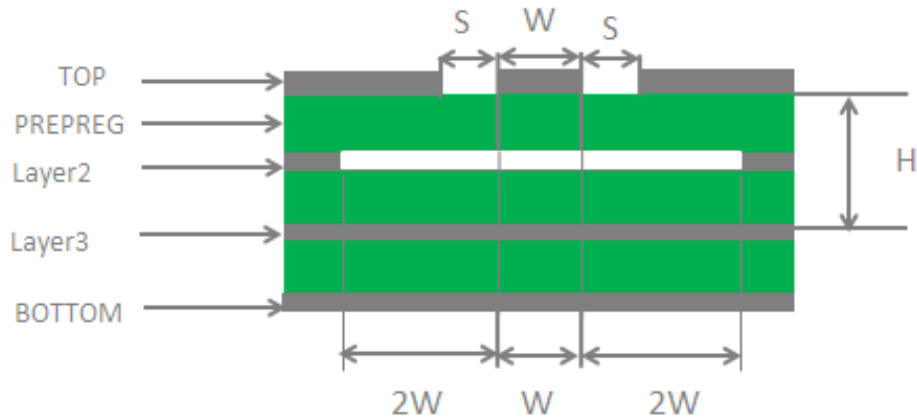

Figure 13: Coplanar Waveguide Line Design on a 4-layer PCB (Layer 3 as Reference Ground)

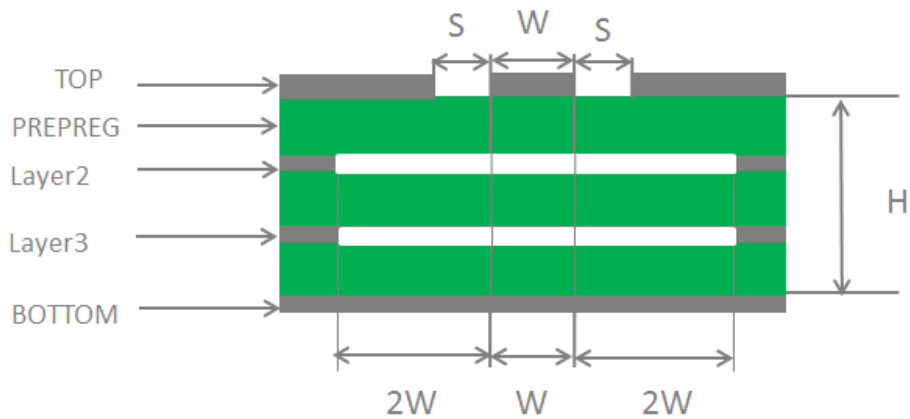

Figure 14: Coplanar Waveguide Line Design on a 4-layer PCB (Layer 4 as Reference Ground)

In order to ensure RF performance and reliability, the following principles should be complied with in RF layout design:

- Use impedance simulation tool to control the characteristic impedance of RF traces as 50Ω .
- The GND pins adjacent to RF pins should not be hot welded, and should be fully connected to ground.
- The distance between the RF pins and the RF connector should be as short as possible, and all the right angle traces should be changed to curved ones.
- There should be clearance area under the signal pin of the antenna connector or solder joint.
- The reference ground of RF traces should be complete. Meanwhile, adding some ground vias around RF traces and the reference ground could help to improve RF performance. The distance between the ground vias and RF traces should be no less than two times the width of RF signal traces ($2*W$).

For more details about RF layout, please refer to **document [3]**.

5.2. Antenna Installation

5.2.1. Antenna Requirements

The following table shows the requirements on Wi-Fi/BT antenna.

Table 7: Antenna Requirements

Type	Requirements
Wi-Fi/BT	VSWR: ≤ 2 Max Input Power (W): 50 Input Impedance (Ω): 50 Polarization Type: Vertical Cable Insertion Loss: < 1 dB

The WiFi2.4GHz/WiFi5GHz/Bluetooth dipole antenna information as below:

Manufacturer	Model	Peak gain
INPAQ TECHNOLOGY CO., LTD	DAM-L0-H-N0-000-08-13	WiFi2.4GHz/Bluetooth: 3.0 dBi
		WiFi5GHz: 4.0 dBi

5.2.2. Recommended RF Connector for Antenna Installation

If RF connector is used for antenna connection, it is recommended to use the UF.L-R-SMT connector provided by HIROSE.

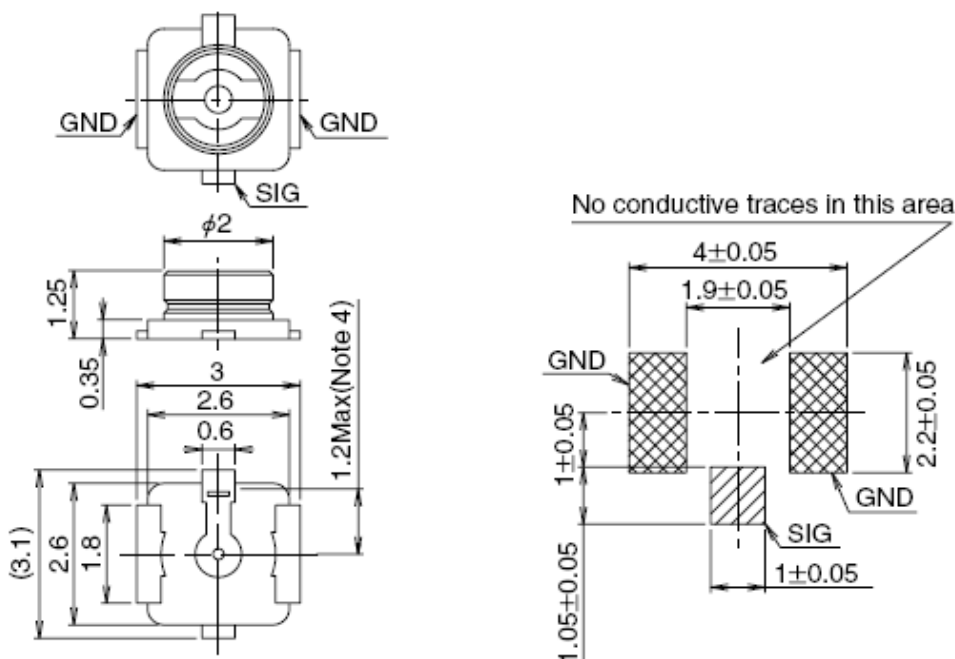

Figure 15: Dimensions of the UF.L-R-SMT Connector (Unit: mm)

U.FL-LP serial connector listed in the following figure can be used to match the UF.L-R-SMT.

Part No.	U.FL-LP-040	U.FL-LP-066	U.FL-LP(V)-040	U.FL-LP-062	U.FL-LP-088
					
Mated Height	2.5mm Max. (2.4mm Nom.)	2.5mm Max. (2.4mm Nom.)	2.0mm Max. (1.9mm Nom.)	2.4mm Max. (2.3mm Nom.)	2.4mm Max. (2.3mm Nom.)
Applicable cable	Dia. 0.81mm Coaxial cable	Dia. 1.13mm and Dia. 1.32mm Coaxial cable	Dia. 0.81mm Coaxial cable	Dia. 1mm Coaxial cable	Dia. 1.37mm Coaxial cable
Weight (mg)	53.7	59.1	34.8	45.5	71.7
RoHS	YES				

Figure 16: Mechanical Parameters of UF.L-LP Connectors

The following figure describes the space factor of mated connectors.

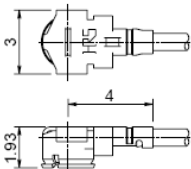
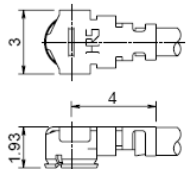
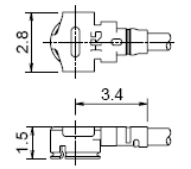
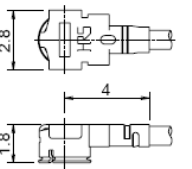
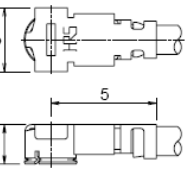
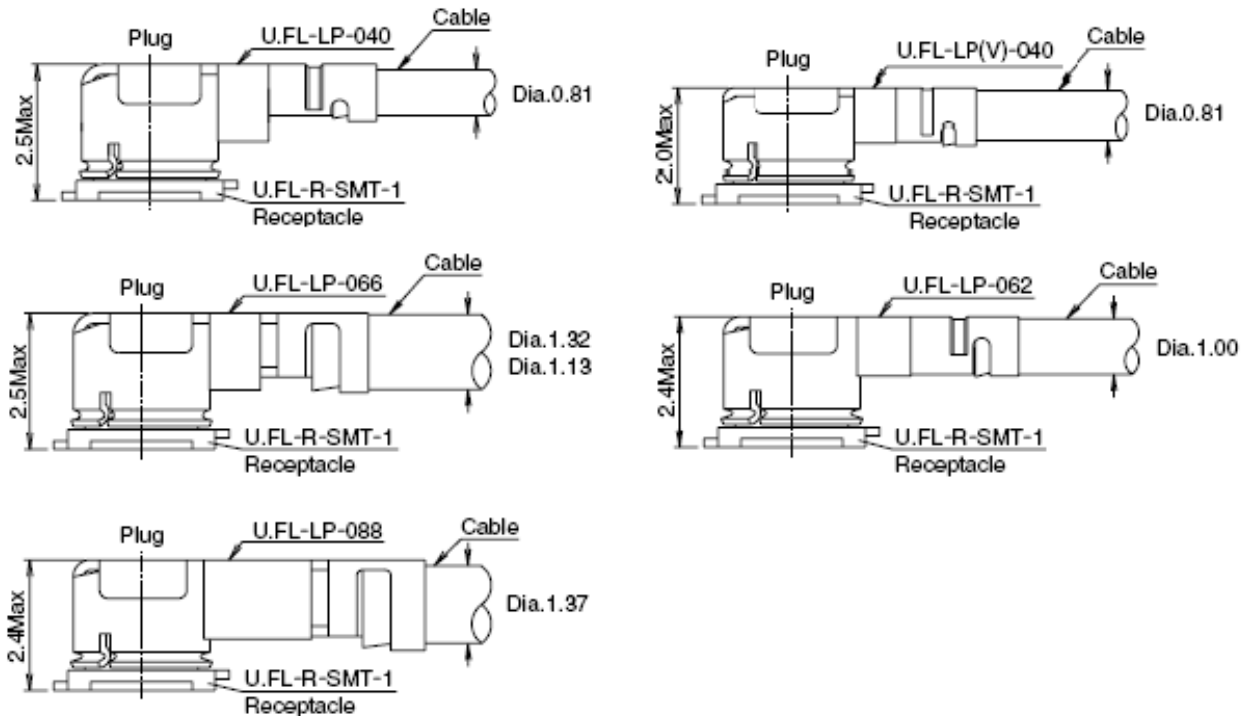

Figure 17: Space Factor of Mated Connectors (Unit: mm)

For more details, please visit <http://www.hirose.com>.

6 Electrical, Reliability and Radio Characteristics

6.1. Absolute Maximum Ratings

Absolute maximum ratings for power supply and voltage on digital and analog pins of the module are listed in the following table.

Table 8: Absolute Maximum Ratings

Parameter	Min.	Max.	Unit
VBAT	-0.5	6	V
USB_VBUS	-0.5	16	V
Voltage on Digital Pins	-0.3	2.3	V

6.2. Power Supply Ratings

Table 9: SC20-W Module Power Supply Ratings

Parameter	Description	Conditions	Min.	Typ.	Max.	Unit
VBAT	VBAT	Voltage must stay within the min/max values, including voltage drop, ripple and spikes.	3.5	3.8	4.2	V
USB_VBUS	USB detection		4.35	5.0	6.3	V
VRTC	Power supply voltage of backup battery		2.0	3.0	3.25	V

6.3. Charging Performance Specifications

Table 10: Charging Performance Specifications

Parameter	Min.	Typ.	Max.	Unit
Trickle charging-A current	81	90	99	mA
Trickle charging-A threshold voltage range (15.62mV stepping up)	2.5	2.796	2.984	V
Trickle charging-B threshold voltage range (18.75mV stepping up)	3.0	3.2	3.581	V
Charge voltage range (25mV stepping up)	4	4.2	4.775	V
Charge voltage accuracy			+/-2	%
Charge current range (90mA stepping up)	90		1440	mA
Charge current accuracy			+/-10	%
Charge termination current: when charge current is from 90 to 450mA		7		%
Charge termination current: when charge current is from 450 to 1440mA		7.4		%

6.4. Operating Temperature

The operating temperature is listed in the following table.

Table 11: Operating Temperature

Parameter	Min.	Typ.	Max.	Unit
Operating temperature range ¹⁾	-35	+25	+65	°C
Extended temperature range ²⁾	-40		+75	°C

NOTE:

- ¹⁾ Within operation temperature range, the module is IEEE compliant.
- ²⁾ Within extended temperature range, the module remains the ability for data transmission. There is no unrecoverable malfunction. There are also no effects on radio spectrum and no harm to radio

network. Only one or more parameters like Pout might reduce in their value and exceed the specified tolerances. When the temperature returns to the normal operating temperature levels, the module will meet IEEE compliant again.

6.5. Current Consumption

Table 12: SC20-W Current Consumption

Parameter	Description	Conditions	Min.	Typ.	Max.	Unit	
I _{VBAT}	OFF state	Power down		68		uA	
	Sleep state	RF sleep		1.445		mA	
	Idle state	RF idle		42.759		mA	
	Wi-Fi 11b TX		@1Mbps		298		mA
			@11Mbps		281		mA
	Wi-Fi 11g TX		@6Mbps		286		mA
			@54Mbps		188		mA
	Wi-Fi 11n TX		@6.5Mbps 20Mhz		275		mA
			@65Mbps 20Mhz		201		mA
			@13.5Mbps 40Mhz		269		mA
			@135Mbps 40Mhz		186		mA
	Wi-Fi 11b RX			120		mA	
	Wi-Fi 11g RX			119		mA	
	Wi-Fi 11n RX			117		mA	
	BT Tx Channel 0			100		mA	
	BT Tx Channel 38			100		mA	
	BT Tx Channel 78			100		mA	
	BT Rx Channel 38			80		mA	

6.6. Electrostatic Discharge

The module is not protected against electrostatic discharge (ESD) in general. Consequently, it should be subject to ESD handling precautions that are typically applied to ESD sensitive components. Proper ESD handling and packaging procedures must be applied throughout the processing, handling and operation of any application that incorporates the module.

The following table shows the electrostatic discharge characteristics of SC20-W module.

Table 13: ESD Characteristics (Temperature: 25°C, Humidity: 45%)

Tested Points	Contact Discharge	Air Discharge	Unit
VBAT, GND	+/-5	+/-10	KV
All Antenna Interfaces	+/-5	+/-10	KV
USB Interfaces	+/-2	+/-4	KV
Other Interfaces	+/-0.5	+/-1	KV

7 Mechanical Dimensions

This chapter describes the mechanical dimensions of the module. All dimensions are measured in mm.

7.1. Mechanical Dimensions of the Module

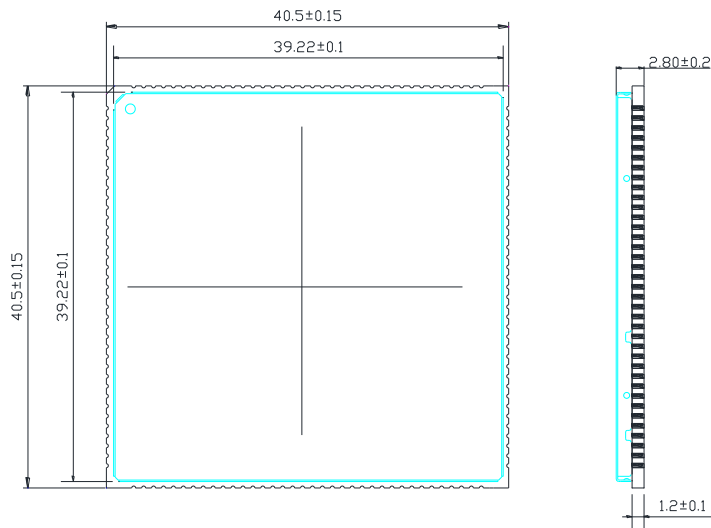

Figure 18: Module Top and Side Dimensions

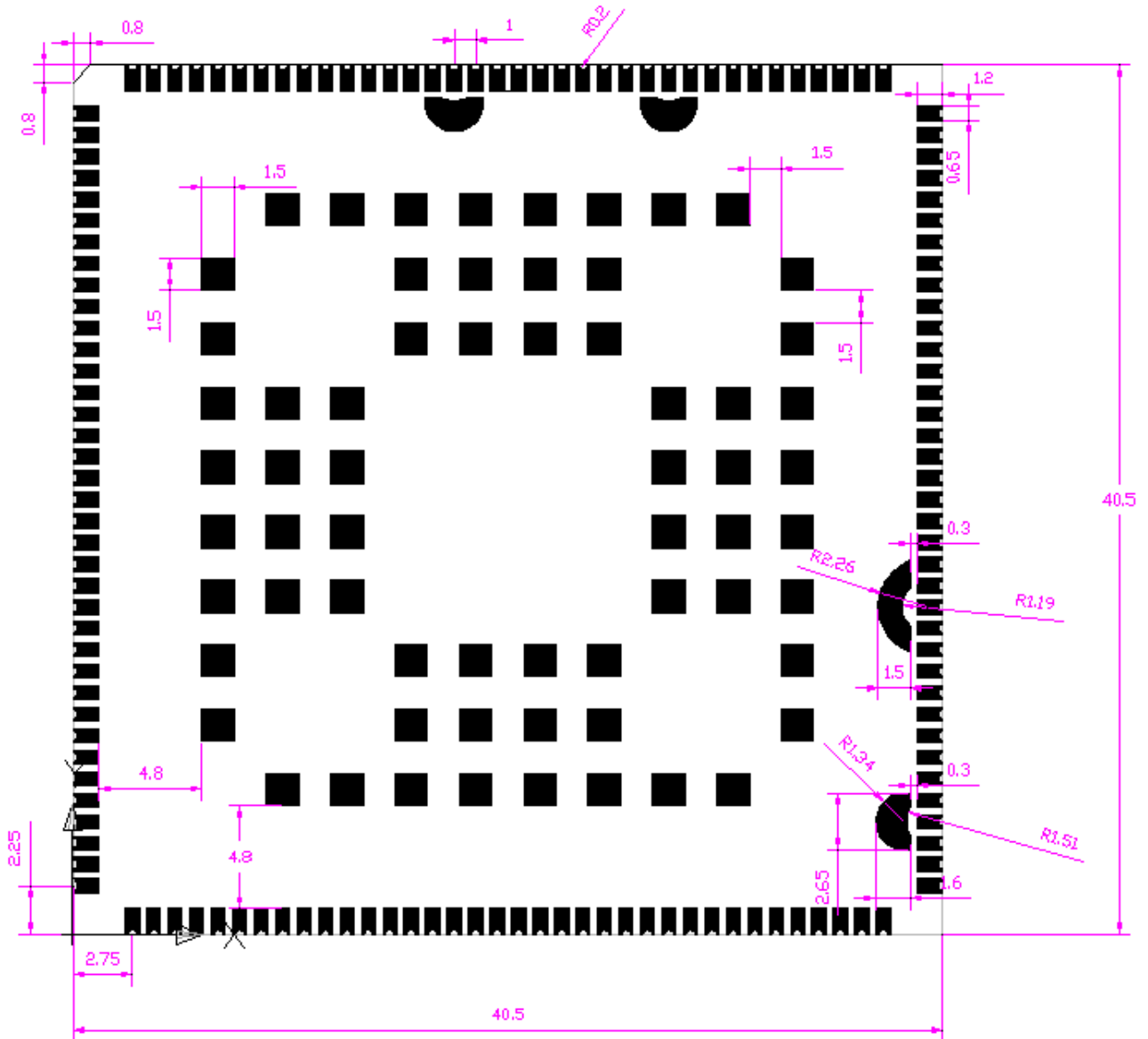

Figure 19: Module Bottom Dimensions (Top View)

7.2. Recommended Footprint

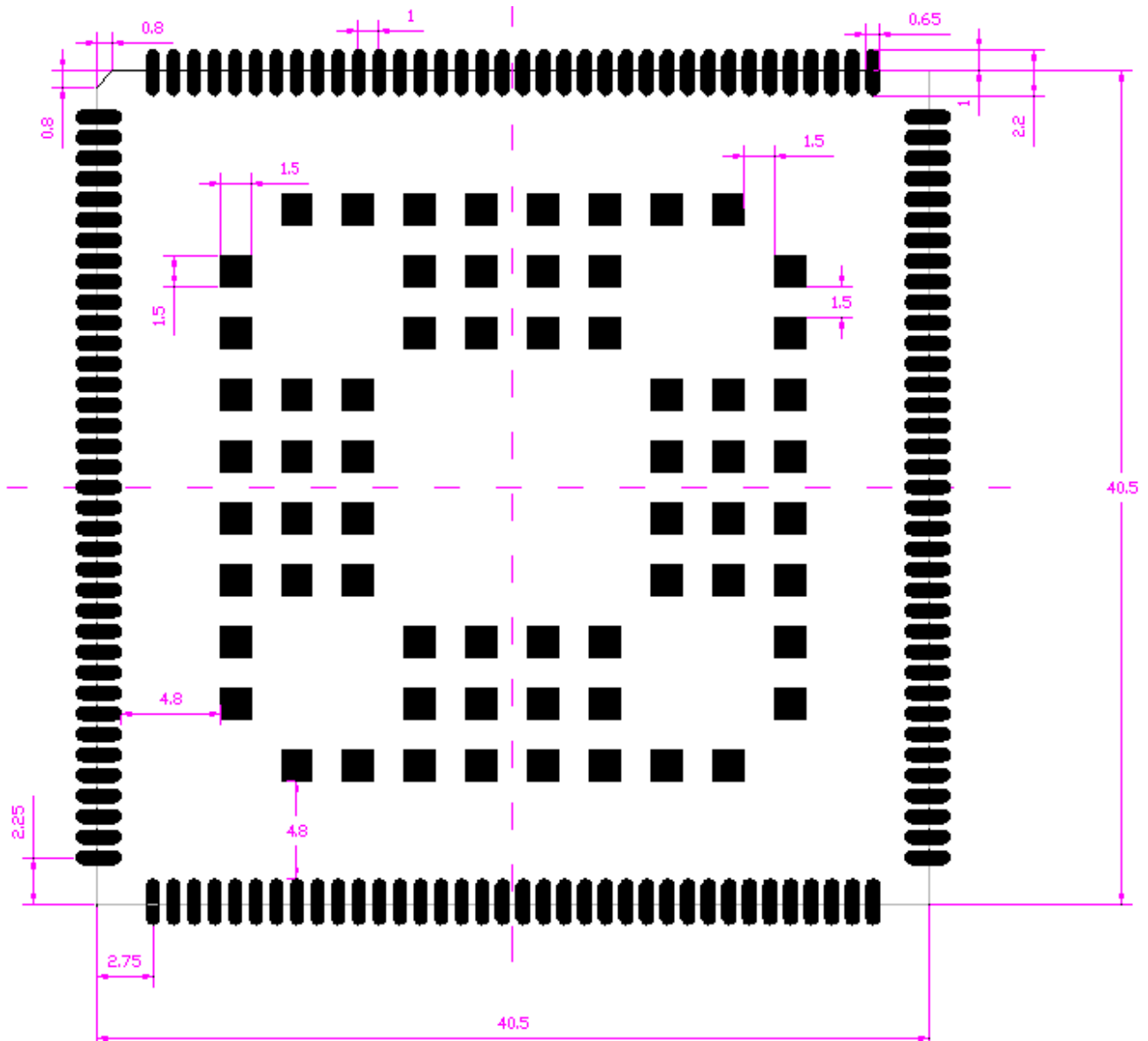

Figure 20: Recommended Footprint (Top View)

NOTE:

1. For easy maintenance of the module, keep about 3mm between the module and other components in the host PCB.
2. All RESERVED pins must NOT be connected to GND.

7.3. Top and Bottom View of the Module



Figure 21: Top View of the Module

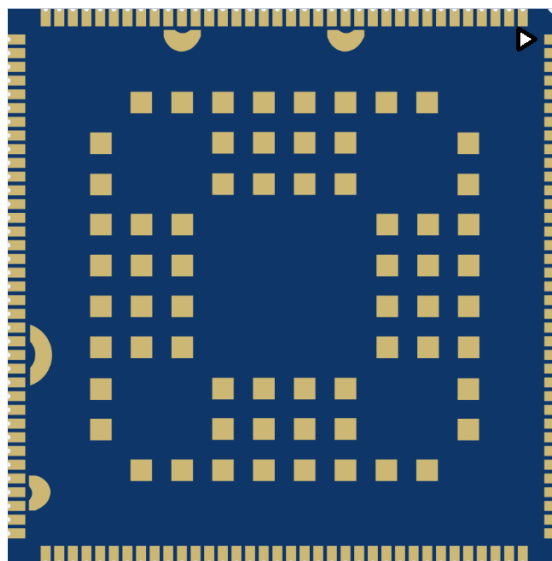

Figure 22: Bottom View of the Module

NOTE:

These are design effect drawings of SC20-W module. For more accurate pictures, please refer to the module that you get from Quectel.

8 Storage, Manufacturing and Packaging

8.1. Storage

SC20-W is stored in a vacuum-sealed bag. The storage restrictions are shown as below.

1. Shelf life in the vacuum-sealed bag: 12 months at $40^{\circ}\text{C}/90\%\text{RH}$.
2. After the vacuum-sealed bag is opened, devices that will be subjected to reflow soldering or other high temperature processes must be:
 - Mounted within 72 hours at factory conditions of $\leq 30^{\circ}\text{C}/60\%\text{RH}$.
 - Stored at $10\%\text{RH}$.
3. Devices require baking before mounting, if any circumstance below occurs.
 - Humidity indication card shows the humidity is $>10\%$ when ambient temperature is $23^{\circ}\text{C}\pm 5^{\circ}\text{C}$.
 - Mounting cannot be finished within 72 hours at factory conditions of $\leq 30^{\circ}\text{C}/60\%\text{RH}$.
4. If baking is required, devices may be baked for 48 hours at $125^{\circ}\text{C}\pm 5^{\circ}\text{C}$.

NOTE:

As the plastic package cannot be subjected to high temperature, it should be removed from devices before high temperature (125°C) baking. If shorter baking time is desired, please refer to *IPC/JEDECJ-STD-033* for baking procedure.

8.2. Manufacturing and Welding

Push the squeegee to apply the solder paste on the surface of stencil, thus making the paste fill the stencil openings and then penetrate to the PCB. The force on the squeegee should be adjusted properly so as to produce a clean stencil surface on a single pass. To ensure the module soldering quality, the thickness of stencil for the module is recommended to be 0.18mm, and the following figure is the recommended stencil design for LGA pads. For more details, please refer to **document [2]**.

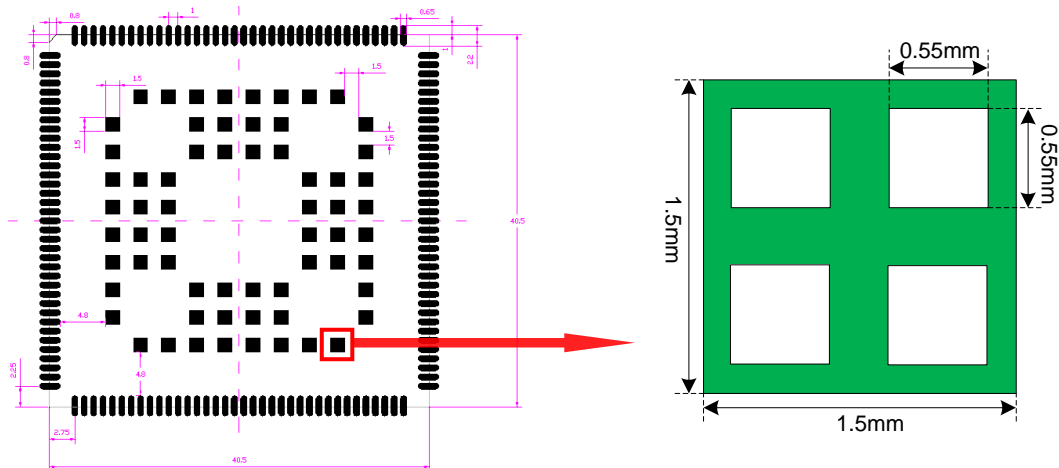

Figure 23: Recommended Stencil Design for LGA Pads

It is suggested that the peak reflow temperature is from 235 to 245°C (for SnAg3.0Cu0.5 alloy). The absolute maximum reflow temperature is 260°C. To avoid damage to the module caused by repeated heating, it is suggested that the module should be mounted after reflow soldering for the other side of PCB has been completed. Recommended reflow soldering thermal profile is shown below.

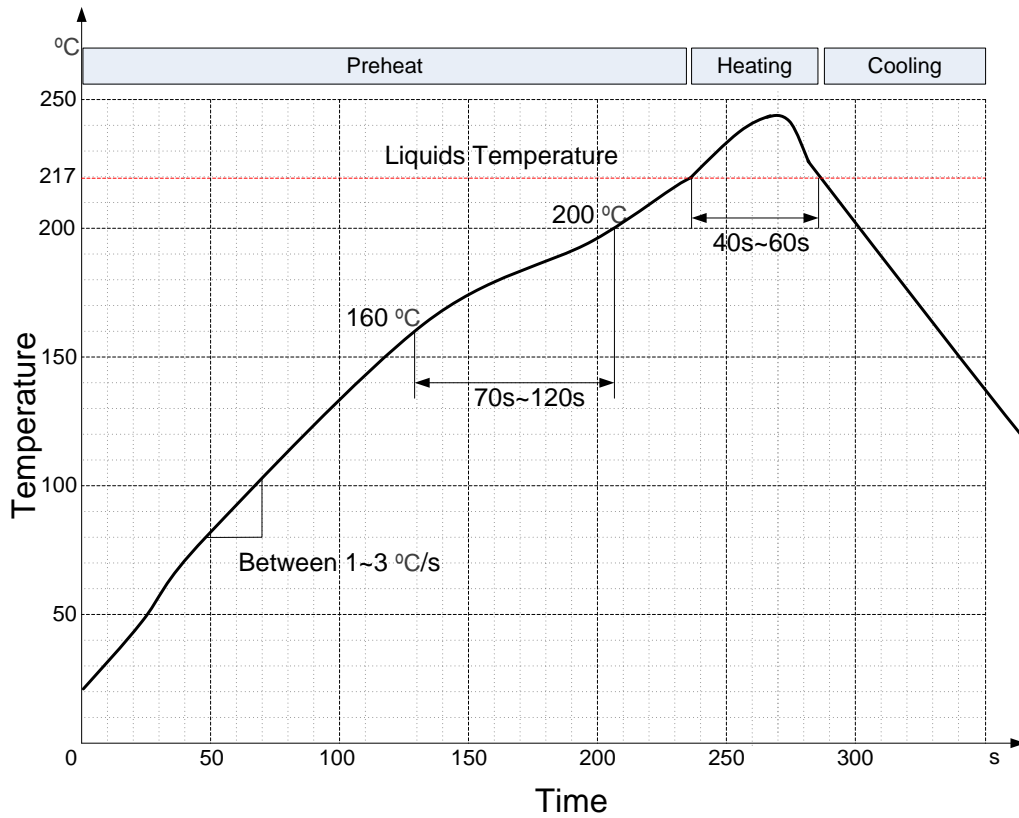

Figure 24: Reflow Soldering Thermal Profile

8.3. Packaging

SC20-W is packaged in tape and reel carriers. One reel is 12.32 meters long and contains 200pcs modules. The following figures show the package details, measured in mm.

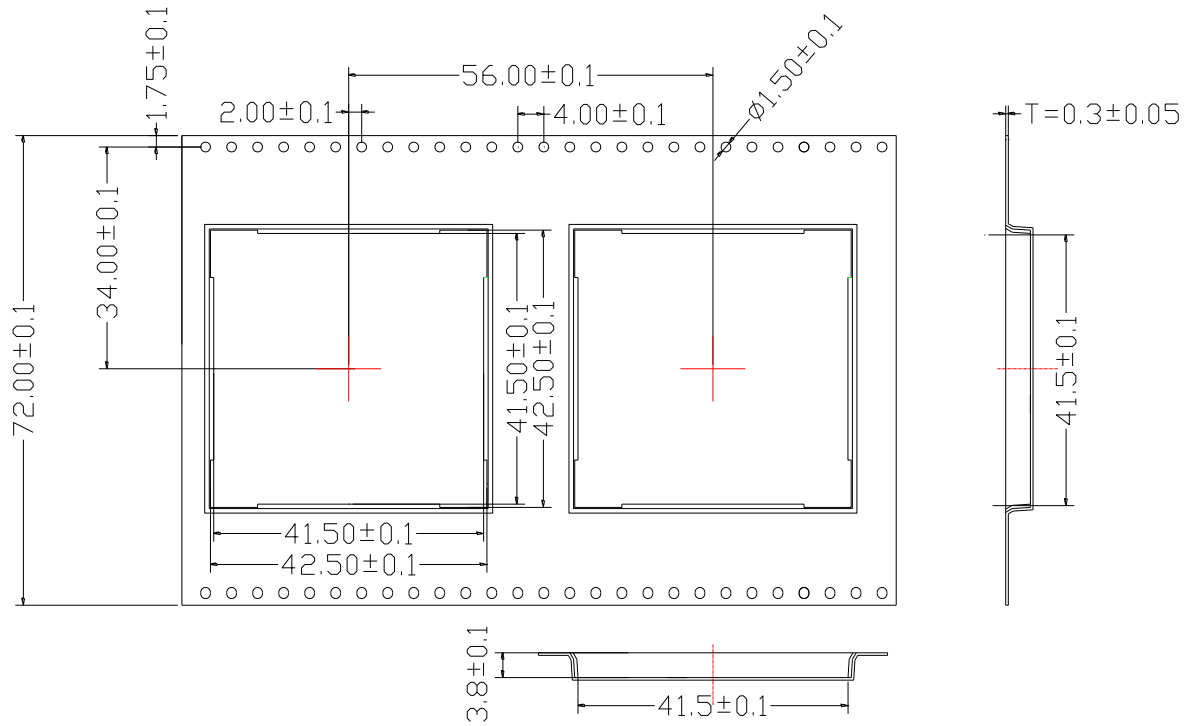

Figure 25: Tape Dimensions

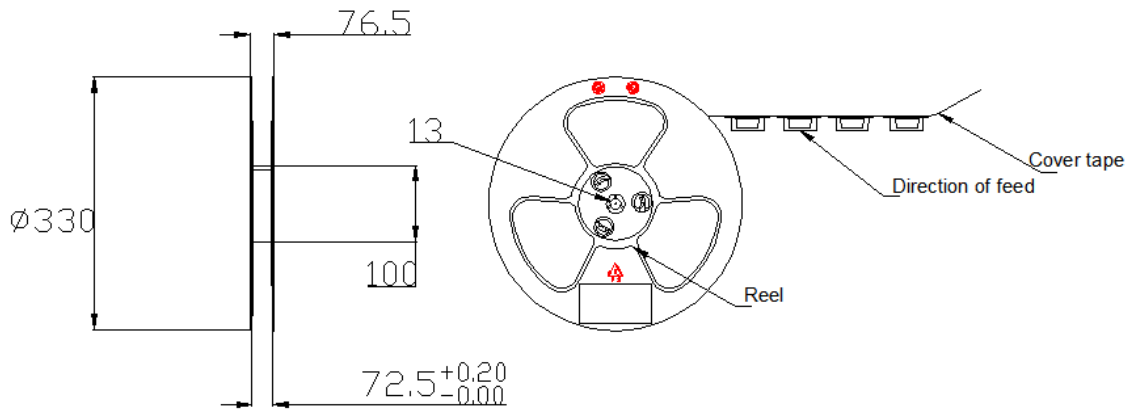

Figure 26: Reel Dimensions

Table 14: Reel Packaging

Model Name	MOQ for MP	Minimum Package: 200pcs	Minimum Package×4=800pcs
SC20-W	200	Size: 370mm × 350mm × 85mm N.W: 1.92kg G.W: 3.17kg	Size: 380mm × 365mm × 365mm N.W: 7.68kg G.W: 13.63kg

9 IC & FCC Requirement

9.1. FCC Regulations:

This device complies with part 15 of the FCC Rules. Operation is subject to the following two conditions: (1) This device may not cause harmful interference, and (2) This device must accept any interference received, including interference that may cause undesired operation.

This device has been tested and found to comply with the limits for a Class B digital device, pursuant to Part 15 of the FCC Rules. These limits are designed to provide reasonable protection against harmful interference in a residential installation. This equipment generates, uses and can radiate radio frequency energy and, if not installed and used in accordance with the instructions, may cause harmful interference to radio communications. However, there is no guarantee that interference will not occur in a particular installation. If this equipment does cause harmful interference to radio or television reception, which can be determined by turning the equipment off and on, the user is encouraged to try to correct the interference by one or more of the following measures:

- Reorient or relocate the receiving antenna.
- Increase the separation between the equipment and receiver.
- Connect the equipment into an outlet on a circuit different from that to which the receiver is connected.
- Consult the dealer or an experienced radio/TV technician for help.

Caution: Changes or modifications not expressly approved by the party responsible for compliance could void the user's authority to operate the equipment.

9.2. RF Exposure Information

This device complies with FCC radiation exposure limits set forth for an uncontrolled environment. In order to avoid the possibility of exceeding the FCC radio frequency exposure limits, human proximity to the antenna shall not be less than 20cm (8 inches) during normal operation.

9.3. ISED Notice

This device complies with Innovation, Science and Economic Development Canada license-exempt RSS standard(s). Operation is subject to the following two conditions:

- (1) this device may not cause interference, and
- (2) this device must accept any interference, including interference that may cause undesired operation of the device.

Le présent appareil est conforme aux CNR Innovation, Sciences et Développement économique Canada applicables aux appareils radio exempts de licence. L'exploitation est autorisée aux deux conditions suivantes:

- (1) l'appareil ne doit pas produire de brouillage, et
- (2) l'utilisateur de l'appareil doit accepter tout brouillage radioélectrique subi, même si le brouillage est susceptible d'en

This Class B digital apparatus complies with Canadian ICES-003.

Cet appareil numérique de la classe B est conforme à la norme NMB-003 du Canada.

9.4. ISED Radiation Exposure Statement

This device complies with RSS-102 radiation exposure limits set forth for an uncontrolled environment. In order to avoid the possibility of exceeding the ISED radio frequency exposure limits, human proximity to the antenna shall not be less than 20cm (8 inches) during normal operation.

Cet appareil est conforme aux limites d'exposition aux rayonnements de la CNR-102 définies pour un environnement non contrôlé. Afin d'éviter la possibilité de dépasser les limites d'exposition aux fréquences radio de la CNR-102, la proximité humaine à l'antenne ne doit pas être inférieure à 20 cm (8 pouces) pendant le fonctionnement normal.

9.5. IMPORTANT NOTE:

This module is intended for OEM integrator. The OEM integrator is still responsible for the FCC compliance requirement of the end product, which integrates this module. 20cm minimum distance has to be able to be maintained between the antenna and the users for the host this module is integrated into. Under such configuration, the FCC radiation exposure limits set forth for an population/uncontrolled environment can be satisfied.

Any changes or modifications not expressly approved by the manufacturer could void the user's authority to operate this equipment.

9.6. USERS MANUAL OF THE END PRODUCT:

In the users manual of the end product, the end user has to be informed to keep at least 20cm separation with the antenna while this end product is installed and operated. The end user has to be informed that the FCC radio-frequency exposure guidelines for an uncontrolled environment can be satisfied. The end user has to also be informed that any changes or modifications not expressly approved by the manufacturer could void the user's authority to operate this equipment. If the size of the end product is smaller than 8x10cm, then additional FCC part 15.19 statement is required to be available in the users manual: This device complies with Part 15 of FCC rules. Operation is subject to

the following two conditions: (1) this device may not cause harmful interference and (2) this device must accept any interference received, including interference that may cause undesired operation.

9.7. LABEL OF THE END PRODUCT:

The final end product must be labeled in a visible area with the following " Contains Transmitter Module FCC ID: XMR201709SC20W". If the size of the end product is larger than 8x10cm, then the following FCC part 15.19 statement has to also be available on the label: This device complies with Part 15 of FCC rules.

Operation is subject to the following two conditions: (1) this device may not cause harmful interference and (2) this device must accept any interference received, including interference that may cause undesired operation.

The Innovation, Science and Economic Development Canada certification label of a module shall be clearly visible at all times when installed in the host device; otherwise, the host device must be labeled to display the Innovation, Science and Economic Development Canada certification number for the module, preceded by the words "Contains transmitter module IC: 10224A-201709SC20W".

The device is going on be operated in 5150~5250 frequency range. It is restricted indoor environment only in Canada.

1、 The characteristic impedance depends on the dielectric of PCB, the trace width and the grand plane spacing, Coated Coplanar Line is required. The detail simulation as below.

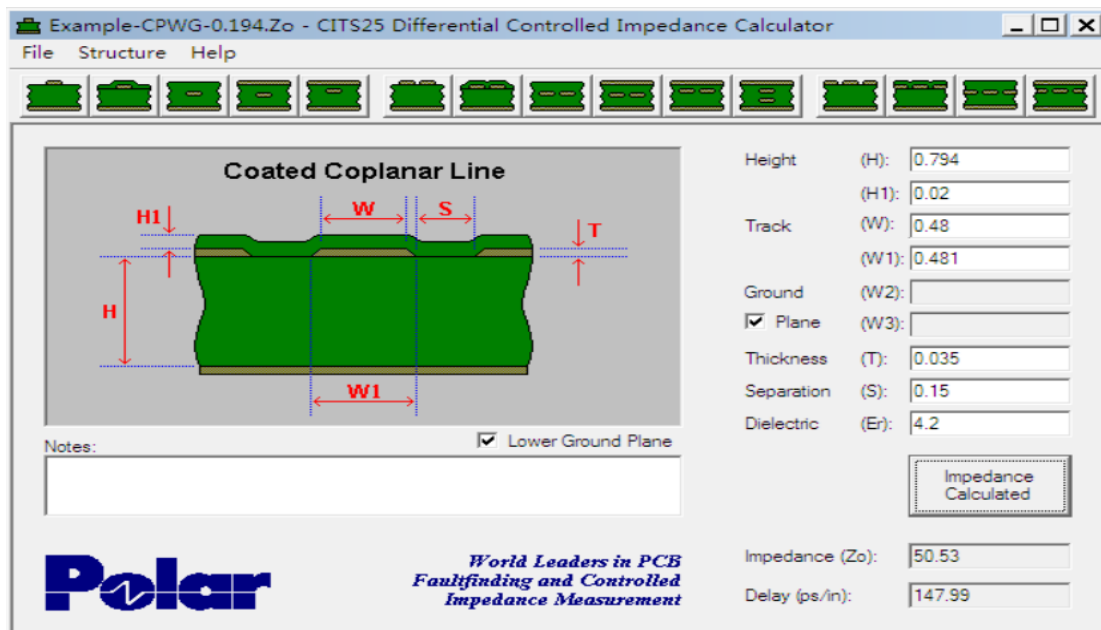

2、 the RF trace of the test board which was used in the FCC test is defined as below.

