

# BC95-D

# Hardware Design Datasheet

## NB-IoT Module Series

Rev. BC95-D\_Hardware\_Design\_Datasheet\_V1.3

Date: 2018-06-08

Status: Released



**Our aim is to provide customers with timely and comprehensive service. For any assistance, please contact our company headquarters:**

**Quectel Wireless Solutions Co., Ltd.**

7<sup>th</sup> Floor, Hongye Building, No.1801 Hongmei Road, Xuhui District, Shanghai 200233, China

Tel: +86 21 5108 6236

Email: [info@quectel.com](mailto:info@quectel.com)

**Or our local office. For more information, please visit:**

<http://quectel.com/support/sales.htm>

**For technical support, or to report documentation errors, please visit:**

<http://quectel.com/support/technical.htm>

Or email to: [support@quectel.com](mailto:support@quectel.com)

**GENERAL NOTES**

QUECTEL OFFERS THE INFORMATION AS A SERVICE TO ITS CUSTOMERS. THE INFORMATION PROVIDED IS BASED UPON CUSTOMERS' REQUIREMENTS. QUECTEL MAKES EVERY EFFORT TO ENSURE THE QUALITY OF THE INFORMATION IT MAKES AVAILABLE. QUECTEL DOES NOT MAKE ANY WARRANTY AS TO THE INFORMATION CONTAINED HEREIN, AND DOES NOT ACCEPT ANY LIABILITY FOR ANY INJURY, LOSS OR DAMAGE OF ANY KIND INCURRED BY USE OF OR RELIANCE UPON THE INFORMATION. ALL INFORMATION SUPPLIED HEREIN IS SUBJECT TO CHANGE WITHOUT PRIOR NOTICE.

**COPYRIGHT**

THE INFORMATION CONTAINED HERE IS PROPRIETARY TECHNICAL INFORMATION OF QUECTEL WIRELESS SOLUTIONS CO., LTD. TRANSMITTING, REPRODUCTION, DISSEMINATION AND EDITING OF THIS DOCUMENT AS WELL AS UTILIZATION OF THE CONTENT ARE FORBIDDEN WITHOUT PERMISSION. OFFENDERS WILL BE HELD LIABLE FOR PAYMENT OF DAMAGES. ALL RIGHTS ARE RESERVED IN THE EVENT OF A PATENT GRANT OR REGISTRATION OF A UTILITY MODEL OR DESIGN.

***Copyright © Quectel Wireless Solutions Co., Ltd. 2018. All rights reserved.***

# About the Document

## History

Revision	Date	Author	Description
1.0	2018-05-03	Ewent LU	Initial
1.1	2018-05-25	Ewent LU	1. Added chip name in Chapter 2.3. 2. Added reference chip datasheet in Table 29.
1.2	2018-06-05	Beny ZHU	Updated the note about RF receiving sensitivity test condition in Chapter 4.4.
1.3	2018-06-08	Ewent LU	Added “Quectel_BC95-D_Reference_Design” document as a reference datasheet in Table 29.

## Contents

About the Document.....	2
Contents.....	3
Table Index.....	5
Figure Index.....	6
<b>1 Introduction .....</b>	<b>7</b>
1.1. Safety Information .....	8
<b>2 Product Concept.....</b>	<b>9</b>
2.1. General Description.....	9
2.2. Key Features .....	9
2.3. Functional Diagram .....	11
2.4. Evaluation Board .....	11
<b>3 Application Functions .....</b>	<b>12</b>
3.1. General Description.....	12
3.2. Pin Assignment.....	13
3.3. Pin Description .....	14
3.4. Operating Modes.....	18
3.5. Power Supply .....	19
3.5.1. Power Supply Pins.....	19
3.5.2. Reference Design for Power Supply.....	19
3.6. Turn on and off Scenarios .....	20
3.6.1. Turn on .....	20
3.6.2. Turn off .....	21
3.6.3. Reset the Module .....	21
3.7. Power Saving Mode (PSM).....	22
3.8. UART Interfaces .....	23
3.8.1. Main Port .....	25
3.8.2. Debug Port .....	26
3.8.3. UART Application .....	26
3.9. USIM Interface.....	27
3.10. ADC Interface .....	29
3.11. DAC Interface .....	30
3.12. SPI Interface.....	31
3.13. I2C Interface .....	31
3.14. Behaviors of RI.....	32
3.15. Network Status Indication.....	33
<b>4 Antenna Interface.....</b>	<b>34</b>
4.1. RF Antenna Reference Design .....	34
4.2. Reference Design of RF Layout.....	35
4.3. RF Output Power.....	37

4.4.	RF Receiving Sensitivity.....	37
4.5.	Operating Frequencies.....	37
4.6.	Antenna Requirement .....	38
4.7.	Recommended RF Connector for Antenna Installation .....	38
<b>5</b>	<b>Electrical, Reliability and Radio Characteristics .....</b>	<b>39</b>
5.1.	Absolute Maximum Ratings.....	39
5.2.	Operation and Storage Temperatures.....	39
5.3.	Current Consumption .....	40
5.4.	Electrostatic Discharge.....	40
<b>6</b>	<b>Mechanical Dimensions .....</b>	<b>42</b>
6.1.	Mechanical Dimensions of the Module .....	42
6.2.	Recommended Footprint.....	44
6.3.	Design Effect Drawings of the Module .....	45
<b>7</b>	<b>Storage, Manufacturing and Packaging .....</b>	<b>46</b>
7.1.	Storage .....	46
7.2.	Manufacturing and Soldering .....	47
7.3.	Packaging.....	48
7.3.1.	Tape and Reel Packaging .....	48
<b>8</b>	<b>Appendix A References.....</b>	<b>50</b>

## Table Index

TABLE 1: FREQUENCY OF BC95-D MODULE .....	9
TABLE 2: BC95-D KEY FEATURES .....	10
TABLE 3: I/O PARAMETERS DEFINITION .....	14
TABLE 4: PIN DESCRIPTION .....	14
TABLE 5: OVERVIEW OF OPERATING MODES .....	19
TABLE 6: VBAT AND GND PINS .....	19
TABLE 7: RESET CHARACTERISTICS .....	21
TABLE 8: PIN DEFINITION OF THE UART INTERFACES .....	24
TABLE 9: LOGIC LEVELS OF THE UART INTERFACES .....	24
TABLE 10: UART AND LPUART SETTINGS .....	25
TABLE 11: PIN DEFINITION OF THE USIM INTERFACE .....	28
TABLE 12: PIN DEFINITION OF THE ADC .....	29
TABLE 13: CHARACTERISTICS OF THE ADC .....	29
TABLE 14: PIN DEFINITION OF THE DAC .....	30
TABLE 15: CHARACTERISTICS OF THE DAC .....	30
TABLE 16: PIN DEFINITION OF THE SPI .....	31
TABLE 17: PIN DEFINITION OF THE I2C .....	31
TABLE 18: BEHAVIORS OF RI .....	32
TABLE 19: WORKING STATE OF NETLIGHT .....	33
TABLE 20: PIN DEFINITION OF THE RF ANTENNA INTERFACE .....	34
TABLE 21: RF OUTPUT POWER (UPLINK QPSK AND BPSK MODULATION) .....	37
TABLE 22: RF RECEIVING SENSITIVITY (THROUGHPUT ≥ 95%) .....	37
TABLE 23: OPERATING FREQUENCIES .....	37
TABLE 24: ANTENNA REQUIREMENT .....	38
TABLE 25: ABSOLUTE MAXIMUM RATINGS .....	39
TABLE 26: OPERATION AND STORAGE TEMPERATURES .....	39
TABLE 27: CURRENT CONSUMPTION .....	40
TABLE 28: ELECTROSTATIC DISCHARGE CHARACTERISTICS .....	41
TABLE 29: RELATED DOCUMENTS .....	50
TABLE 30: TERMS AND ABBREVIATIONS .....	50

## Figure Index

FIGURE 1: FUNCTIONAL DIAGRAM.....	11
FIGURE 2: PIN ASSIGNMENT .....	13
FIGURE 3: REFERENCE CIRCUIT FOR POWER SUPPLY .....	20
FIGURE 4: TURN-ON TIMING .....	20
FIGURE 5: TURN-OFF TIMING.....	21
FIGURE 6: REFERENCE CIRCUIT OF RESET BY USING DRIVING CIRCUIT .....	22
FIGURE 7: REFERENCE CIRCUIT OF RESET BY USING BUTTON .....	22
FIGURE 8: MODULE POWER CONSUMPTION IN DIFFERENT MODES.....	23
FIGURE 9: REFERENCE DESIGN FOR MAIN PORT.....	25
FIGURE 10: REFERENCE DESIGN FOR DEBUG PORT.....	26
FIGURE 11: LEVEL MATCH DESIGN FOR 3.3V SYSTEM .....	26
FIGURE 12: SKETCH MAP FOR RS-232 INTERFACE MATCH .....	27
FIGURE 13: REFERENCE CIRCUIT FOR USIM INTERFACE WITH 6-PIN USIM CARD CONNECTOR .....	28
FIGURE 14: BEHAVIORS OF RI WHEN A URC OR SMS MESSAGE IS RECEIVED.....	32
FIGURE 15: REFERENCE DESIGN FOR NETLIGHT.....	33
FIGURE 16: REFERENCE DESIGN FOR RF ANTENNA.....	34
FIGURE 17: MICROSTRIP LINE DESIGN ON A 2-LAYER PCB .....	35
FIGURE 18: COPLANAR WAVEGUIDE LINE DESIGN ON A 2-LAYER PCB.....	35
FIGURE 19: COPLANAR WAVEGUIDE LINE DESIGN ON A 4-LAYER PCB (LAYER 3 AS REFERENCE GROUND) .....	36
FIGURE 20: COPLANAR WAVEGUIDE LINE DESIGN ON A 4-LAYER PCB (LAYER 4 AS REFERENCE GROUND) .....	36
FIGURE 21: MODULE TOP AND SIDE DIMENSIONS .....	42
FIGURE 22: MODULE BOTTOM DIMENSIONS (BOTTOM VIEW) .....	43
FIGURE 23: RECOMMENDED FOOTPRINT (TOP VIEW) .....	44
FIGURE 24: TOP VIEW OF THE MODULE .....	45
FIGURE 25: BOTTOM VIEW OF THE MODULE .....	45
FIGURE 26: REFLOW SOLDERING THERMAL PROFILE .....	47
FIGURE 27: TAPE DIMENSIONS.....	48
FIGURE 28: REEL DIMENSIONS .....	49

# 1 Introduction

This document defines the BC95-D module and describes its air interface and hardware interface which are connected with customers' applications.

This document can help customers to quickly understand module interface specifications, electrical and mechanical details, as well as other related information of the module. Associated with application note and user guide, customers can use the BC95-D module to design and set up mobile applications easily.



## 1.1. Safety Information

The following safety precautions must be observed during all phases of the operation, such as usage, service or repair of any cellular terminal or mobile incorporating BC95-D module. Manufacturers of the cellular terminal should send the following safety information to users and operating personnel, and incorporate these guidelines into all manuals supplied with the product. If not so, Quectel assumes no liability for the customers' failure to comply with these precautions.



Full attention must be given to driving at all times in order to reduce the risk of an accident. Using a mobile while driving (even with a handsfree kit) causes distraction and can lead to an accident. You must comply with laws and regulations restricting the use of wireless devices while driving.



Switch off the cellular terminal or mobile before boarding an aircraft. Make sure it is switched off. The operation of wireless appliances in an aircraft is forbidden, so as to prevent interference with communication systems. Consult the airline staff about the use of wireless devices on boarding the aircraft, if your device offers an Airplane Mode which must be enabled prior to boarding an aircraft.



Switch off your wireless device when in hospitals, clinics or other health care facilities. These requests are designed to prevent possible interference with sensitive medical equipment.



Cellular terminals or mobiles operating over radio frequency signal and cellular network cannot be guaranteed to connect in all conditions, for example no mobile fee or with an invalid (U)SIM card. While you are in this condition and need emergent help, please remember using emergency call. In order to make or receive a call, the cellular terminal or mobile must be switched on and in a service area with adequate cellular signal strength.



Your cellular terminal or mobile contains a transmitter and receiver. When it is ON, it receives and transmits radio frequency energy. RF interference can occur if it is used close to TV set, radio, computer or other electric equipment.



In locations with potentially explosive atmospheres, obey all posted signs to turn off wireless devices such as your phone or other cellular terminals. Areas with potentially explosive atmospheres include fuelling areas, below decks on boats, fuel or chemical transfer or storage facilities, areas where the air contains chemicals or particles such as grain, dust or metal powders, etc.

# 2 Product Concept

## 2.1. General Description

BC95-D is a high-performance NB-IoT module with low power consumption. It supports two frequency bands as illustrated in the table below. The module is designed to communicate with mobile network operators' infrastructure equipment through the NB-IoT radio protocol (3GPP Rel.14).

**Table 1: Frequency of BC95-D Module**

Frequency Bands	Transmit	Receive
B111	1915MHz~1920MHz	722MHz~728MHz
B222	1915MHz~1920MHz	1995MHz~2020MHz

BC95-D is an SMD type module with LCC package, and comes with an ultra-compact profile of 23.6mm × 19.9mm × 2.2mm, making it can be easily embedded into applications. It provides hardware interfaces such as UART interfaces, and can meet almost all the requirements for IoT applications, such as smart metering, bike sharing, smart parking, smart city, security and asset tracking, home appliances, agricultural and environmental monitoring, etc.

Designed with power saving technique, the BC95-D consumes an ultra-low current of 5uA in PSM (Power Saving Mode).

The module fully complies with the RoHS directive of the European Union.

## 2.2. Key Features

The following table describes the detailed features of BC95-D module.

**Table 2: BC95-D Key Features**

Feature	Details
Power Supply	<ul style="list-style-type: none"> <li>● Supply voltage: 3.1V~4.2V</li> <li>● Typical supply voltage: 3.6V</li> </ul>
Power Saving Mode	<ul style="list-style-type: none"> <li>● Maximum power consumption in PSM: 15uW</li> </ul>
Transmitting Power	<ul style="list-style-type: none"> <li>● 23dBm±2dB</li> </ul>
Temperature Range	<ul style="list-style-type: none"> <li>● Operation temperature range: -40°C ~ +85°C <sup>1)</sup></li> <li>● Storage temperature range: -40°C ~ +90°C</li> </ul>
USIM Interface	<ul style="list-style-type: none"> <li>● Supports Class B USIM card: 1.8V/3.0V</li> </ul>
UART Interfaces	<p><b>Main port:</b></p> <ul style="list-style-type: none"> <li>● When used for AT command communication and data transmission, the baud rate supports 4800bps, 9600bps and 115200bps, and the default baud rate is 9600bps</li> <li>● When used for firmware upgrading, the baud rate is 921600bps</li> </ul> <p><b>Debug port:</b></p> <ul style="list-style-type: none"> <li>● Used for firmware debugging</li> <li>● Only supports 921600bps baud rate</li> </ul> <p><b>UART3:</b></p> <ul style="list-style-type: none"> <li>● Used for communication with peripheral</li> </ul>
Internet Protocol Features	<ul style="list-style-type: none"> <li>● Supports IPv4/IPv6/UDP/Non-IP/TCP</li> </ul>
SMS	<ul style="list-style-type: none"> <li>● Text and PDU mode</li> <li>● Point to point MO and MT</li> </ul>
Data Transmission Feature	<ul style="list-style-type: none"> <li>● Single tone with 15kHz/3.75kHz subcarrier: 25.2kbps (DL)/15.625kbps (UL)</li> <li>● Multi tone with 15kHz subcarrier: 25.2kbps (DL)/54kbps (UL)</li> </ul>
AT Commands	<ul style="list-style-type: none"> <li>● Compliant with 3GPP TS 27.007 V14.3.0 (2017-03) and Quectel AT commands</li> </ul>
Physical Characteristics	<ul style="list-style-type: none"> <li>● Size: (23.6±0.15) mm × (19.9±0.15) mm × (2.2±0.2) mm</li> <li>● Weight: 1.8g±0.2g</li> </ul>
Firmware Upgrade	<ul style="list-style-type: none"> <li>● Firmware upgrade via UART</li> </ul>
Antenna Interface	<ul style="list-style-type: none"> <li>● 50Ω impedance control</li> </ul>
RoHS	<ul style="list-style-type: none"> <li>● All hardware components are fully compliant with EU RoHS directive</li> </ul>

**NOTE**

<sup>1)</sup> Within operation temperature range, the module is 3GPP compliant.

## 2.3. Functional Diagram

The following figure shows a block diagram of BC95-D and illustrates the major functional parts.

- Radio frequency
- Baseband
- Power management
- Peripheral interfaces

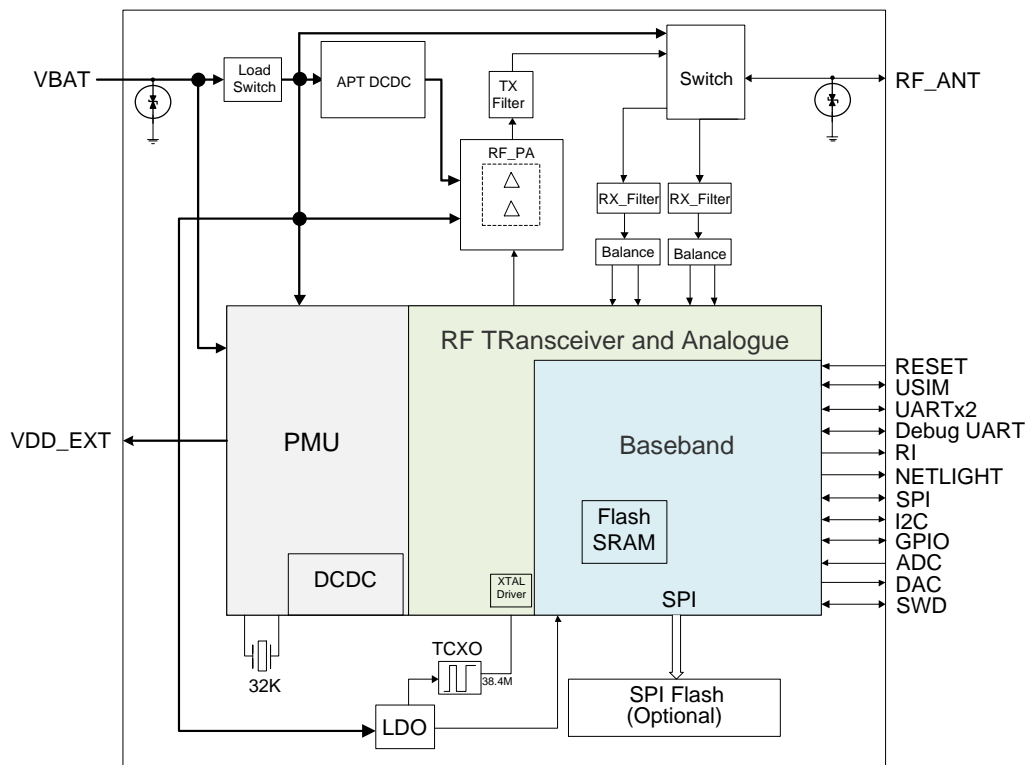

Figure 1: Functional Diagram

### NOTE

PA model: SKY77761.

Baseband chip: Hi2115GBCV110.

## 2.4. Evaluation Board

In order to help customers develop applications with BC95-D, Quectel supplies the evaluation board (EVB), USB cable, antenna and other peripherals to control or test the module.

# 3 Application Functions

## 3.1. General Description

BC95-D is equipped with 54 LCC pads (with 1.1mm pitch) and 40 LGA pads (with 1.7mm pitch). The following chapters provide detailed descriptions of these pins:

- Power supply
- UART interfaces
- USIM interface
- ADC interface
- DAC interface
- SPI interface
- I2C interface
- Network status indication
- RF interface

### 3.2. Pin Assignment

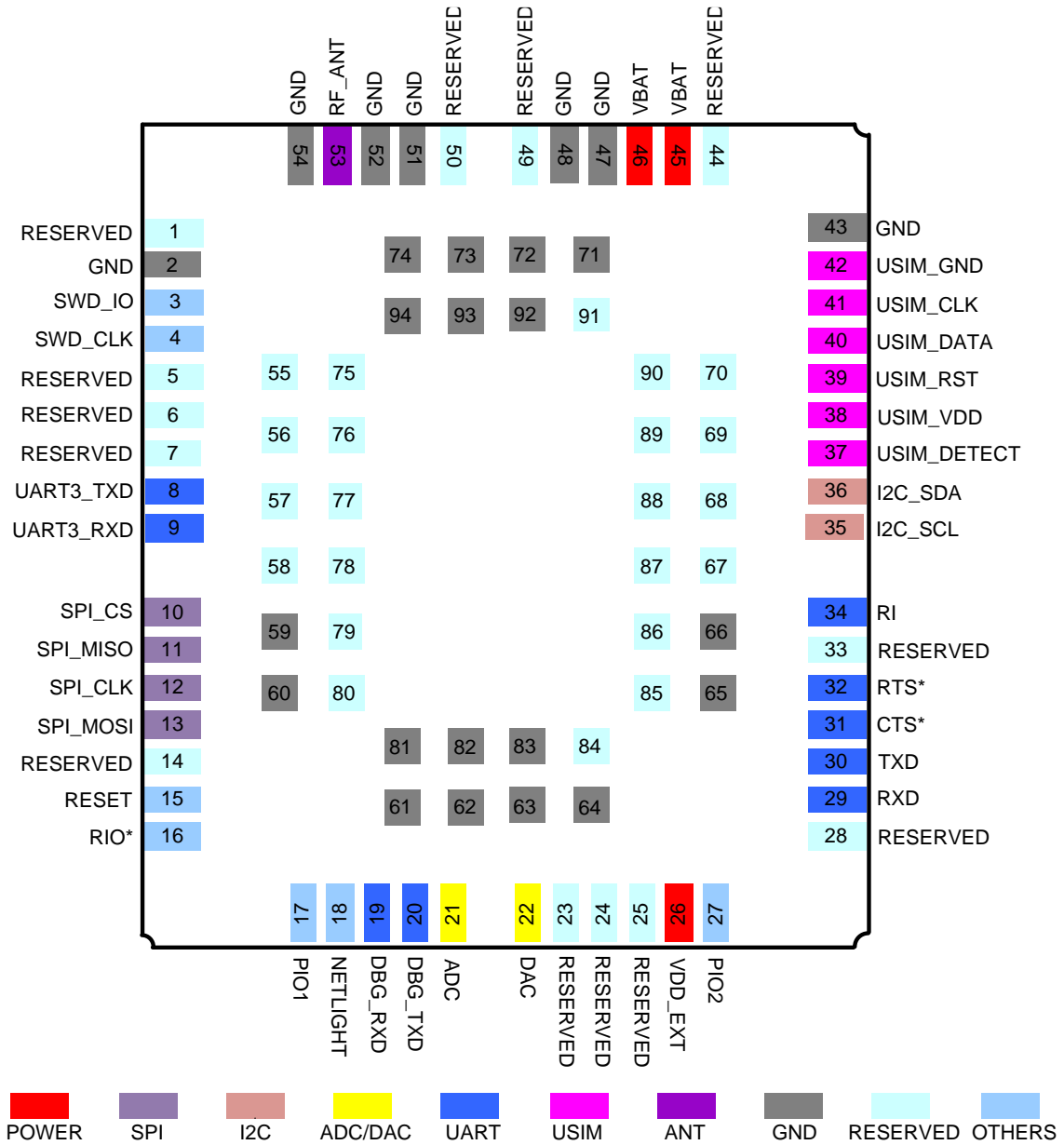

Figure 2: Pin Assignment

#### NOTES

1. Keep all reserved pins unconnected.
2. “\*” means under development.

### 3.3. Pin Description

The following tables show the pin definition and description of BC95-D.

**Table 3: I/O Parameters Definition**

Type	Description
IO	Bidirectional
DI	Digital input
DO	Digital output
PI	Power input
PO	Power output
AI	Analog input
AO	Analog output
OD	Open drain

**Table 4: Pin Description**

Power Supply					
Pin Name	Pin No.	I/O	Description	DC Characteristics	Comment
VBAT	45, 46	PI	Main power supply of the module: VBAT=3.1V~4.2V	Vmax=4.2V Vmin=3.1V Vnorm=3.6V	The power supply must be able to provide sufficient current up to 0.8A.
VDD_EXT	26	PO	Supply 3.0V voltage for external circuits	Vmax=3.3V Vmin=2.7V Vnorm=3V Iomax=20mA	If it is used for power supply, a 2.2uF~4.7uF bypass capacitor is recommended to be added in active and idle modes. In PSM, it cannot be used for

power supply.  
If unused, keep  
this pin open.

GND	2, 43, 47, 48, 51, 52, 54, 59~66, 71~74, 81~83, 92~94	Ground
-----	---	--------

#### Reset Interface

Pin Name	Pin No.	I/O	Description	DC Characteristics	Comment
RESET	15	DI	Reset the module	$R_{PU} \approx 78k\Omega$ $V_{IHmax} = 3.3V$ $V_{IHmin} = 2.1V$ $V_{ILmax} = 0.6V$	Pull up internally. Active low.

#### Network Status Indicator

Pin Name	Pin No.	I/O	Description	DC Characteristics	Comment
NETLIGHT	18	DO	Network status indication	$V_{OLmax} = 0.3V$ $V_{OHmin} = 2.4V$	If unused, keep this pin open.

#### Analog Interface

Pin Name	Pin No.	I/O	Description	DC Characteristics	Comment
ADC	21	AI	General purpose analog to digital converter interface	Input voltage range: 0V~4.0V	The maximum input voltage should be lower than the VBAT voltage. If unused, keep this pin open. Minimum input impedance: 100M $\Omega$
DAC	22	AO	General purpose digital to analog converter interface	Output voltage range: Type: 3.5mV	If unused, keep this pin open.

#### Main UART Port

Pin Name	Pin No.	I/O	Description	DC Characteristics	Comment
----------	---------	-----	-------------	--------------------	---------



RXD	29	DI	Receive data	$V_{ILmax}=0.6V$ $V_{IHmin}=2.1V$ $V_{IHmax}=3.3V$	3.0V power domain.
TXD	30	DO	Transmit data	$V_{OLmax}=0.3V$ $V_{OHmin}=2.4V$	
CTS*	31	DI	Clear to Send	$V_{OLmax}=0.3V$ $V_{OHmin}=2.4V$	
RTS*	32	DO	Request to Send	$V_{OLmax}=0.3V$ $V_{OHmin}=2.4V$	
RI	34	DO	Ring indicator	$V_{OLmax}=0.3V$ $V_{OHmin}=2.4V$	

#### UART3 Port

Pin Name	Pin No.	I/O	Description	DC Characteristics	Comment
UART3_TXD	8	DI	Receive data	$V_{OLmax}=0.3V$ $V_{OHmin}=2.4V$	$V_{OLmax}=0.3V$ $V_{OHmin}=2.4V$
UART3_RXD	9	DO	Transmit data	$V_{OLmax}=0.3V$ $V_{OHmin}=2.4V$	

#### Debug Port

Pin Name	Pin No.	I/O	Description	DC Characteristics	Comment
DBG_RXD	19	DI	Receive data	$V_{ILmax}=0.6V$ $V_{IHmin}=2.1V$ $V_{IHmax}=3.3V$	If unused, keep these pins open.
DBG_TXD	20	DO	Transmit data	$V_{OLmax}=0.3V$ $V_{OHmin}=2.4V$	If unused, keep these pins open.

#### USIM Interface

Pin Name	Pin No.	I/O	Description	DC Characteristics	Comment
USIM_VDD	38	DO	Power supply for USIM card	$V_{norm}=1.8/3.0V$	All signals of USIM interface should be protected against ESD with a TVS diode array. Maximum trace length from the module pad to USIM card connector is 200mm.
USIM_RST	39	DO	USIM card reset signal	$V_{OLmax}=0.1V \times USIM\_VDD$ $V_{OHmin}=0.8V \times USIM\_VDD$	
USIM_DATA	40	IO	USIM card data signal	$V_{OLmax}=0.1V \times USIM\_VDD$ $V_{OHmin}=0.8V \times USIM\_VDD$ $V_{ILmin}=-0.1V \times USIM\_VDD$ $V_{ILmax}=0.2V \times USIM\_VDD$	

				VDD $V_{IHmin}=0.7V \times USIM\_$ VDD $V_{IHmax}=1.1V \times USIM\_$ VDD	All signals of USIM interface should be protected against ESD with a TVS diode array. Maximum trace length from the module pad to USIM card connector is 200mm.
USIM_CLK	41	DO	USIM card clock signal	$V_{OLmax}=0.1V \times USIM\_$ VDD $V_{OHmin}=0.8V \times USIM\_$ VDD	
USIM_DETECT	37	DI	USIM card plug detect	$V_{ILmin}=-0.1V \times USIM\_$ VDD $V_{ILmax}=0.2V \times USIM\_$ VDD $V_{IHmin}=0.7V \times USIM\_$ VDD $V_{IHmax}=1.1V \times USIM\_$ VDD	
USIM_GND	42		Specified ground for USIM card		

#### SPI Interface

Pin Name	Pin No.	I/O	Description	DC Characteristics	Comment
SPI_CS	10	DO	SPI chip select	$V_{OLmax}=0.3V$ $V_{OHmin}=2.4V$	3.0V power domain. If unused, keep it open.
SPI_MISO	11	DI	SPI master input	$V_{ILmin}=-0.3V$ $V_{ILmax}=0.6V$ $V_{IHmin}=2.1V$ $V_{IHmax}=3.3V$	
SPI_CLK	12	DO	SPI clock	$V_{OLmax}=0.3V$ $V_{OHmin}=2.4V$	
SPI_MOSI	13	DO	SPI master output	$V_{OLmax}=0.3V$ $V_{OHmin}=2.4V$	

#### I2C Interface

Pin Name	Pin No.	I/O	Description	DC Characteristics	Comment
I2C_SCL	35	DO	I2C clock		An external pull-up resistor is required.
I2C_SDA	36	IO	I2C data		3.0V power domain. If unused, keep it open.

#### Other Interfaces

Pin Name	Pin No.	I/O	Description	DC Characteristics	Comment
RIO*	16	IO	Analogue PA control input/output interface	V <sub>ILmin</sub> =-0.3V V <sub>ILmax</sub> =0.6V V <sub>IHmin</sub> =2.1V V <sub>IHmax</sub> =3.3V	3.0V power domain. If unused, keep it open.
PIO1	17	IO	General purpose input/output interface	V <sub>ILmin</sub> =-0.3V V <sub>ILmax</sub> =0.6V V <sub>IHmin</sub> =2.1V V <sub>IHmax</sub> =3.3V	3.0V power domain. If unused, keep it open.
PIO2	27	IO	General purpose input output interface	V <sub>ILmin</sub> =-0.3V V <sub>ILmax</sub> =0.6V V <sub>IHmin</sub> =2.1V V <sub>IHmax</sub> =3.3V	3.0V power domain. If unused, keep it open.
<b>RF Interface</b>					
Pin Name	Pin No.	I/O	Description	DC Characteristics	Comment
RF_ANT	53	IO	RF antenna pad		Impedance of 50Ω
<b>RESERVED Pins</b>					
Pin Name	Pin No.	I/O	Description	DC Characteristics	Comment
RESERVED	1, 5, 6, 7, 14, 23~25, 28, 33, 44, 49, 50, 55~58, 67~70, 75~80, 84~91		Reserved		Keep these pins unconnected.

**NOTE**

“\*” means under development.

### 3.4. Operating Modes

BC95-D module has three operating modes, which can determine the availability of functions for different levels of power-saving.

**Table 5: Overview of Operating Modes**

Mode	Function	
Normal Operation	Active	In active mode, all functions of the module are available and all processors are active. Radio transmission and reception can be performed. Transitions to idle mode or PSM can be initiated in active mode.
	Idle	In idle mode, the module is in light sleep and network connection is maintained; paging messages can be received; transitions to active mode or PSM can be initiated in idle mode.
	PSM	In PSM, only the 32kHz RTC is working. The network is disconnected, and paging messages cannot be received either. When MO (Mobile Originated) data are sent or the periodic TAU (Tracking Area Update) timer T3412 expires, the module will be woken up.

## 3.5. Power Supply

### 3.5.1. Power Supply Pins

BC95-D provides two VBAT pins for connection with an external power supply.

The following table shows the VBAT pins and ground pins.

**Table 6: VBAT and GND Pins**

Pin Name	Pin No.	Description	Min.	Typ.	Max.	Unit
VBAT	45, 46	Power supply for the module	3.1	3.6	4.2	V
GND	2, 43, 47, 48, 51, 52, 54, 59~66, 71~74, 81~83, 92~94	Ground	-	0	-	V

### 3.5.2. Reference Design for Power Supply

The power design for the module is very important, as the performance of the module largely depends on the power source. A low quiescent current LDO which can provide sufficient input current up to 0.5A can be used as the power supply. Meanwhile, Li-SOC12 batteries can also be used to supply power for the module. The power supply range of the module is from 3.1V to 4.2V. Please make sure that the input voltage will never drop below 3.1V or rise above 4.2V even in burst transmission. If the power voltage drops below 3.1V or rise above 4.2V, the module will be abnormal.

For better power performance, it is recommended to place a 100uF tantalum capacitor with low ESR (ESR=0.7Ω) and three ceramic capacitors (100nF, 100pF and 22pF) near the VBAT pin, and a TVS diode also needs to be added on the VBAT trace to increase surge voltage withstand capability. A reference circuit is illustrated in the following figure. In principle, the longer the VBAT trace is, the wider it will be.

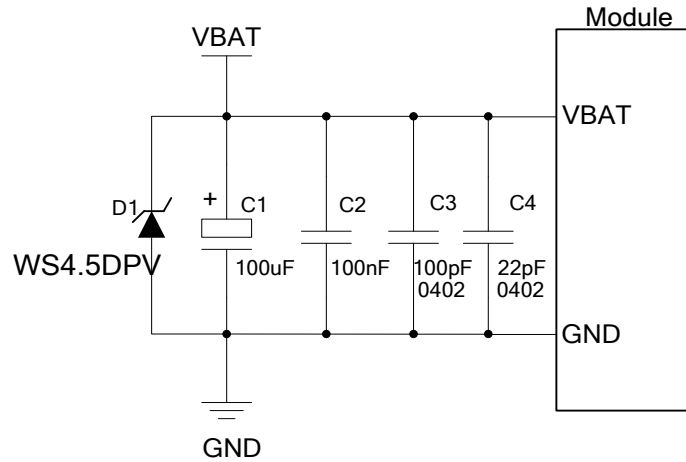

Figure 3: Reference Circuit for Power Supply

### 3.6. Turn on and off Scenarios

#### 3.6.1. Turn on

The module can be automatically turned on by supplying power source to VBAT pins.

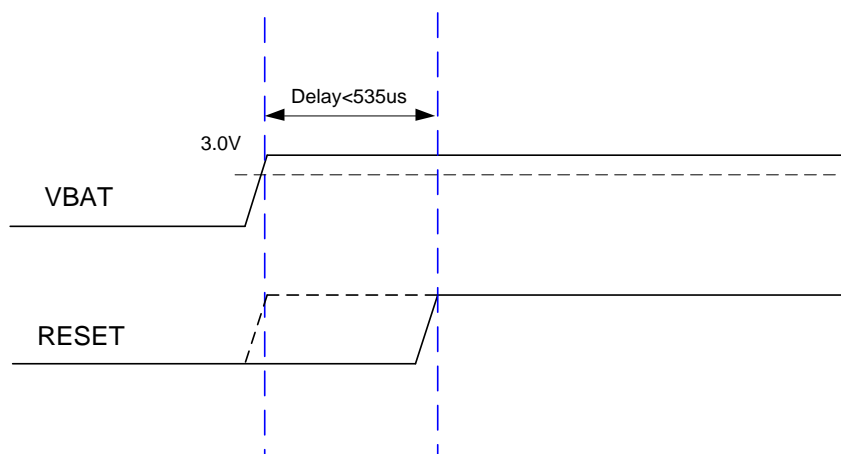

Figure 4: Turn-on Timing

### 3.6.2. Turn off

The module can be turned off by shutting down the VBAT power supply.

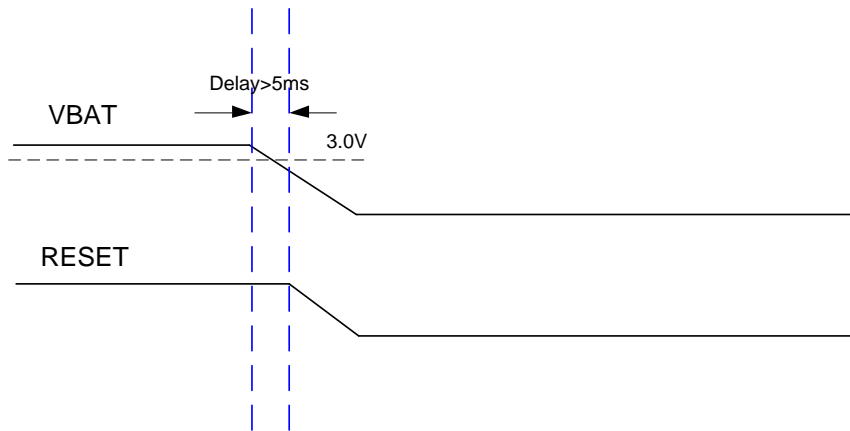

Figure 5: Turn-off Timing

### 3.6.3. Reset the Module

The module can be reset by the following two ways. The reset timing is illustrated as the following table.

- **Hardware**

Reset the module by driving the reset pin to a low level voltage for more than 100ms.

- **Software**

Reset the module using command **AT+NRB**. For more details about the command, please refer to *document [1]*.

Table 7: Reset Characteristics

Pin Name	Pin No.	Description	Reset Pull-down Time
RESET	15	Reset the module. Active low	>100ms

The recommended circuits of hardware resetting are shown as below. An open drain/collector driver or button can be used to control the RESET pin.

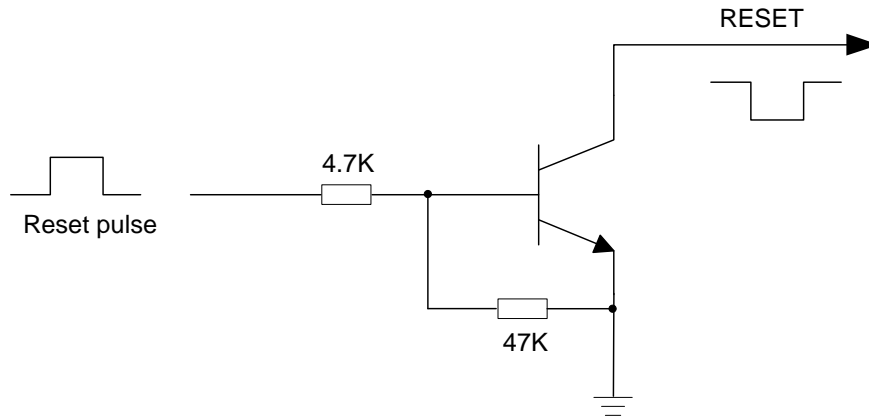

Figure 6: Reference Circuit of RESET by Using Driving Circuit

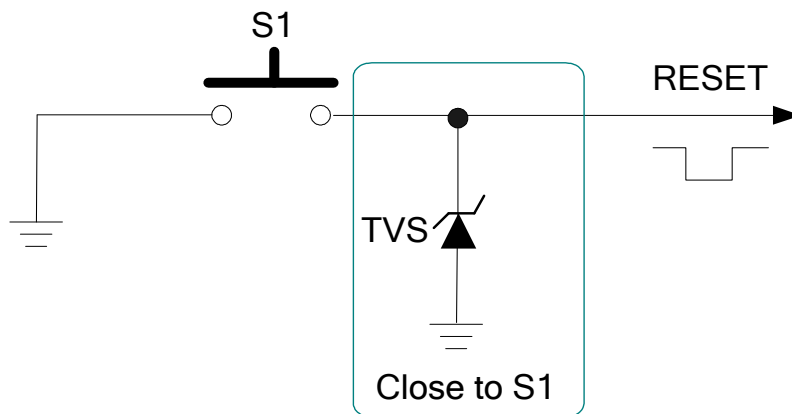
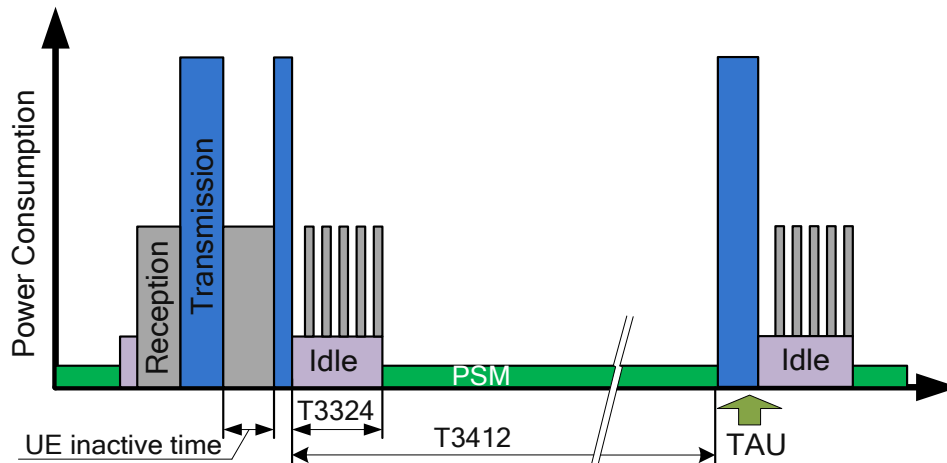

Figure 7: Reference Circuit of RESET by Using Button

### 3.7. Power Saving Mode (PSM)

Based on system performance, the module consumes a maximum current of 5uA in PSM. PSM is designed to reduce power consumption of the module and improve battery life. The following figure shows the power consumption of the module in different modes.



**Figure 8: Module Power Consumption in Different Modes**

The procedure for entering PSM is as follows: the module requests to enter PSM in “ATTACH REQUEST” message during attach/TAU (Tracking Area Update) procedure. Then the network accepts the request and provides an active time value (T3324) to the module and the mobile reachable timer starts. When the T3324 timer expires, the module enters PSM for duration of T3412 (periodic TAU timer). Please note that the module cannot request PSM when it is establishing an emergency attachment or initializing the PDN (Public Data Network) connection.

When the module is in PSM, it cannot be paged and stops access stratum activities such as cell reselection, and T3412 is still active.

When MO (Mobile Originated) data are sent or the periodic TAU timer expires, the module will exit from PSM.

### 3.8. UART Interfaces

The module provides three UART ports: main port, UART3 and debug port. The module is designed as DCE (Data Communication Equipment), following the traditional DCE-DTE (Data Terminal Equipment) connection.

The main port:

- TXD: Send data to RXD of DTE.
- RXD: Receive data from TXD of DTE.
- CTS\*: Clear to Send
- RTS\*: Request to Send
- RI: Ring indicator (when an SMS message is received or data is transmitted, the module will output signals to inform DTE).



The UART3 port:

- UART3\_TXD: Send data to RXD of DTE.
- UART3\_RXD: Receive data from TXD of DTE.

The debug port:

- DBG\_TXD: Send data to the COM port of DTE.
- DBG\_RXD: Receive data from the COM port of DTE.

The logic levels are described in the following table.

**Table 8: Pin Definition of the UART Interfaces**

Interfaces	Pin No.	Pin Name	Description	Comment
Main Port	29	RXD	Receive data	
	30	TXD	Transmit data	
	31	CTS*	Clear to Send	
	32	RTS*	Request to Send	
	34	RI	Ring indicator	Power domain: 3.0V
UART3 Port	8	UART3_TXD	Transmit data	
	9	UART3_RXD	Receive data	
Debug Port	19	DBG_RXD	Receive data	
	20	DBG_TXD	Transmit data	

**Table 9: Logic Levels of the UART Interfaces**

Parameter	Min.	Max.	Unit
V <sub>IL</sub>	-0.3	0.6	V
V <sub>IH</sub>	2.1	3.3	V
V <sub>OL</sub>		0.3	V
V <sub>OH</sub>	2.4	3.0	V

**Table 10: UART and LPUART Settings**

Parameter	Supported Value
UART Baud Rate	45.8bps to 3Mbps <sup>1)</sup>
LPUART Baud Rate	128bps to 57600bps
Parity	Even/Odd/None
Number of Stop Bits	1 or 2 bits
Data Bits Per Frame	5, 6, 7 or 8 bits

**NOTES**

1. “\*” means under development.
2. <sup>1)</sup> 1Mbps baud rate should always be supported, and a higher baud rate can be configured according to actual needs.

**3.8.1. Main Port**

The main port can be used for AT command communication and data transmission, and in such case the baud rate supports 4800bps, 9600bps and 115200bps, and the default baud rate is 9600bps. It can also be used for firmware upgrading and in such case the baud rate is 921600bps. This main port is available in active mode, idle mode and PSM. For more information about firmware upgrading, please refer to **document [2]**.

The following figure shows the connection between the DCE and DTE.

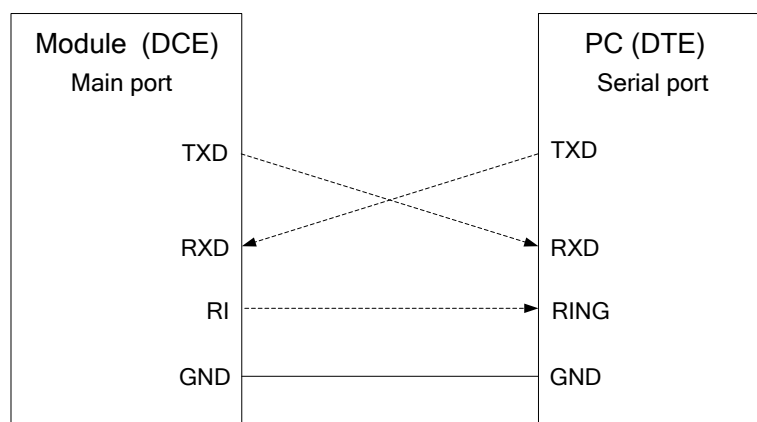

**Figure 9: Reference Design for Main Port**

### 3.8.2. Debug Port

The debug port is used to view log information with the UEMonitor tool for firmware debugging, and the baud rate is 921600bps. For detailed usage of the UEMonitor, please refer to **document [3]**.

A reference design for debug port is shown as below.

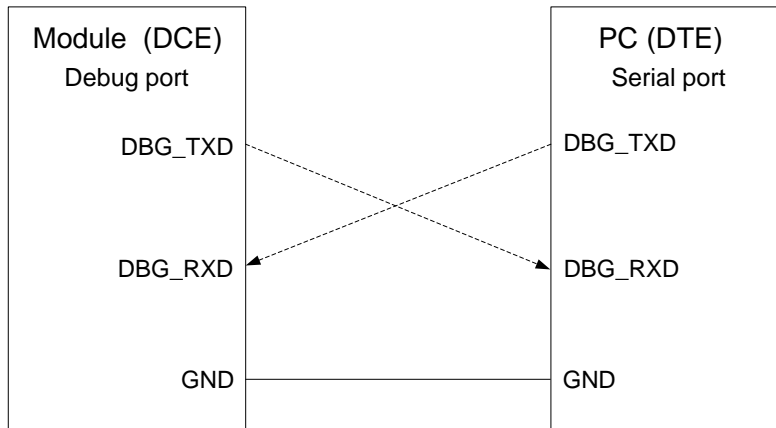

Figure 10: Reference Design for Debug Port

### 3.8.3. UART Application

A reference design of 3.3V level match is shown as below.

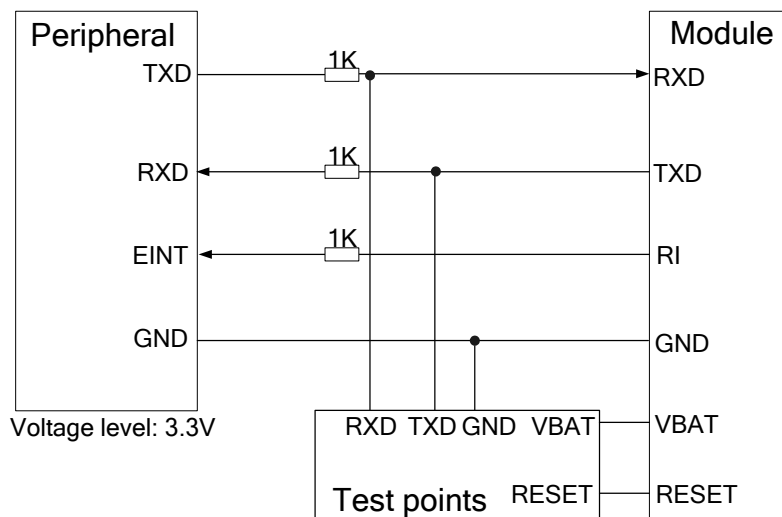
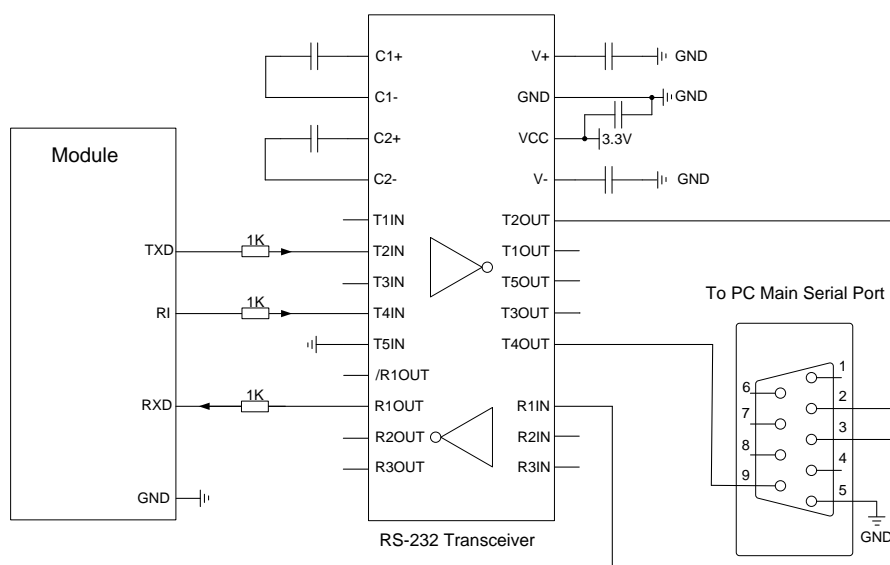

Figure 11: Level Match Design for 3.3V System

**NOTES**

1. In order to reduce the power consumption of the system, it is highly recommended to add a resistor with resistance greater than 1KΩ on the UART port signal traces when the host's voltage level is 3V or 3.3V.
2. It is recommended to reserve the test points (GND, RXD, TXD, VBAT and RESET) for firmware upgrading.

The following circuit shows a reference design for the communication between the module and PC. As the voltage level of module is 3.0V, a RS-232 transceiver must be used. Please make sure the I/O voltage of transceiver which connects to module is 3.0V.



**Figure 12: Sketch Map for RS-232 Interface Match**

Please visit vendors' web sites to select a suitable RS-232 transceiver IC, such as: <http://www.exar.com> and <http://www.maximintegrated.com>.

### 3.9. USIM Interface

The module provides one USIM interface to allow the module to access an external USIM card.

The USIM interface supports the functionality of the 3GPP specification, and is intended for use with a USIM application tool-kit.

The USIM card interface is powered by an internal regulator in the module. Both 1.8V and 3.0V USIM cards are supported.

**Table 11: Pin Definition of the USIM Interface**

Pin No.	Pin Name	Description
37	USIM_DETECT	USIM card plug in detect
38	USIM_VDD	Supply power for USIM card USIM card voltage domain is 1.8V/3.0V±5%
41	USIM_CLK	USIM card clock signal
40	USIM_DATA	USIM card data signal
39	USIM_RST	USIM card reset signal
42	USIM_GND	Specified ground for USIM card

A reference circuit for 6-pin USIM card connector is illustrated as the following figure.

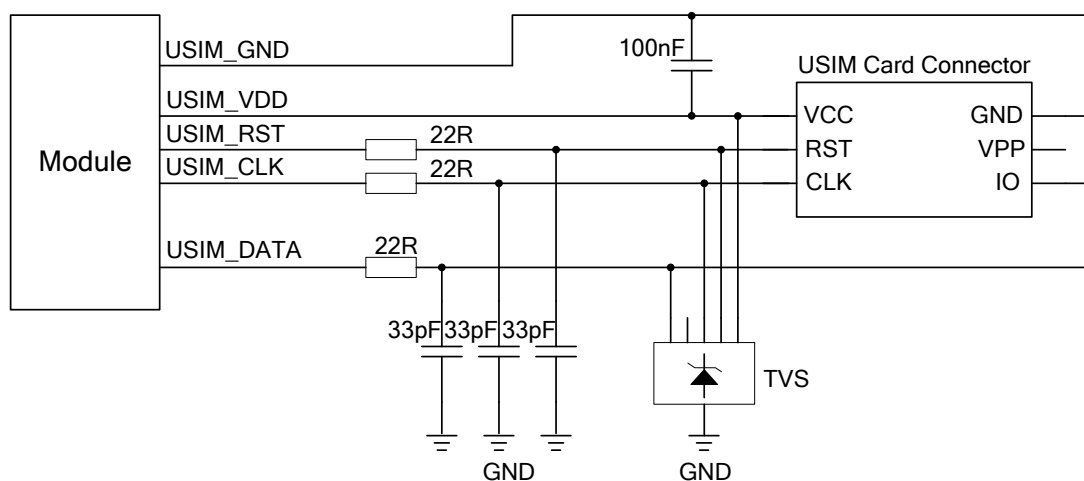

**Figure 13: Reference Circuit for USIM Interface with 6-pin USIM Card Connector**

For more information of USIM card connector, please visit <http://www.amphenol.com> and <http://www.molex.com>.

In order to enhance the reliability and availability of the USIM card in application, please follow the criteria below in USIM circuit design:

- Keep placement of USIM card connector to the module as close as possible. Keep the trace length as less than 200mm as possible.
- Keep USIM card signals away from RF and VBAT traces.
- Assure the ground between module and USIM card connector short and wide. Keep the trace width of ground no less than 0.5mm to maintain the same electric potential. The decouple capacitor of USIM\_VDD is less than 1uF and must be near to USIM card connector.

- To avoid cross talk between USIM\_DATA and USIM\_CLK, keep them away from each other and shield them with surrounded ground. USIM\_RST should also be ground shielded.
- In order to offer good ESD protection, it is recommended to add a TVS diode array. For more information of TVS diode, please visit <http://www.onsemi.com>. The most important rule is to place the ESD protection device close to the USIM card connector and make sure the USIM card interface signal traces being protected will go through the ESD protection device first and then lead to the module. The 22Ω resistors should be connected in series between the module and the USIM card connector so as to suppress EMI spurious transmission and enhance ESD protection. Please note that the USIM peripheral circuit should be close to the USIM card connector.
- Place the RF bypass capacitors (33pF) close to the USIM card connector on all signals traces to improve EMI suppression.

### 3.10. ADC Interface

The module provides a 10-bit ADC input channel to read the voltage value. This ADC interface is available in both active and idle modes.

**Table 12: Pin Definition of the ADC**

Pin Name	Pin No.	Description
ADC	21	Analog to digital converter interface

**Table 13: Characteristics of the ADC**

Item	Min.	Typ.	Max.	Unit
Full-scale Range (FSR)	Gain=0	1.45		V
	Gain=1	2		V
	Gain=2	2.5		V
	Gain=3	3		V
	Gain=4	3.5		V
	Gain=5	4		V
Sampling Frequency	0		5	MHz
Input Impedance	100			MΩ

Supply Current (from VBAT)		350		uA
INL			2	lsb
Offset	-10		10	mV
Overall Accuracy <sup>1)</sup>	-2.5	0	+2.5	%

**NOTE**

<sup>1)</sup>The overall accuracy is measured after calibration against internal reference.

### 3.11. DAC Interface

The module provides a 10-bit DAC output channel.

**Table 14: Pin Definition of the DAC**

Pin Name	Pin No.	Description
DAC	22	Digital to analog converter interface

**Table 15: Characteristics of the DAC**

Item	Min.	Typ.	Max.	Unit
LSB Voltage Step		Gain=0	1.2	mV
		Gain=1	2.0	mV
		Gain=2	2.8	mV
		Gain=3	3.5	mV
LSB Voltage Step Accuracy	-4		4	%
Zero Crossing Offset (Nominal Output at 0 Input)	-75	0	75	mV
Linearity, INL (VOUT > 20mV)			2	LSB

Linearity, DNL		2	LSB
Supply Current (at Zero Output Load)	100	150	uA
Output Current Capability	-1	1	mA
Output Driver Impedance (C load < 20pF)		1	Ω
Output Driver Impedance (Any C Load)		200	Ω
Maximum Signal Frequency		500	kHz
RMS Output Noise		0.5	LSB

### 3.12. SPI Interface

The module provides a serial peripheral interface (SPI).

**Table 16: Pin Definition of the SPI**

Pin Name	Pin No.	Description
SPI_CS	10	SPI chip select
SPI_MISO	11	SPI master input
SPI_CLK	12	SPI clock
SPI_MOSI	13	SPI master output

### 3.13. I2C Interface

The module provides an I2C interface.

**Table 17: Pin Definition of the I2C**

Pin Name	Pin No.	Description
I2C_SCL	35	I2C clock



I2C\_SDA                      36                      I2C data

### 3.14. Behaviors of RI

When an SMS message is received or certain URCs are reported, RI pin will be triggered. The behaviors of RI are shown as below.

**Table 18: Behaviors of RI**

State	RI Response
Idle	HIGH
SMS	When an SMS message is received, the RI is changed to LOW and kept at low level for about 120ms. Then it is changed to HIGH.
URC	Certain URCs can trigger RI to LOW for 120ms before the URC comes out. Then it is changed to HIGH.

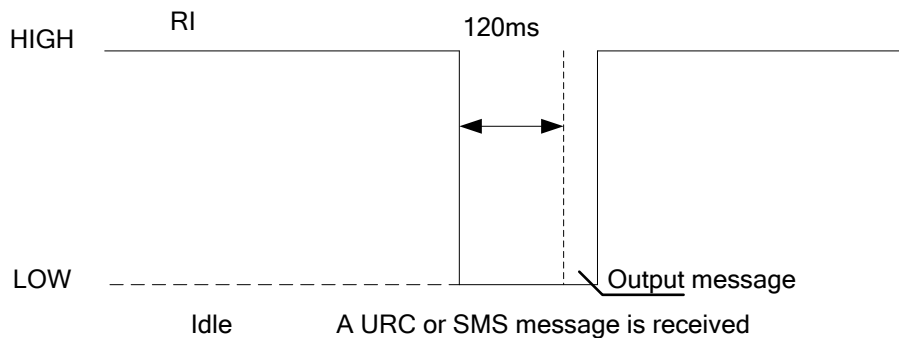

**Figure 14: Behaviors of RI when a URC or SMS Message is Received**

**NOTE**

Please pull down the RI pin for more than 120ms, the maximum time depends on the URC data output length and the baud rate of the serial port.

### 3.15. Network Status Indication

The NETLIGHT signal can be used to drive a network status indication LED. The working state of this pin is listed in the following table.

**Table 19: Working State of NETLIGHT**

State	Module Function
Low (Light off)	The module is not working or not attached to network.
High (Light on)	The module is attached to network.

A reference circuit is shown as below.

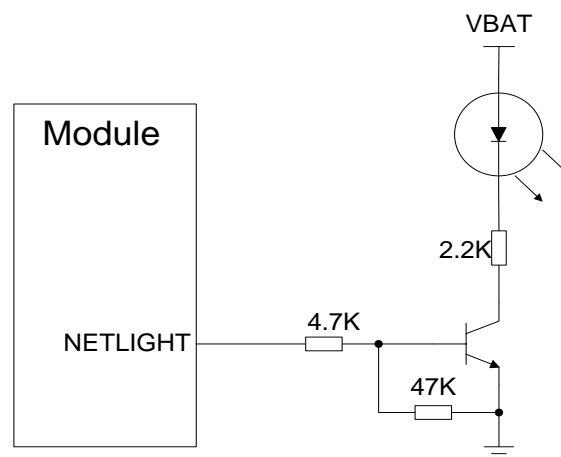

**Figure 15: Reference Design for NETLIGHT**

# 4 Antenna Interface

The pin 53 is the RF antenna pad. The impedance of the antenna port is 50Ω.

**Table 20: Pin Definition of the RF Antenna Interface**

Pin Name	Pin No.	Description
GND	51	Ground
GND	52	Ground
RF_ANT	53	RF antenna pad
GND	54	Ground

## 4.1. RF Antenna Reference Design

A reference design for RF antenna is shown as below.

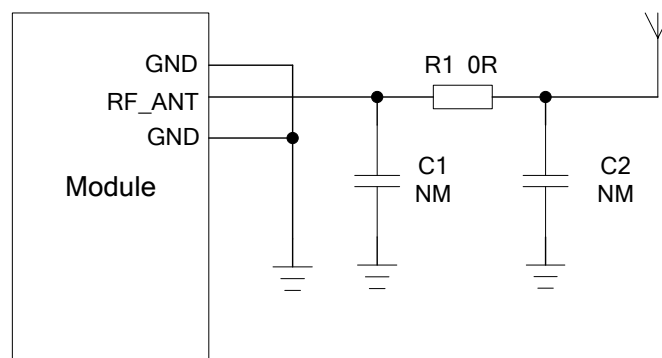

**Figure 16: Reference Design for RF Antenna**

BC95-D provides an RF antenna pad for antenna connection. There is a ground pad on each side of the antenna pad in order to give a better grounding. Additionally, a  $\pi$ -type matching circuit is recommended to be used to adjust the RF performance. Please place the  $\pi$ -type matching components (R1/C1/C2) as close to the antenna as possible, and mount them according to actual needs. The capacitors (C1/C2) are

not mounted and a 0Ω resistor is mounted on R1 by default.

## 4.2. Reference Design of RF Layout

For user's PCB, the characteristic impedance of all RF traces should be controlled as  $50\Omega \pm 10\%$ . The impedance of the RF traces is usually determined by the trace width ( $W$ ), the materials' dielectric constant, the distance between signal layer and reference ground ( $H$ ), and the clearance between RF trace and ground ( $S$ ). Microstrip line or coplanar waveguide line is typically used in RF layout for characteristic impedance control. The following are reference designs of microstrip line or coplanar waveguide line with different PCB structures.

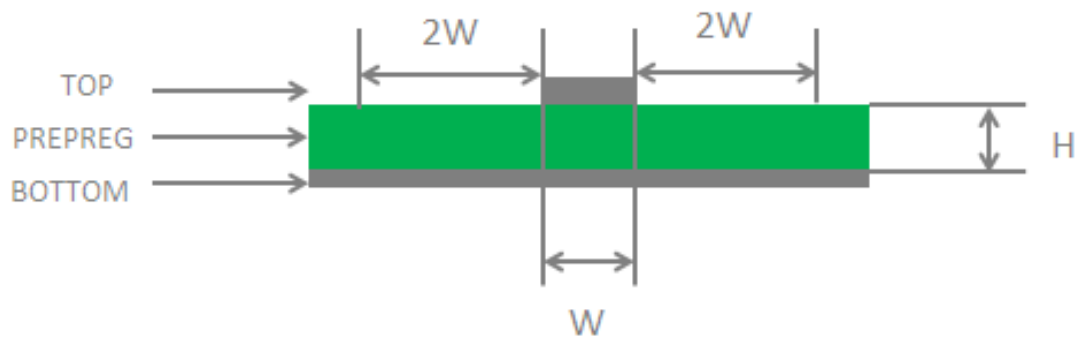

Figure 17: Microstrip Line Design on a 2-layer PCB

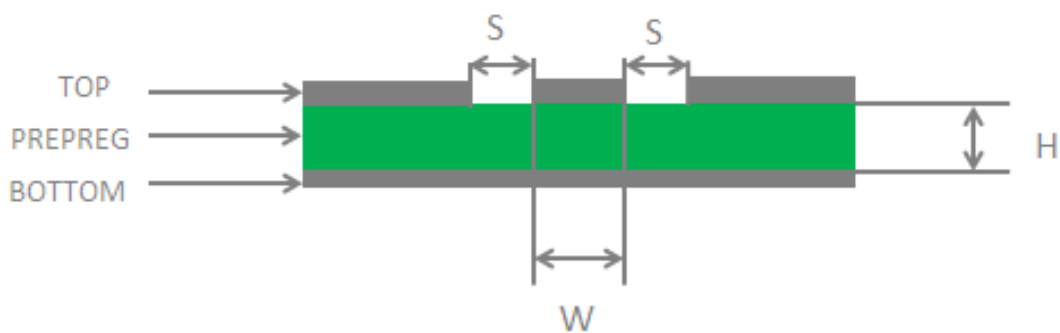

Figure 18: Coplanar Waveguide Line Design on a 2-layer PCB

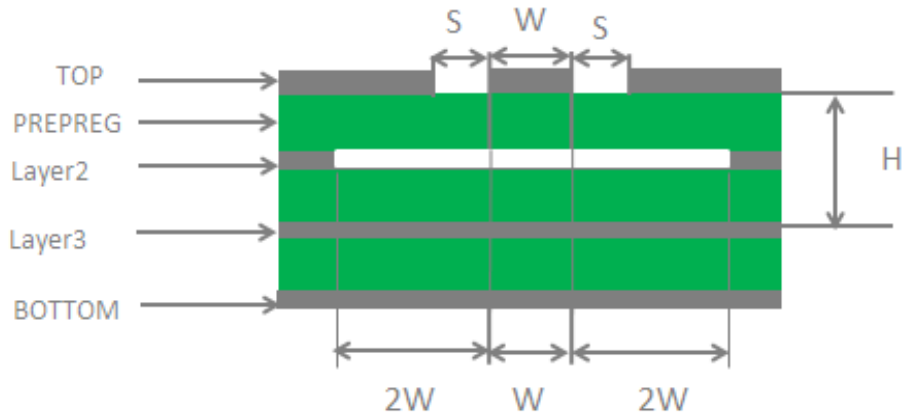

Figure 19: Coplanar Waveguide Line Design on a 4-layer PCB (Layer 3 as Reference Ground)

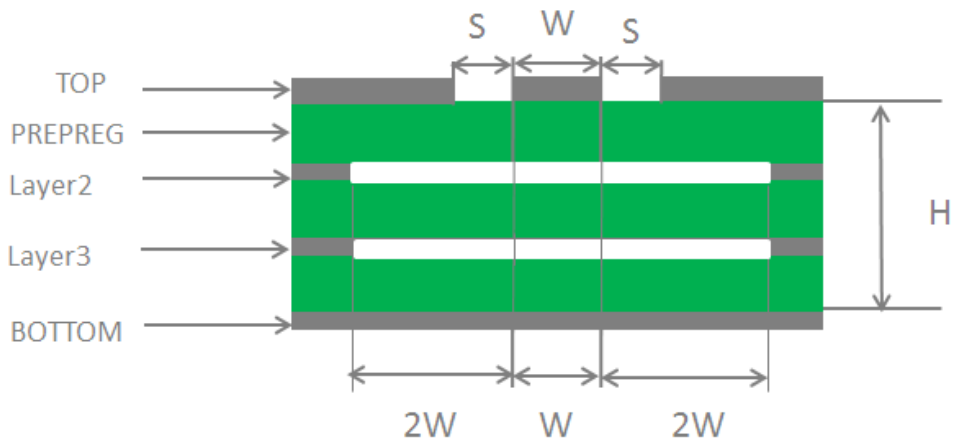

Figure 20: Coplanar Waveguide Line Design on a 4-layer PCB (Layer 4 as Reference Ground)

In order to ensure RF performance and reliability, the following principles should be complied with in RF layout design:

- Use an impedance simulation tool to control the characteristic impedance of RF traces as  $50\Omega \pm 10\%$ .
- The GND pins adjacent to RF pins should not be designed as thermal relief pads, and should be fully connected to ground.
- The distance between the RF pins and the RF connector should be as short as possible, and all the right angle traces should be changed to curved ones.
- There should be clearance area under the signal pin of the antenna connector or solder joint.
- The reference ground of RF traces should be complete. Meanwhile, adding some ground vias around RF traces and the reference ground could help to improve RF performance. The distance between the ground vias and RF traces should be no less than two times the width of RF signal traces ( $2*W$ ).

For more details about RF layout, please refer to **document [5]**.

### 4.3. RF Output Power

Table 21: RF Output Power (Uplink QPSK and BPSK Modulation)

Frequency	Max.	Min.
1915MHz~1920MHz	23dBm±2dB	<-40dBm

#### NOTE

The design is compliant with the NB-IoT radio protocol *3GPP Rel. 14*.

### 4.4. RF Receiving Sensitivity

Table 22: RF Receiving Sensitivity (Throughput ≥ 95%)

Frequency	Receiving Sensitivity
722MHz~728MHz	-129dBm±2dB
1995MHz~2020MHz	-129dBm±2dB

#### NOTE

The RF receiving sensitivity is tested under target BLER=10%, 1T1R, AWGN and MCS0 with Rep128.

### 4.5. Operating Frequencies

Table 23: Operating Frequencies

Frequency Bands	Transmit	Receive
B111	1915MHz~1920MHz	722MHz~728MHz

B222

1915MHz~1920MHz

1995MHz~2020MHz

## 4.6. Antenna Requirement

The following table shows the requirement on NB-IoT antenna.

**Table 24: Antenna Requirement**

Type	Requirement
Frequency Range	720MHz~730MHz; 1915MHz~2020MHz
Max Input Power (W)	5
Input Impedance ( $\Omega$ )	50
Polarization Type	Linear

## 4.7. Recommended RF Connector for Antenna Installation

If RF connector is used for antenna connection, it is recommended to use SMA-F connector.

# 5 Electrical, Reliability and Radio Characteristics

## 5.1. Absolute Maximum Ratings

Absolute maximum ratings for power supply and voltage on digital and analog pins of the module are listed in the following table.

**Table 25: Absolute Maximum Ratings**

Parameter	Min.	Max.	Unit
VBAT	-0.3	+4.25	V
Current of Power Supply	0	0.8	A
Voltage at Digital Pins	-0.3	+4.25	V
Voltage at Analog Pins	-0.3	+4.25	V
Voltage at Digital/Analog Pins in Power Down Mode	-0.25	+0.25	V

## 5.2. Operation and Storage Temperatures

The operation and storage temperatures are listed in the following table.

**Table 26: Operation and Storage Temperatures**

Parameter	Min.	Typ.	Max.	Unit
Operation Temperature Range <sup>1)</sup>	-40	+25	+85	°C



Storage Temperature Range	-40	+90	°C
---------------------------	-----	-----	----

**NOTE**

<sup>1)</sup> Within operation temperature range, the module is 3GPP compliant.

### 5.3. Current Consumption

The values of current consumption are shown below.

**Table 27: Current Consumption**

Parameter	Description	Conditions	Min.	Typ.	Max.	Unit	
I <sub>VBAT</sub>	PSM	Deep sleep state		3.6	5	uA	
	Idle mode	Standby state @DRX=1.28s		2		mA	
	Active mode		Radio transmission @23dBm (Single-tone)		250		mA
			Radio transmission @23dBm (Multi-tone)		350		mA
			Radio transmission @25dBm (Single-tone)		350		mA
			Radio reception		50		mA

### 5.4. Electrostatic Discharge

The module is not protected against electrostatic discharge (ESD) in general. Consequently, it is subject to ESD handling precautions that typically apply to ESD sensitive components. Proper ESD handling and packaging procedures must be applied throughout the processing, handling and operation of any application that incorporates the module.

The following table shows the module's electrostatic discharge characteristics.

**Table 28: Electrostatic Discharge Characteristics**

Test Points	Contact Discharge	Air Discharge	Unit
VBAT, GND	±5	±10	kV
Antenna Interface	±5	±10	kV
Other Interfaces	±0.5	±1	kV

# 6 Mechanical Dimensions

This chapter describes the mechanical dimensions of the module. All dimensions are measured in mm. The tolerances for dimensions without tolerance values are  $\pm 0.05\text{mm}$ .

## 6.1. Mechanical Dimensions of the Module

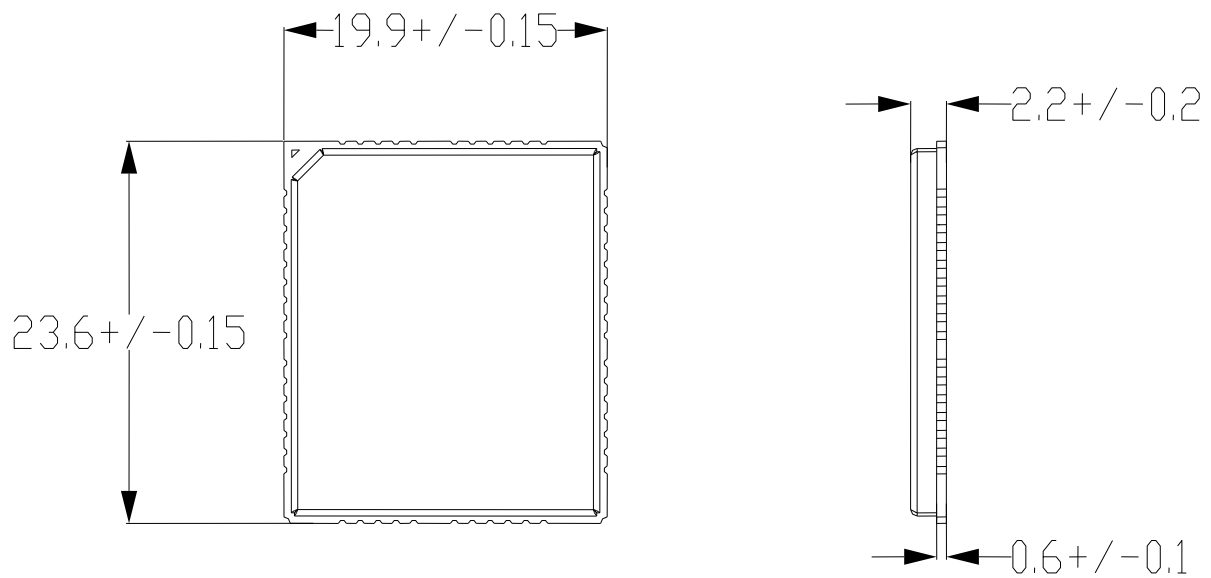

Figure 21: Module Top and Side Dimensions

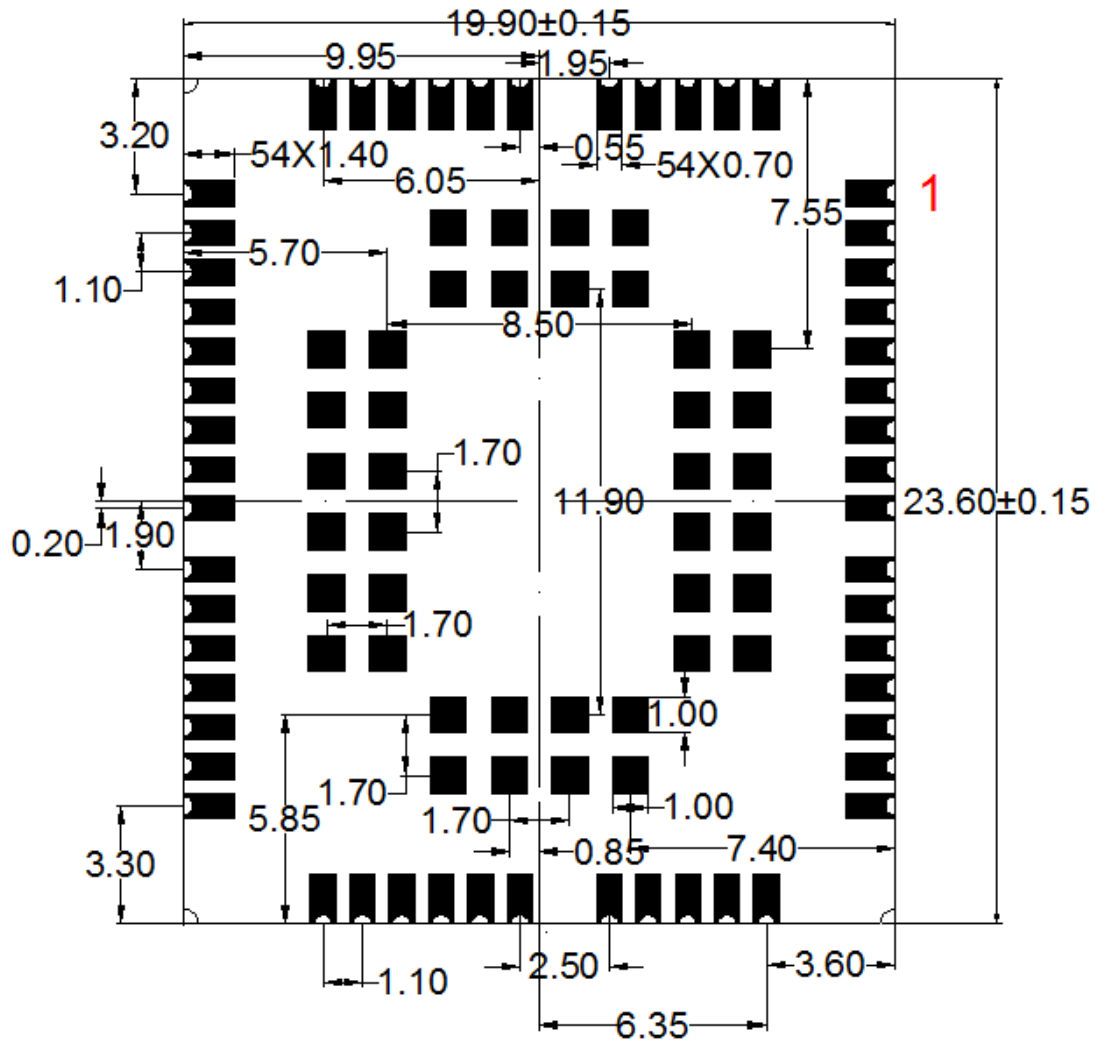

Figure 22: Module Bottom Dimensions (Bottom View)

## 6.2. Recommended Footprint

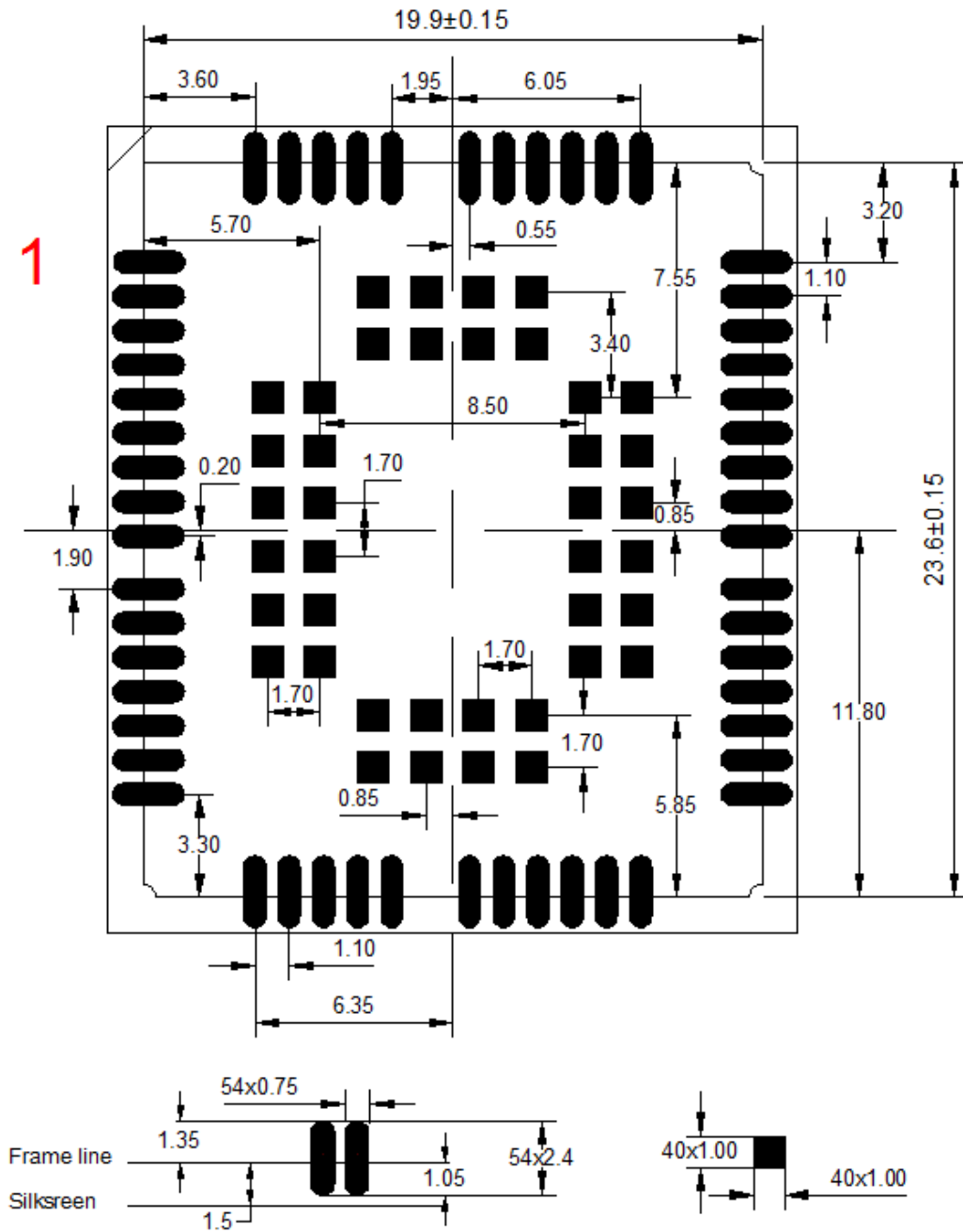

Figure 23: Recommended Footprint (Top View)

### NOTES

1. For easy maintenance of the module, please keep about 3mm between the module and other components in the host PCB.
2. All RESERVED pins must not be connected to GND.

### 6.3. Design Effect Drawings of the Module



Figure 24: Top View of the Module

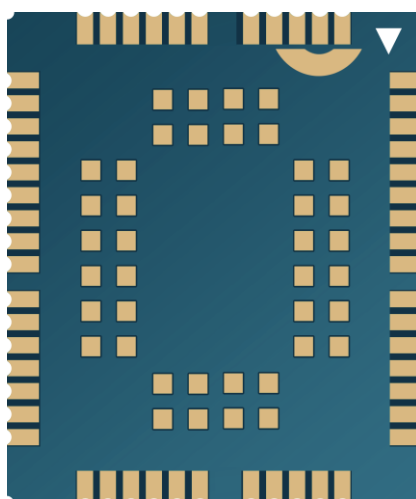

Figure 25: Bottom View of the Module

**NOTE**

These are design effect drawings of BC95-D module. For more accurate pictures, please refer to the module that you get from Quectel.

# 7 Storage, Manufacturing and Packaging

## 7.1. Storage

BC95-D module is stored in a vacuum-sealed bag. It is rated at MSL 3, and its storage restrictions are shown as below.

1. Shelf life in the vacuum-sealed bag: 12 months at <math><40^{\circ}\text{C}/90\%\text{RH}</math>.
2. After the vacuum-sealed bag is opened, devices that will be subjected to reflow soldering or other high temperature processes must be:
  - Mounted within 168 hours at the factory environment of  $\leq 30^{\circ}\text{C}/60\% \text{RH}$ .
  - Stored at <math><10\% \text{RH}</math>.
3. Devices require baking before mounting, if any circumstance below occurs:
  - When the ambient temperature is  $23^{\circ}\text{C}\pm 5^{\circ}\text{C}$  and the humidity indication card shows the humidity is >10% before opening the vacuum-sealed bag.
  - Device mounting cannot be finished within 168 hours at factory conditions of  $\leq 30^{\circ}\text{C}/60\%$
4. If baking is required, devices may be baked for 8 hours at  $120^{\circ}\text{C}\pm 5^{\circ}\text{C}$ .

### NOTE

As the plastic package cannot be subjected to high temperature, it should be removed from devices before high temperature ( $120^{\circ}\text{C}$ ) baking. If shorter baking time is desired, please refer to the *IPC/JEDECJ-STD-033* for baking procedure.

## 7.2. Manufacturing and Soldering

Push the squeegee to apply the solder paste on the surface of stencil, thus making the paste fill the stencil openings and then penetrate to the PCB. The force on the squeegee should be adjusted properly so as to produce a clean stencil surface on a single pass. To ensure the module soldering quality, the thickness of stencil for the module is recommended to be 0.15mm. For more details, please refer to **document [4]**.

It is suggested that the peak reflow temperature is 235°C~245°C (for SnAg3.0Cu0.5 alloy). The absolute max reflow temperature is 260°C. To avoid damage to the module caused by repeatedly heating, it is suggested that the module should be mounted after reflow soldering for the other side of PCB has been completed. Recommended reflow soldering thermal profile is shown below.

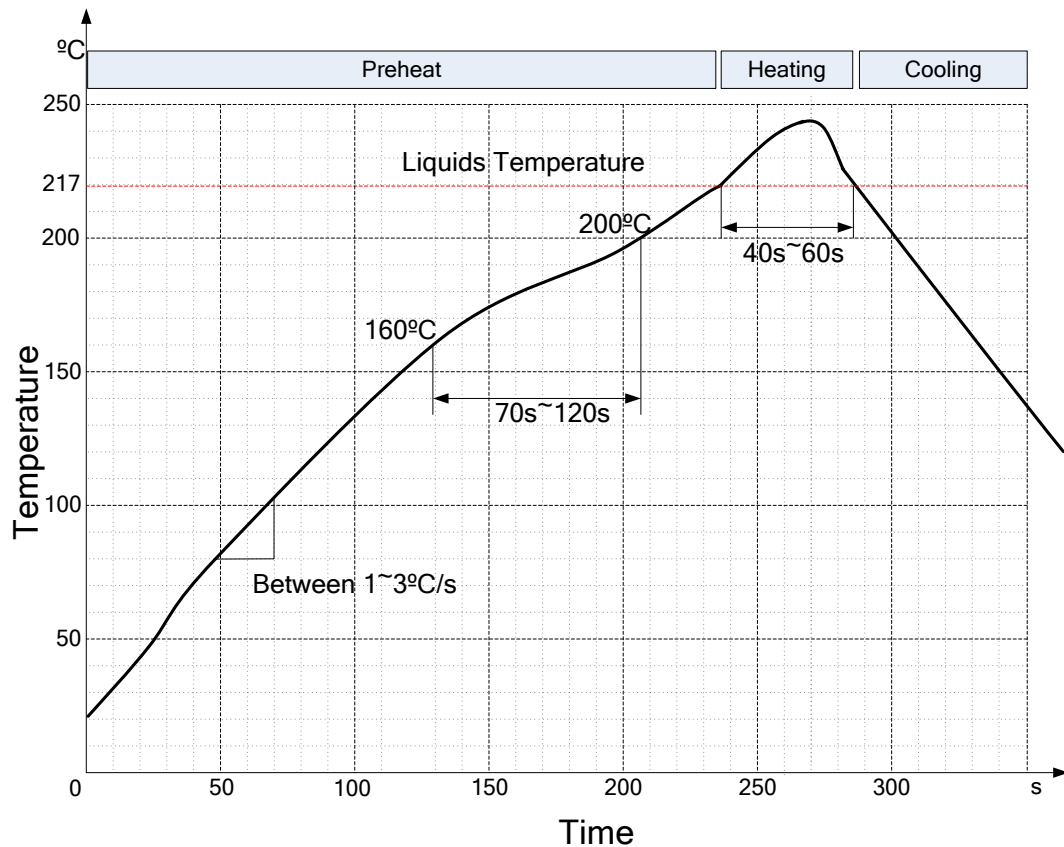

Figure 26: Reflow Soldering Thermal Profile

### NOTES

1. During manufacturing and soldering, or any other processes that may contact the module directly, NEVER wipe the module's shielding can with organic solvents, such as acetone, ethyl alcohol, isopropyl alcohol, trichloroethylene, etc. Otherwise, the shielding can may become rusted.



- The shielding can for the module is made of Cupro-Nickel base material. It is tested that after 12 hours' Neutral Salt Spray test, the laser engraved label information on the shielding can is still clearly identifiable and the QR code is still readable, although white rust may be found.

### 7.3. Packaging

The modules are stored inside a vacuum-sealed bag which is ESD protected. It should not be opened until the devices are ready to be soldered onto the application.

#### 7.3.1. Tape and Reel Packaging

The reel is 330mm in diameter and each reel contains 250 modules.

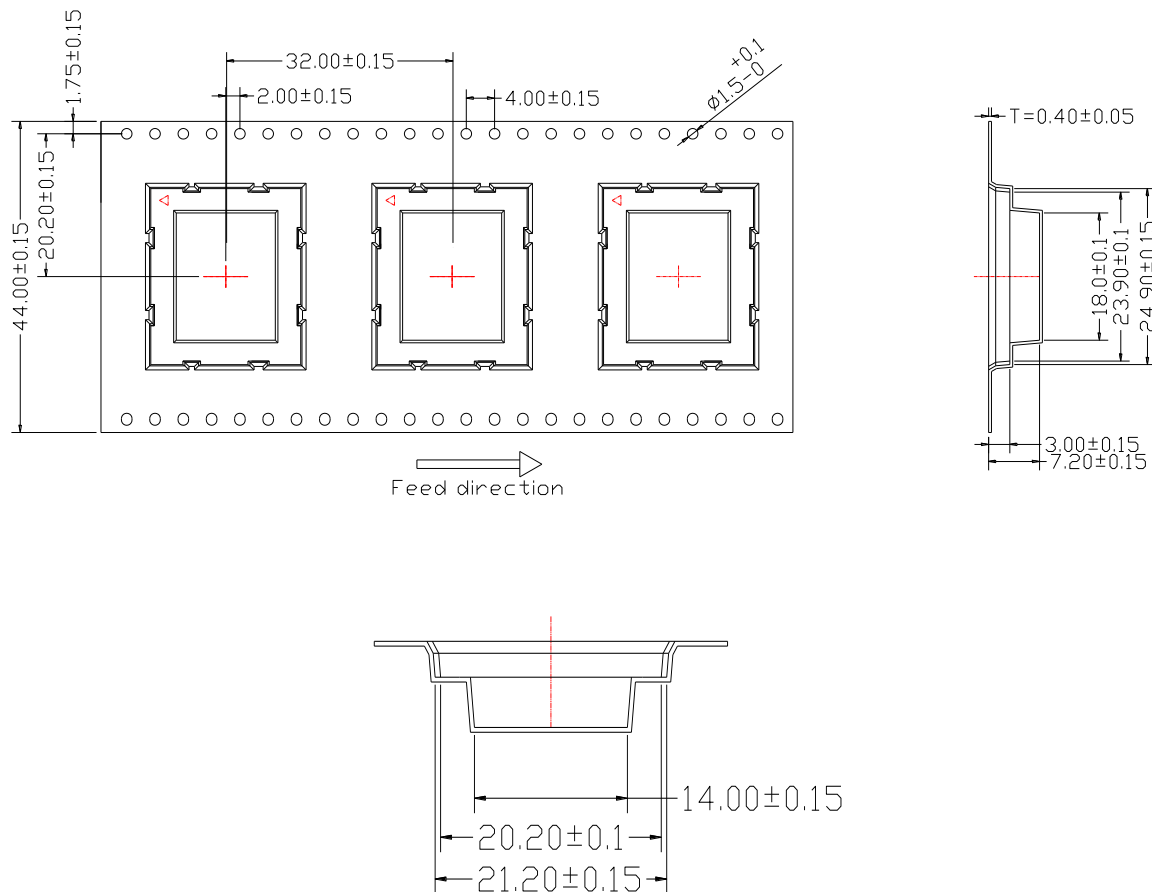

**Figure 27: Tape Dimensions**

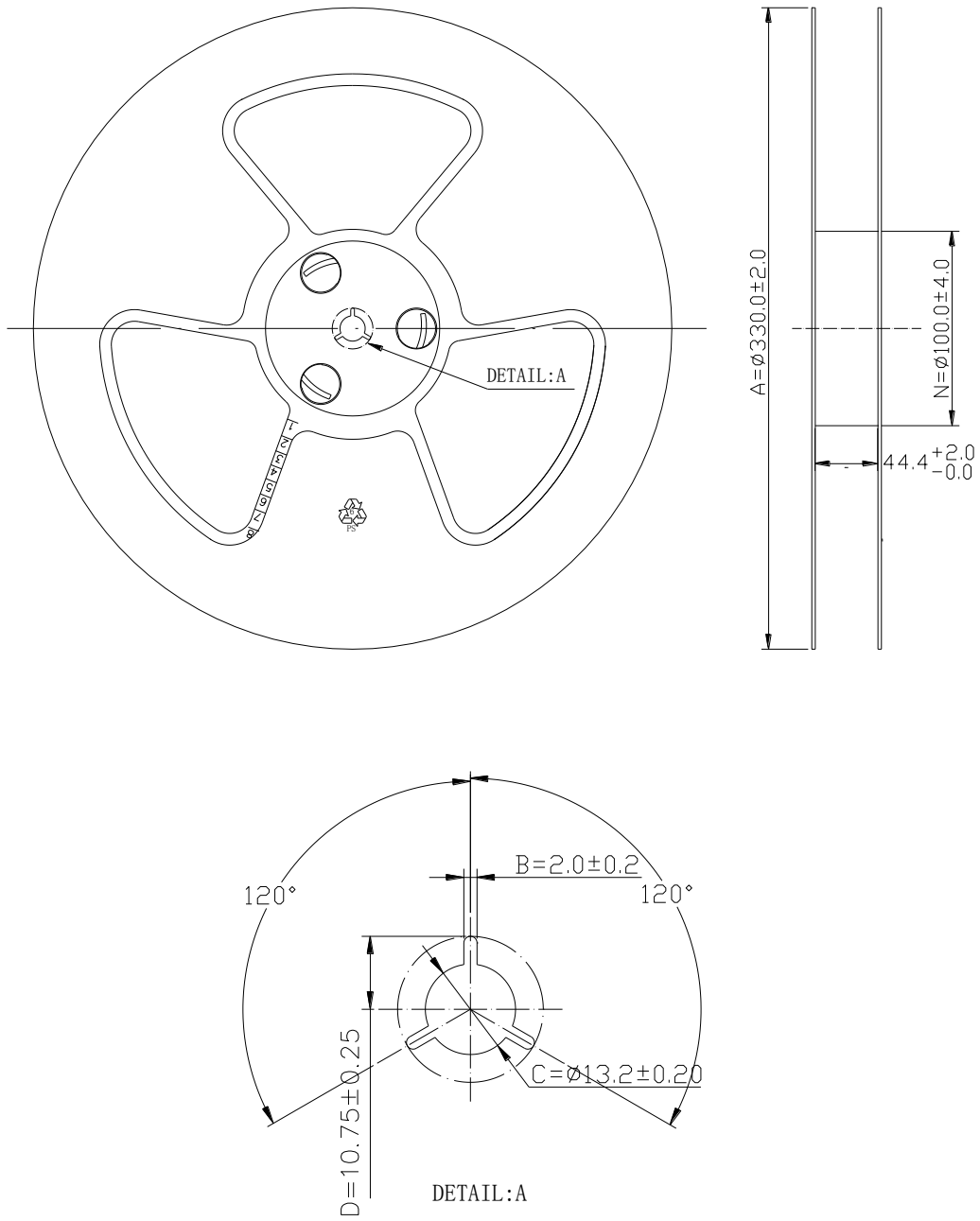

**Figure 28: Reel Dimensions**

# 8 Appendix A References

**Table 29: Related Documents**

SN	Document Name	Remark
[1]	Quectel_BC95-D_AT_Commands_Manual	BC95-D AT Commands Manual
[2]	Quectel_BC95-D_Firmware_Upgrade_User_Guide	BC95-D Firmware Upgrade User Guide
[3]	Quectel_BC95-D_UEMonitor_User_Guide	BC95-D UEMonitor User Guide
[4]	Quectel_Module_Secondary_SMT_User_Guide	Module Secondary SMT User Guide
[5]	Quectel_RF_Layout_Application_Note	RF Layout Application Note
[6]	NL-002871-SP-2C-Hi2115 C30 Datasheet	Datasheet on which this document is based
[7]	Quectel_BC95-D_Reference_Design	BC95-D Reference Design

**Table 30: Terms and Abbreviations**

Abbreviation	Description
ADC	Analog-to-Digital Converter
AS	Access Stratum
DAC	Digital-to-Analog Converter
DCE	Data Communications Equipment (typically module)
DNL	Differential Nonlinearity
DTE	Data Terminal Equipment (typically computer, external controller)
DRX	Discontinuous Reception
H-FDD	Half Frequency Division Duplexing

---

I/O	Input/Output
IC	Integrated Circuit
I <sub>max</sub>	Maximum Load Current
INL	Integral Nonlinearity
I <sub>norm</sub>	Normal Current
kbps	Kilo Bits Per Second
LED	Light Emitting Diode
LPUART	Low Power Universal Asynchronous Receiver/Transmitter
LSB	Least Significant Bit
MME	Mobility Management Entity
MO	Mobile Originated
NB-IoT	Narrow Band Internet of Things
PCB	Printed Circuit Board
PDN	Public Data Network
PSM	Power Saving Mode
RF	Radio Frequency
RoHS	Restriction of Hazardous Substances
RTC	Real Time Clock
RX	Receive Direction
USIM	Universal Subscriber Identification Module
SMS	Short Message Service
TAU	Tracking Area Update
TE	Terminal Equipment
TX	Transmitting Direction
UART	Universal Asynchronous Receiver & Transmitter

---

---

URC	Unsolicited Result Code
VSWR	Voltage Standing Wave Ratio
Vmax	Maximum Voltage Value
Vnorm	Normal Voltage Value
Vmin	Minimum Voltage Value
VIHmax	Maximum Input High Level Voltage Value
VIHmin	Minimum Input High Level Voltage Value
VILmax	Maximum Input Low Level Voltage Value
VILmin	Minimum Input Low Level Voltage Value
VImax	Absolute Maximum Input Voltage Value
VImin	Absolute Minimum Input Voltage Value
VOHmax	Maximum Output High Level Voltage Value
VOHmin	Minimum Output High Level Voltage Value
VOLmax	Maximum Output Low Level Voltage Value
VOLmin	Minimum Output Low Level Voltage Value

---

## FCC Certification Requirements.

According to the definition of mobile and fixed device is described in Part 2.1091(b), this device is a mobile device.

And the following conditions must be met:

1. This Modular Approval is limited to OEM installation for mobile and fixed applications only. The antenna installation and operating configurations of this transmitter, including any applicable source-based time-averaging duty factor, antenna gain and cable loss must satisfy MPE categorical Exclusion Requirements of 2.1091.
2. The EUT is a mobile device; maintain at least a 20 cm separation between the EUT and the user's body and must not transmit simultaneously with any other antenna or transmitter.
3. A label with the following statements must be attached to the host end product: This device contains FCC ID: XMR201807BC95D.
4. To comply with FCC regulations limiting both maximum RF output power and human exposure to RF radiation, maximum antenna gain (including cable loss) must not exceed:
  - Band111(Tx: 1915MHz~1920MHz): <4dBi
  - Band222(Tx: 1915MHz~1920MHz): <4dBi
5. This module must not transmit simultaneously with any other antenna or transmitter
6. The host end product must include a user manual that clearly defines operating requirements and conditions that must be observed to ensure compliance with current FCC RF exposure guidelines.

For portable devices, in addition to the conditions 3 through 6 described above, a separate approval is required to satisfy the SAR requirements of FCC Part 2.1093

If the device is used for other equipment that separate approval is required for all other operating configurations, including portable configurations with respect to 2.1093 and different antenna configurations.

For this device, OEM integrators must be provided with labeling instructions of finished products.

Please refer to KDB784748 D01 v07, section 8. Page 6/7 last two paragraphs:

A certified modular has the option to use a permanently affixed label, or an electronic label. For a permanently affixed label, the module must be labeled with an FCC ID - Section 2.926 (see 2.2 Certification (labeling requirements) above). The OEM manual must provide clear instructions explaining to the OEM the labeling requirements, options and OEM user manual instructions that are required (see next paragraph).

For a host using a certified modular with a standard fixed label, if (1) the module's FCC ID is not visible when installed in the host, or (2) if the host is marketed so that end users do not have straightforward commonly used methods for access to remove the module so that the FCC ID of the module is visible; then an additional permanent label referring to the enclosed module: "Contains Transmitter Module FCC ID: XMR201807BC95D" or "Contains FCC ID: XMR201807BC95D" must be used. The host OEM user manual must also contain clear instructions on how end users can find and/or access the module and the FCC ID.

The final host / module combination may also need to be evaluated against the FCC Part 15B criteria for unintentional radiators in order to be properly authorized for operation as a Part 15 digital device.

The user's manual or instruction manual for an intentional or unintentional radiator shall caution the user that changes or modifications not expressly approved by the party responsible for compliance could void the user's authority to operate the equipment. In cases where the manual is provided only in a form other than paper, such as on a computer disk or over the Internet, the information required by this section may be included in the manual in that alternative form, provided the user can reasonably be expected to have the capability to access information in that form.

This device complies with part 15 of the FCC Rules. Operation is subject to the following two conditions: (1) This device may not cause harmful interference, and (2) this device must accept any interference received, including interference that may cause undesired operation.

Changes or modifications not expressly approved by the manufacturer could void the user's authority to

operate the equipment.

To ensure compliance with all non-transmitter functions the host manufacturer is responsible for ensuring compliance with the module(s) installed and fully operational. For example, if a host was previously authorized as an unintentional radiator under the Declaration of Conformity procedure without a transmitter certified module and a module is added, the host manufacturer is responsible for ensuring that the after the module is installed and operational the host continues to be compliant with the Part 15B unintentional radiator requirements.