

RF2000BP OPERATING INSTRUCTIONS

TERMS

- Half Duplex:
Combined speaker and mic at the menu board
- Full Duplex:
Separate speaker and mic at the menu board
- Hands-Free:
Automatic two-way communication (Talk and Listen) without touching the belt pack again (Operates in Full Duplex system only).

POWER ON

- Slide battery cover off, insert battery, slide batter cover on
- Rotate on/volume control knob clockwise; power light goes on

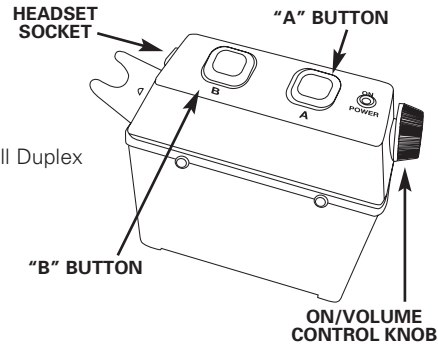

OPERATING MODES

- 1 HANDS-FREE DISABLED MODE: (Battery cavity upper dip switch #4 in **UP** Position)
 - Press and hold "A" button to talk to customer; release to listen
 - To talk to the customer again or to the next customer, press and hold the "A" button; release to listen
 - When vehicle exits, system becomes silent
 - 2 HANDS-FREE ENABLED MODE: (Battery cavity upper dip switch #4 in **DOWN** Position)
 - Press "A" button once to automatically Talk and Listen to customer (Power light blinks continuously in this mode)
 - When vehicle exits, the system becomes silent, but outbound audio will still be heard
 - Hands-Free is turned off when either the "A" or "B" button is pressed, or the belt pack is turned off
- (See reverse side for illustration)

NOTE: After a vehicle exits the drive-thru area, the inbound audio mutes. When the next car arrives, the vehicle-present tone is heard in the headset and two-way communication with the customer can begin.

To communicate with other personnel wearing Belt Packs without being heard by the customer:

- Press the "B" button and speak
- Release the "B" button immediately after speaking since the "B" channel overrides the "A" channel and will cut out any ongoing communication with the customer.

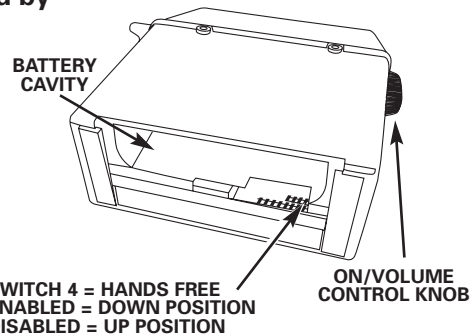

Compliance Statement (Part 15.19)

This device complies with Part 15 of the FCC Rules. Operation is subject to the following two condition:

1. This device may not cause harmful interference, and
2. This device must accept any interference received, including interference that may cause undesired operation.

Warning (Part 15.21)

Changes or modifications not expressly approved by the party responsible for compliance could void the user's authority to operate the equipment.



Innovative Solutions For the Drive-Thru Industry

542 South Prairie Street
Bethalto, IL 62010

800.598.2370

Office: 618.377.2654 Fax: 618.377.1320
www.rftechno.com