



Revision: Dec, 2011

RAEMesh Radio User Manual (for RM2400, RM900, RM900A...)

RAE Systems Inc



Revision: Dec, 2011

Introduction

The RAEMesh Radio module offers a complete microcontroller/transceiver solution Containing all hardware features necessary for development of a low data-rate, low-power wireless application. The primary components include an IEEE 802.15.4 compliant Zigbee-ready transceiver , a microcontroller, a 40-pin interface connector, a MMCS antenna connector,

This documentation describes the RAEMesh radio module hardware interface as well as RAE System's Command Interface.

Hardware

Specifications

Frequency Band	802.15.4 standard. RM2400:16 channels of operation in the 2.4GHz world wide ISM band. 5MHz channel spacing. RM900: 11 channels. 868, 906,908.....924MHz RM900A: 11 channels. 868, 906,908.....924MHz
Power	+3.3V \pm .3V from carrier board, 3.0V to 3.6V from battery pack
Interfaces	40-pin surface-mount 2x20 1.27mm pitch
RF	250kbps OQPSK Direct Sequence Spread Spectrum.
Dimensions	46.5 mm x 26 mm x 10 mm
Antenna Interface	50-Ohm MMCX female
Operating Temperature Range	-40°C to +85°C
Indicators	Two LEDs, one red, one blue (DS1, DS2)
Current Consumption	0.5 μ A Sleep 120 mA TX @ 18 dBm 25 mA RX / Idle
RF receive sensitivity	-100dBm at at 1% packet error rate for a 20 byte payload.
Data Rate	250 kbps
Antenna	Omnidirectional antenna, 3.5dBi max

Mechanical Size

Top View

Units: mm

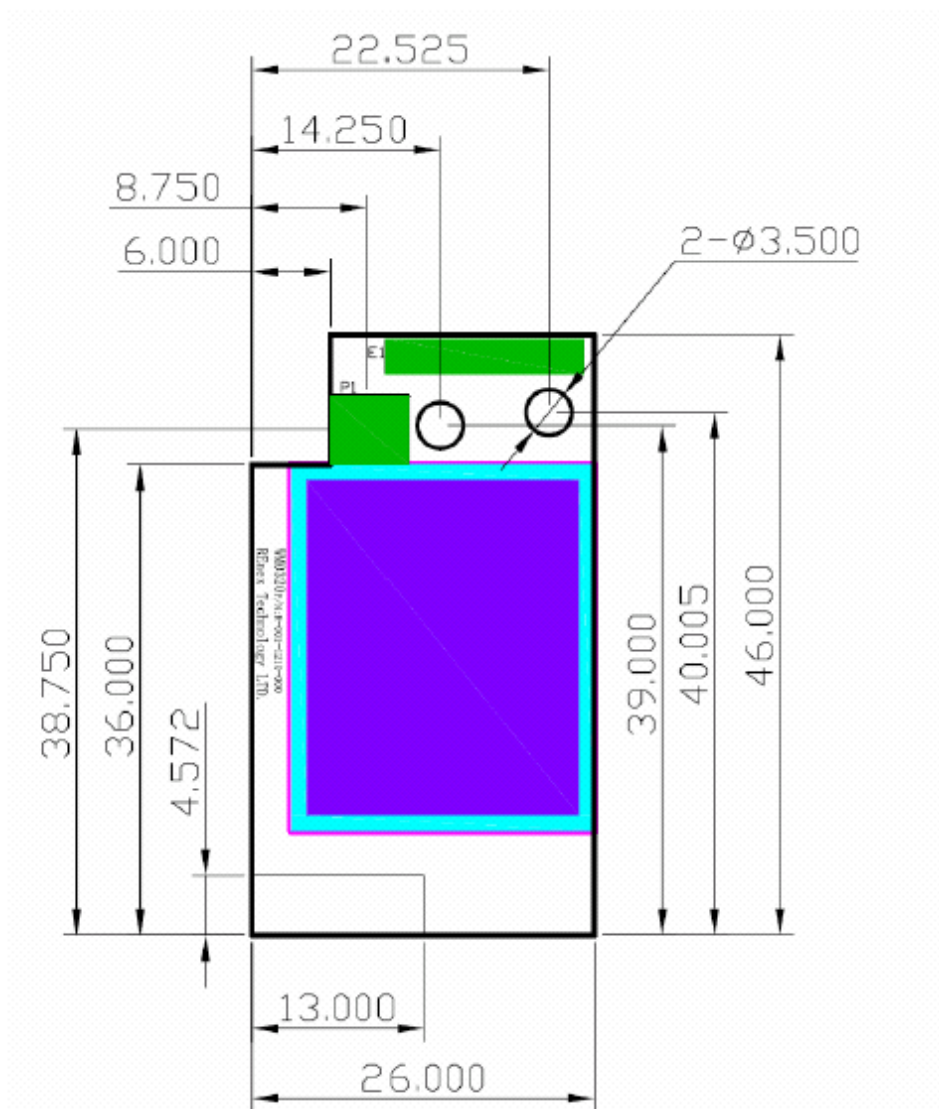

The height of the shielding box is 4.3mm from the PCB.

40 Pin header (1.27mm) is used for board to board connection. Corresponding mate connector can be JVE 22P8702-40M00B-01G-4.5

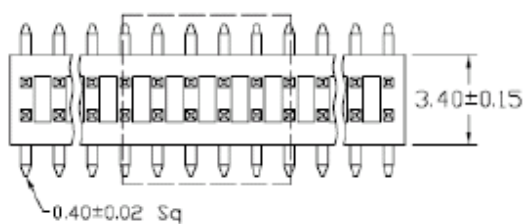



Revision: Dec, 2011

Pin Layout

Pin	Description	Pin	Description
1	DGND	2	DGND
3	nRESET	4	DGND
5	TXD1	6	TXD0/Bootload.
7	RXD1	8	RXD0
9	GPIO0	10	GPIO/LED2
11	GPIO1	12	GPIO/LED3
13	GPIO2	14	GPIO/LED4
15	GPIO3	16	GPIO/LED5
17	TEMP_E/GPIO4	18	GPIO/PS_CS
19	WakeUp/GPIO5	20	GPIO/PS_FRAME
21	BUZZER/GPIO6	22	+3.3V
23	GPIO7/PS_DIR	24	AGND
25	BUTTON0/GPIO8	26	AREF
27	BUTTON1/GPIO9	28	ATEMP/ADC1
29	GPIO10	30	ADC2
31	RF_SO	32	TCK
33	RF_SI	34	TMS
35	RF_CK	36	TDO
37	SFD	38	TDI
39	+3.3V	40	+3.3V



Revision: Dec, 2011

Firmware

The module is pre-loaded with the bootloader, which supports serial bootloading of firmware update. The module contains RAEMesh application and comply with the RAE System's RCS protocol. The module also has built-in RAEMesh Module Command Interface(RMCI).

This documentation is focused on the instruction on RMCI interface.

The RMCI command interface allows customer to easily access to low level mesh functionality without pain to develop the firmware. The module can be configured to a GTW to hook up to a getaway or just a stand alone regular full function node or a Sleepy reduce function node.

Make sure to configure the module to right mode before using.

Quick Start

UART

Via the TXD1 and RXD1 pins the command interpreter can be accessed. The RCM can buffer up to 128 bytes of incoming data in a software FIFO buffer and uses XON/XOFF flow control. See the datasheet of the Atmel ATmega1281 for more information about the build-in UART.

Connect Pin5 (TXD1) and Pin7 (RXD1) to the customer board. Use the following settings for serial port.

RTR and STD: 19200bps, 8N1.

GTW: 38400bps, 8N1.

Data Packet

RCM will transmit any data in the {}, all data in the {} will be transparently sent out without radio's interpretation. **The maximum data packet is 50 bytes including {}.**

The data in the {} can be any characters including '{' '}' '[' ']' .

The interval between 2 data packets must be >200ms for RTR and GTW.

The interval between 2 data packets must be >1s for STD.

Wakeup

If the radio is set to STD mode, the Wakeup pin Pin19 (PE7) is used to make the radio asleep and wakeup. A constant high on this pin will let the radio go to the sleep mode and a low level signal on this pin will wake-up the radio.

The Radio sleep mode is the power save mode so the power consumption can be very low. (<40uA)

The Wakeup pin must be held up to 10ms before sending a data packet.

Power

Ground: Pin1, Pin2 and Pin4.

VCC: Pin39, Pin40. 3.0V or 3.3V

Radio consumes less than 100mW in normal RX/TX mode.

Radio consumes 600mW at TX and 100mW at RX for High power module

Heartbeat

Connect Pin12 to a LED for heartbeat indicator.

Reset

RST: Pin3 Active Low.



Revision: Dec, 2011

PC communication

Please has your serial port debug software installed on the PC. For example: `sscom32.exe`
Microsoft Hyper Terminal is not recommended for this application because it is not good to send characters and commands in Hex.

Base on correct setting and connection, you will see following display on your screen when power is applied.

GTW:

```
[%A ]RAEMESH-II RM900A 16MHz  
FwVer:V1.02b on Sep 28 2011 09:52:14  
Stack: BC1.10.0  
Type: Coordinator/Gateway  
Band: 915  
EUI: 0001002400001005  
Channel: 0x10  
TxPwr: Medium  
PanId: 0x03E5
```

RTR:

```
[%A-]RAEMESH-II RM900A 16MHz  
FwVer:V1.02b on Sep 28 2011 09:52:14  
Stack: BC1.10.0  
Type: FFD/Router  
Band: 915  
EUI: 0001002400001005  
Channel: 0x10  
TxPwr: Medium  
PanId: 0x03E5
```

STD

```
[%A-]RAEMESH-II RM900A 16MHz  
FwVer:V1.02b on Sep 28 2011 09:52:14  
Stack: BC1.10.0  
Type: RFD Sleep Sensor  
Band: 915  
EUI: 0001002400001005  
Channel: 0x10  
TxPwr: Medium  
PanId: 0x03E5
```



RAEMesh2 Module Command Interface

Format:

	SOP	Length	Command Code	Command Data	EOP
Byte:	1	1	1	0~n	1

Byte Number	Name	Comment
0	SOP	Radio Protocol beginning of packet. This is always '[' (0x5B)
1	Length	Total length of packet + 0x20, include '[' and ']'. Total length of packet + 0x20, include '[' and ']'.
2	Command Code	0x20 ~ 0xFF. Excluding:0x5A~0x5F and 0x7A~0x7F. 0xF0~0xFF are reserved for common commands. Even for packet sent from SDTE or RDTE to RCM. Odd for packet response from RCM to SDTE or RDTE.
3	Command Data	Hex
...	...	
N+3	EOP	Radio protocol end of packet.. This is always ']'(0x5D)

The minimum length for one packet is 4 bytes long. The Length is 0x20 based. E.g. the total length of a packet without command data is 4, the Length byte is $0x20 + 4 = 0x24$.

The SDTE or RDTE always initiate the communication with Radio module (RRCM, SRCM). Radio Module responses to the command it received.

The Command Code for packet sent from SDTE or RDTE to Radio module is even, the response from Radio module to SDTE or RDTE is 1 higher than the command code.

Command Data can be empty.

No command for 0x5A~0x5F and 0x7A~0x7F.

A Section 0xF0~0xFF is reserved for common commands such as help, Version etc.

Caution: the maximum packet length from SOP to EOP is 64 bytes.

Notes:

1. All commands response in **50ms**
2. Check RCM's information when turn on the radio. Command: 5B 24 60 5D.
3. Wait at least **5s** for RCM to finish the initialization after power on.
4. Check the network status of the STD before sending the data for first time. Command: 5B 24 20 5D.
5. It is recommend to add 1s interval between 2 data packets for STD. Check 0x5b 24 27 5d for sending acknowledge with successfully. There is no ACK for transmission failed.
6. For STD, if there is no network, the RCM will automatically wake up every 10 minute to search for a new network. It can be interrupted any time. RCM will keep in asleep if it has joined a network.



Command List of RMCI

5B 24 20 5D = Get network status
5B 24 50 5D = Join or form network by scan.

5B xx 26 dd dd 7B 7D 5D = Send message in unicast

5B 24 2A 5D = Get Radio Type
5B 24 3A 5D = Get device application type
5B 24 60 5D = Get Radio's UID, channel, PANID
5B 24 6C 5D = Get Application's UID, channel, PANID
5B 24 68 5D = Get parent Network ID
5B 24 7B 5D = Get Last Hop Link Quality (LQI)
5B 24 40 5D = Get reset reason.
5B 24 4C 5D = GET_FWVERSION

5B 24 30 5D = Enable GTW function
5B 24 32 5D = Enable RTR function
5B 24 46 5D = Enable STD function

5B 24 4A 5D = Restore the radio to factory setting

5B 25 34 xx 5D = Set channel number, xx(0x00 for EURO, 0x01-0x0A for North America, 0x0B-0x1A for ISM)
5B 25 A0 xx 5D = Enable receiver while idle on STD.
5B 24 A2 5D = Get receiver on/off on STD.
5B 25 A4 xx 5D = Set region.
5B 24 A6 5D = Get region.
5B 25 3C xx 5D = Set Tx power, xx(0xFF for maximum, 0x80 for middle, and 0x00 for minimum)
5B 26 44 xx xx 5D = Set PanId, xxxx(0x0000-0x03E7)
5B 2C 4E xx xx xx xx xx xx xx 5D = Set MAC/UID address
5B 25 AC xx 5D = SET_CMDBATCH
5B 24 AE 5D = GET_CMDBATCH
5B 25 B0 XX 5D = SET_PMTJOIN, permit or forbid any joining attempt.
5B 24 B2 5D = GET_PMTJOIN

5B 24 3E 5D = Leave current network
5B 26 42 xx xx 5D = Set routing discovery interval
5B 24 52 5d = Get routing discovery interval

5B 24 38 5D = Report node's position
5B 24 48 5D = Soft reset
5B 24 56 5D = Access into bootloader

5B 25 FE xx 5D = Set print debug info, xx(00-disable; 01-enable)



• **Command Sets**

Command Name	Effect Area	CMD Code	CMD Data (bytes)	Response CMD Code	Response CMD Data(Bytes)	Description
NETWORK_STATUS Use on: GTW RTR STD	Both	0x20	None	0x21	STATUS(1)	Return the radio's network status 0x00: NO NETWORK 0x02: JOINED NETWORK. Host controller or instrument should call it periodically with certain duty cycle to check the network status.
SEND_MSG_UNICAST Use on: GTW RTR STD	RM	0x26	DestNwkID(2) RCS Pack(x)	0x27	None	Send message in unicast mode. NwkAddr: Network address Message must in RCS format.
GET_MODULE_TYPE Use on: GTW RTR STD	Both	0x2A	None	0x2B	Type(1)	Return the radio's type. Type: 0: Bluetooth 1: coRE3-433MHz 2: coRE3-868MHz 3: coRE3-915MHz 4: ZcoRE3-2400 5: UART to Ethernet 6: UART to RS485 7: RM2420 8: RM900 9: Reserve 10: RM2400 11: coRE1-433MHz 12: coRE1-868MHz 13: coRE1-915MHz 14: coRE2-433MHz 15: coRE2-868MHz 16: coRE2-915MHz 17: coRE6-2.4GHz
GTW_ENABLE Use on: GTW RTR STD	Both	0x30	None	0x31	None	Set the radio as a GTW so that the radio can be use on a Gateway device. Baud rate change to 38400 8N1 Reset automatically.
RTR_ENABLE Use on: GTW RTR STD	Both	0x32	None	0x33	None	Set radio to RTR. Always on and has router function. Baud rate change to 19200 8N1 Reset automatically.
CHG_RRCM_CHANNEL Use on: GTW RTR	Both	0x34	Channel Number (1)	0x35	None	Requests change radio channel to specified channel. Meanwhile, specified channel should be compliance with radio region setting.



STD						<p>0x00 for RM900 if region is BAND_868_EU.</p> <p>0x01 to 0x0A total 10 channels for RM900 if region is BAND_915_NA.</p> <p>0x0B to 0x1A total 16 channels for RM2400 if region is BAND_2400_ISM.</p> <p>If channel number is not compliance with radio region, do not return response CMD. Reset automatically.</p>
RPT_LOCATION Use on: GTW RTR STD	Both	0x38	None	0x39	None	Print node's network information in ASCII.
GET_APPTYPE Use on: GTW RTR STD	Both	0x3A	None	0x3B	AppType(1)	Get application type. AppType: 1 – GTW; 2 – RTR; 3 – Reserved; 4 – STD; 5 – Reserved; other - invalid
SET_TX_POWER Use on: GTW RTR STD	Both	0x3C	TxPwr(1)	0x3D	None	Set modem transmission power level. For RAEMeshII 0xFF – maximum level, 0x80 – middle level, 0x00 – minimum level, For RAEMesh Power setting from 0xE3(-25dBm) to 0xFF(0dBm). Reset automatically.
LEAVE_NETWORK Use on: GTW RTR STD	Both	0x3E	None	0x3F	None	Leave the current network.
RST_REASON Use on: GTW RTR STD	Both	0x40	None	0x41	Reason(1)	Below just list RAEMeshII reset reason, 0x00 = UNKNOW, 0x01 = RESET_EXTERNAL, 0x02 = RESET_POWERON_, 0x03 = RESET_WDT, 0x04 = RESET_BROWNOUT, 0x05 = RESET_JTAG, 0x06 = RESET_WARM,



SET_ROUTEINTERMII VAL Use On: RTR		0x42	Type(1) Interval(1)	0x43	None	Type(1) Bit7~bit2: reverse, Bit1: enable route discovery immediately if set, Bit0: set route discovery interval with the value of Interval(1). Interval(1) Routing interval, range is from 10 to 240, unit is second. If RTR/Router lost connection with its next hop, it should route discovery periodically as per the value of Interval(1).
CHG_PAN_ID Use on: GTW RTR STD	Both	0x44	PanID:(2) XXXX	0x45	None	Change GTW Pan ID into XXXX. From 0x0001 to 0x03E7(1-999) Reset automatically.
STD_ENABLE Use on: GTW RTR STD	Both	0x46	None	0x47	None	Put a node into STD. Interrupt enable and active low. Baud rate change to 19200 8N1 Reset automatically.
SOFT_RESET Use on: GTW RTR STD	Both	0x48	None	0x49	None	Perform soft reset. Reset automatically.
FACTORY_RST Use on: GTW RTR STD	Both	0x4A	None	0x4B	None	Restore the RCM to factory defaults. PanId: 0x03E7, Device Type: STD. For RM2400, channel is 0x0f and txpower is -6dBm and 17dBm through power amplifier. For RM900, TBD Debug print is disable. STD receiver is disable. GTW or RTR permit joining is enable. Reset automatically.
SET_RECEIVER Use on: STD	RMII	0xA0	00 - Disable 01 - Enable	0xA1	None	Enable or disable STD's receiver. STD should receive data packet from parent if enable receiver; STD should use poll to request data packet from parent if disable receiver. Reset automatically.

For Internal Use Only



GET_RECEIVER Use on: STD	RAEMeshII	0xA2	None	0xA3	Status(1)	Return STD receiver's status, 00 – Disable 01 - Enable
SET_REGION Use on: GTW RTR STD	RAEMeshII	0xA4	Region(1)	0xA5	None	Region(1) BAND_868_EU = 0x01, BAND_915_NA = 0x04, BAND_2400_ISM = 0x08, For RM2400, this command is useless because RM2400 always work on BAND_2400_ISM. For RM900, default channel is 0x00 if set region to BAND_868_EU; default channel is 0x06 if set region to BAND_915_NA. Reset automatically.
GET_REGION Use on: GTW RTR STD	RAEMeshII	0xA6	None	0xA7	Region(1)	Get modem setting of region.
SET_UID Use on: GTW RTR STD	RAEMeshII	0x4E	UID(8)	0x4F	None	Set radio's UID(MAC address). Note: The last two bytes must not set to 0x0000, 0xFFFF-0xFFFF Reset automatically.
JOIN_FORM_NETWORK Use on: GTW RTR STD	Both	0x50	None	0x51	None	GTW: Form a network using customized PANID to allow the other nodes to join. RTR/STD: Search the network using customized PANID and try to join the network.
GET_ROUTEINTERVAL Use on: RTR	RAEMeshII	0x52	None	0x53	Interval(1)	Return the routing interval.
GET_NODE_INFORMATION Use on: GTW RTR STD	Both	0x60	None	0x61	UID(8) Channel(1) Power(1) PAN ID(2)	Get the node information: UID, Channel, Txpower level,, PAN ID,
GET_APPLICATION_INFORMATION Use on: GTW RTR STD	Both	0x6C	None	0x6D	UID(8) Channel(1) Power(1) PAN ID(2)	Get the application information: UID, Channel, Power, PAN ID. If the network is not connected, the GET_NODE_INFORMATION will return wrong information, and then use this to get what we set.
GET_PARENT_ID Use on: RTR STD	Both	0x68	None	0x69	Parent radio ID(8)	0x00 00 00 00 00 00 00 00 means that STD or RTR's parent is coordinator/gateway. 0x00 00 00 00 00 00 mm nn means STD or RTR's parent is a RTR which short address is mm

For Internal Use Only



						nn. 0x00 00 00 00 00 00 ff fe means that STD or RTR do not have parent.
LAST_HOP_RSSI Use on: RTR STD	Both	0x7B	None	0x7C	RSSI(1)	Get RSSI percent, the higher, the better. Best: 240 Worst:0 RTR get next hop rssi; STD get parent rssi.
SET_DEBUG_PRINT Use on: GTW RTR STD	Both	0xFE	00,Disable 01,Enable	0xFF	None	Set display debug information enable/disable. The default setting is disabled.
GET_FWVERSION Use on: GTW RTR STD	Both	0x4C	None	0x4D	Fw Version and Build Time[30]	Return fw version and build time, for example [BMv1.00 Feb 14 2011 10:11:11] , this mean fw version is V1.00 and build is on Feb 14 2011 10:11:11.
SET_CMDBATCH Use on: GTW RTR STD	RAEMeshII	0xAC	00, Disable 01, Enable	0xAD	None	Enable or disable command batch function. If enable, modem will not reset automatically after change panid, channel, power, eui, region , receiver and join permission. They will take effect after reset manually. Batch function will disable after reset.
GET_CMDBATCH Use on: GTW RTR STD	RAEMeshII	0xAE	None	0xAF	00, Disable 01, Enable	Return command batch configuration.
SET_BOOTLOADER Use on: GTW RTR STD	Both	0x56	None	0x57	None	Make modem into bootloader mode and wait for new app image.
SET_PMTJOIN Use on: GTW	RMII	0xB0	0x01, enable; 0x00, disable	0xB1	None	This command can disable or enable Coordinator or RTR's join network permission. If modem disable joining permission, it forbid any modem joining attempt.
GET_PMTJOIN Use on: GTW	RMII	0xb2	None	0xb3	0x01, enable; 0x00, disable	Return status that whether modem permit joining network attempt from RTR or STD

Caution: RCM will save corresponding command data of AT command into its persist data server if this command cause "Reset automatically", it will take effect after reset.

For Internal Use Only



- **RMII Command Classification**

There are a lot of RMCI command set in this manual, different application need different command, below is a table that which command must have, which are recommend and which are optional.

Table 2 Command Classification

ITEM	MUST HAVE	RECOMMENED	OPTIONAL
CMDS	GET_APPTYPE NETWORK_STATUS GET_APPNODE_INFO GTW_ENABLE RTR_ENABLE STD_ENABLE SET_PANID JOIN_FORM_NETWORK LEAVE_THE_NETWORK SET_CHANNEL GET_PARENT_ID LAST_HOP_RSSI	GET_MODEM_TYPE SET_TXPOWER RST_REASON SEND_MSG_UNI SET_UID SET_REGION SET_RECEIVER	FACTORY_RST SET_DEBUG_PRINT



Procedure for Radio Core Setting:

A. Configure

Software: AVRUSB V2.0.2.231

Hardware: AVRUSB Programmer and RAEMeshII Dev board.

1. Make sure the correct hardware selected

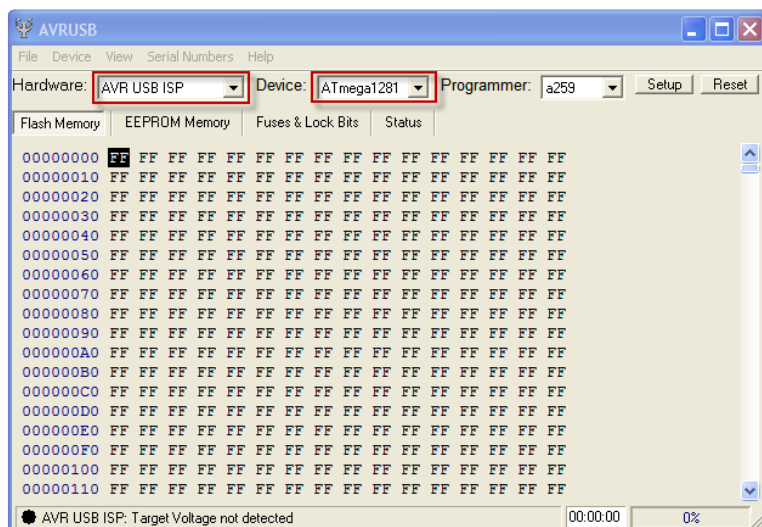

2. Click “Reset”. If a green label is at bottom of AVRUSB framework, go to next step.

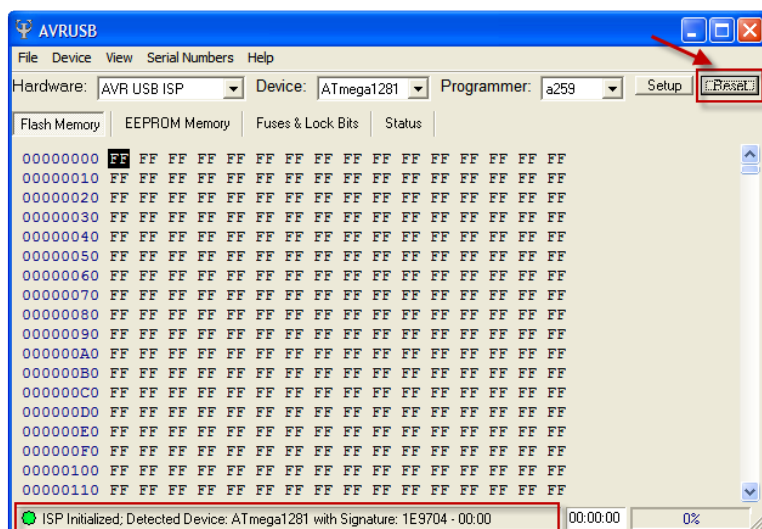



3. Erase target MCU

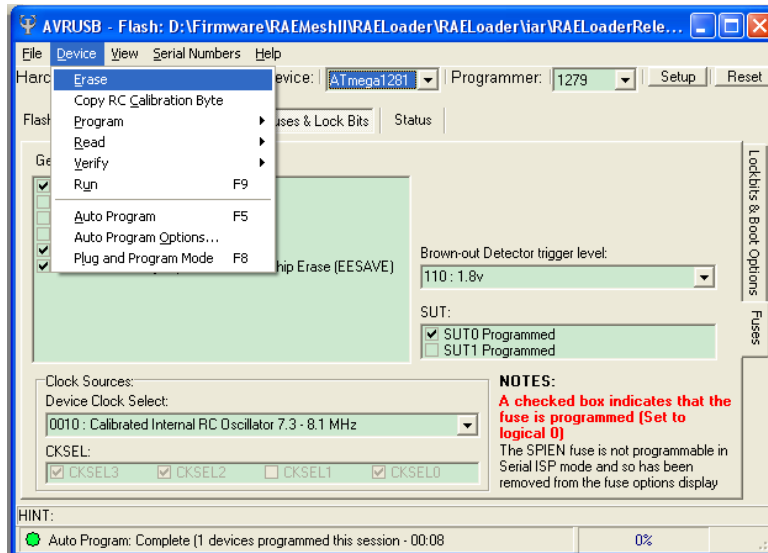

4. Read out current fuse setting

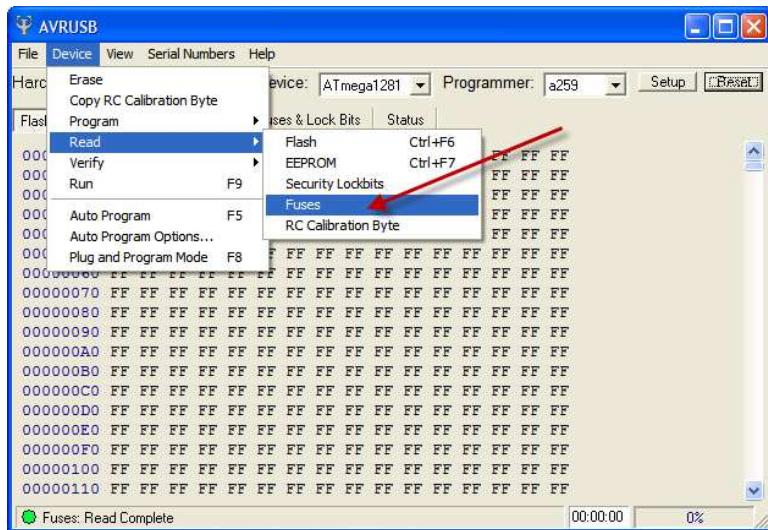



5. Check the following setting.

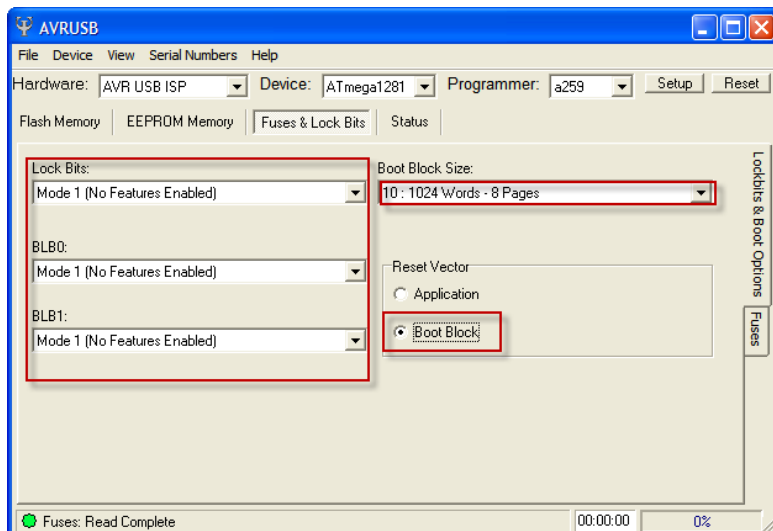
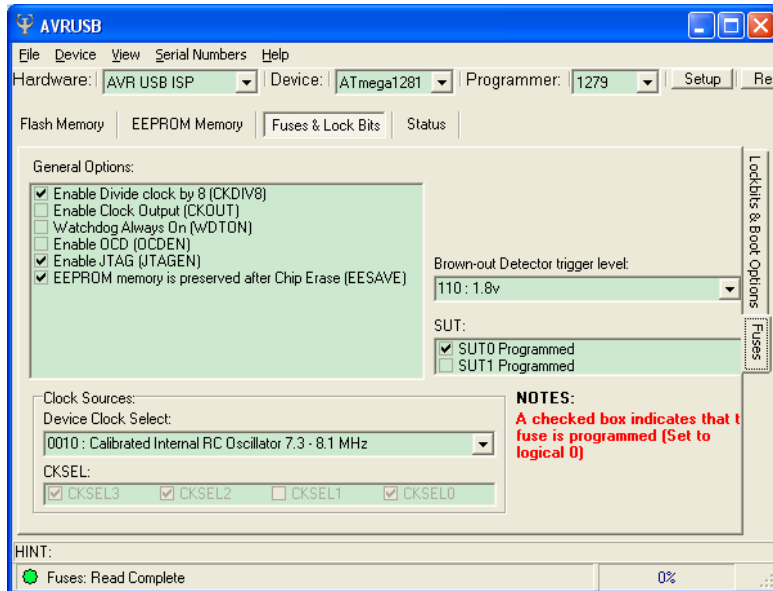



6. Write back Fuse setting if any changes made, make sure program successfully.

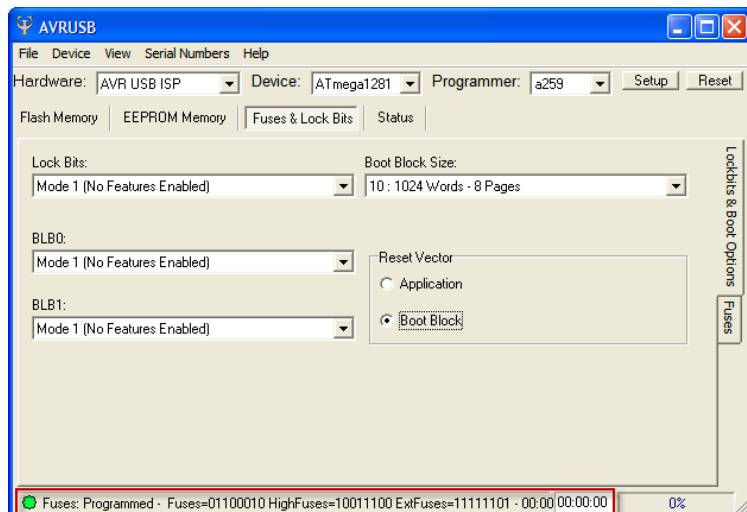

B. Firmware Upgrade

1. Select firmware file, *.srec
2. Select correct com port
3. Click “Program”, then Reset RAEMesh2 module in 30 seconds
4. Waiting for program successful

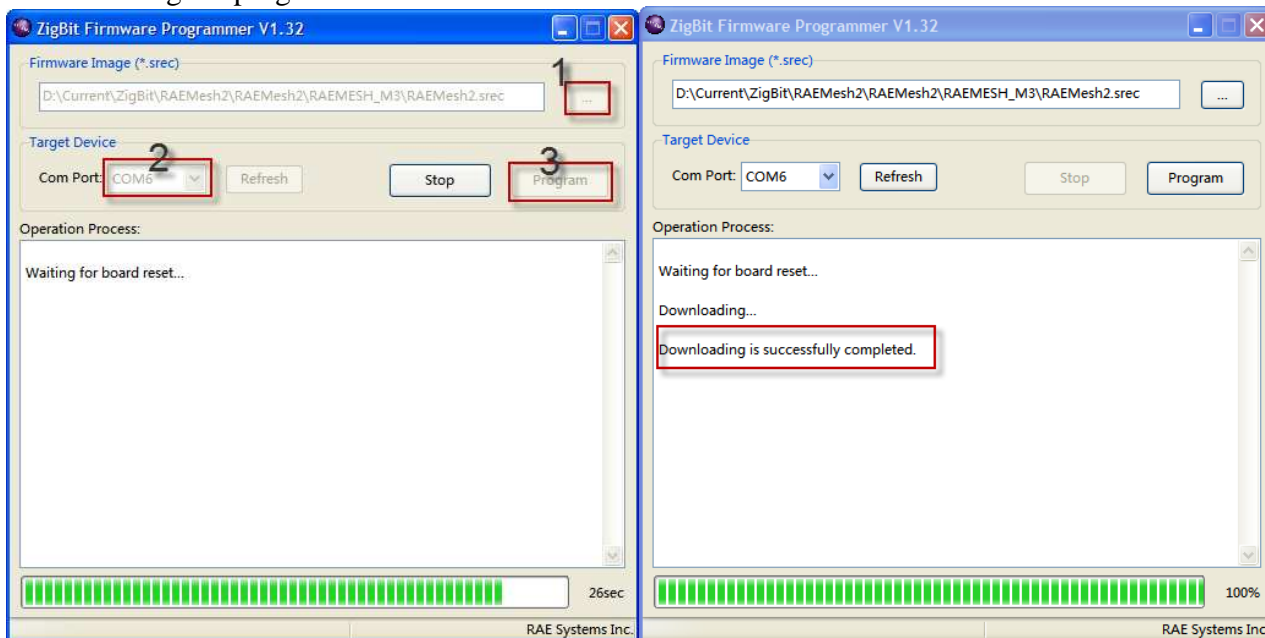



Terms

GTW: A RTR used for gateway. Only one GTW per network.

RTR: Full Function Device. Sensor node with routing ability. RTR requires line power all time.

STD: Reduce Function Device. A Sleeping node can only talk to a RTR or GTW. Can not relay the message. Can be a battery powered device.

RCM :Radio Communications Module

RDTE: Reader Data Terminal Equipment.

RMCI: RAEMesh Module Command Interface.

SDTE : Sensor Data Terminal Equipment.

Reference

Atmel: www.atmel.com

FCC: www.fcc.gov

Zigbee Alliance: www.zigbee.org

Disclaimer

Product and Company names and logos referenced may either be trademarks or registered trademarks of their respective companies. We reserve the right to make modifications and/or improvements without prior notification. All information is correct at time of issue. RAE Systems does not convey any license under its patent rights or assume any responsibility for the use of the described product.

Warnings

FCC Notifications:

Compliance Statement (Part 15.19)

This device complies with part 15 of the FCC rules. Operation is subject to the following two conditions:

1. This device may not cause harmful interference received, including interference that may cause undesired operation.
2. This device must accept any interference received, including interference that may cause undesired operation.

Warning (Part 15.21)

Changes or modifications not expressly approved by the party responsible for compliance could void the user's authority to operate the equipment.

This device must be operated as supplied by Raesystems. Any changes or modifications made to the device can be jeopardize, but there is one exception. The radio's antenna can be replaced as long as the specification of the antenna matches the original.

Information for the OEMs and integrators

This device is intended for OEM integrators only. Please see the full Grant of Equipment document for restrictions. This device must be operated and used with a locally approved access point.



Label information to the End User by the OEM or integrator

If the FCC ID of this module is not visible when it is installed inside another device, then the outside of the device into which the module is installed must be labeled with "Contains FCC ID: SU3RM900A" in a visible area.

This equipment has been tested and found to comply with the limits for a Class B digital device, pursuant to part 15 of the FCC Rules. These limits are designed to provide reasonable protection against harmful interference in a residential installation. This equipment generates uses and can radiate radio frequency energy and, if not installed and used in accordance with the instructions, may cause harmful interference to radio communications. However, there is no guarantee that interference will not occur in a particular installation. If this equipment does cause harmful interference to radio or television reception, which can be determined by turning the equipment off and on, the user is encouraged to try to correct the interference by one or more of the following measures:

- Reorient or relocate the receiving antenna.
- Increase the separation between the equipment and receiver.
- Connect the equipment into an outlet on a circuit different from that to which the receiver is connected.
- Consult the dealer or an experienced radio/TV technician for help.