

# RAK831 Lora Gateway

## Datasheet V1.2

© 2016 Rakwireless all rights reserved .

Mentioned in this document , the actual company and product names, trademarks are their respective owners.

After update the new version, this document without prior notice.

# Content

1. Introduction.....	3
1.1 Key Features .....	4
1.2 Applications .....	4
2. Module Package.....	5
2.1 Pinout Description .....	5
2.2 Module Dimensions.....	6
3. Module Overview .....	7
3.1 SX1301 .....	7
3.1.1 Block Diagram.....	8
3.1.2 IF8 LORA channel .....	8
3.1.3 IF0 to IF7 LORA channels .....	9
3.3 External Module Connector.....	9
3.3.1 SPI .....	9
3.3.2 GPS PPS .....	9
3.3.3 Digital IOs .....	9
4. LoRa Systems, Network Approach.....	10
4.1 Overview .....	10
4.2 Firmware.....	11
5. Electrical Characteristics& Timing specifications.....	11
5.1 Absolute Maximum Ratings .....	11
5.2 Global Electrical Characteristics .....	11
5.3 SPI Interface Characteristics.....	12
5.4 RF Characteristics.....	12
5.4.1 Transmitter RF Characteristics .....	12
5.4.2 Receiver RF Characteristics.....	13
5.5. RF Key Components .....	13
5.6. RF antenna interface .....	14
6. Contact information .....	15
7. Appendix .....	15
8. Change Note.....	16

# 1. Introduction

The concentrator module RAK831 is targeted for a huge variety of applications like Smart Metering, IoT and M2M applications. It is a multi- channel high performance Transmitter/receiver module designed to receive several LoRa packets simultaneously using different spreading factors on multiple channels. The concentrator module RAK831 can be integrated into a gateway as a complete RF front end of this gateway. It provides the possibility to enable robust communication between a LoRa gateway and a huge amount of LoRa end-nodes spread over a wide range of distance. The RAK831 needs a host system for proper operation.

This is a ideal modular products to help you realize the whole Lora system development. With the USB-SPI converter module FT2232, you can quickly to make the software development in your PC. But also, you can integrate the concentrator module to your production product to realize the Lora gateway function. This is very economic way to address for a huge variety of applications like Smart Grid, Intelligent Farm, intelligent Farm and Other IoT applications.

The RAK831 needs a host system like Raspberry Pi or WisAP (OpenWRT based) or WisCam for proper operation . The host processor can be a PC or MCU that will be connected to RAK831 via USB or SPI

RAK831 is using as a gateway, communication based on lorawan protocol requires. 64 channels utilizing LoRa 125 kHz BW, starting at 902.3 MHz and incrementing linearly by 200 kHz to 914.9 MHz, and 8 channels utilizing LoRa 500 kHz BW, starting at 903.0 MHz and incrementing linearly by 1.6 MHz to 914.2 MHz were used for receiving. 8 channels utilizing LoRa 500 kHz BW, starting at 923.3 MHz and incrementing linearly by 600 kHz to 927.5 MHz were used for transmitting.

RAK831 is able to receive up to 8 LoRa packets simultaneously sent with different spreading factors on different channels. This unique capability allows to implement innovative network architectures advantageous over other short range systems:

End-point nodes (e.g. sensor nodes) can change frequency with each transmission in a random pattern. This provides vast improvement of the system robustness in terms of interferer immunity and radio channel diversity.

## 1.1 Key Features

- Compact size 80.0 x 50.0 x 5.0mm
- LoRa™ modulation technology
- Frequency band 923.3-927.5MHz
- Orthogonal spreading factors
- Sensitivity down to -142.5 dBm
- Maximum link budget 162 dB
- SPI interface
- SX1301 base band processor
- Emulates 49 x LoRa demodulators
- 12 parallel demodulation paths
- 2 x SX1257 Tx/Rx front-ends High frequency
- 2 x SX1255 Tx/Rx front-ends low frequency
- Supply voltage 5 V
- RF interface optimized to 50
- Output power level up to 11 dBm
- GPS receiver (optional)
- Range up to 15 km (Line of Sight)
- Range of several km in urban environment
- Status LEDs
- HAL is available from  
[https://github.com/RAKWireless/RAK831\\_LoRaGateway](https://github.com/RAKWireless/RAK831_LoRaGateway)

## 1.2 Applications

- Smart Metering
- Wireless Star Networks
- Home-, Building-, Industrial automation
- Remote Control
- Wireless Sensors
- M2M, IoT
- Wireless Alarm and Security Systems
- ...

## 2. Module Package

In the following the RAK831 module package is described. This description includes the RAK831 pinout as well as the modules dimensions.



### 2.1 Pinout Description

The RAK831 provides headers at the bottom side, which have a pitch of 2.54 mm. The description of the pins is given by below Table .

Pin	Name	Type	Description
1	+5V	POWER	+5V Supply Voltage
2			
3	GND	GND	GND
4	LNA_EN_A	Input	SX1301 Radio C Sample Valid
5	GND	GND	GPS Module LDO:Enable Pin
6	GND	GND	GND
7	RADIO_EN_A	Input	SX1257_A_EN
8	PA_G8	Input	PA GAIN 0
9	RADIO_EN_B	Input	SX1257_B_EN

10	PA_G16	Input	PA GAIN 1
11	PA_EN_A	Input	PA EN
12	GND	GND	GND
13	RADIO_RST	RST	SX1257_A_B RESET
14	GND	GND	GND
15	CSN	SPI	SX1301 SPI_NSS
16	MOSI	SPI	SX1301 SPI_MOSI
17	MISO	SPI	SX1301 SPI_MISO
18	SCK	SPI	SX1301 SPI_CLK
19	RESET	RST	SX1301 RESET
20	GPIO0	GPIO	SX1301 GPIO
21	GPIO1	GPIO	SX1301 GPIO
22	GPIO2	GPIO	SX1301 GPIO
23	GPIO3	GPIO	SX1301 GPIO
24	GPIO4	GPIO	SX1301 GPIO

## 2.2 Module Dimensions

The outer dimensions of the RAK831 are given by 80.0 x 50.0 mm ± 0.2 mm. The RAK831 provide four drills for screwing the PCB to another unit each with a drill diameter of 3 mm.

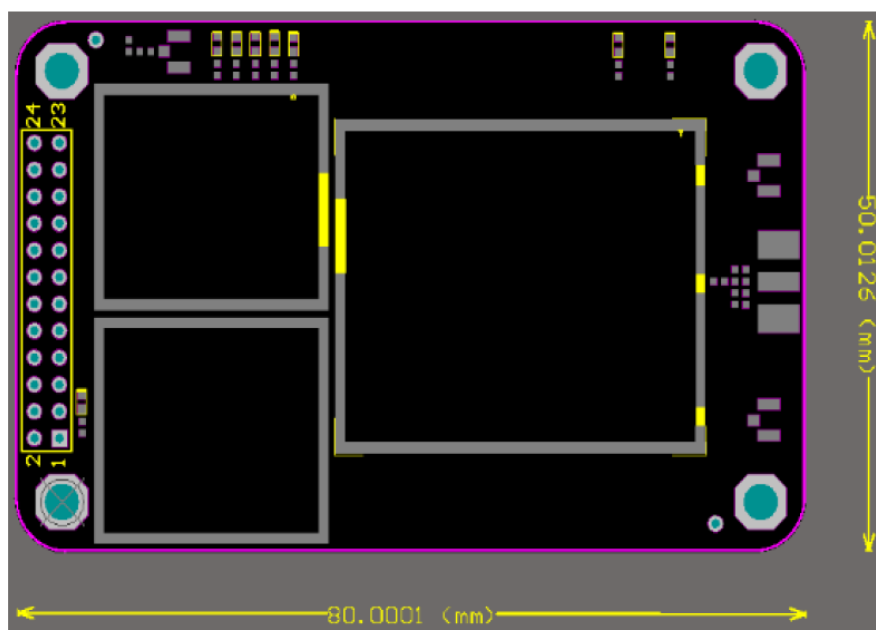

# 3.Module Overview

The Concentrator Module is currently available in one versions with SPI interface.

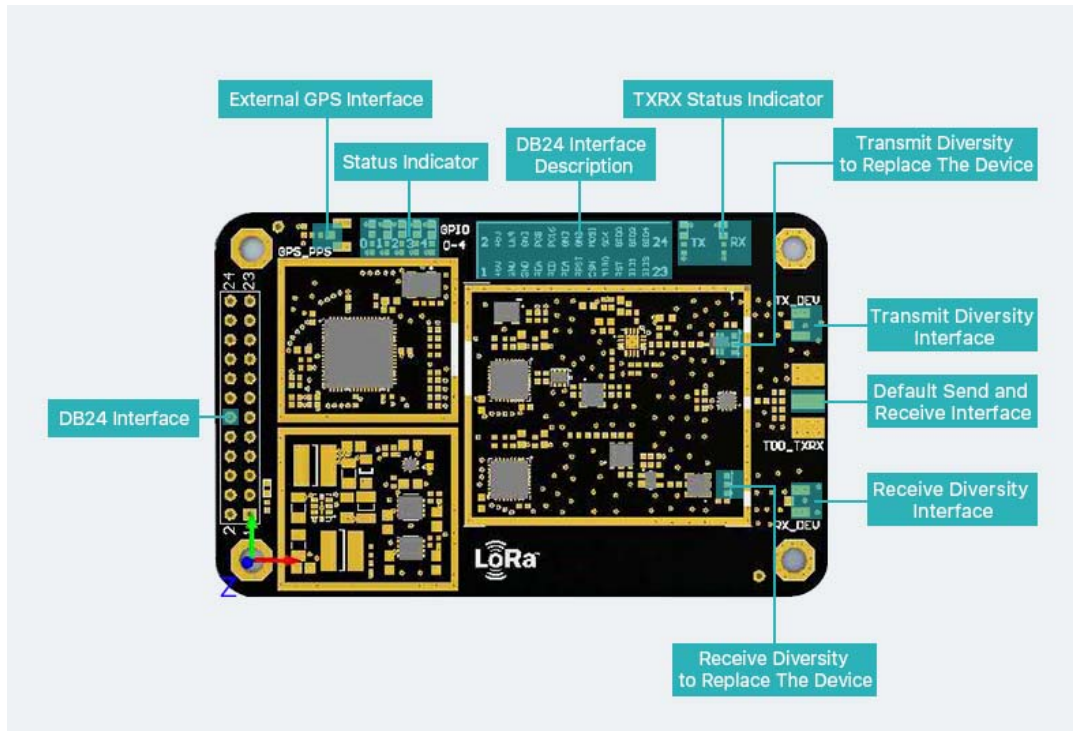

## 3.1 SX1301

The RAK831 includes Semtech's SX1301 which is a digital baseband chip including a massive digital signal processing engine specifically designed to offer breakthrough gateway capabilities in the ISM bands worldwide. It integrates the LoRa concentrator IP.

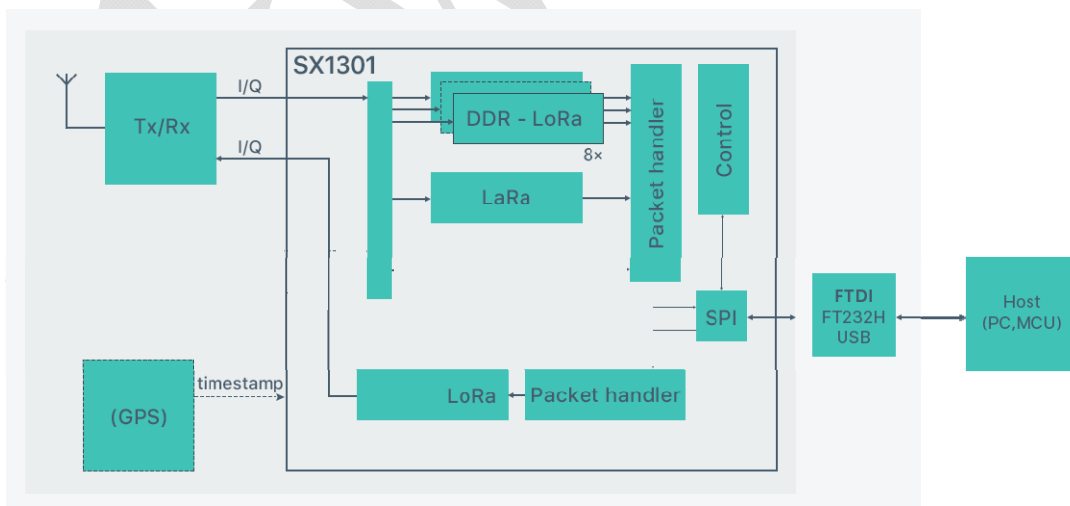

The SX1301 is a smart baseband processor for long range ISM communication. In the receiver part, it receives I and Q digitized bit stream for one or two receivers (SX1257), demodulates these signals using several demodulators, adapting the demodulators settings to the received signal and stores the received demodulated packets in a FIFO to be retrieved from a host system (PC, MCU). In the transmitter part, the packets are modulated using a programmable LoRa modulator and sent to one transmitter (SX1257). Received packets can be time-stamped using a GPS PPS input.

The SX1301 has an internal control block that receives microcode from the host system (PC, MCU). The microcode is provided by Semtech as a binary file to load into the SX1301 at power-on (see Semtech application support for more information).

The control of the SX1301 by the host system (PC, MCU) is made using a Hardware Abstraction Layer (HAL). The Hardware Abstraction Layer source code is provided by Semtech and can be adapted by the host system developers.

It is highly recommended to fully re-use the latest HAL as provided by Semtech on <https://github.com/Lora-net>.

### 3.1.1 Block Diagram

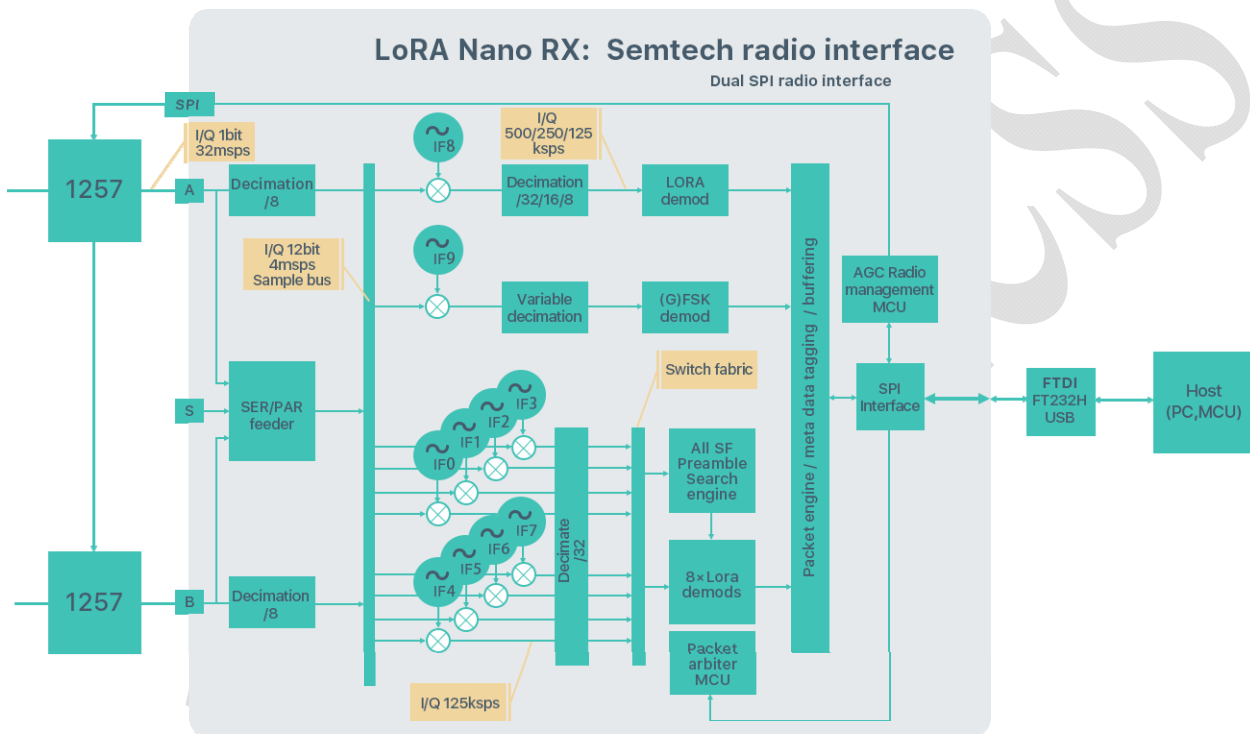

The SX1301 digital baseband chip contains 10 programmable reception paths. Those paths have differentiated levels of programmability and allow different use cases. It is important to understand the differences between those demodulation paths to make the best possible use from the system.

### 3.1.2 IF8 LORA channel

This channel is connected to one SX1257 using any arbitrary intermediate frequency within the allowed range. This channel is LoRa only. The demodulation bandwidth can be configured to be 125, 250 or 500 kHz. The data rate can be configured to any of the LoRa available data rates (SF7 to SF12) but, as opposed to IF0 to IF7, only the configured data rate will be demodulated. This channel is intended to serve as a high speed backhaul link to other gateways or infrastructure equipment. This demodulation path is compatible with the signal transmitted by the SX1272 and SX1276 chip family.



### 3.1.3 IF0 to IF7 LORA channels

Those channels are connected to one SX1257. The channel bandwidth is 125 kHz and cannot be modified or configured. Each channel IF frequency can be individually configured. On each of those channels any data rate can be received without prior configuration.

Several packets using different data rates (different spreading factors) may be demodulated simultaneously even on the same channel. Those channels are intended to be used for a massive asynchronous star network of 10000's of sensor nodes. Each sensor may use a random channel (amongst IF0 to IF7) and a different data rate for any transmission.

Sensors located near the gateway will typically use the highest possible data rate in the fixed 125 kHz channel bandwidth (e.g. 6 kbit/s) while sensors located far away will use a lower data rate down to 300 bit/s (minimum LoRa data rate in a 125 kHz channel).

The SX1301 digital baseband chip scans the 8 channels (IF0 to IF7) for preambles of all data rates at all times.

The chip is able to demodulate simultaneously up to 8 packets. Any combination of spreading factor and intermediate frequency for up to 8 packets is possible (e.g. one SF7 packet on IF0, one SF12 packet on IF7 and one SF9 packet on IF1 simultaneously).

The SX1301 can detect simultaneously preambles corresponding to all data rates on all IF0 to IF7 channels. However, it cannot demodulate more than 8 packets simultaneously. This is because the SX1301 architecture separates the preamble detection and signal acquisition task from the demodulation process. The number of simultaneously demodulated packets (in this case 8) is an arbitrary system parameter and may be set to other values for a customer specific circuit.

The unique multi data-rate multi-channel demodulation capacity SF7 to SF12 and of channels IF0 to IF7 allows innovative network architectures to be implemented.

## 3.3 External Module Connector

### 3.3.1 SPI

The connector on the bottom side provides an SPI connection, which allows direct access to the Sx1301 SPI interface. This gives the target system the possibility to use existing SPI interfaces to communicate.

After powering up RAK831, it is required to reset SX1301 via PIN 13. If the Hal driver from Github is used this functionality is already implemented.

### 3.3.2 GPS PPS

In case of available PPS signals in the target system, it is possible to connect this available signal to the appropriate pin at the connector.

### 3.3.3 Digital IOs

There are five GPIOs of the Sx1301 available, which gives the user some possibilities to get information about the system status. These pins are the same, as they are used for the LEDs on

the RAK831 .

As default setting the LEDs :

- 1) Backhaul packet
- 2) TX packet
- 3) RX Sensor packet
- 5) RX buffer not empty
- 6) Power

## 4.LoRa Systems, Network Approach

The use of LoRa technology can be distinguished in “Public” and “Private” networks. In both cases the usage of a concentrator module can be reasonable. Public networks are operator (e.g. telecom) managed networks whereas private networks are individually managed networks.

LoRa networks are typically star or multiple star networks where a gateway relays the packets between the end-nodes and a central network server. For private network approaches the server can also be implemented on the gateway host.

Due to the possible high range the connection between end-nodes and the concentrator RAK831 is always a direct link. There are no repeaters or routers within a LoRa network.

Depending on the used spreading factor and signal bandwidth different data rates<sup>1</sup> (0.3 kbps to ~22 kbps) and sensitivities down to -142.5 dBm are possible. Spreading factor and signal bandwidth are a trade-off between data rate and communication range.

### 4.1 Overview

The RAK831 is able to receive on different frequency channels at the same time and is able to demodulate the LoRa signal without knowledge of the used spreading factor of the sending node.

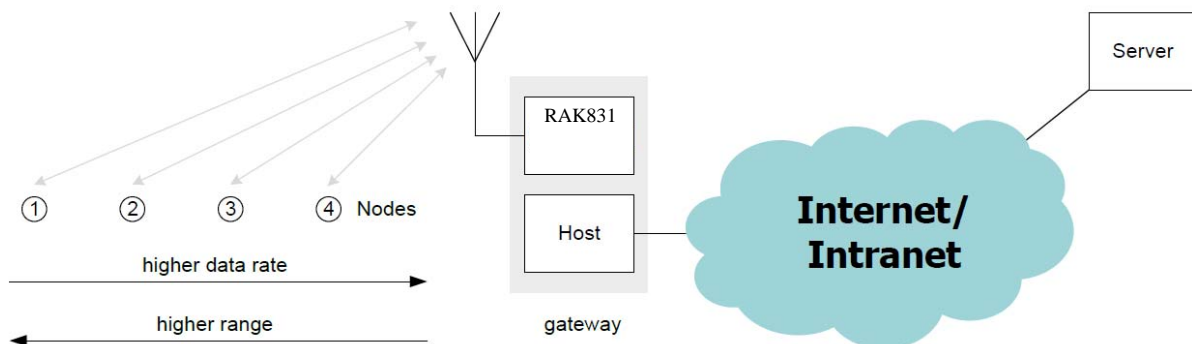

Due to the fact that the combination of spreading factors and signal bandwidths results in different data rates the use of “Dynamic Data-Rate Adaption” becomes possible. That means that LoRa nodes with high distances from the RAK831 must use higher spreading factors and therefore have a lower data rate. LoRa nodes which are closer to the concentrator can use lower spreading factors and therefore can increase their data rate.

Due to the fact that spreading factors are orthogonal and RAK831 supports up to 10 demodulations paths the channel capacity of a LoRa cell can be increased using RAK831 compared to conventional modulation techniques.

## 4.2 Firmware

The LoRa MAC specification is currently driven by the companies Semtech, IBM and Actility. Currently all available software, firmware and documentation can be found and downloaded from the open source project LoRa-net hosted on <https://github.com/Lora-net>

This project considers all parts that are needed to run a network based on LoRa technology. It includes the node firmware (several hardware platforms are supported), the gateway host software (HAL driver for SX1301, packet forwarder) and a server implementation.

It is highly recommended to fully re-use the latest HAL as provided by Semtech.

## 5. Electrical Characteristics & Timing specifications

In the following different electrical characteristics of the RAK831 are listed. Furthermore details and other parameter ranges are available on request.

**Note:** Stress exceeding of one or more of the limiting values listed under “Absolute Maximum Ratings” may cause permanent damage to the radio module.

### 5.1 Absolute Maximum Ratings

Parameter	Condition	Min	Typ.	Max	Unit
Supply Voltage(VDD)		-0.3	5.0	5.5	V
Operating Temperature		-40		+85	°C
RF Input Power				-15	dBm
Note:					

**Note:** With RF output power level above +15 dBm a minimum distance to a transmitter should be 1 m for avoiding too large input level.

### 5.2 Global Electrical Characteristics

Parameter	Condition	Min	Typ.	Max	Unit
Supply Voltage(VDD)		4.8	5.0	5.2	V
Current Consumption	RX Current		100		mA
	TX Current		80		
Note:					

T=25°C, VDD=5V(Typ.) if nothing else stated

Parameter	Condition	Min	Typ.	Max	Unit
Logic low input threshold(VIL)	“0”logic input			0.4	V
Logic high input threshold(VIH)	“1”logic input	2.9		3.3	V
Logic low output level(VOL)	“0”logic output,2mA sink			0.4	V
Logic high output level(VOH)	“1”logic output,2mA source	2.9		3.3	V
Note:					

## 5.3 SPI Interface Characteristics

T=25°C, VDD=5V(Typ.) if nothing else stated

Parameter	Condition	Min	Typ.	Max	Unit
SCK frequency				10	MHz
SCK high time		50			ns
SCK low time		50			ns
SCK rise time			5		ns
SCK fall time			5		ns
MOSI setup time	From MOSI change to SCK rising edge	10			ns
MOSI hold time	From SCK rising edge to MOSI change	20			ns
NSS setup time	From NSS falling edge to SCK rising edge	40			ns
NSS hold time	From SCK falling edge to NSS rising edge	40			ns
NSS high time between SPI accesses		40			ns
Note:					

## 5.4 RF Characteristics

### 5.4.1 Transmitter RF Characteristics

The RAK831 has an excellent transmitter performance. It is highly recommended, to use an optimized configuration for the power level configuration, which is part of the HAL. This results in a mean RF output power level and current consumption.

PA Control	DAC Control	MIX Control	DIG Gain	Nominal RF Power Level [dBm]
0	3	8	0	-5
0	3	9	0	-3
0	3	11	0	0
0	3	15	0	3
1	3	9	0	6
1	3	11	0	10
1	3	12	0	11

## 5.4.2 Receiver RF Characteristics

It is highly recommended, to use optimized RSSI calibration values, which is part of the HAL v3.1. For both, Radio 1 and 2, the RSSI-Offset should be set -169.0.

## 5.5. RF Key Components

This section introduce the key components in RAK831 and help the developer to utilize the system to realize own system level design.

### 1 ) LDO

The system power supply is provided by the external 5V DC power supply. SX1301 and related clock crystal is powered by Dual output LDO transformer outputs 1.8V and 3.3V in order to meet the normal working condition of SX1301. Other key components are powered by LDO transformer output 3.3V. To be aware of the system design of LDO's power supply enable is provided by the output GPIO of SX1301 as default. The connection method of pin enable should be kept same as Semtech official code. At the same time, System design also need to keep flexibility and all LDO enable should be connect to pin DB24. For this case, user can run the official reference code in this board, and also can change all external enable clock as they need for achieve the flexibility debugging.

### 2 ) Power amplifier

The Power amplifier choose RFMD LF Power Amplifier and built in two steps gain.

### 3 ) RF switch

The RF switch choose RFSW1012 which has advantage of high Isolation and low insertion loss. This chip handling the switch between Tx and Rx. The Control logic as below image. Specially need highlight that the pin of CTRL was controlled by SX1301's GPIO through output signal of LNA\_EN\_A, the Pin of EN was controlled by SX1301's GPIO through output signal of RADIO\_EN\_A. Simultaneously, it also can be controlled by external input signal through DB24.

State	V <sub>DD</sub>	CTRL	EN	RF Path
1	2.7V to 4.6V	V <sub>HIGH</sub>	V <sub>HIGH</sub>	ANT-RF2
2	2.7V to 4.6V	V <sub>LOW</sub>	V <sub>HIGH</sub>	ANT-RF1
Shutdown	2.7V to 4.6V	Don't Care	V <sub>LOW</sub>	Shutdown

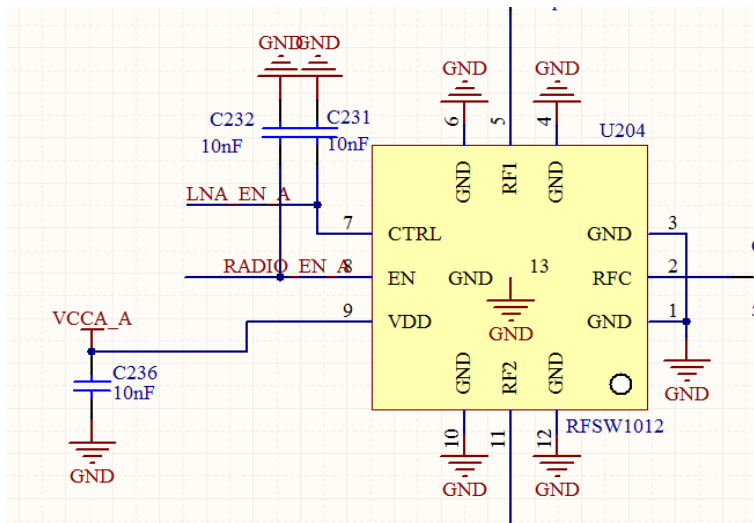

## 5.6. RF antenna interface

RAK831 provide three types of RF interface like SMA and other two IPEX connector. See the image as below for TDD\_TXRX, TX\_DEV, RX\_DEV. Consider the developer may require to support Tx/Rx simultaneously, therefore to make the compatible design. The Tx\_DEV is the Tx channel, need change the C224 to NC and C216 with CAP(56pf/0402) or 0ohm resistance when using as standalone channel. RX\_DEV is the Rx channel, need change C240 to NC and C244 with CAP(56pF/0402) or 0ohm resurance. The default design select the Path to TDD\_TXRX via RF switch and using external antenna.

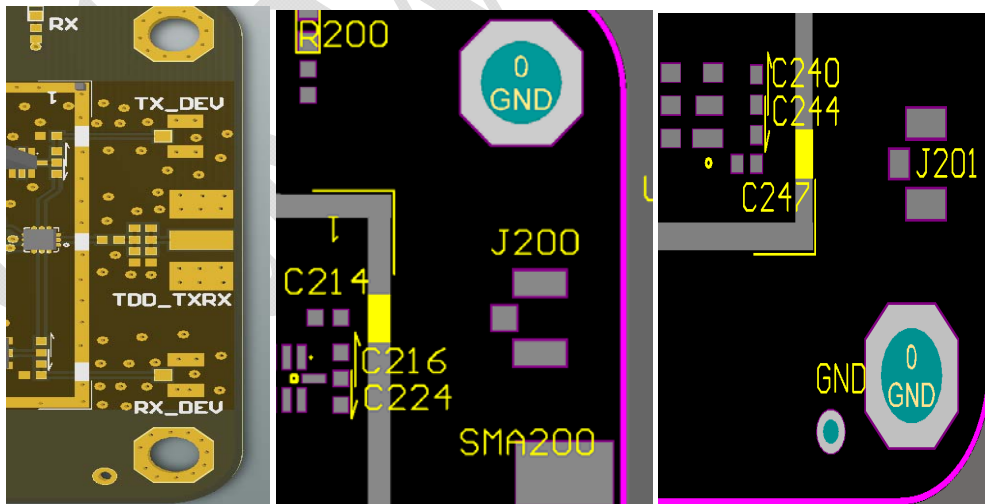

## 6. Contact information

### Shenzhen

FAE mailbox: ken.yu@rakwireless.com

Tel : 0755-86108311

Fax: 0755-86152201

Address: Room 1007, Hangsheng Technology Building, South Four Road, Science and Technology Park, Nanshan District, Shenzhen

## 7. Appendix

AFA	Adaptive Frequency Agility
BER	Bit Error Rate
BSC	Basic Spacing between Centers
GND	Ground
GPIO	General Purpose Input/Output
GPS	Global Positioning System
HAL	Hardware Abstraction Layer
IF	Intermediate Frequency
IoT	Internet of Things
ISM	Industrial, Scientific and Medical
LBT	Listen Before Talk
M2M	Machine to Machine
MAC	Medium Access Control
MCU	Microcontroller Unit
MPSSE	Multi-Protocol Synchronous Serial Engine (FTDI)
PCB	Printed Circuit Board
PPS	Pulse Per Second
RAM	Random Access Memory
RF	Radio Frequency
SMT	Surface Mounted Technology
SNR	Signal to Noise Ratio
SPI	Serial Peripheral Interface
TRX	Transceiver
USB	Universal Serial Bus

## 8.Change Note

Version	Date	Change
V1.0	2017-06-21	Draft
V1.1	2017-07-07	Modify picture
V1.2	2017-07-18	Modify the content

### FCC Warning

This device complies with part 15 of the FCC Rules. Operation is subject to the following two conditions:

(1) This device may not cause harmful interference, and (2) this device must accept any interference received, including interference that may cause undesired operation.

Any Changes or modifications not expressly approved by the party responsible for compliance could void the user's authority to operate the equipment.

When the module is installed in the host device, the FCC ID label must be visible through a window on the final device or it must be visible when an access panel, door or cover is easily removed. If not, a second label must be placed on the outside of the final device that contains the following text: — Contains FCC ID: 2AF6B-RAK831.

Maximum antenna gain allowed for use with this device is 2 dBi.

This module complies with FCC radiation exposure limits set forth for an uncontrolled environment .This equipment should be installed and operated with minimum distance 20 cm between the radiator& your body.