

RBH-RK86-D

Model Name:RBH-RK86-D,RBH-R86-D

V1.0

INSTALLATION HW 1.0

A. Package Content

Manufacture:RBH Access Technologies INC.

- Reader, Installation manual, Screw x 2, Anchor x 2
Torx screw x 1, Screwdriver x 1

■ Specification

- Dimension : 86 x 95 x 18 mm
- Voltage range : DC 9 ~ 24V
- Current : Max 200mA
- Wiegand range : up to 100M
- 485 range : up to 1000M
- Working temperature : - 20 °C ~ 70 °C
- Recommend shielded cable

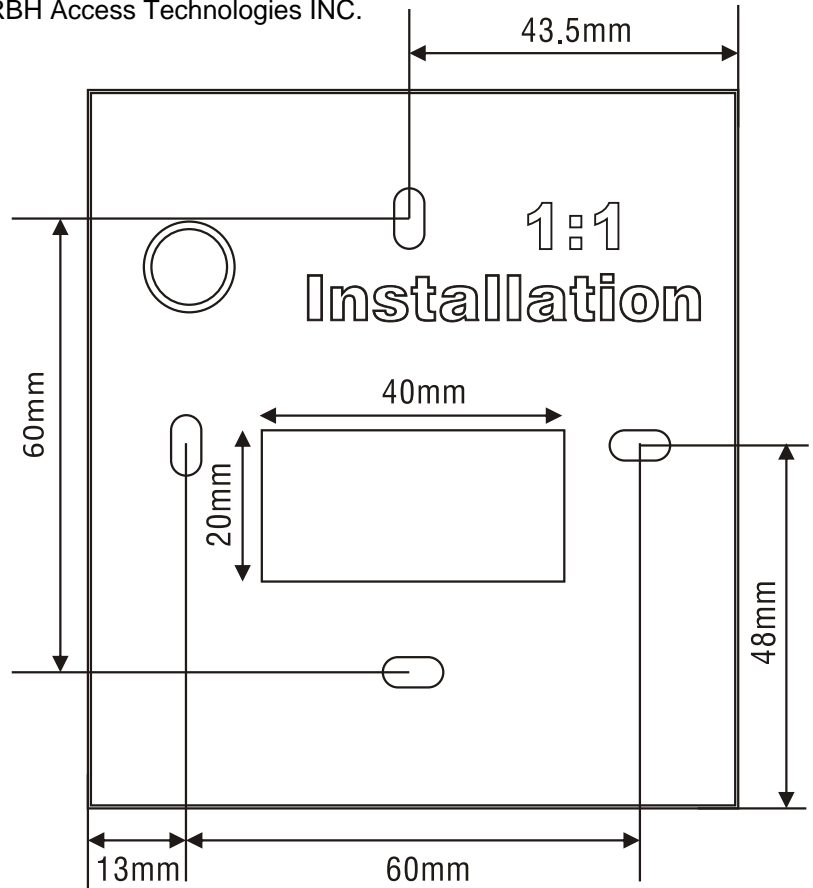
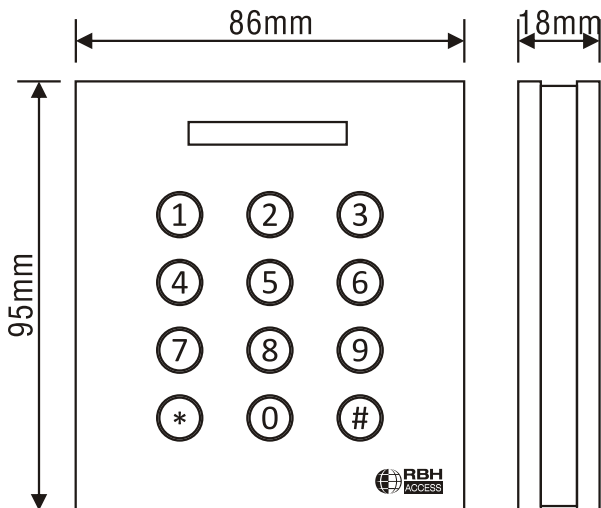

B. Installation Guide

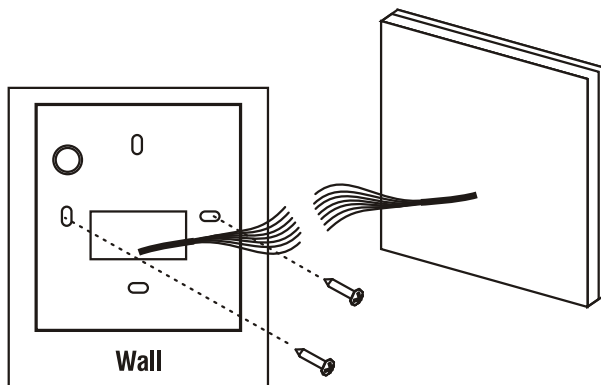

Install back case on the wall and connect cable

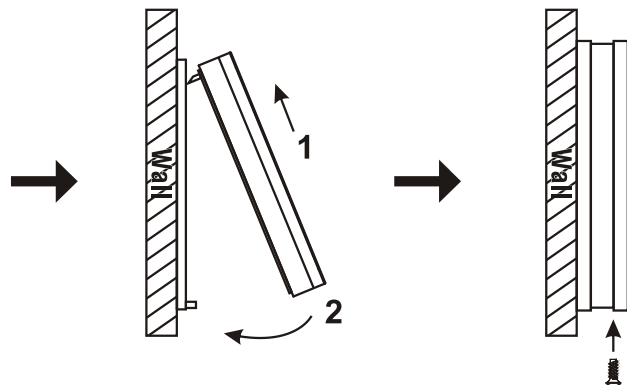

Install reader : clip top side first then press down ⚙️ Fasten torx screw

C. Cable Instruction

1	RED	VIN+ (Power Positive)	DC 9~24V
2	BLACK	GND (Power Negative)	
3	WHITE	DATA 1	Wiegand Cable
4	GREEN	DATA 0	
5	BLUE	Green LED Control / Low Potential	
6	YELLOW	Red LED + Buzzer Control / Low Potential	
7	ORANGE	485-	
8	BROWN	485+	

D. Connection Example

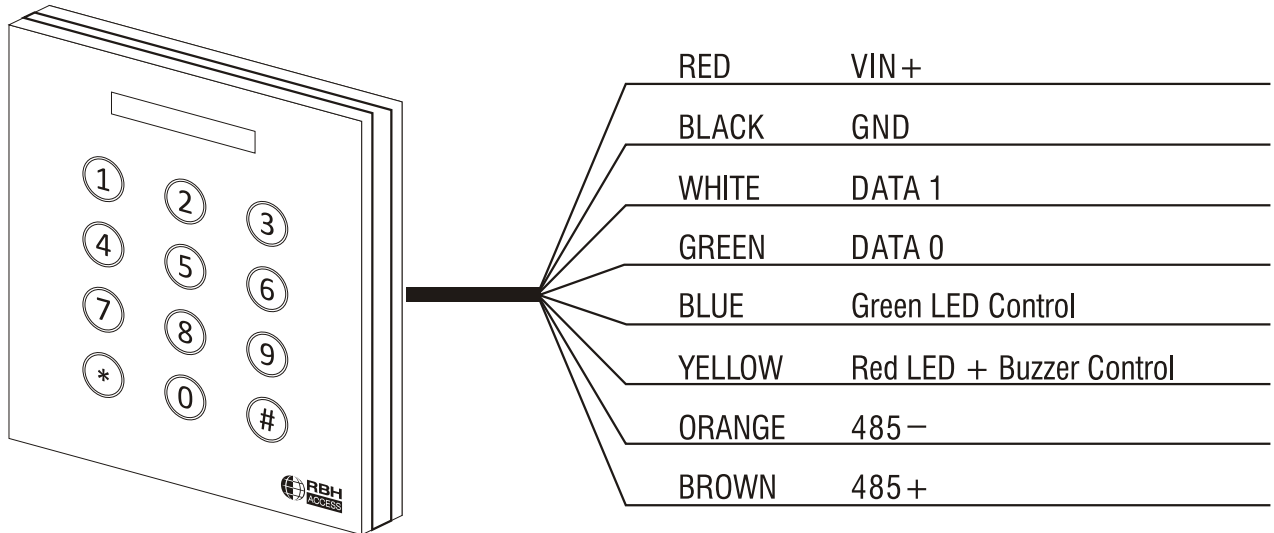

E. Buzzer & LED Instruction

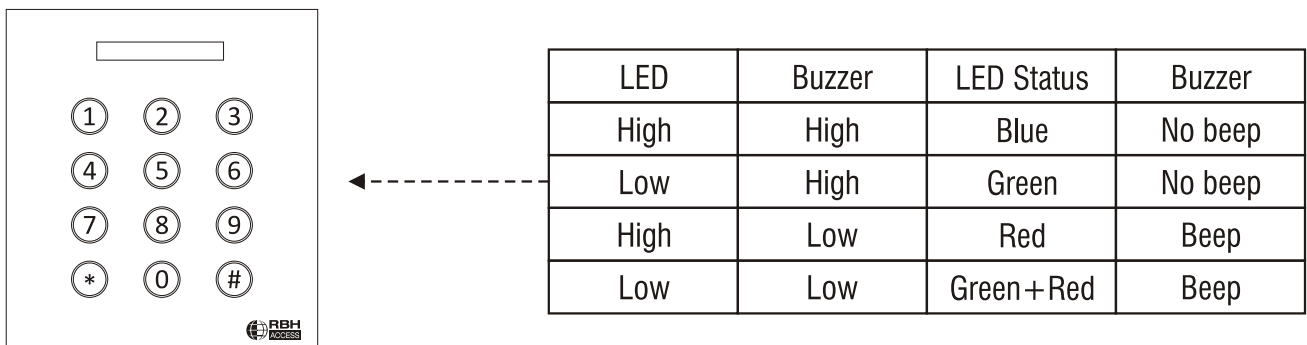

FCC Caution.

This device complies with part 15 of the FCC Rules. Operation is subject to the following two conditions:

- (1) This device may not cause harmful interference, and
- (2) this device must accept any interference received, including interference that may cause undesired operation.

Any Changes or modifications not expressly approved by the party responsible for compliance could void the user's authority to operate the equipment.

Note: This equipment has been tested and found to comply with the limits for a Class B digital device, pursuant to part 15 of the FCC Rules. These limits are designed to provide reasonable protection against harmful interference in a residential installation. This equipment generates uses and can radiate radio frequency energy and, if not installed and used in accordance with the instructions, may cause harmful interference to radio communications. However, there is no guarantee that interference will not occur in a particular installation. If this equipment does cause harmful interference to radio or television reception, which can be determined by turning the equipment off and on, the user is encouraged to try to correct the interference by one or more of the following measures:

- Reorient or relocate the receiving antenna.
- Increase the separation between the equipment and receiver.
- Connect the equipment into an outlet on a circuit different from that to which the receiver is connected.
- Consult the dealer or an experienced radio/TV technician for help.