

LCD TV Service Manual

For qualified service personnel only
Version 1.0

Model.
26LA33RQ

Changing Entertainment. Again.
www.rca.com



Chapter 1 Product Introduction

1.1 Basic Specifications

Model		26LA30RQ	26LA33RQ
Diagonal Display Size		26 inches	
Television System		American TV standard ATSC/NTSC system	
Channel Coverage		VHF: 2~13 UHF: 14~69 CATV: 1~135	
		Digital Terrestrial Broadcast (8VSB) : 2~69	
		Digital Cable (64/256QAM) : 1~135	
Temperature		Storage Temperature is -20°C~+60°C (-4°F~+140°F)	
		Operating Temperature is 0°C~+50°C (+32°F~+122°F)	
Humidity		Storage Humidity: Less than 85% RH (No condensation)	
		Operating Humidity: Less than 80% RH (No condensation)	
Power Supply		AC 110 V, 60Hz	
Connection Interface	RF input	Cable/Antenna x 1	
	Video input	AV x 1	
		Component x 1	
		HDMI x 4	
	Audio input	AV x 1	
		Component x 1	
		PC Audio In x 1	
	Audio output	Headphone x 1, Digital Audio Out x 1, AV x 1	
Graphic input	RGB 15pin x 1		
Resolution		1366 x 768	
Component/HDMI mode		480i, 480p, 720p, 1080i	
Dimensions	With stand	25.9" W x 18.7" H x 8.0"D	
	Without stand	25.9" W x 17.2" H x 4.3"D	
Weight	With stand	19.8LBS (9.0KGS)	
	Without stand	15.9LBS (7.2KGS)	
Power Consumption		less than 80W	

Chapter 1 Product Introduction

1.2 Product Function

Side Keypad Buttons

If you cannot locate your remote, you can use the side keypad buttons on your TV to operate many TV features.

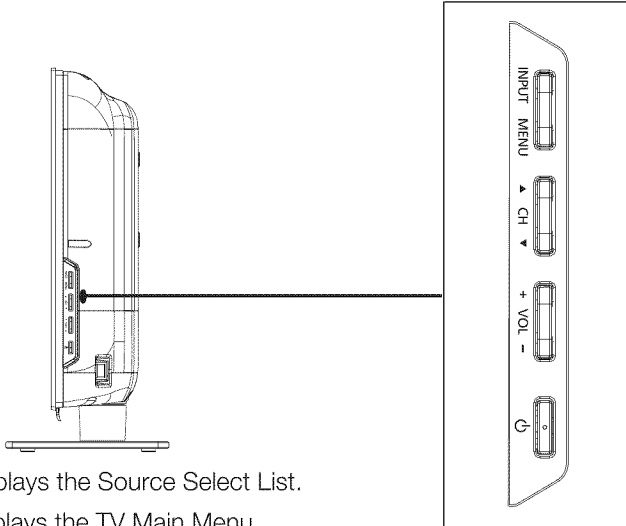

INPUT: Displays the Source Select List.

MENU: Displays the TV Main Menu.

CH ▲: Scans up through the channel list. In the TV menu system, it acts like the up arrow on the remote control and can be used to select menu options.

CH ▼: Scans down through the channel list. In the TV menu system, it acts like the down arrow on the remote control and can be used to select menu options.

VOL+: Increases the volume. In the TV menu system, it acts like the right arrow on the remote control and can be used to select menu options.

VOL-: Decreases the volume. In the TV menu system, it acts like the left arrow on the remote control and can be used to select menu options.

POWER (⏻): Turns the TV on and off.

Front Panel

Power/Standby Indicator: Blue and red dual-color LED. It shows red when the TV is turned off and blue when turned on.

Remote Control Sensor: Remote control IR sensor, which receives infrared ray sent by remote control.

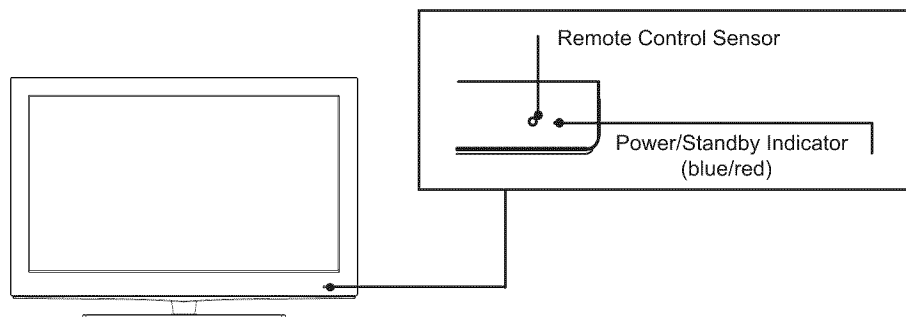

For more information about TV function, please refer to the User's Manual.

Chapter 1 Product Introduction

1.3 Connection Interface

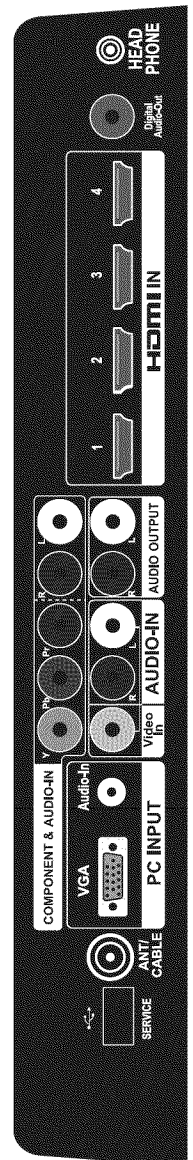
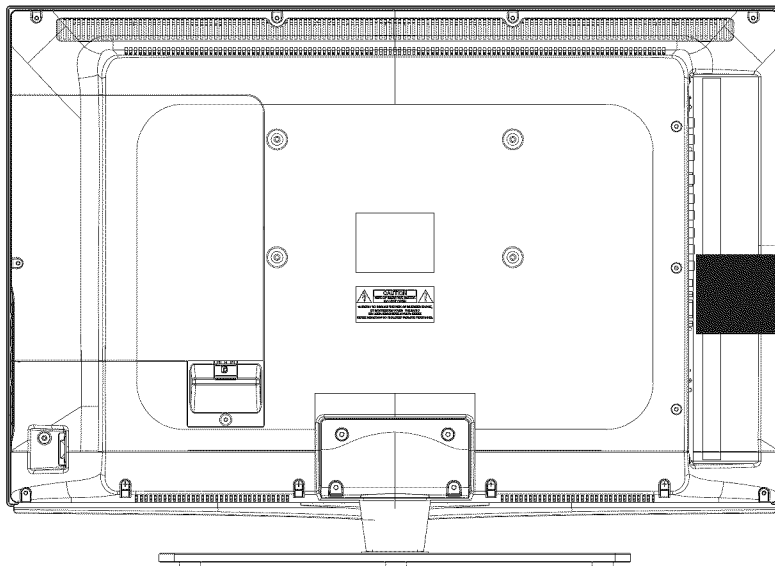

HEAD PHONE: Connect a 3.5mm headphone for personal audio.

Digital Audio-out: Connect a coaxial cable for digital audio output.

HDMI1, 2, 3, 4: (High-Definition Multimedia Interface) It provides an uncompressed digital connection that carries both video and audio data by way of an integrated mini-plug cable.

AUDIO OUTPUT L/R: Connect double-channel coaxial cables for analog audio output.

Note: •Digital Audio-out and AUDIO OUTPUT L/R are supposed to be connected to audio power amplifier, which provides smoother and more powerful sound performance.

AUDIO-IN L/R, Video In: Connect an AV device that has composite video jacks, such as a VCR or a DVD player. To access device connected to these jacks, press the INPUT button on your remote; then press the up/down arrow to select AV. Press the ENTER button at last to confirm.

• **AUDIO-IN L:** Left audio channel connection. The left audio connector is usually white.

For mono audio sources, be sure to use the left AUDIO INPUT.

• **AUDIO-IN R:** Right audio channel connection. The right audio connector is usually red.

COMPONENT Y/Pb/Pr: Connect a device that has component video jacks, such as a DVD player.

To access device connected to the Y/Pb/Pr jack, press the INPUT button on your remote; then press the up/down arrow to select Component. Press the ENTER button at last to confirm.

• **Y/Pb/Pr (Component Video):** They provide good picture quality because the video signal is separated into three components.

Use three video-grade or component video cables for the connection. When using Y/Pb/Pr, make sure you connect left and right audio cables to the Audio L and Audio R jacks.

PC INPUT VGA: Connect your computer or other device with a VGA output to this jack using a 15-pin, D-sub cable.

PC INPUT Audio-In: Use to obtain sound when a PC is connected to TV. Use 3.5mm stereo mini-pin cable to connect PC to TV.

ANT/CABLE: Connect to receive the signal from your antenna or cable via coaxial cable.

SERVICE: For service use only. Do not connect any device.

Chapter 2 LCD Panel Information

2.1 General Information

GENERAL DESCRIPTION

OVERVIEW

V260B2- P03 is a 26-inch TFT LCD cell with driver ICs and 1ch-LVDS interface. This module supports 1366 x 768 WXGA format and can display 16.7M colors (6-bit+Hi-FRC). The backlight unit is not built in

CHARACTERISTICS

CHARACTERISTICS ITEMS	SPECIFICATIONS
Screen Diagonal [in]	26.0
Pixels [lines]	1366*768
Active Area [mm]	575.769*323.712
Sub -Pixel Pitch [mm]	0.1405(H)*0.4215(V)
Pixel Arrangement	RGB vertical stripe
Weight [g]	TYP. 850
Physical Size [mm]	592(W) x 339.8(H) x 1.84(D) Typ.
Display Mode	TN, Normally White
Contrast Ratio	800:1 Typ. (Typical value measured at CMOs module)
Glass thickness (Array/CF) [mm]	0.7 / 0.7
Viewing Angle (CR>10)	+80/-80(H), +80/-70(V) Typ. (Typical value measured at CMOs module)
Color Chromaticity	R=0.653, 0.326 G=0.272, 0.587 B=0.150, 0.086 W=0.311, 0.320 *Please refer to color chromaticity on p.16
Cell Transparency [%]	7.0%Typ. (Typical value measured at CMOs module)
Polarizer (CF side)	Anti-Glare coating, 587.4(H) x 335.2(w). Hardness: 3H
Polarizer (TFT side)	587.4(H) x 335.2(w), Hardness: 3H

Chapter 3 Main Component

3.1 Inner Structure

Inside cabinet (front):

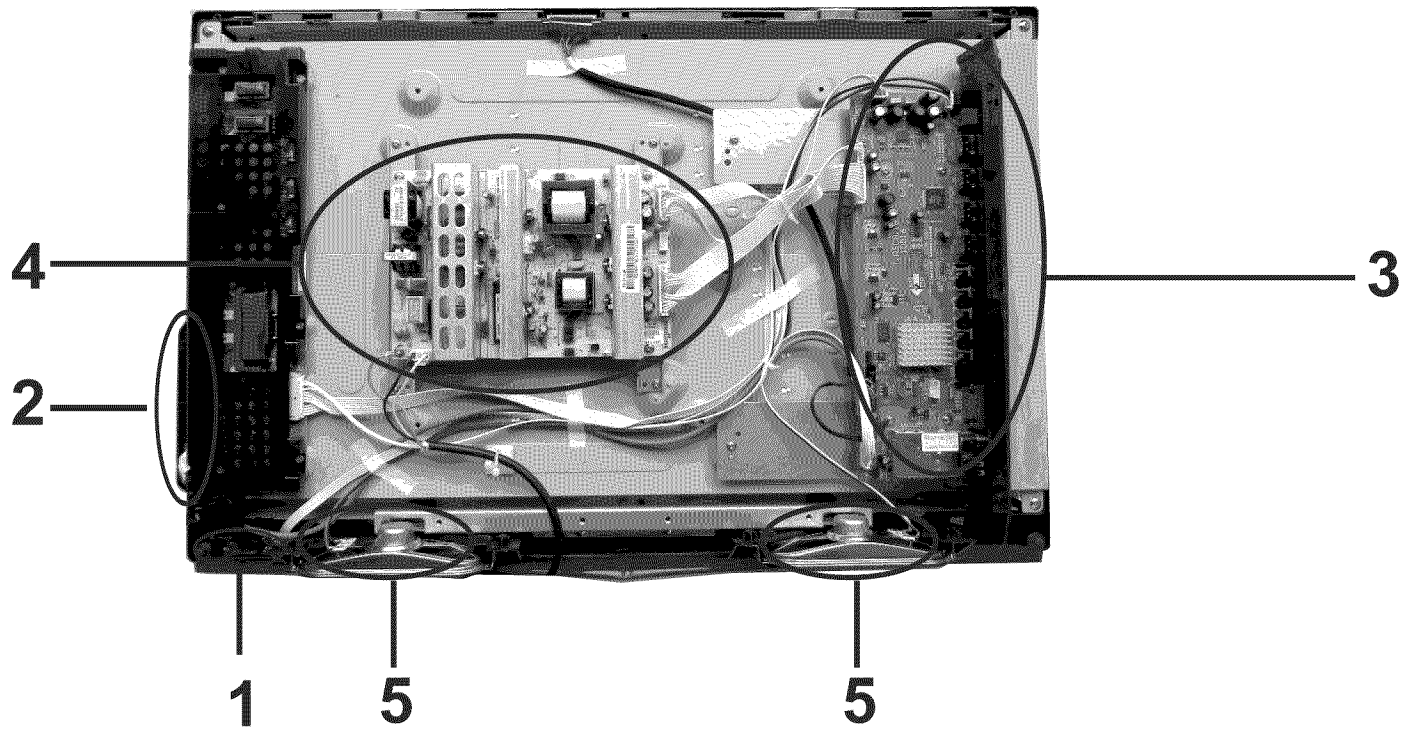

Chapter 3 Main Component

Item List

Item	Part No.	Part Name	Description	Note
1	RE3240E010	IR board	22F, 45 x 15 x 1.6 mm	(1)
2	RE0340E010	Key board	22F, 106.9 x 11.9 x 1.6 mm	(2)
3	RE01TC81XLNA0	Main board	T.RSC8.1X	
4	RE46QH1500	Power board	FSP150-4H01 150W	
5	RE261530458105	Speakers	80hm, 10W	

Note: (1,2) 22F and dimensions refer to the PCB board.

3.2 Main board connection

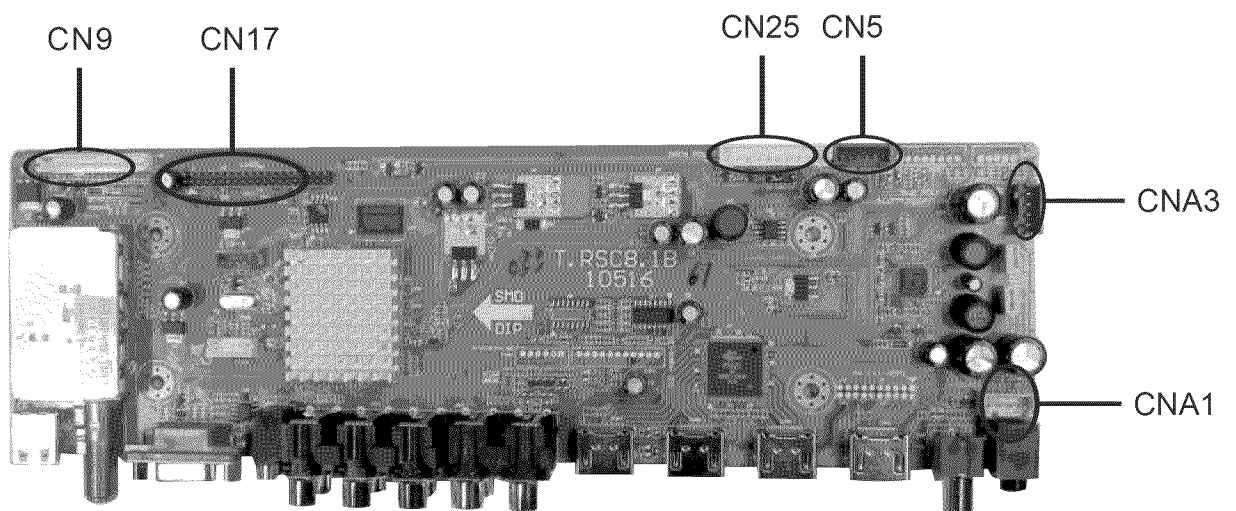

(Continued in next page.)

Chapter 3 Main Component

Jack List

Jack No.	Specification	Description	Connection	Note
CN25	10 Pin 2.54mm	Main power	To Power board	
CN17	2x20 Pin 2.0mm	LVDS interface	To LCD panel	
CN9	14 Pin 2.0mm	IR and keyboard jack	To IR board and keyboard	
CN5	6 Pin 2.0mm	Inverter Jack	To LCD panel inverter board	Backlight control
CNA3	4 Pin 2.54mm	Amplifier power supply jack	To power board	
CNA1	4 Pin 2.54mm	Speaker jack	To Speaker	

3.3 Power board connection

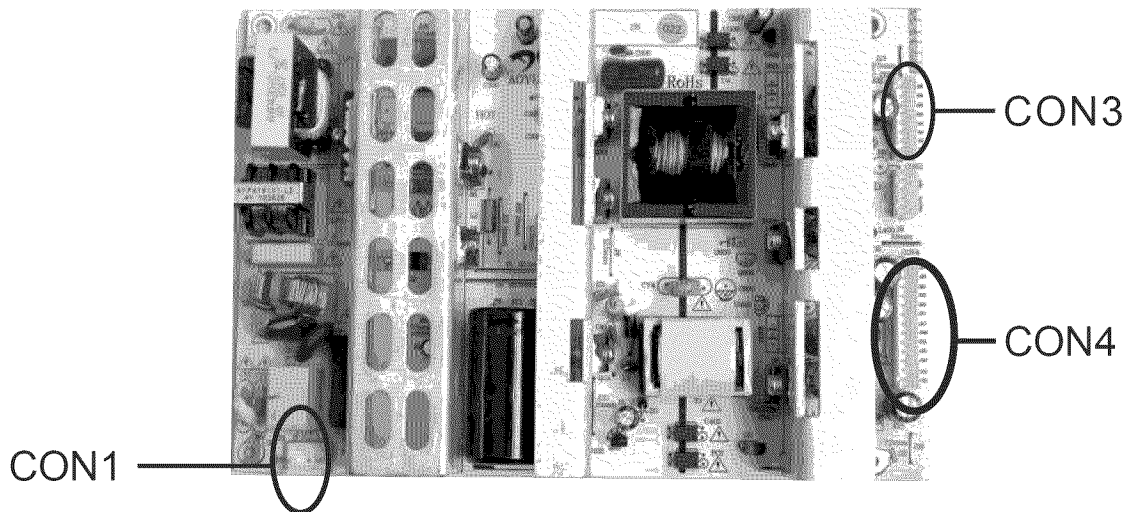

Jack List

Jack No.	Specification	Description	Connection	Note
CON1	2 Pin 3.96mm	AC input jack	To AC power supply	
CON3	8 Pin 2.54mm	Amplifier power supply Backlight power supply	To main board To LCD panel backlight inverters	
CON4	13 Pin 2.54mm	Main board power supply	To main board	

Chapter 3 Main Component

3.4 Connection Diagram

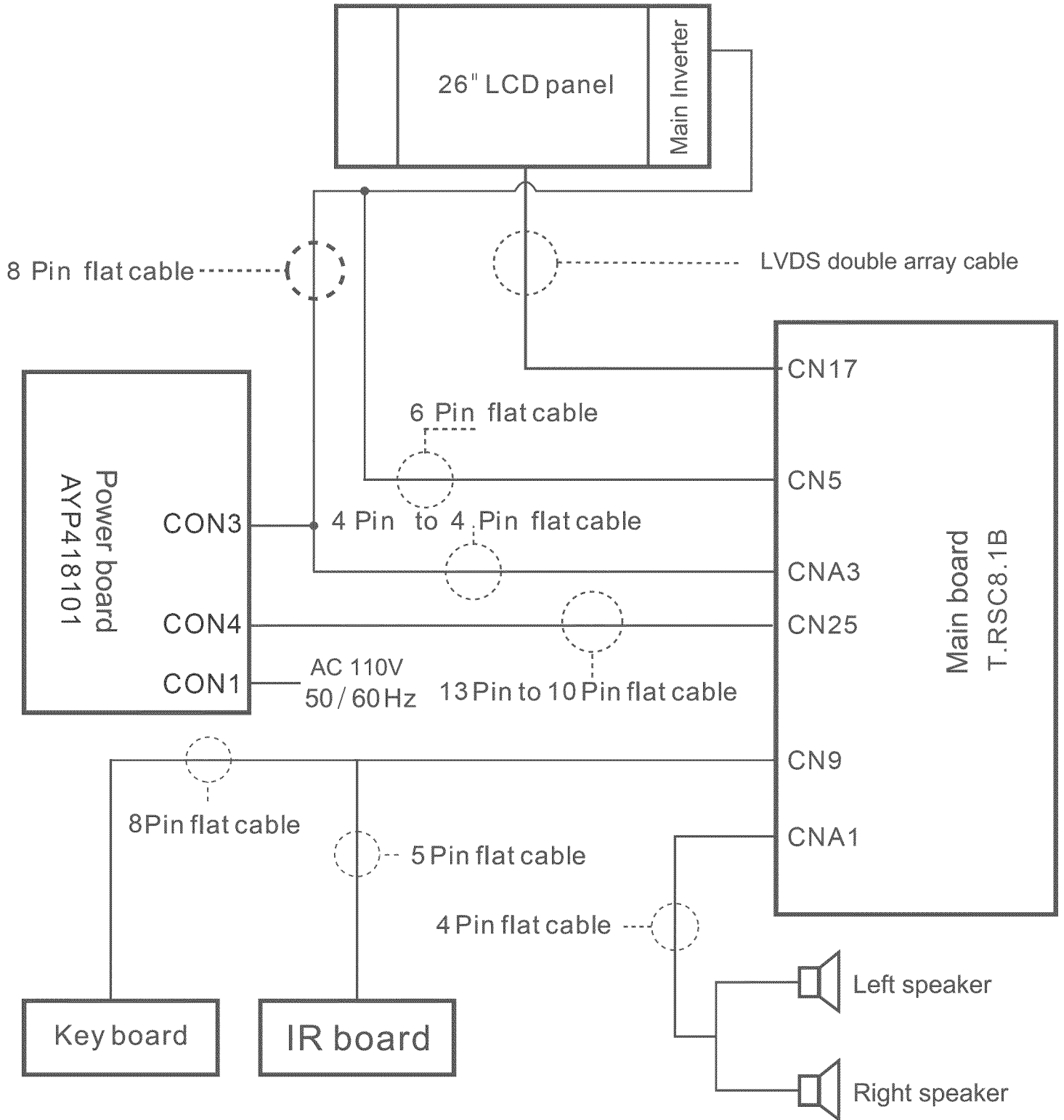

Chapter 4 Easy Troubleshooting

Note: Before opening the cabinet and working on the repairs, please read the troubleshooting and Q&A attached in the user's manual, which has covered most of the problems caused by improper using or settings to the TV set. If that does not work, please carry out the easy troubleshooting before checking or replacing the main parts of the television. The troubleshooting guides given below base on the situation in which the TV's functions are set and used properly.

Plus, if the easy troubleshooting can not help, please work on the repairing according to the procedures given in chapter 5, Exception Handles.

4.1 Troubleshooting for Common Use

TV can not be turned on

- Check the connection and condition of wires and inlets that relate to power board, including the AC power inlet, the power incoming wire, wires between power board and mainboard, etc.
- Check the diagram around power board to see if there exists a short circuit or creepage.
- The power board may be bad. Please change the board for testing. If it cannot help, refer to the chapter 5 for more intensive information.
- In addition, the malfunction of LCD panel can cause failure of power on. Please refer to 4.2 Troubleshooting for Displaying for more information.

Auto turning off

- Check the sleep timer setting.
- Check the surrounding diagram of power board. The problem is most possibly caused by short circuit or wire breakage, because this kind of malfunctions can cause excessive current, which will make the power board startup self-protection.

The screen goes black after a shorting blink

- If the TV screen can not display after the blink, that means the panel or other parts of equipment is broken (most likely by improper input voltage). Ensure the input voltage of every component, and then check the part that is suspected damaged.
- If this problem occurs repeatedly, check the surrounding diagram and connections of panel inverter board. Also, the backlight unit and LCD lamps should be checked out.

There exists afterimages after power off

- If the panel can work normally at the other time, it may be caused by bad mainboard. Upgrade to the latest software first, if that does not work, attempt to change the mainboard.

There exists squeak when TV is working

- Listen to the squeak carefully to make sure where the noise comes from. If it is from speakers, the voice may be caused by bad speakers. Change them for a try..
- If the noise comes from the inner parts of cabinet, it may be produced by abnormal AC current in power board. Change the board and check its surrounding circuits for a try.
- Check the routing of wires inside the cabinet to suppress interference.

Chapter 4 Easy Troubleshooting

4.2 Troubleshooting for Displaying

Note: If the troubleshooting given below can not help you, change the LCD panel for a try. But we strongly suggest you regard changing the panel as the last step of fixing the display problem.

No display (including white screen, black screen, etc.)

- Check the power board output and main board input ports to make sure whether the TV has been turned on successfully, because the failure in power on can lead to a no-display problem.
- If it is proved to have been electrified and turn on, check the LVDS cable first.
- Check if both of the two plugs of the flat cable between mainboard and power board have been well inserted into the slots. Unstable power supply can also cause serious display problem.
- If the display problem only happens in one input mode, that may be caused by wrong version software. Update the new software. If that can't help, change the main board for a try.

Screen tearing, or there exists moire on screen

- Bad LVDS cable and inappropriate panel driving voltage is still the biggest factor of this problem. So check them first.
- If the cable and voltage are correct, update the software for a try.
- Sometimes the fastening pieces can make unproper pressure to LCD panel, check them out.
- If the screen tearing happens in one or several input sources while the other source can display normally, it can be caused by bad mainboard most likely. Please change the mainboard for a try.
- Refer to chapter 5 for more details and resolution ways.

Straight dark/light line(s) on screen

- If the bad line is very narrow, it is usually caused by LCD panel malfunction, change the panel for a try.
- If the lines link together and become a bad band, upgrade the software and then check the ports and circuits of broken-down output mode(s).
- If the dark/light line, or band, appears in all the input modes, please change the LCD panel. But we suggest you check the panel inlet board(which links the panel and mainboard through LVDS cable) first, because sometimes the liquid crystal displaying unit is okay, while the inlet board has a transmitting problem, which also will lead to a displaying failure.
- Refer to chapter 5 for more details and resolution ways.

Color cast or interference

- If the cast or interference happens in only one input mode, check the output port(on mainboard) and transmitting network (around mainboard) of that mode.
- If the cast or interference happens in all the input modes, please exclude the malfunction according to easy troubleshooting for No Display. If that can not help, refer to chapter 5 for more details and resolution ways. In addition, most of this kind of problems come from the bad mainboards.

Chapter 4 Easy Troubleshooting

4.3 Troubleshooting for Audio

Note: Comparing with the display problem, the audio malfunctions are easier to work out. Constantly, if you have excluded the possibility of bad speakers and bad connection of audio output, the problem generally comes from the audio processing parts of mainboard. Please change mainboard for a try, or refer to chapter 5 for further information about repairing.

No Sound

- Check whether the speakers are broken first.
- Check the wire that links the mainboard and speakers. Watch if there is fracture or cladding material breakage.
- Check the joint of speakers and audio wire, watch if there is poor soldering or fake solder. Besides, the polarity mistake can also lead to audio problem.

Volume too low

- Check whether there is a jam at the sound hole in front cabinet.
- Check whether one or more speakers are bad.

Sound channel loss or confounding

- Check whether the audio wires are installed reversedly. The left channel wire should be white and the right channel wire is red.
- Check the audio output socket of mainboard to see whether it is wrongly inserted. If not, the mainboard audio output module may be bad, refer to chapter 5 for more details and resolution ways.
- If the connection is stable and right, the mainboard audio output module may be bad, refer to chapter 5 for more details and resolution ways.

Noise

- Check if there is anything should not exist in the speaker hollow space (such as screws).
- Check if the antihunting EVA is broken or missing.
- Check if the speakers are bad.

4.4 Troubleshooting for Keyboard

No key can work

- Check the wire between mainboard and keyboard, watch if there is fracture or cladding material breakage.
- Check the joint of mainboard and keyboard wire, watch if there is poor soldering or fake solder.
- Check the resistances that locate on the keyboard PCB. Watch if there is wrong or broken ones. Also, the poor soldering of fake solder should be concerned and checked carefully.
- Check the other components of keyboard (such as capacitances and microswitches) are wrong or bad.

Chapter 4 Easy Troubleshooting

Keys are sunken

- Check the screws that fasten the keyboard to the cabinet. They may be lost or getting loose.
- The key set may be bad, change them.

There is a reacting delay when operating the keys

- That is usually caused by bad keyboard, change it for a try.

Functions of keys are out of order

- Check the keyboard to see whether there is a short circuit between each soldering joint.
- Check all the resistances on PCB board.
- If a key is supposed to be able to achieve more than one functions, but it can achieve not all of them, that is usually caused by wrong software. Please update the latest and correct software for a try.
- If you can't ensure where the problem comes from, change the keyboard for a try. If that still can't help, refer to chapter 5 for more details and resolution ways.

4.5 Troubleshooting for Remote Control

Note: If the troubleshooting can not help, please change the RC board. If that still can't solve the problem, please refer to chapter 5 for more details and resolution ways with a will to mainboard repairing.

The RC (remote control, the same below) does not work

- Check the wire between mainboard and RC board, watch if there is fracture or cladding material breakage.
- Check the joint of mainboard and RC board wire, watch if there is poor soldering or fake solder. Also, the short circuit can lead to this problem, too.
- Check the infrared sensor that locates on the keyboard PCB. Watch if it is wrong or broken. Also, the poor soldering of fake solder should be concerned and checked carefully.
- Check the other components of RC board are wrong or bad.

The LCD displays light in wrong color

- The short circuit is the most probable causation factor of this proble. Check the wire and joints for a judgement.
- Check the cable that links mainboard and RC board, watch if it is inserted with wrong location(similar with left-right channel wire fault for audio).
- Check the LCD assembling, watch if its pins are in wrong location.

Chapter 5 Exception Handles

Note: The exception handles are prepared for qualified personal only.

5.1 Display Exceptions

5.1.1 Black screen and no display

Note: If the troubleshooting guide can not help you with the obviation of faults, please change the non-conforming materials to rework.

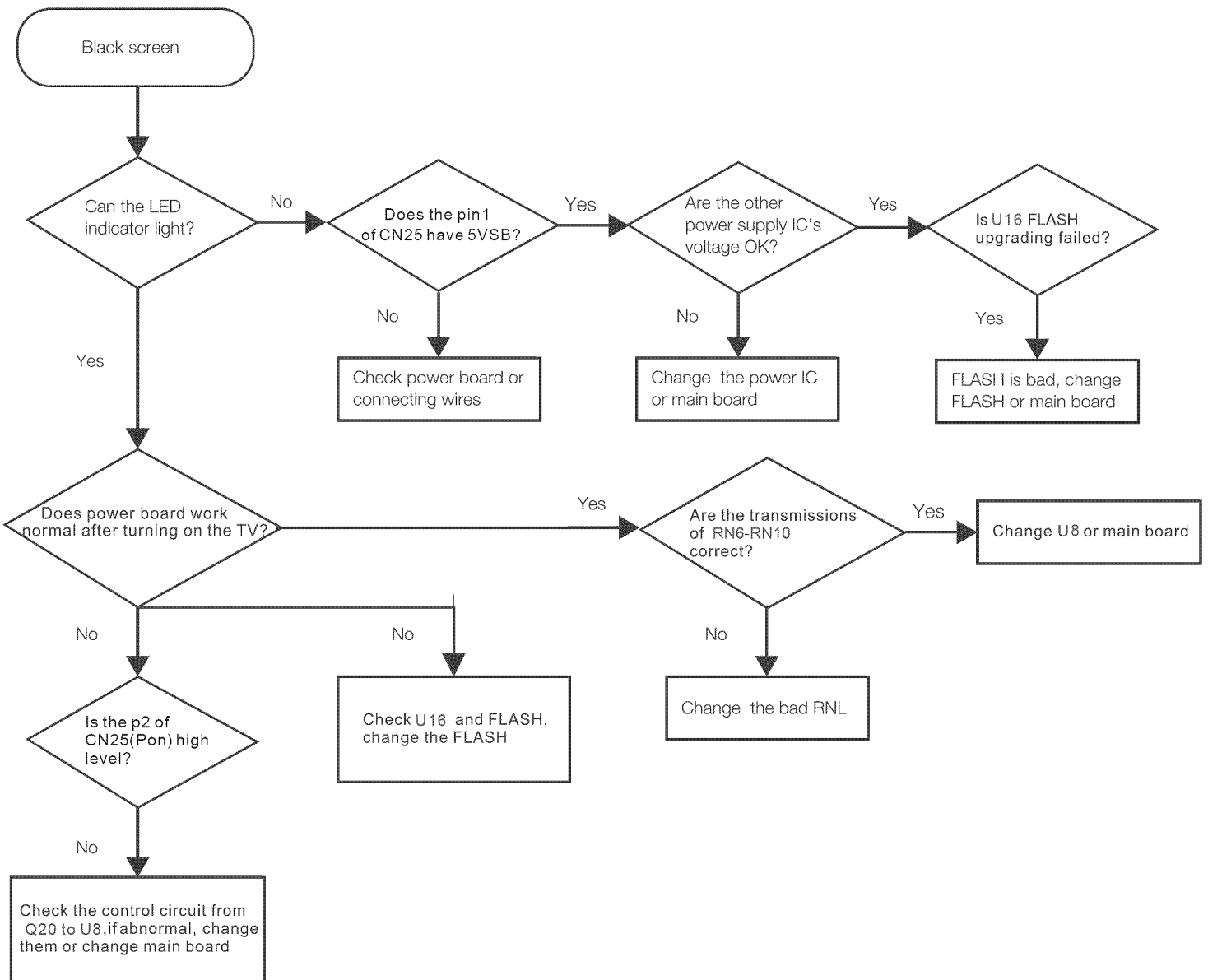

Chapter 5 Exception Handles

5.1 Display Exceptions

5.1.2 White screen

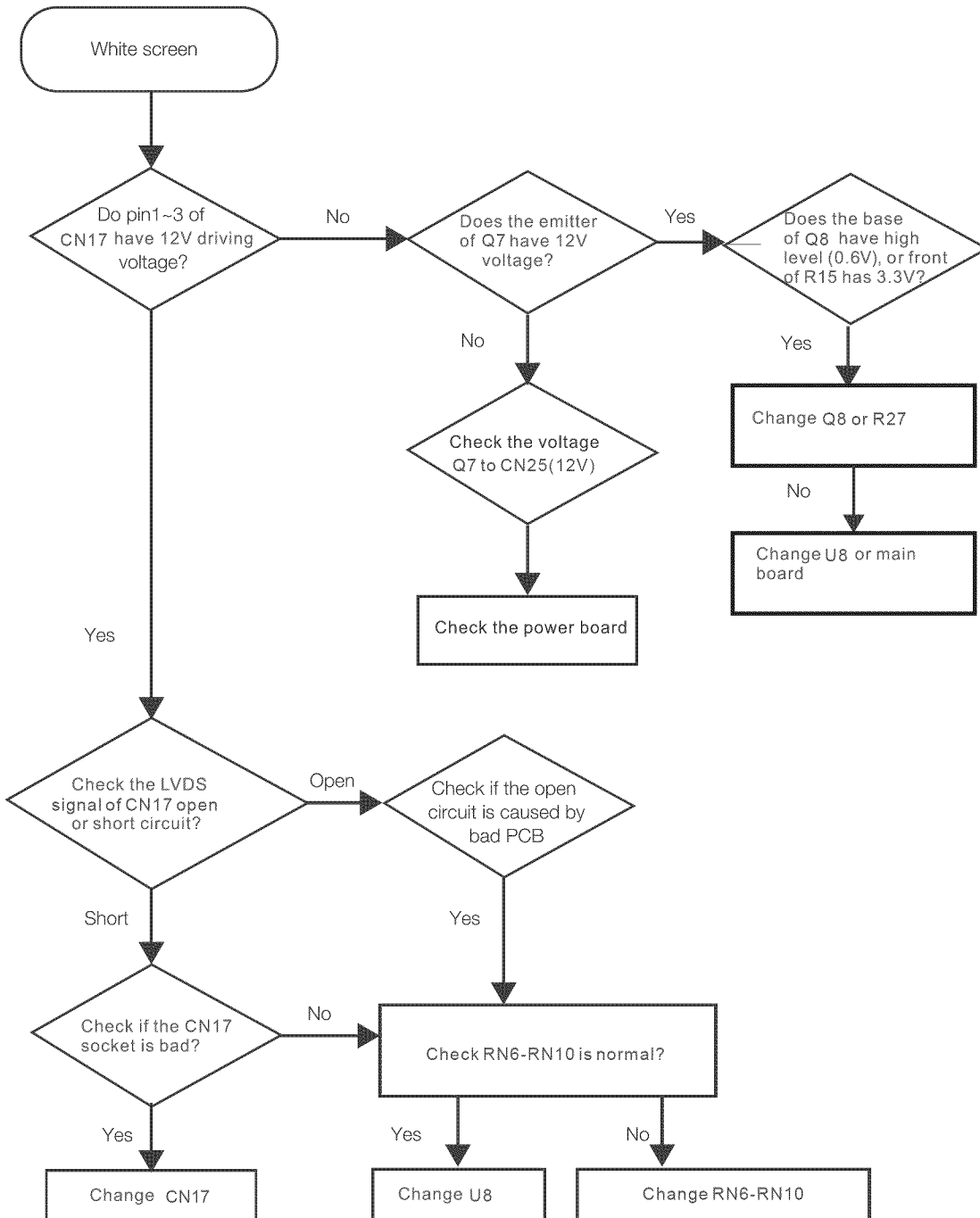

Chapter 5 Exception Handles

5.1 Display Exceptions

5.1.3 Dazzling screen

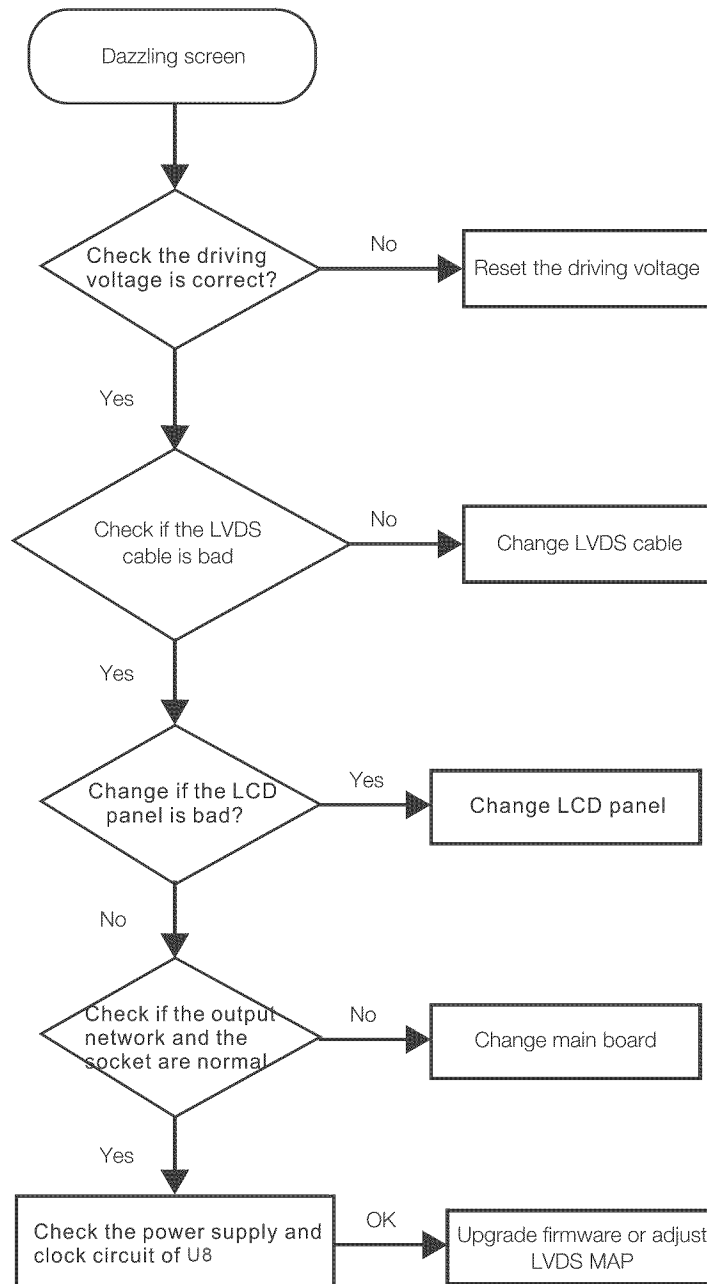

Chapter 5 Exception Handles

5.2 Audio Exceptions

5.2.1 No sound (completely)

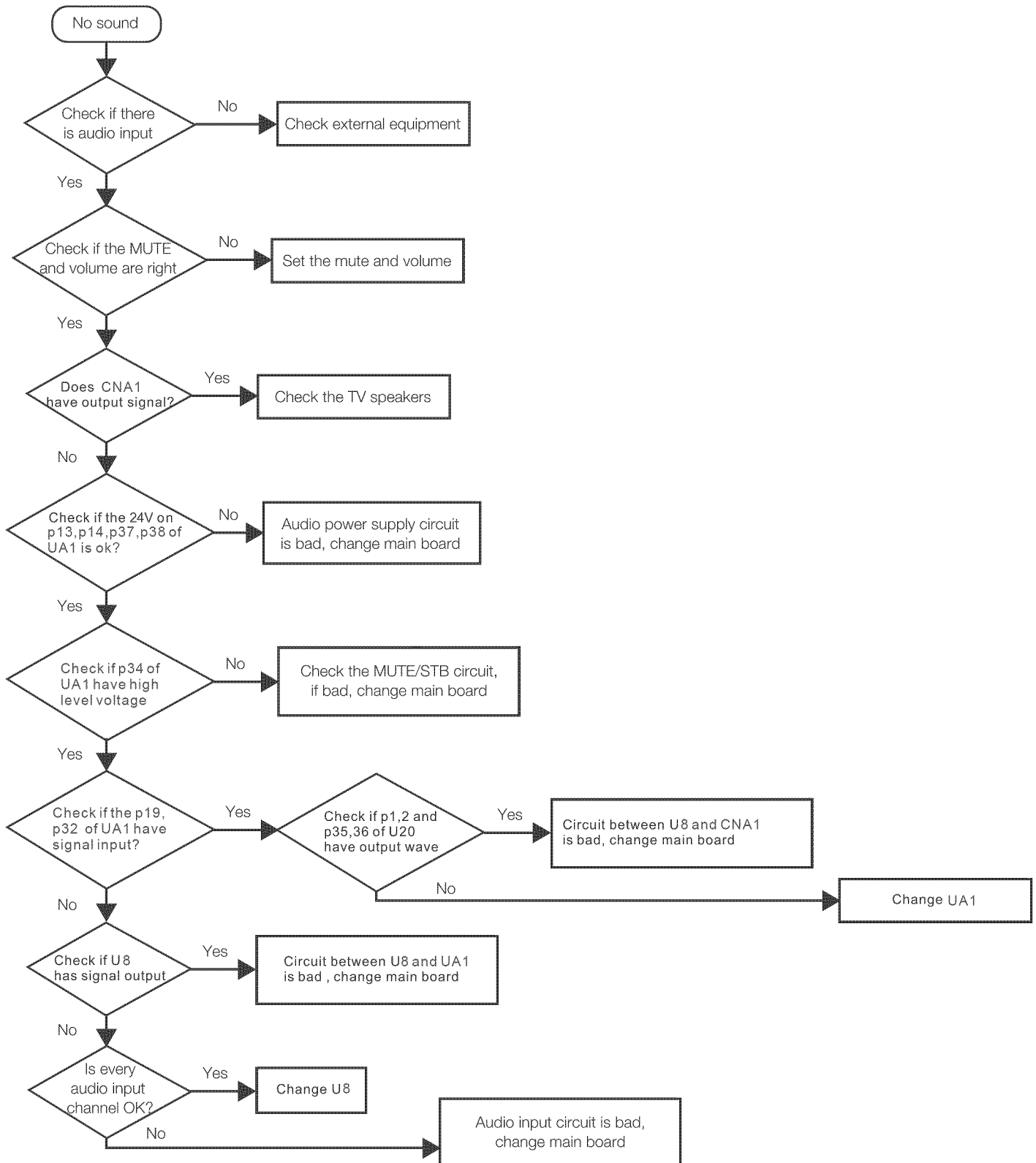

Chapter 5 Exception Handles

5.2 Audio Exceptions

5.2.2 No sound (TV)

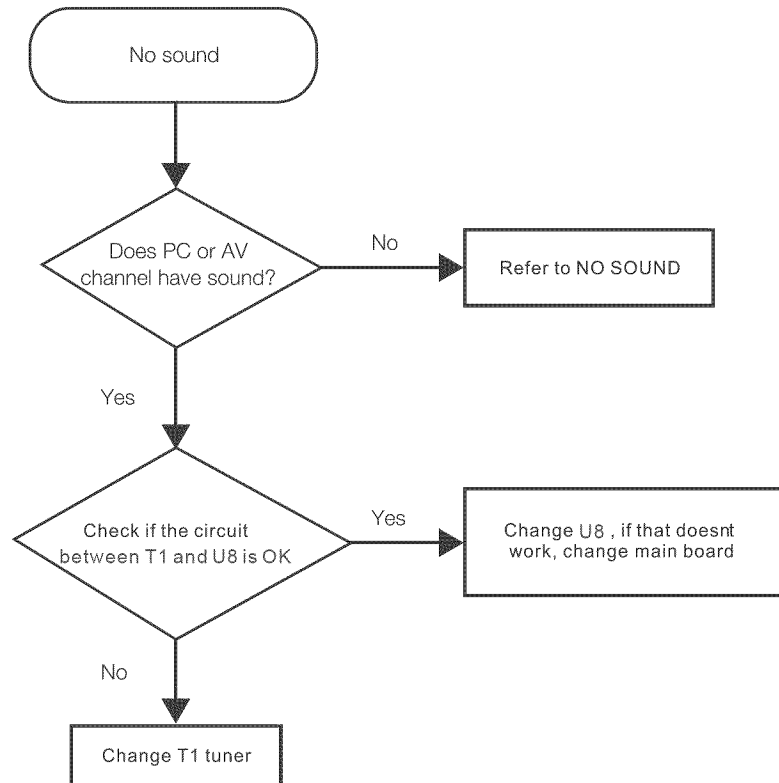

Chapter 5 Exception Handles

5.2 Audio Exceptions

5.2.3 No sound (HDMI)

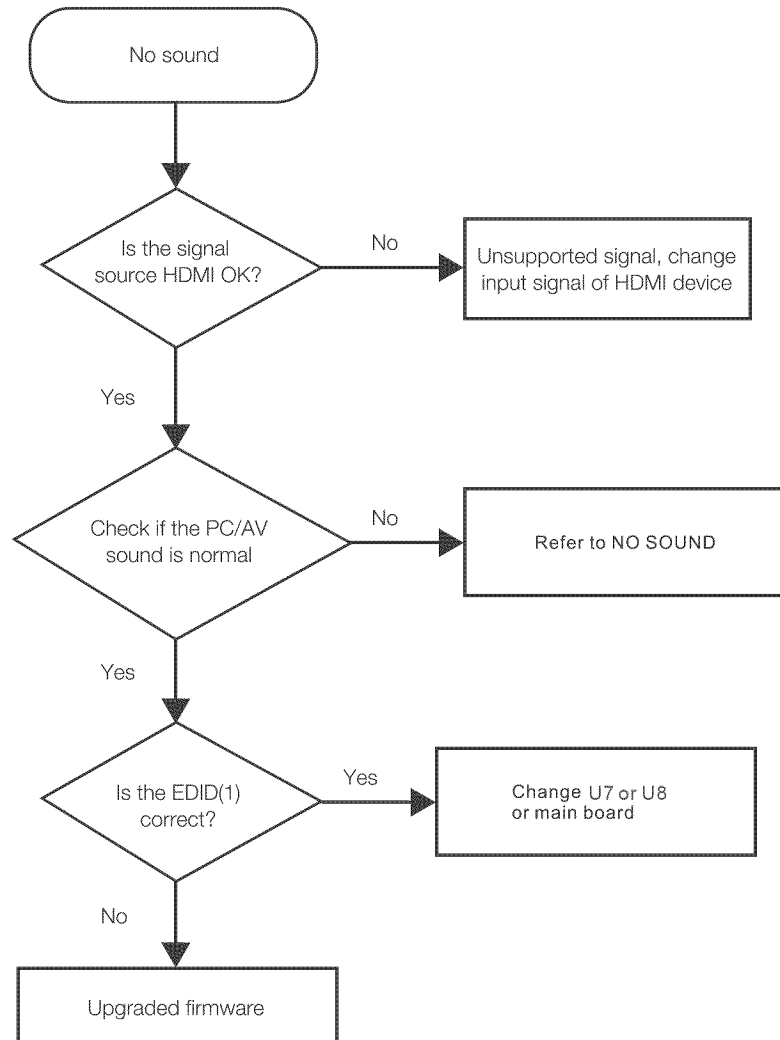

Note (1): EDID means Extended Display Identification Data

Chapter 5 Exception Handles

5.3 Function Exceptions

5.3.1 TV function

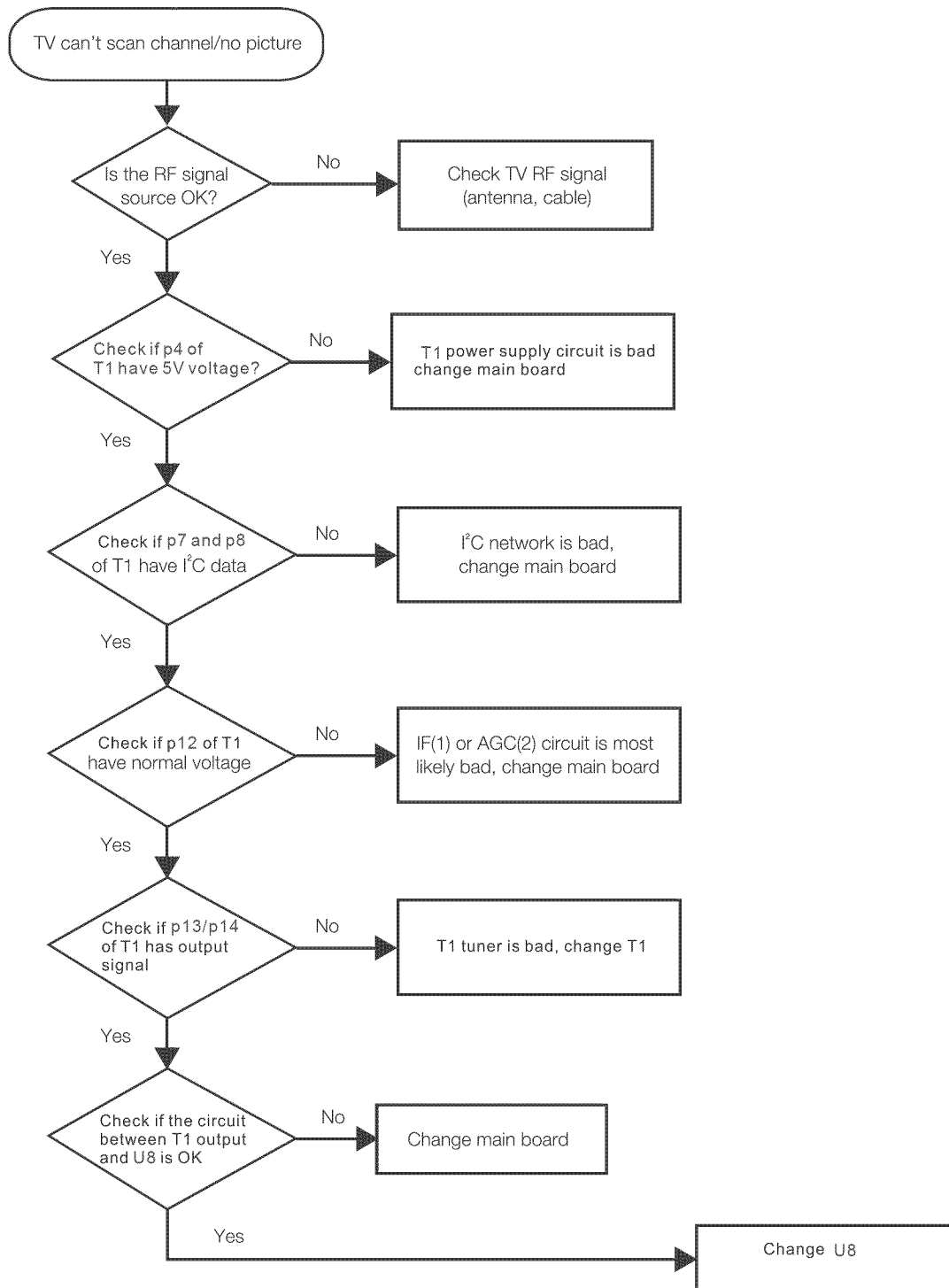

Note: (1) IF: Intermediate Frequency
(2) AGC: Automatic Gain Control

Chapter 5 Exception Handles

5.3 Function Exceptions

5.3.2 HDMI no picture

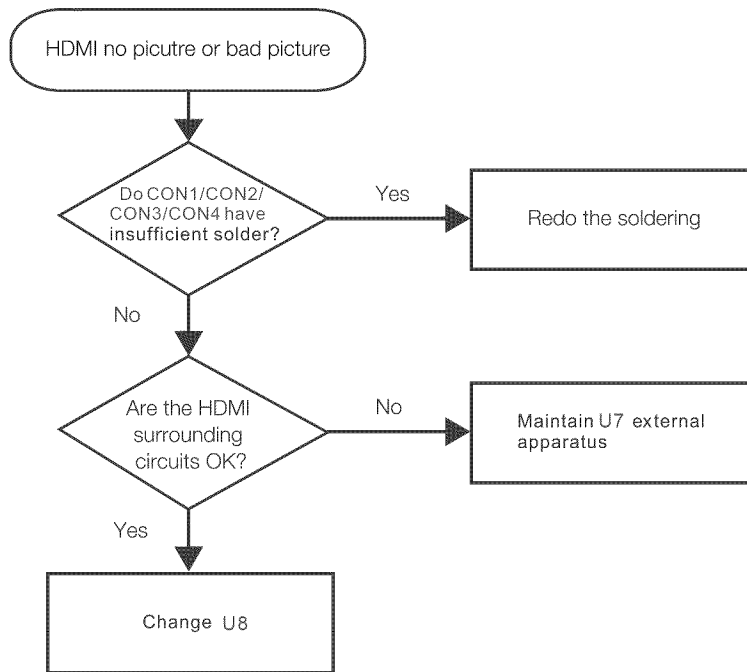

Chapter 5 Exception Handles

5.3 Function Exceptions

5.3.3 YPbPr no signal

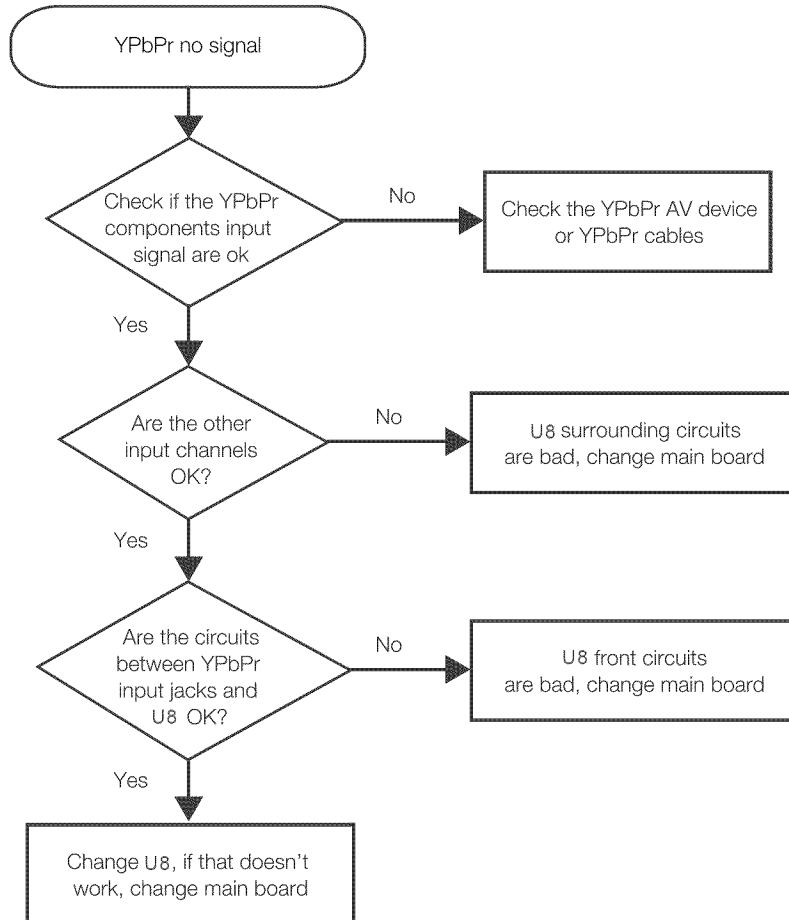

Chapter 6 Firmware Upgrading

REC7 series main board has a USB SERVICE port, which is reserved for service use only. Please upgrade the firmware according to the instruction below.

6.1 Direct upgrading (do no need normal display)

STEP 1

Get an empty USB disk with size not larger than 2GB, copy firmware file (**CompBase.bin**, or **AllCompBase.bin**) to the root directory of disk.

Note: the size of USB disk can not be larger than 2GB, and before copying the firmware file, make sure the disk is empty. And the file must be placed in the root directry.

STEP 2

Turn off the TV, insert the USB disk into the SERVICE jack on the side panel of TV and then turn on the TV. After turned on, the TV's LED indicator will shine red and blue alternately. Wait for about one and half a minute to accomplish the upgrading.

Note: DO NOT power off or unplug the TV while upgrading.

6.2 Factory upgrading (need normal display)

STEP 1

Get an empty USB disk with size not larger than 2GB, copy firmware file (**AllCompBase.bin only**) to the root directory of disk.

Note: the size of USB disk can not be larger than 2GB, and before copying the firmware file, make sure the disk is empty. And the file must be placed in the root directry.

STEP 2

Turn on the TV, insert the USB disk into the SERVICE jack on the side panel of TV. Then press the remote control buttons "MENU" → "1147" to enter factory menu (see below).



STEP 3

Choose "USB UPDATE" and press OK. If there are "CompBase.bin" and "AllCompBase.bin" in the disk at the same time, be sure to select "AllCompBase.bin" to update. The upgrading phenomenon is the same to direct upgrading.

Note: DO NOT power off or unplug the TV while upgrading, otherwise the upgrading will fail, and the main board will be unable to upgrade normally any more.

Main Board (PCB)

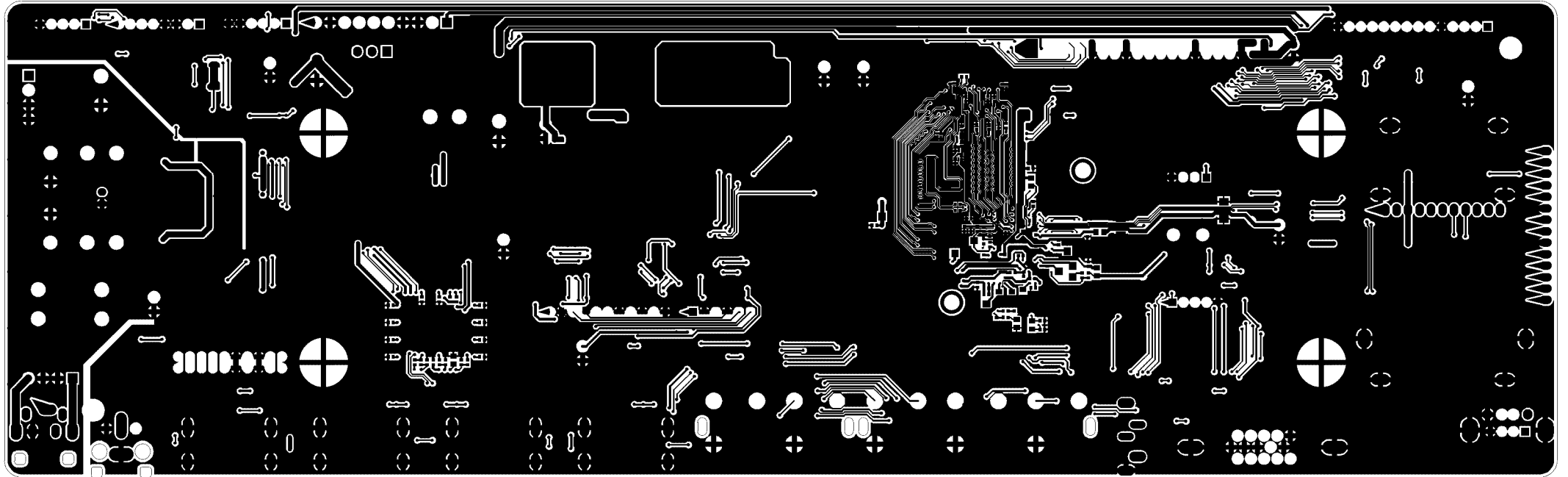

Main Board (PCB)

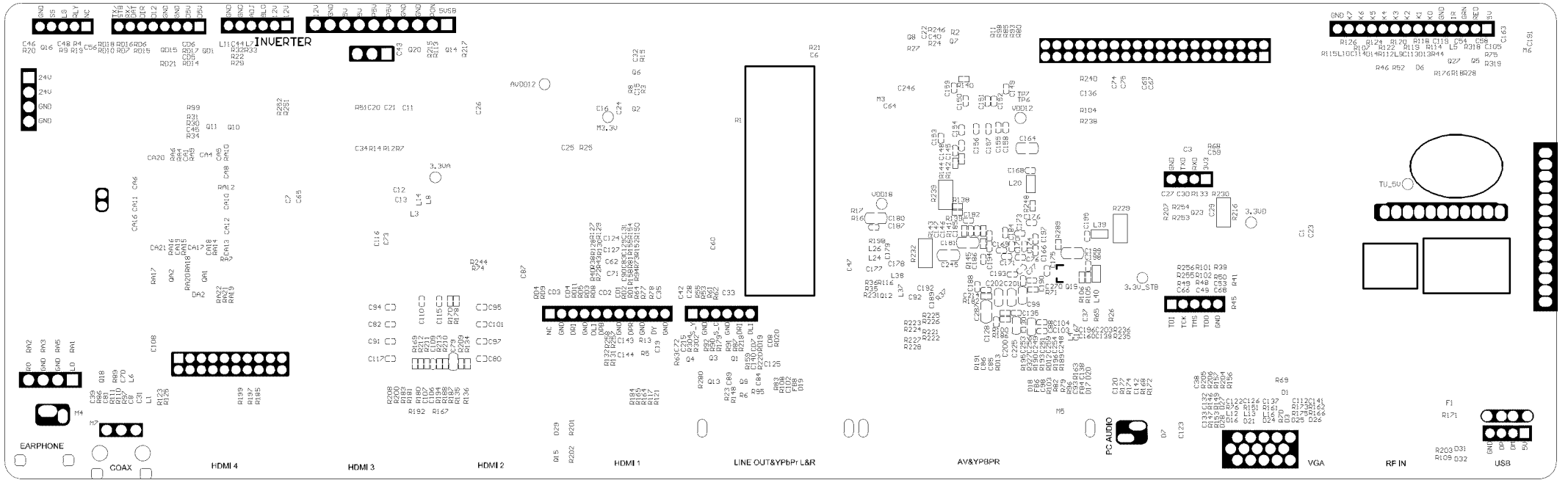

Main Board (PCB)

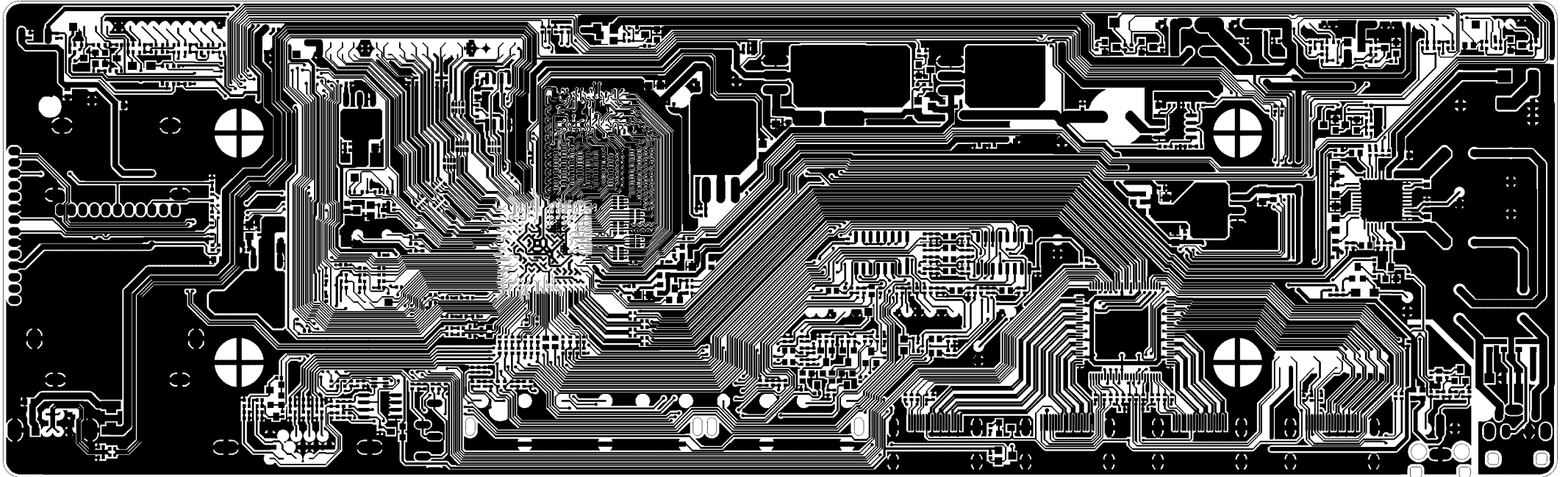

Main Board (PCB)

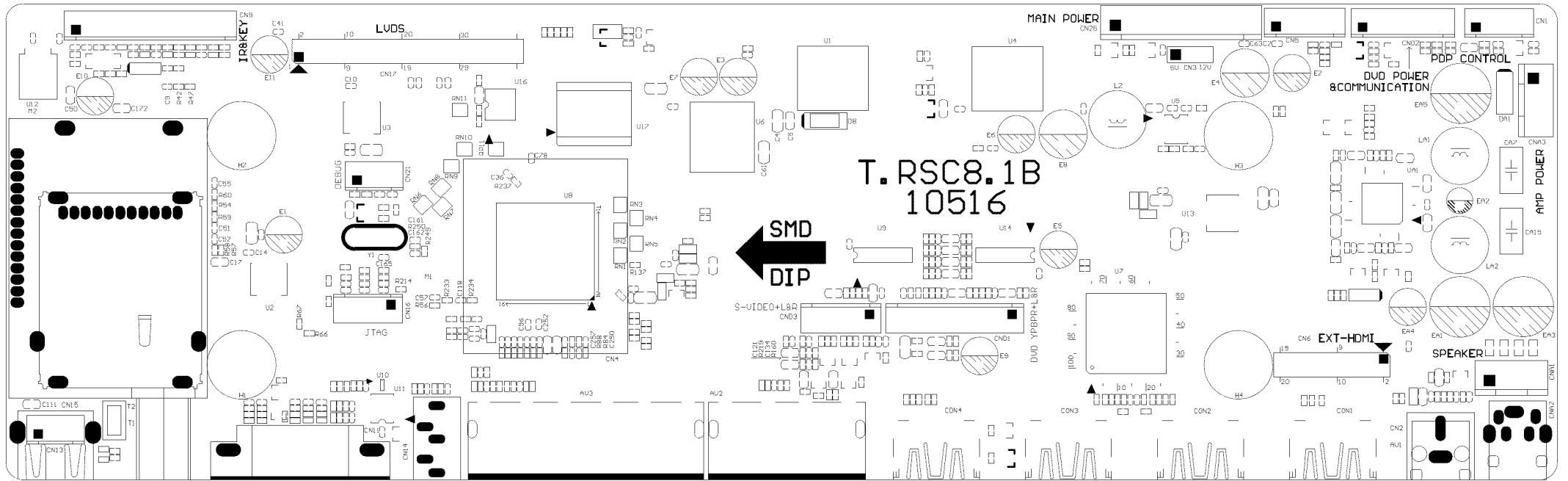

Main Board (SCH)

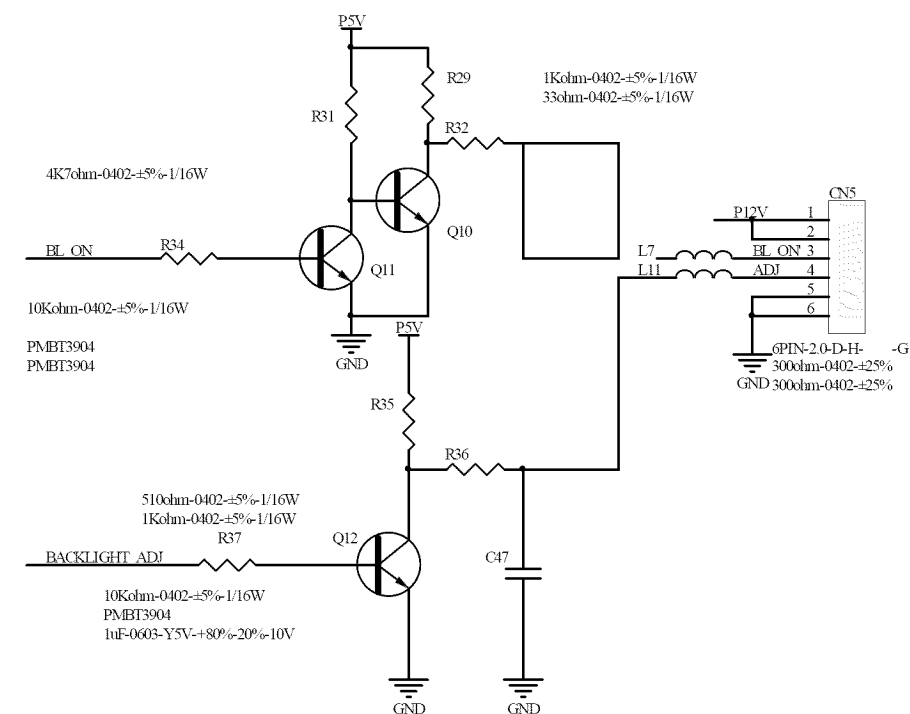
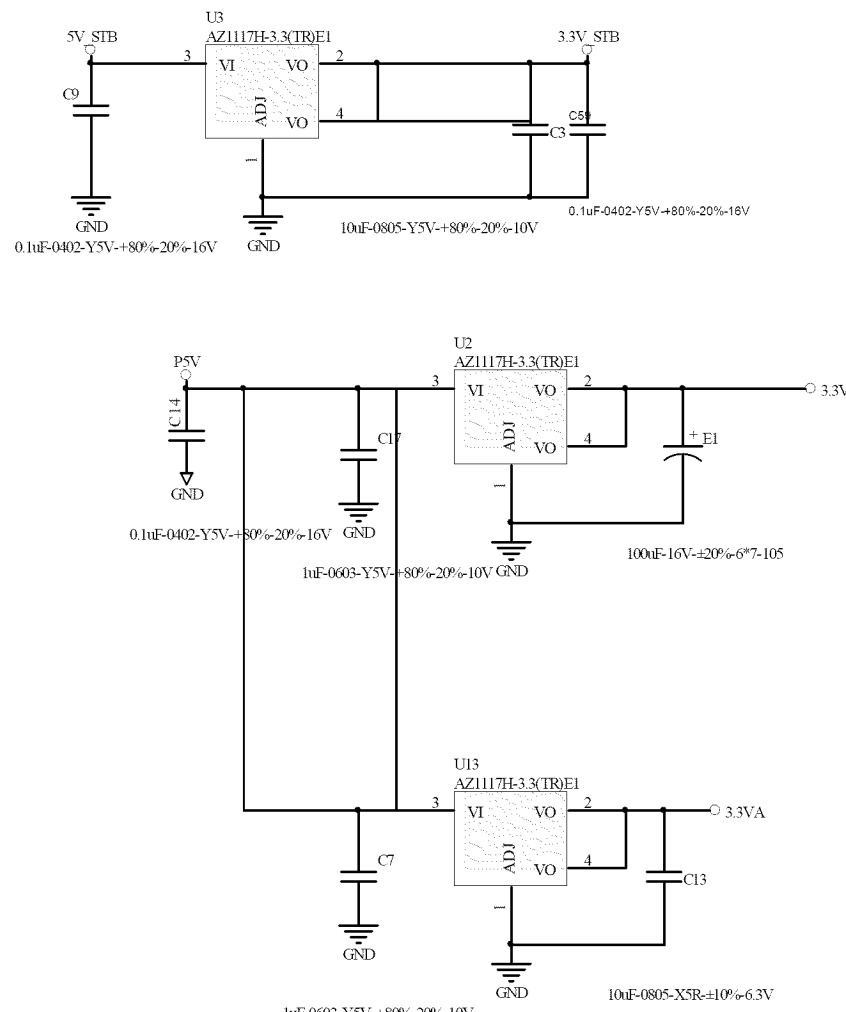
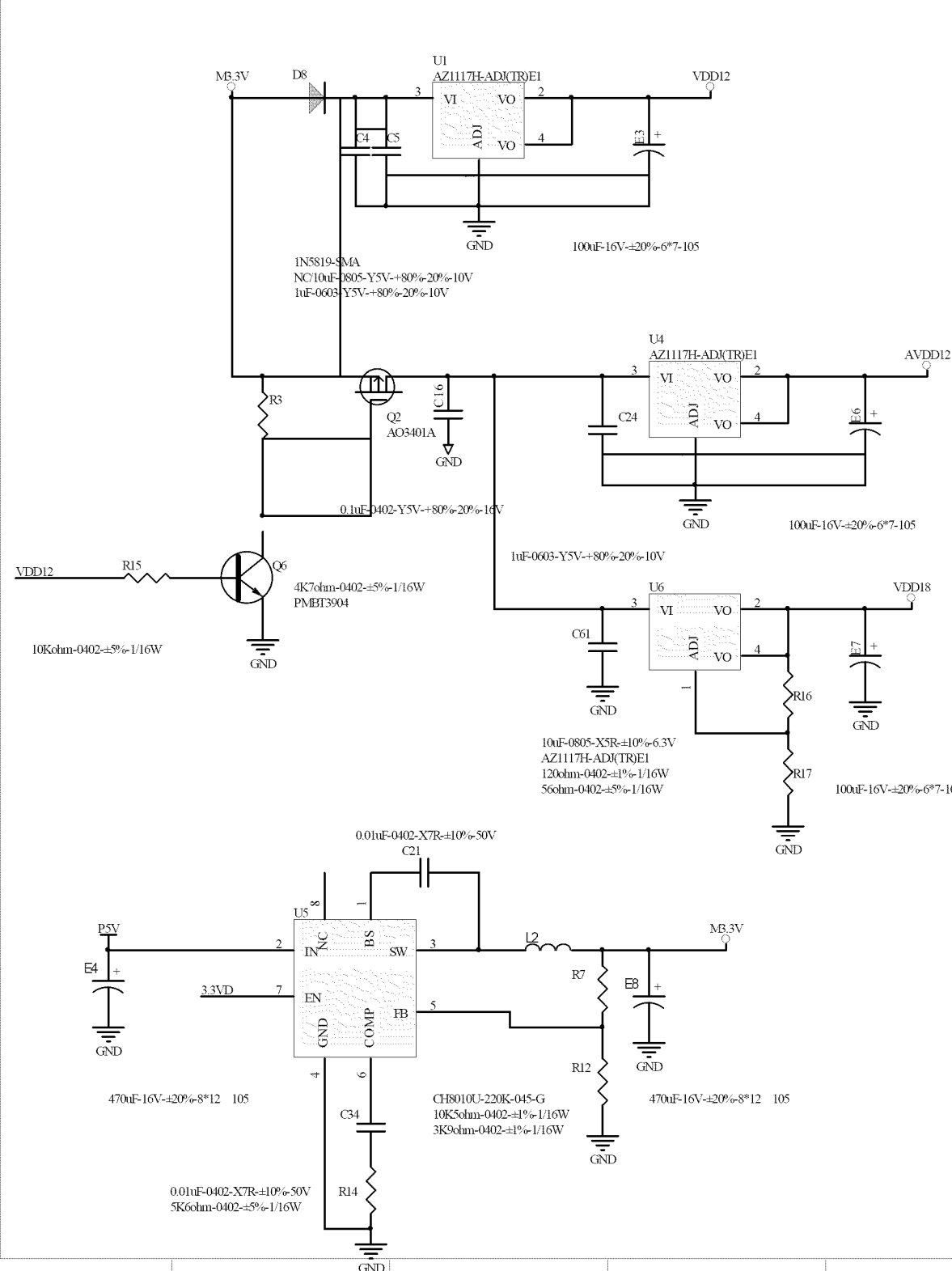
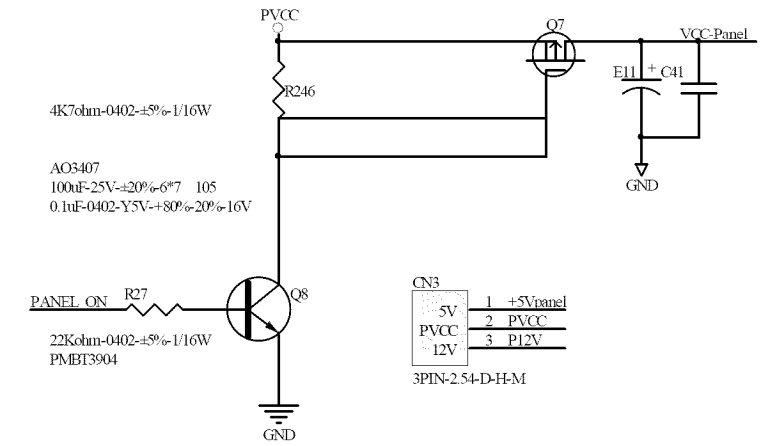
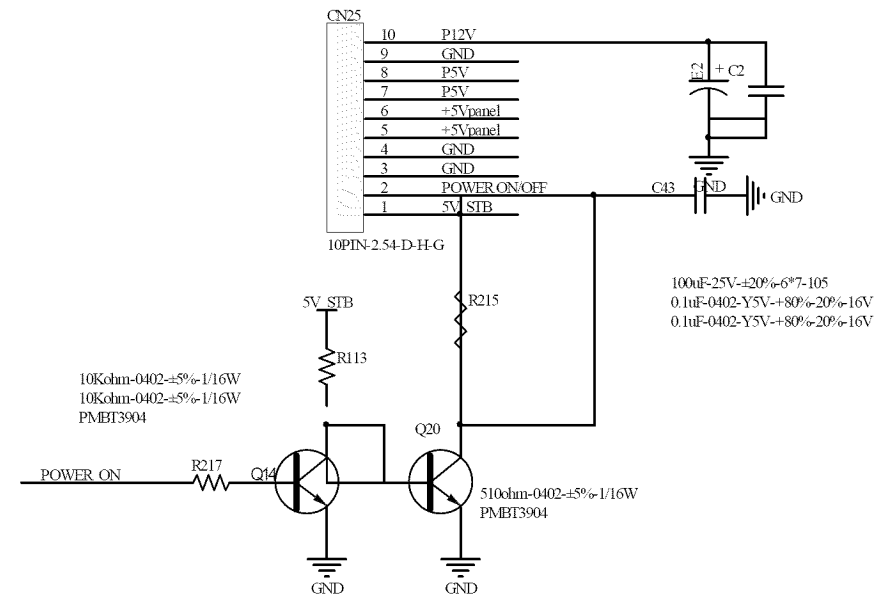

Main Board (SCH)

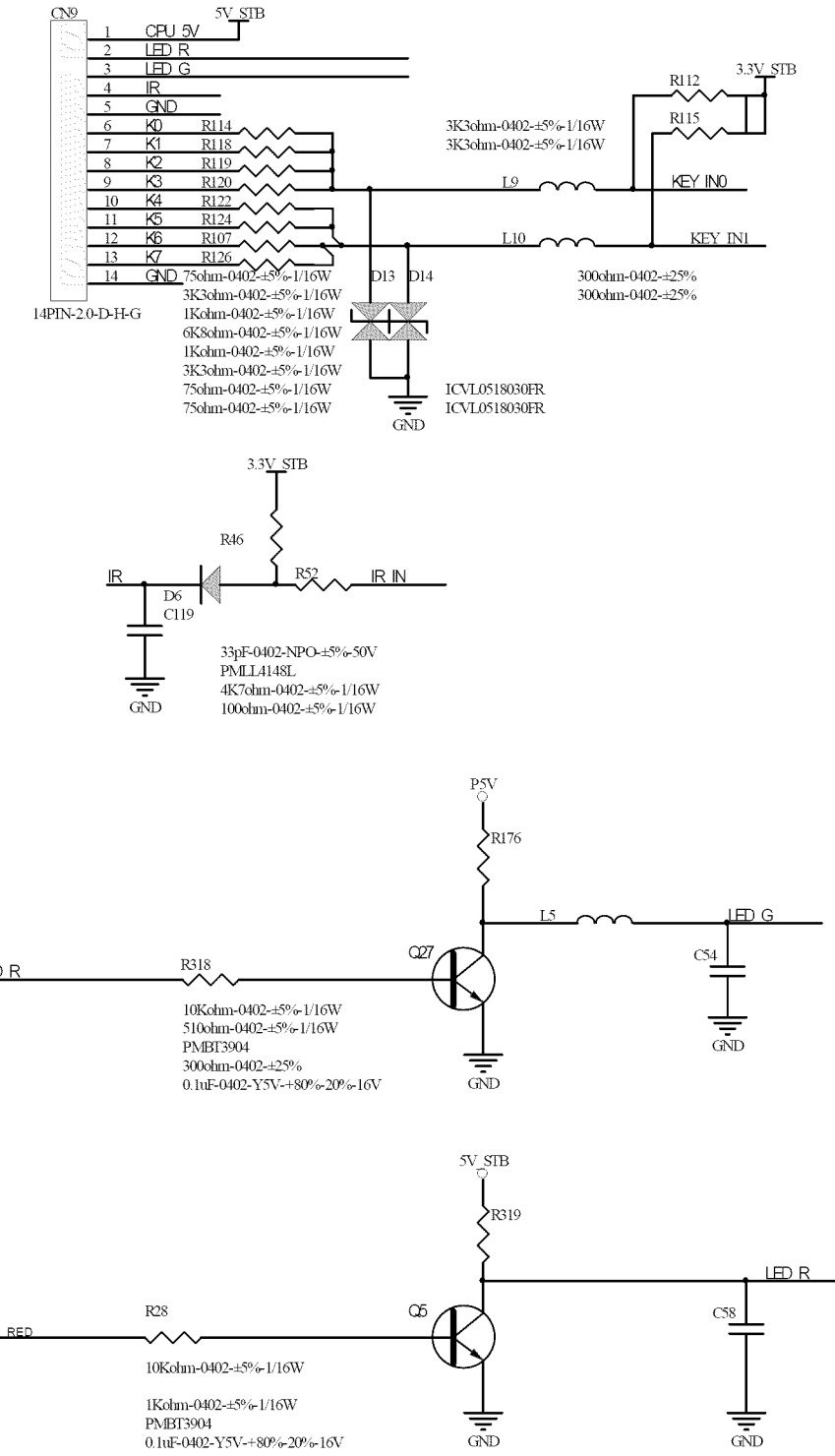
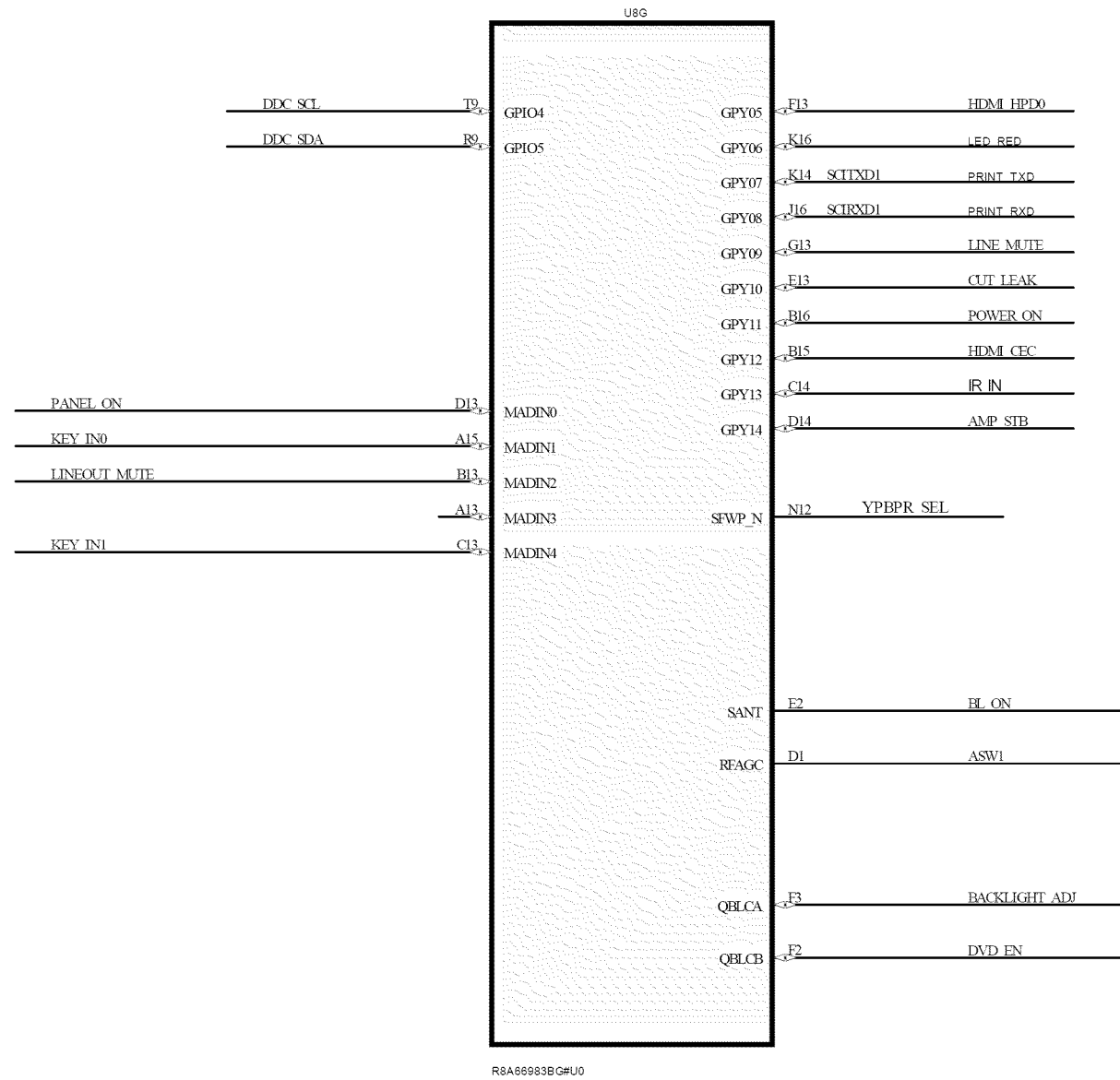

Main Board (SCH)

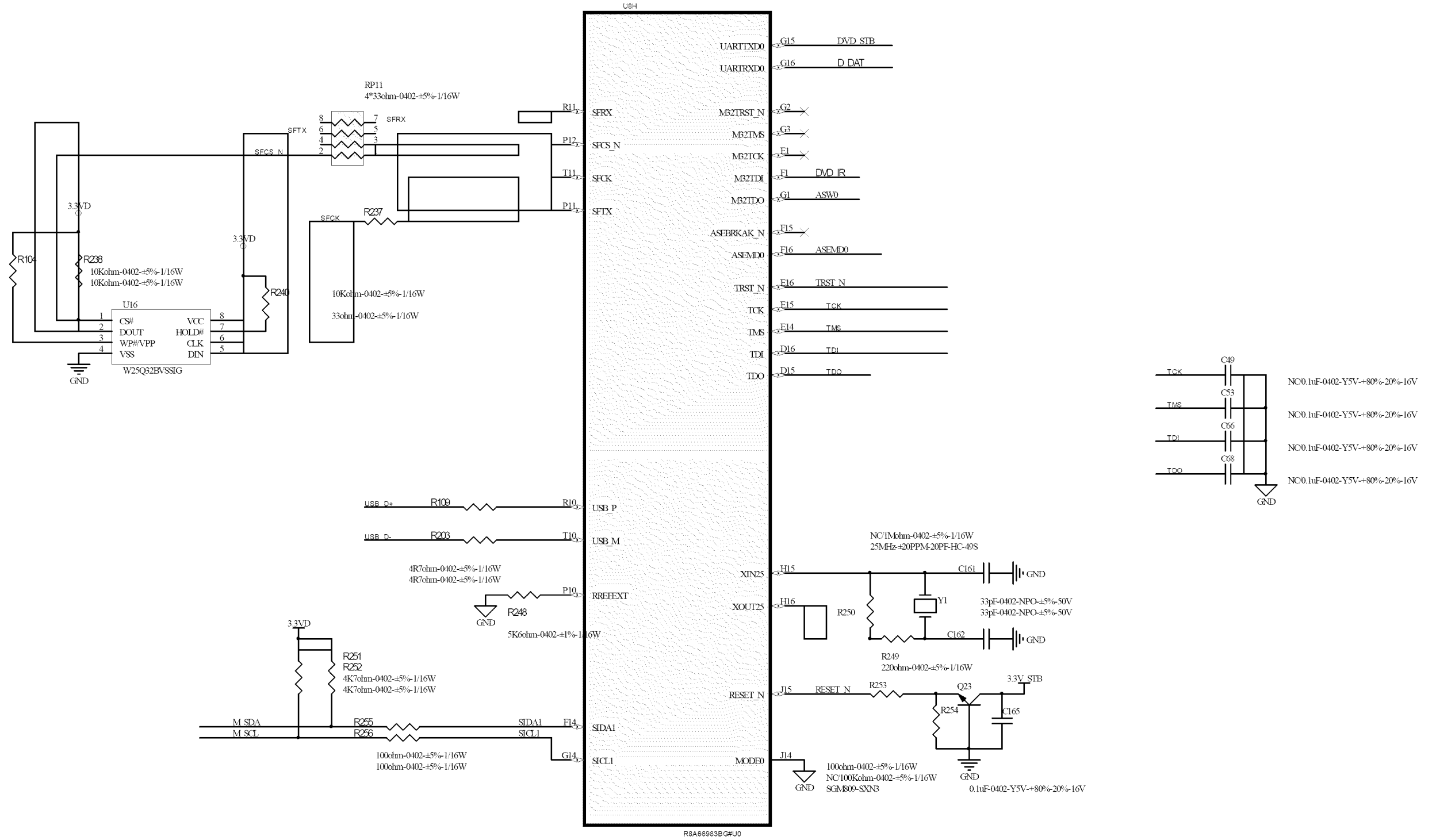

Main Board (SCH)

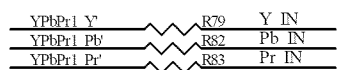
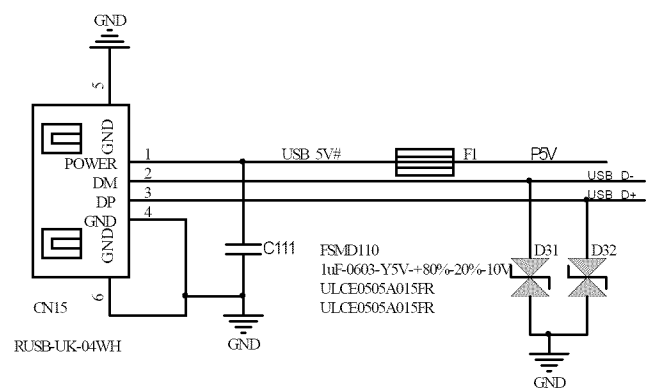

NC00hm-0402-±5%-1/16W
NC00hm-0402-±5%-1/16W
NC00hm-0402-±5%-1/16W

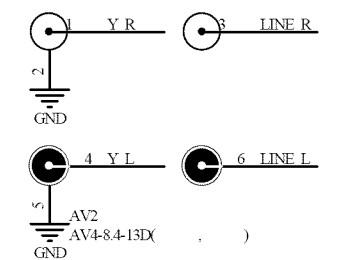
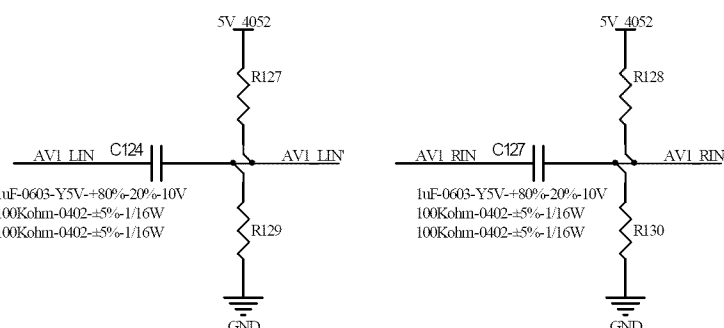
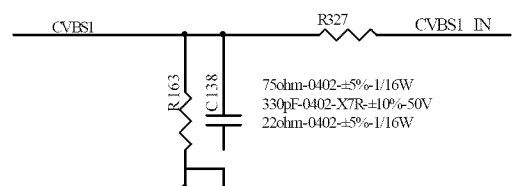
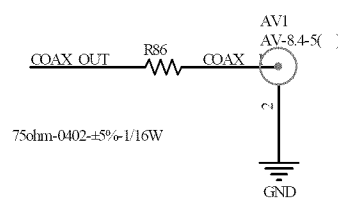
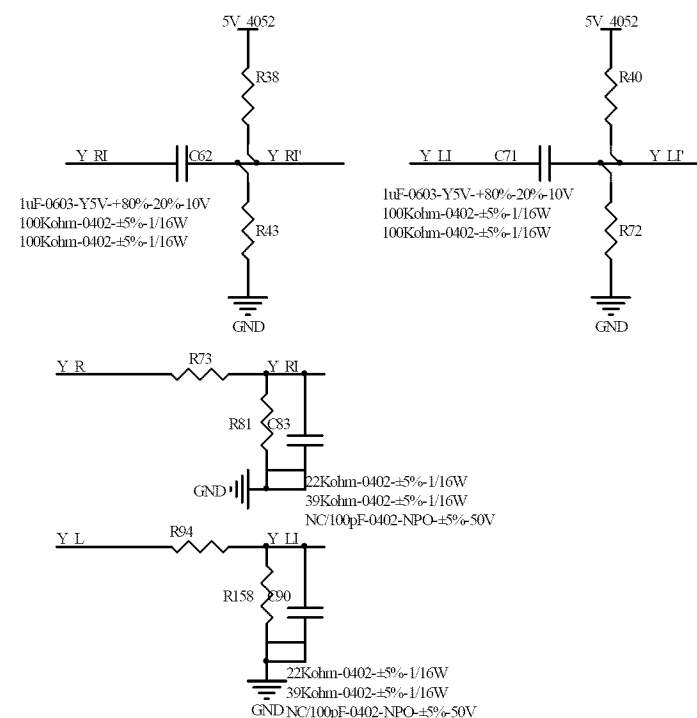

Main Board (SCH)

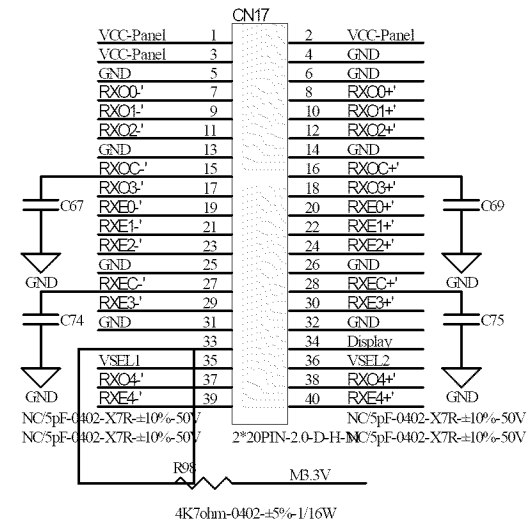
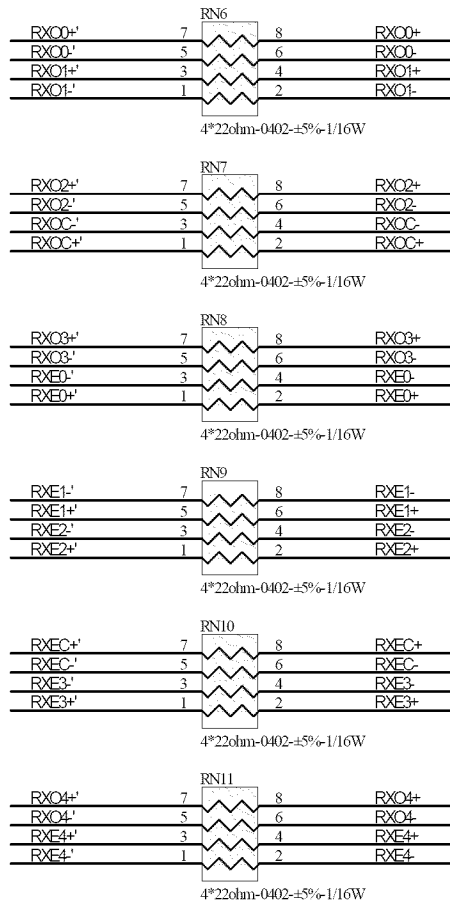
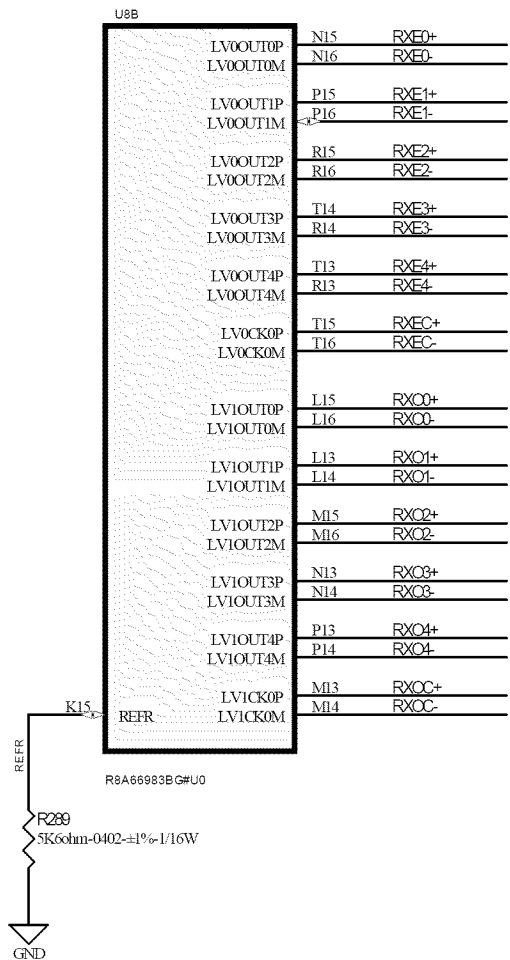
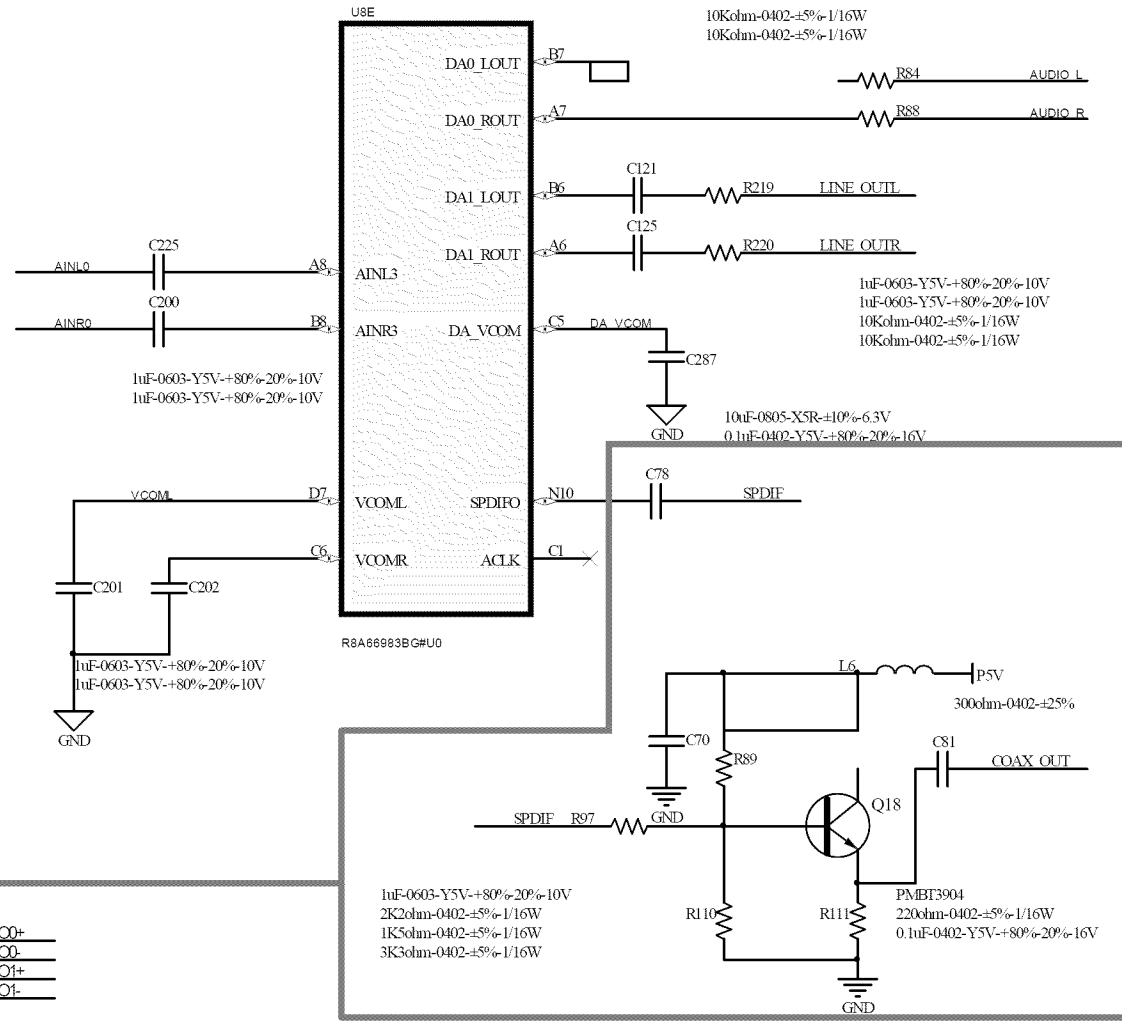
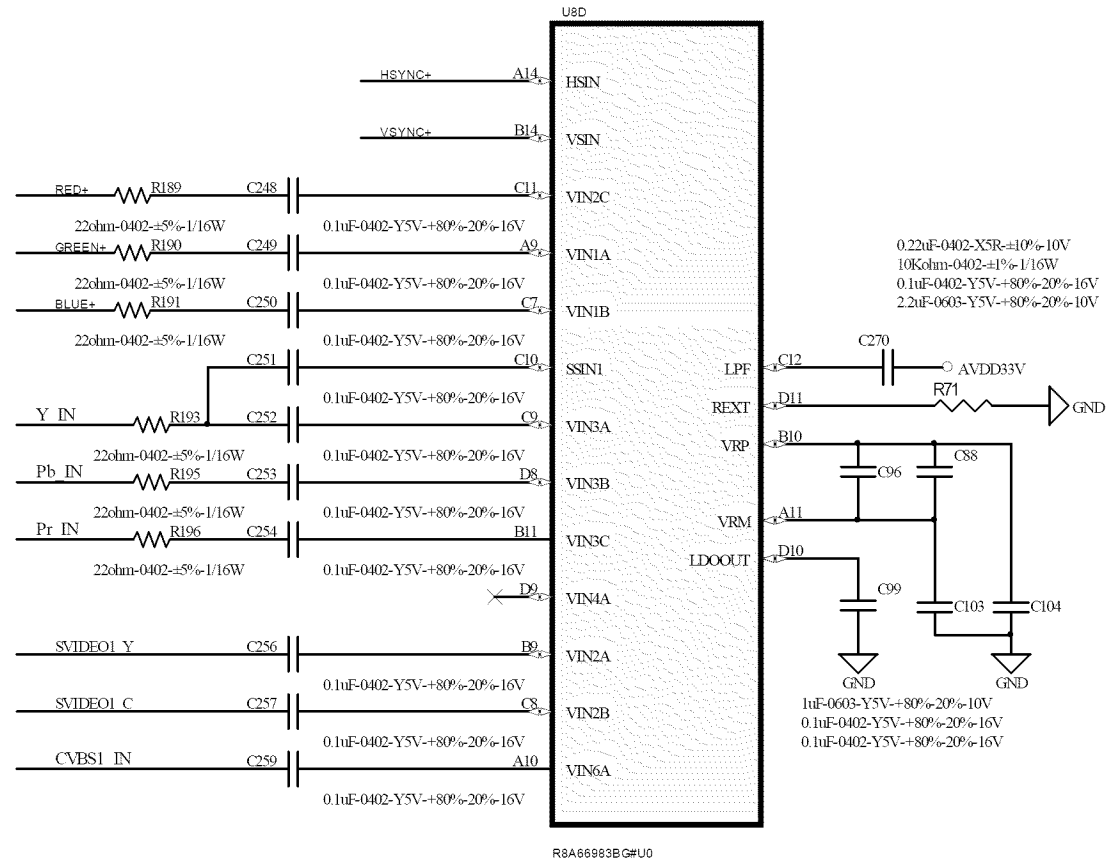

Main Board (SCH)

Power-Block

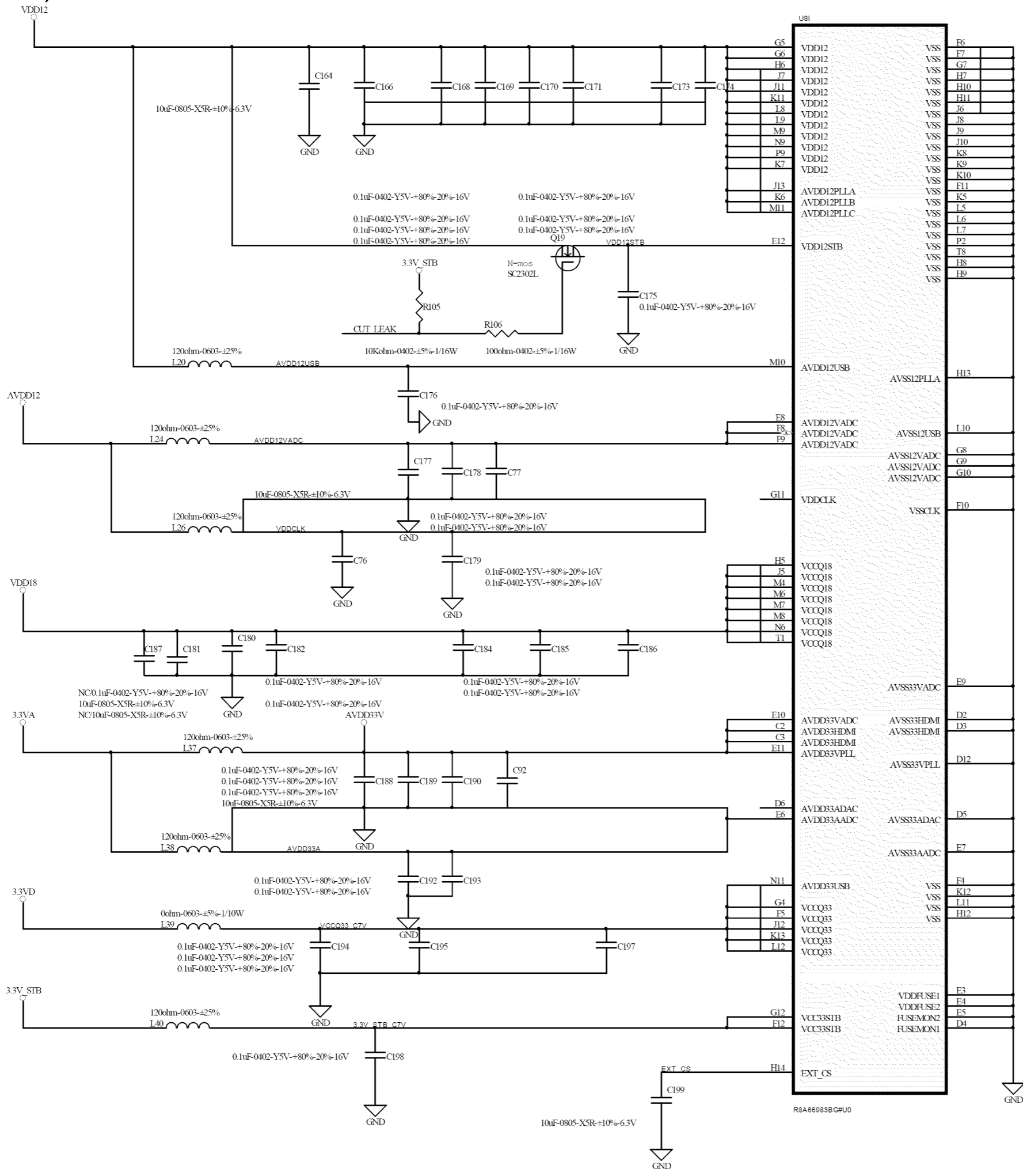

Main Board (SCH)

DDR2-SDRAM(DDR2-800) (2-layers custom)
1Gbit(64Mwords x 16bits)

84pad

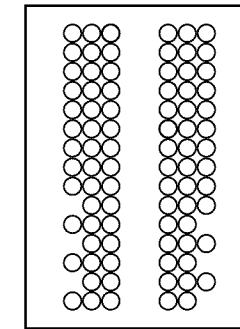

TOP VIEW
max pkg. 11x13mm

DDR2 i/f-Block

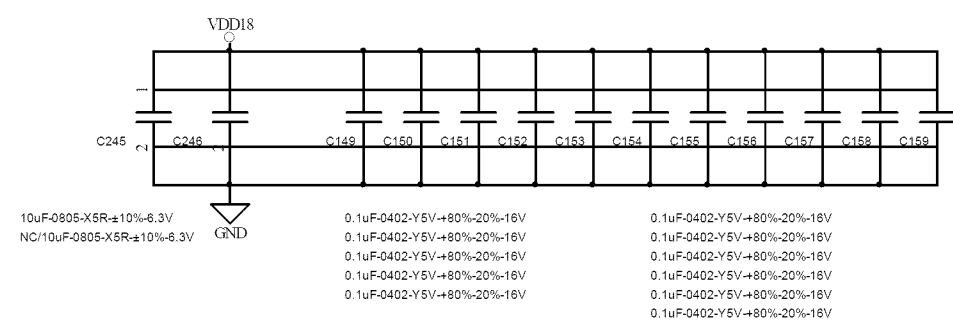
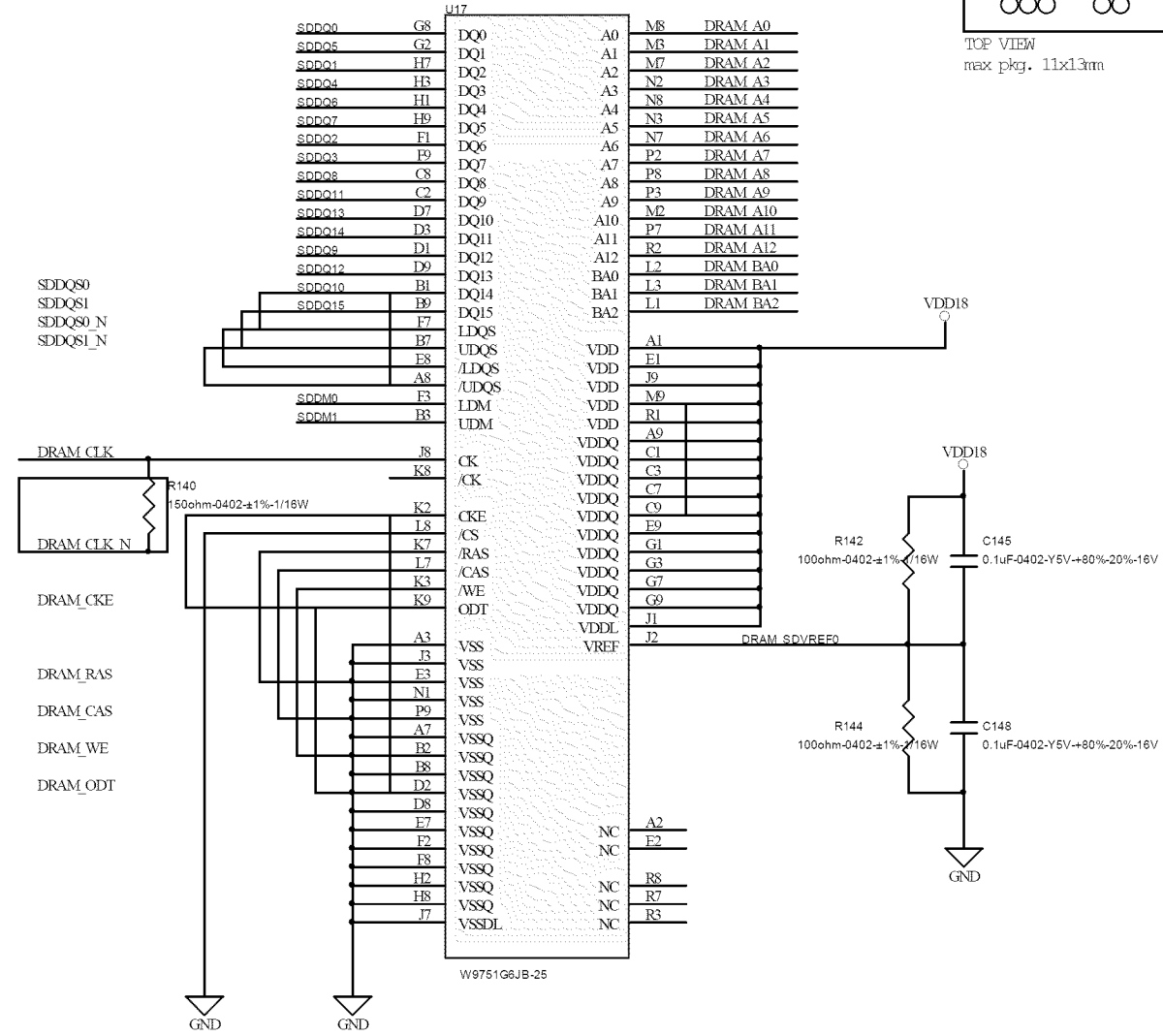
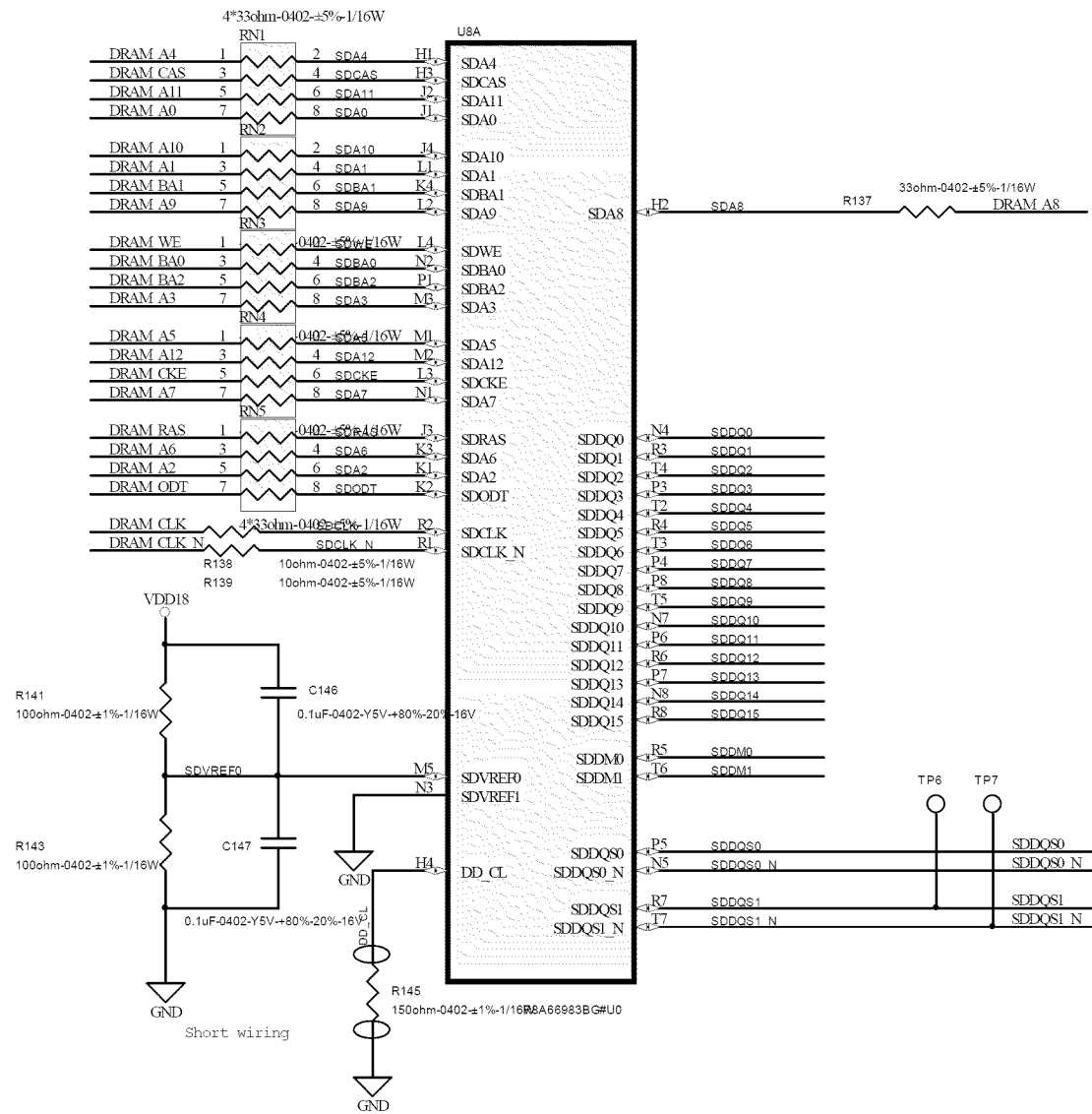

Main Board (SCH)

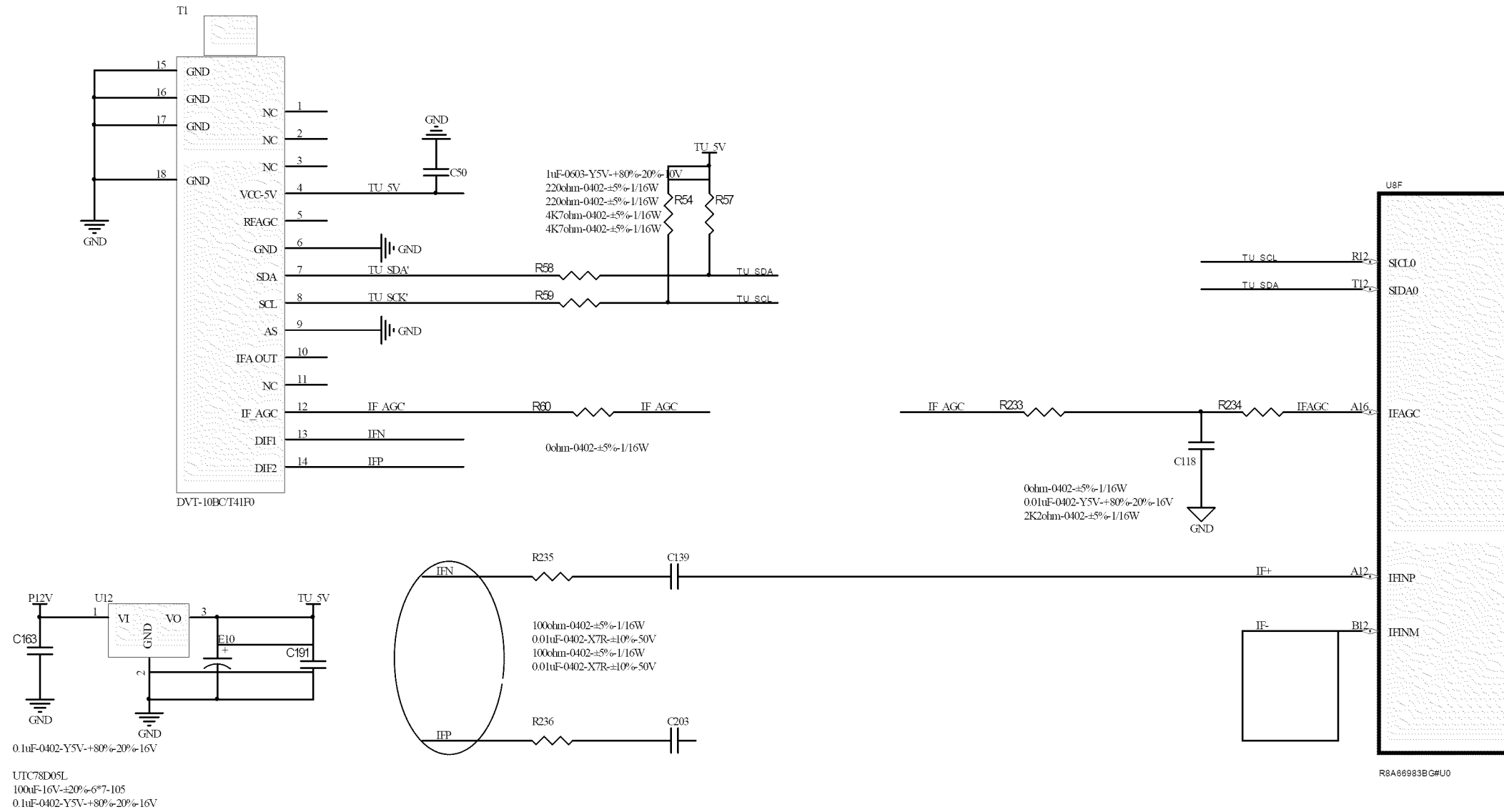

Main Board (SCH)

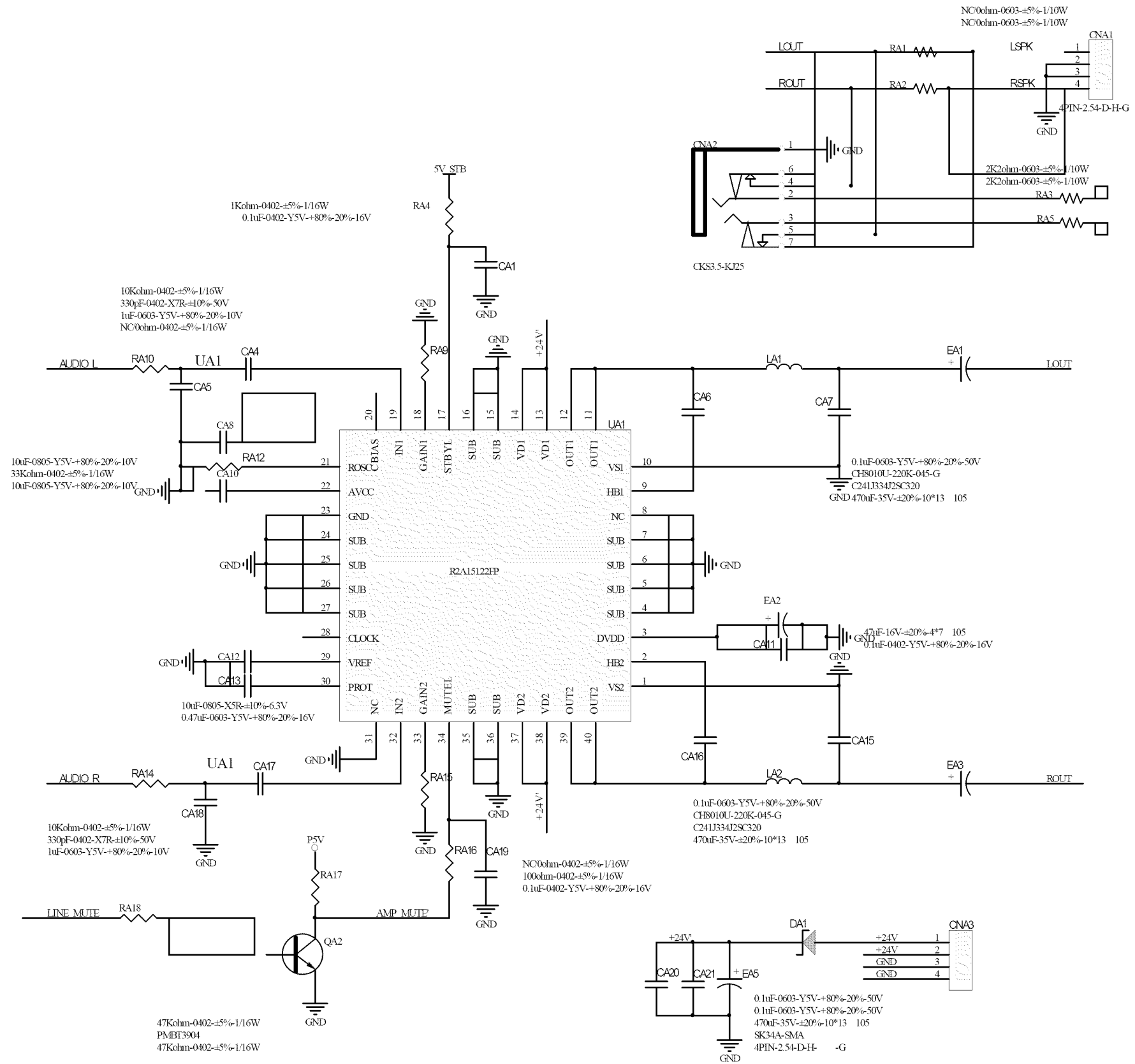

Main Board (SCH)

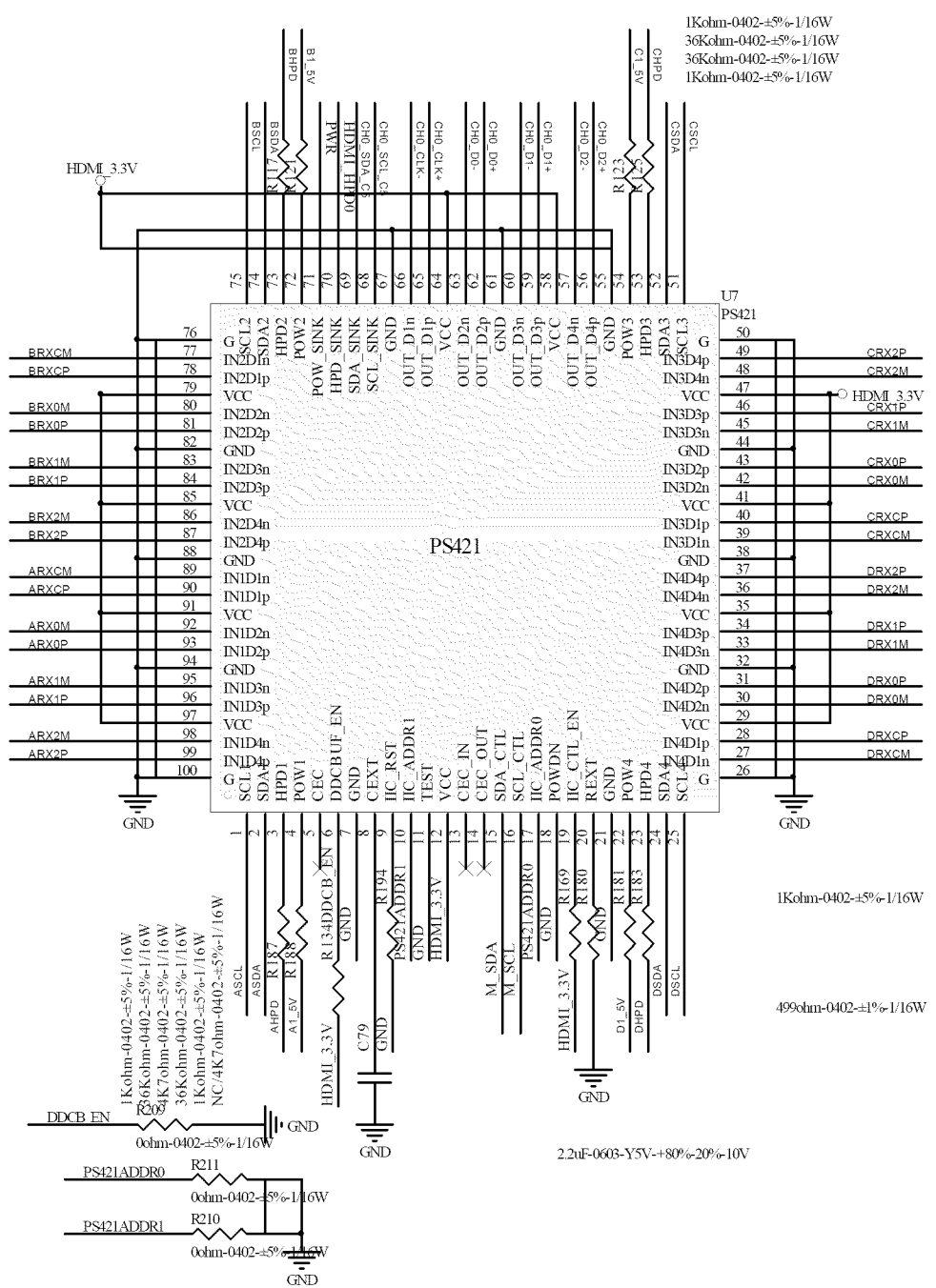
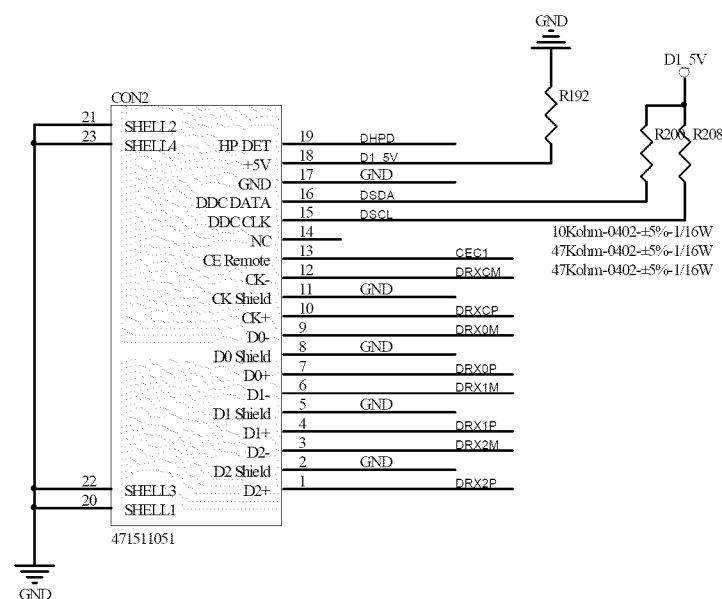
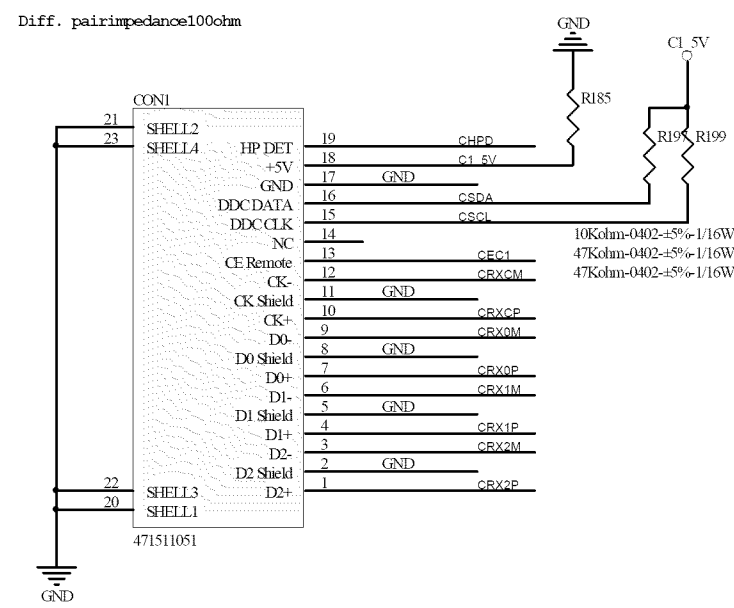
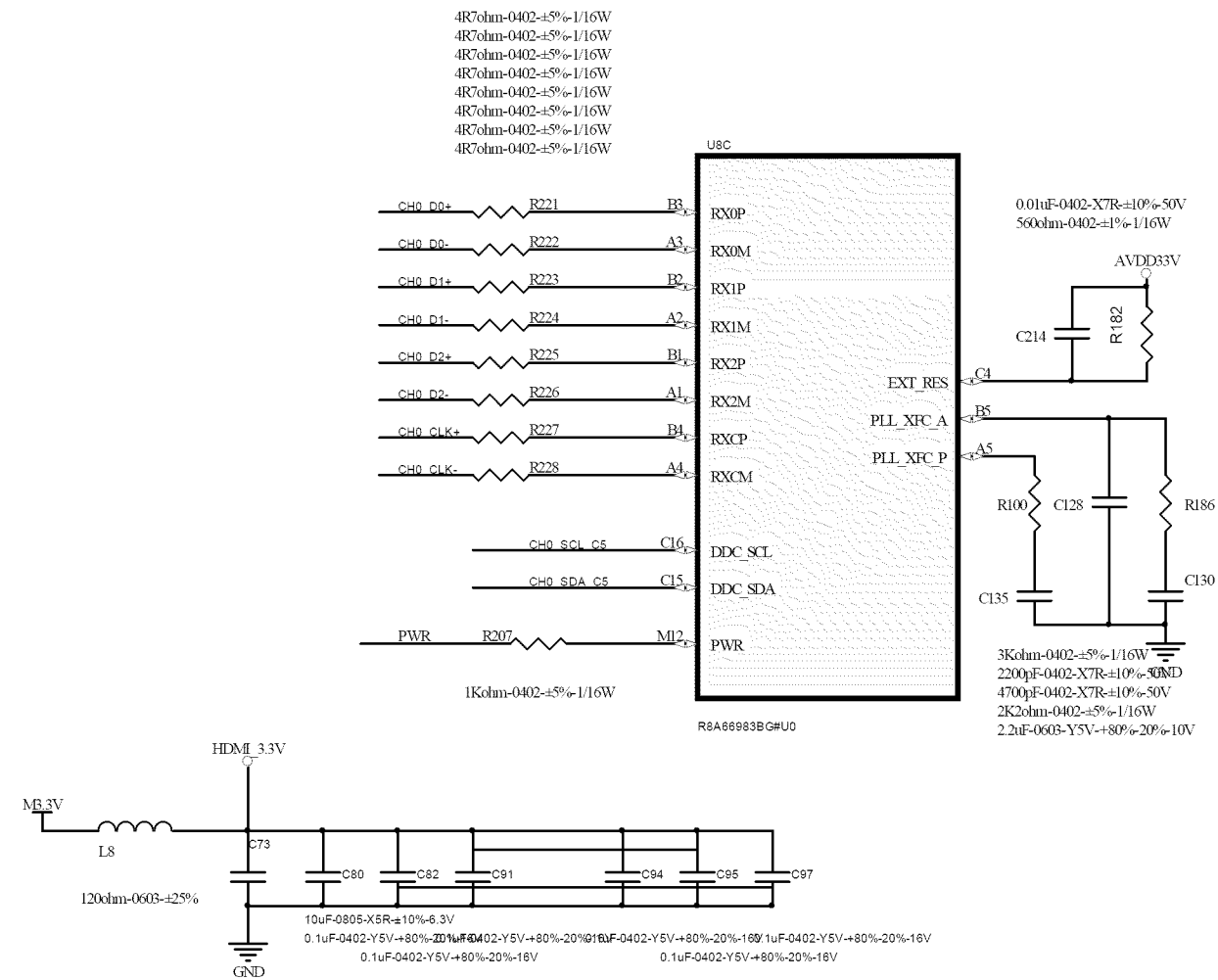
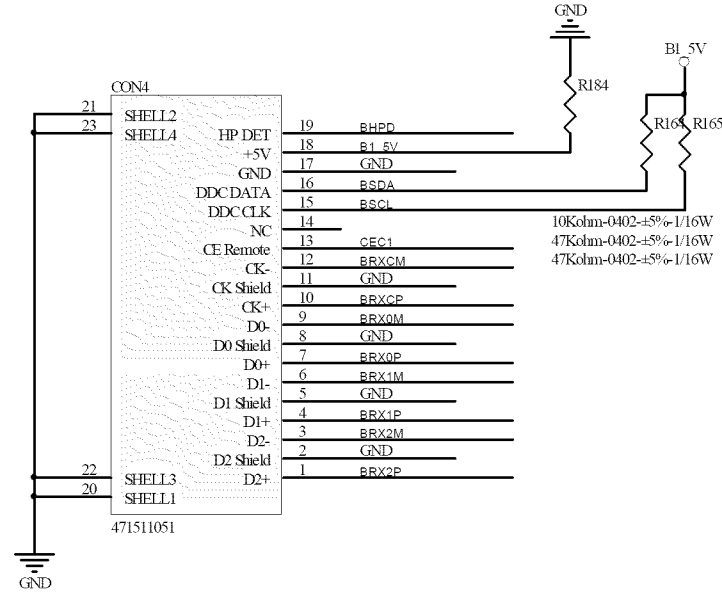
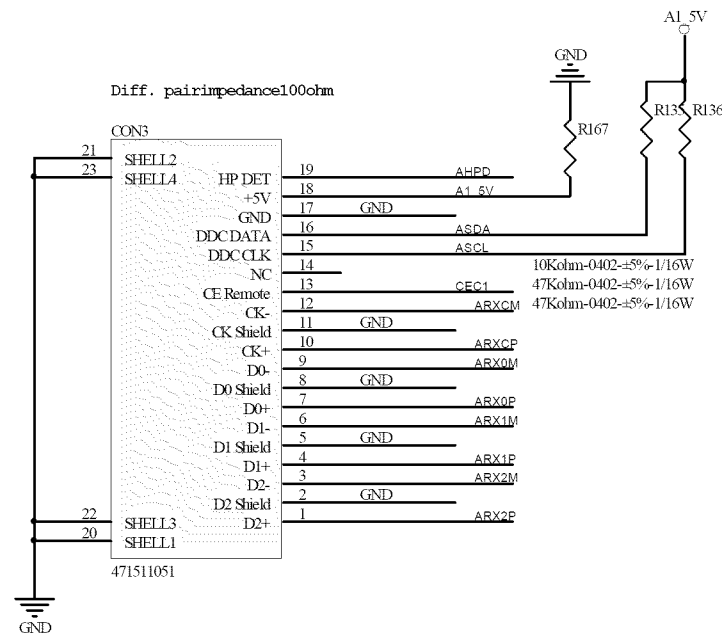

Title		
Size	Number	Revision
A3		
Date:	2011-01-07	Sheet of
File:	D:\ATSC_V10_HDMI_SchDoc	Drawn By:

Power Board (PCB)

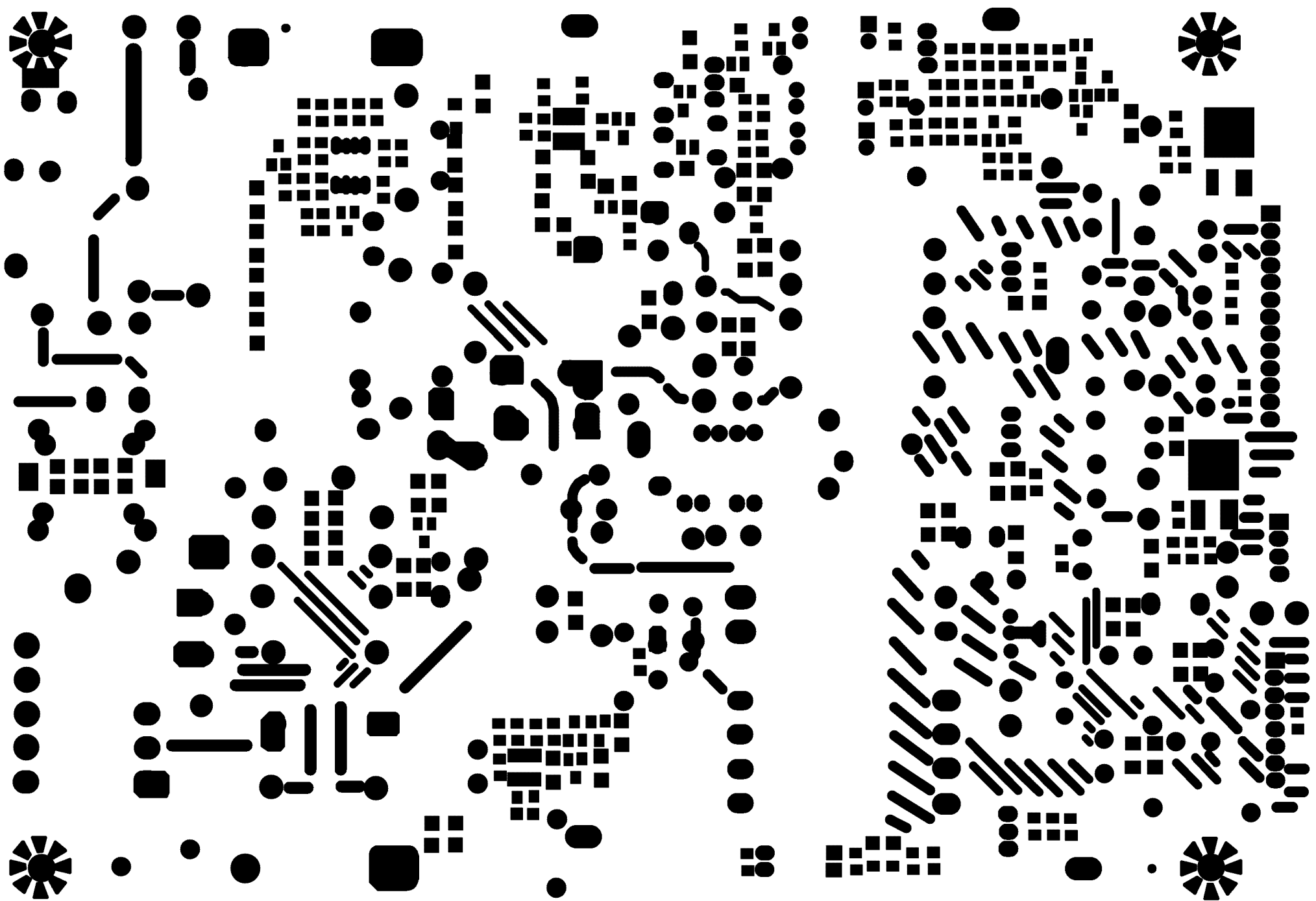

Power Board (PCB)

"HX" P054C042A<AYP418101-029 REV:1.0> CEM-1 1.6T 2009.0901 4PCS "S" 191.5*136MM
AYP418101 REV:1.0

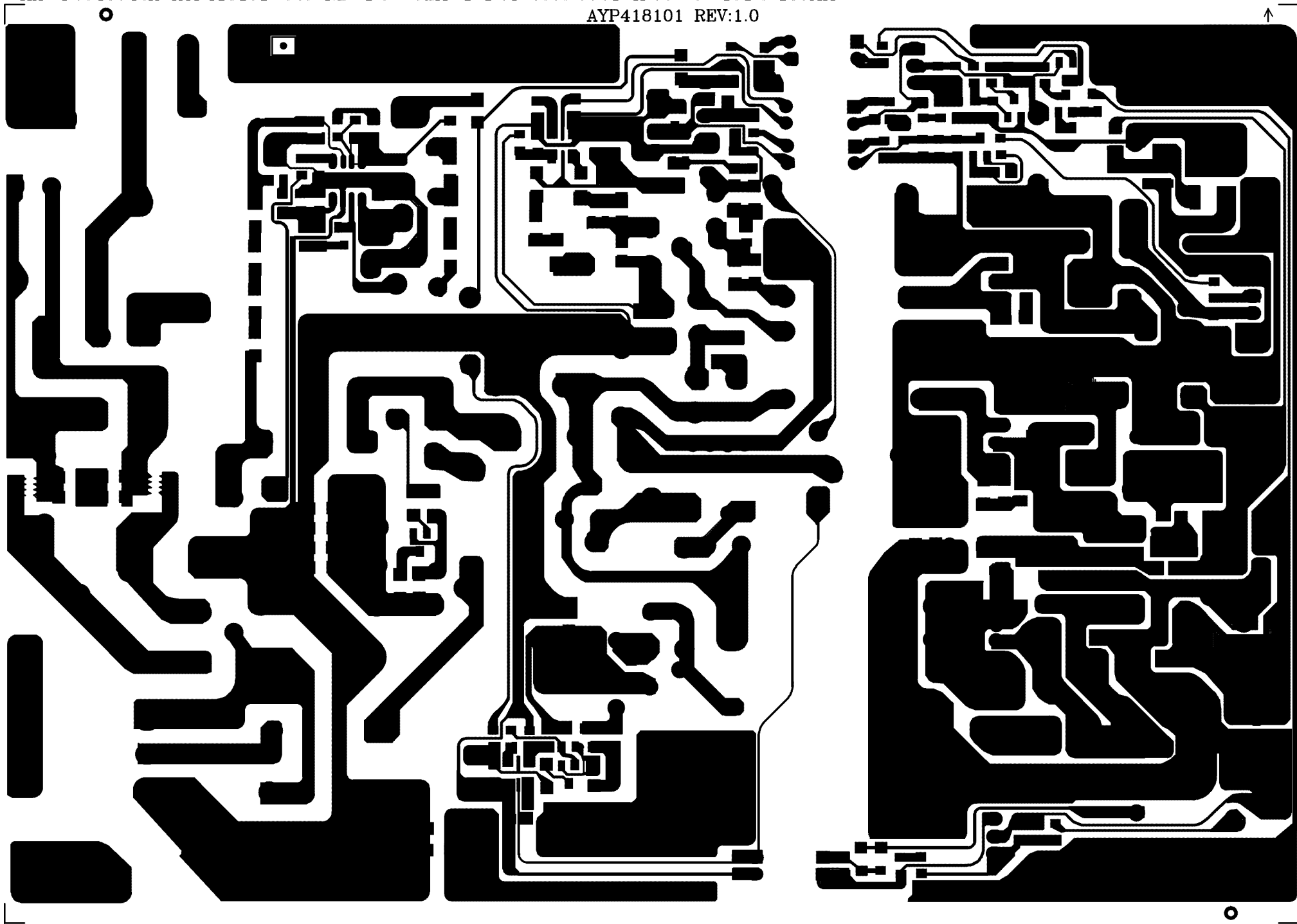

Power Board (PCB)

"HX" P054C042A<AYP418101-029 REV:1.0> CEM-1 1.6T 2009.0808 4PCS "S" 191.5*136MM

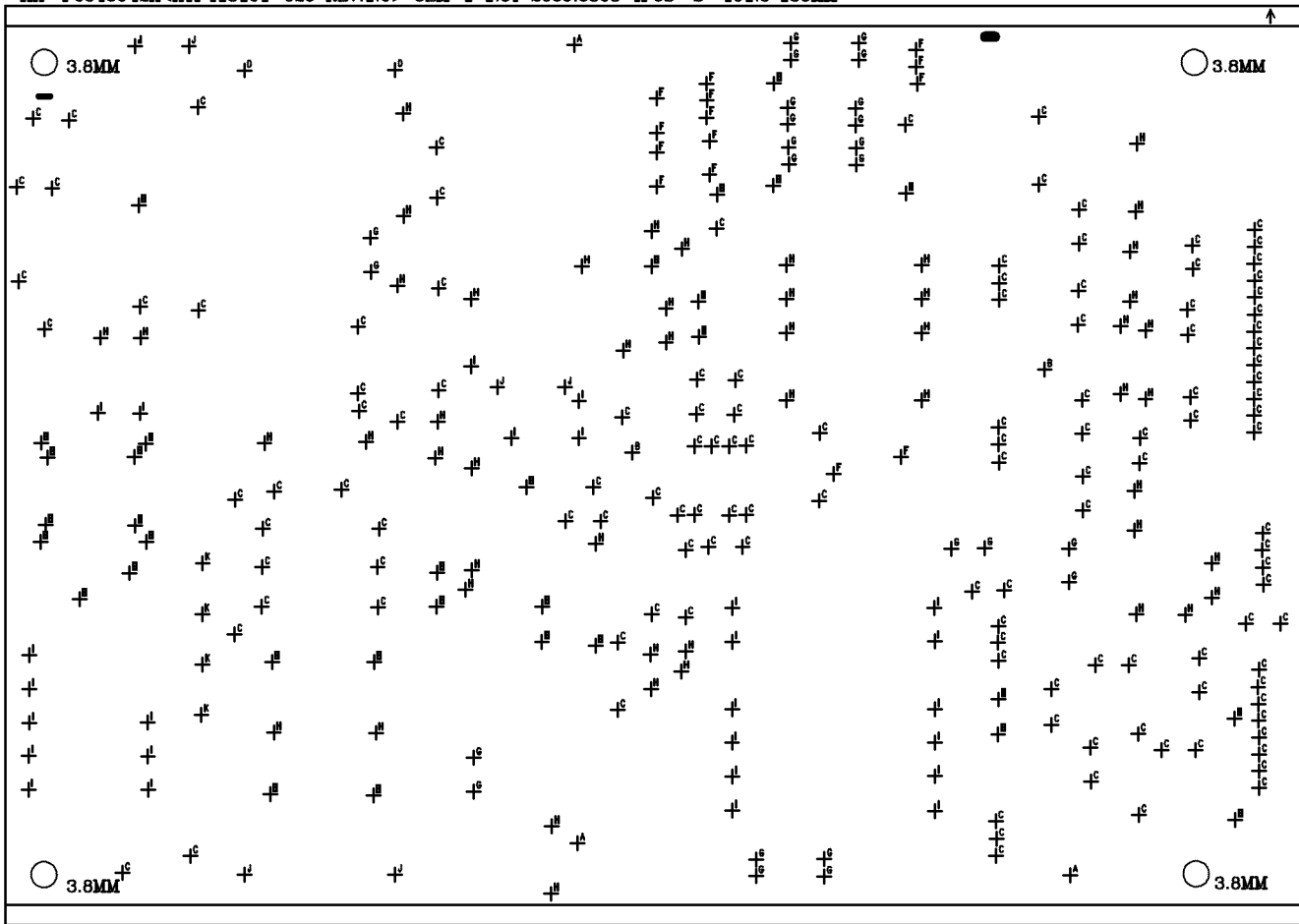

TOOL CHART

No.	Size(MM)	Count	Legend
1	1.8000	3	+
2	2.0000	2	P
3	0.9980	128	F
4	1.9990	2	P
5	1.1000	32	+
6	0.8990	14	+
7	0.8000	24	+
8	1.1990	50	+
9	1.2980	26	+
10	1.7980	6	+
11	1.4990	4	+

26" EXPLORED VIEWING

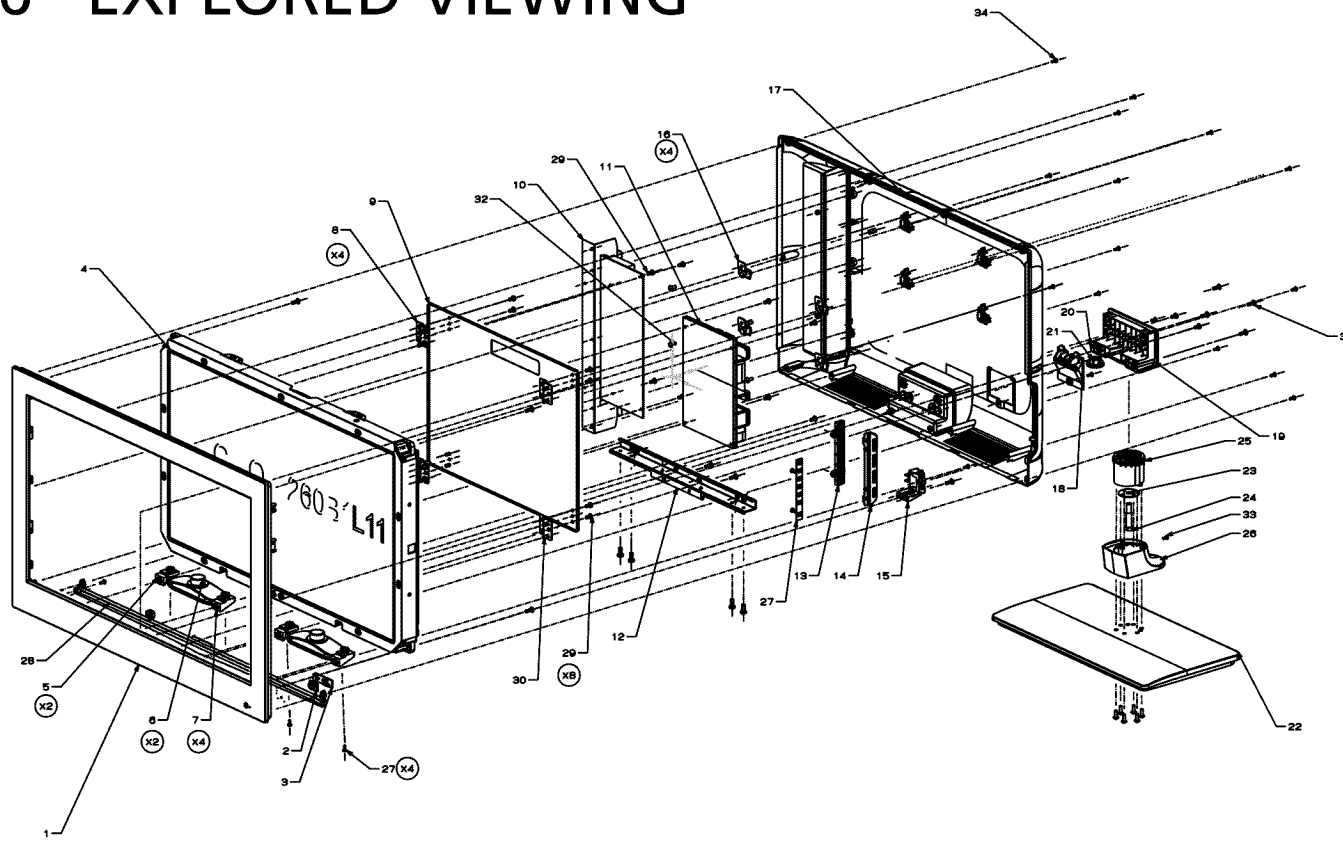

34	ST3XBF	SCREW	24	
33	ST3XBF-5J2B22	SCREW	1	
32	ST4X10F	SCREW	4	
31	ST4X12F	SCREW	17	
30	M5X12	SCREW	12	
29	M4X8	SCREW	18	
28	182897000	Adorning	1	
27	PCB-KEY-3292	Keyboard	1	
26	143298100	Neck cover	1	
25	143298200	Bracket stand	1	
24	430840001	Bolt	1	
23	243292100	Metal washer	1	
22	143292800	Base cover	1	
21	103292000	Nut cover	1	
20	430807001	Nut	1	
19	143298100	Stand neck	1	
18	1842K1500	Cover	1	
17	122898020	Back cabinet	1	
16	282880000	Bracket wallmount	4	
15	183292100	Bracket	1	
14	183292000	Bracket keyboard	1	
13	183292100	Keyboard	1	
12	212898300	Connector	1	
11	PCB-DYB-2898	Power board	1	
10	23329801C10	Shield jack	1	
9	252898000	Bracket	1	
8	213223330	Connector	4	
7	312855001	Rubber	4	
6	Y415-1804	Speaker	2	
5	183292200	Bracket speaker	2	
4	LCB-26-CM-V2800-L11	Panel	1	
3	PCB-1R-4298	IR board	1	
2	171930100	Lens sensor	1	
1	112897000	Front cabinet	1	
No.	Part#	Name	Amount	

