



WIFI REMOTE CONNECTION CRADLE

USER'S GUIDE

ACCWIFI1
Version 1.0

ENGLISH

FRANÇAIS

ESPAÑOL



www.lorexttechnology.com



Safety Precautions

- Adult assembly is required. Keep small parts away from children when assembling.
- This product is not a toy. Do not allow children or infants to play with it.
- Keep the cords out of reach from children and infants.
- Only use the chargers and power adapters provided. Do not use other chargers or power adapters as this may damage the device and battery pack.
- Do not cover the product with a towel or blanket.
- Do not use the product near water.
- Do not install the product near a heat source.
- Do not touch the plug contacts with sharp or metal objects.
- Keep this user's guide for future reference.



To Avoid Injury to Children & Infants:

- **MAKE SURE** to keep the product and all power cords are least 3ft / 1m away from cribs and out of reach of your child.

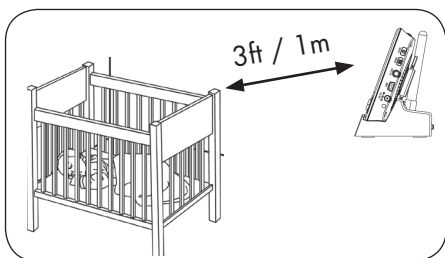
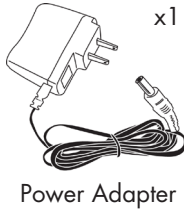
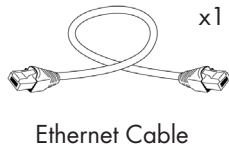
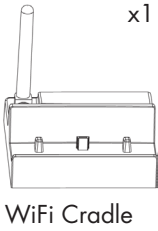

Table of Contents:

Product Includes.....	2
Cradle Overview.....	2
Supported Mobile Devices	2
Getting Started	3
iPhone®/iPad® Ethernet Setup	4
iPhone/iPad WiFi Setup.....	5
Using the iPhone®/iPad® App	7
Live View	7
Zooming in Live View	7
Changing the Cradle Password.....	8
Changing the Video Quality	9
Android Ethernet Setup	10
Android Wi-Fi Setup	12
Using the Android App.....	15
Live View	15
Zooming in Live View	15
Viewing and Sharing Snapshots.....	16
Changing the Cradle Password.....	17
Changing the Video Quality	18
Technical Specifications	20
Cradle.....	20
Troubleshooting	21
Need Help?.....	21

Product Includes



Handheld monitor and camera(s) are sold separately.

Cradle Overview

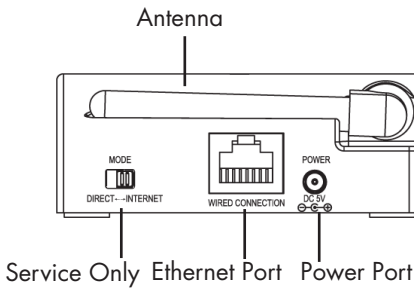
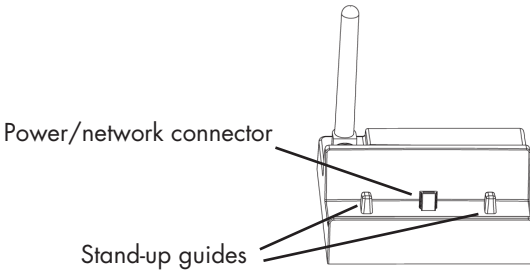

Supported Mobile Devices

Getting Started

- 1 Connect the cradle power adapter to the cradle. Connect the other end to a power outlet.

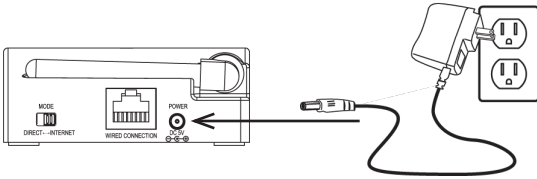

- 3 Connect the cradle to your router using an Ethernet cable (included).

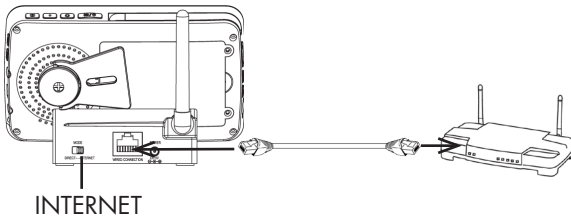

NOTE: Ensure the switch on the back is set to INTERNET mode. DIRECT mode is for service use only.

- 2 Place the monitor onto the power/network connector on the cradle. Use the stand-up guides to help place the monitor.

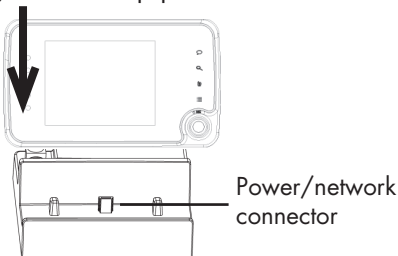

- 4 On your smartphone or tablet, download **Lorex Care** for free from the App StoreSM (iPhone®/iPad®) or the Google Play Store (Android™).

The monitor will charge when connected to the cradle.

The next steps in the setup depend if you are connecting to the cradle using an iPhone®/ iPad® or Android™ device.

For iPhone®/iPad®:

go to page 4

For Android™:

go to page 10

iPhone®/iPad® Ethernet Setup

- 1 Touch the **Lorex Care** icon to launch the app.



- 2 Enter the ID code for the cradle in one of the following ways:

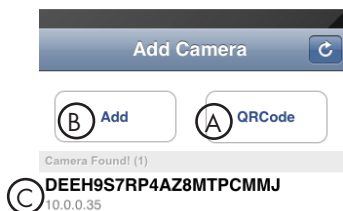

A. Tap **QRCode** and scan the QR code on the side of the cradle using your device's camera.

B. Tap **Add** and manually enter the **UID** printed on the back of the cradle. You may need to do this if your device does not have a camera (for example, 1st generation iPads).

C. If your device is on the same network as the cradle, it will detect the cradle UID. Tap the UID to enter.

- 3

Enter a name for your monitor

Enter the default password **000000**

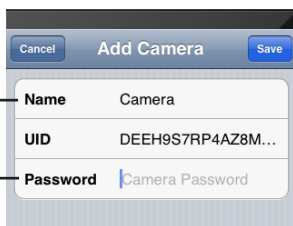

- 4

Tap **Save**

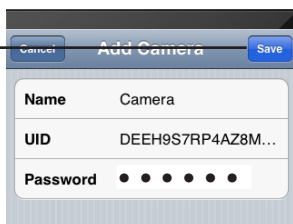

- 5 The monitor will show up in your device list with an Online status.

Tap the monitor to connect

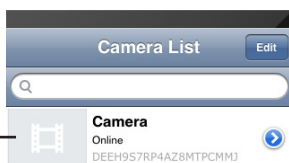

The app will connect to your monitor and stream live video from your cameras.

To connect the cradle to your Wi-Fi network, see below.

iPhone/iPad WiFi Setup

- 1** Open the Camera List screen in **Lorex Care**. Press **Back** if you are currently connected to a camera.

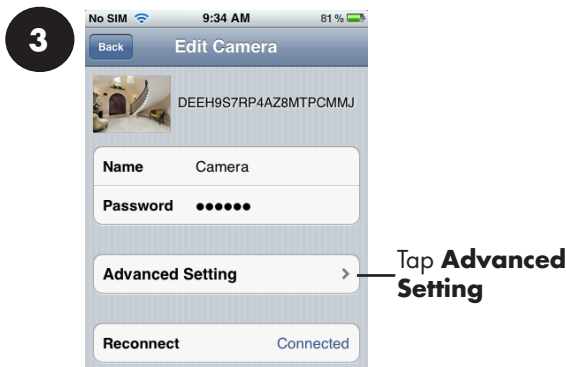
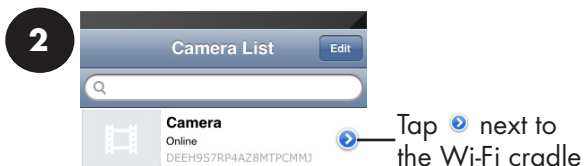

- 5** The cradle will scan for available Wi-Fi networks.

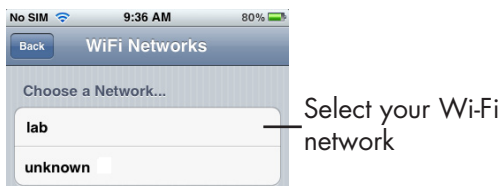

6

Enter the password for your Wi-Fi network

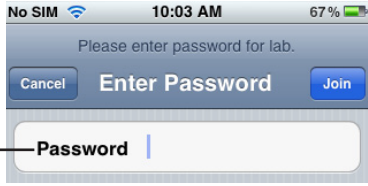

Tap **Join**

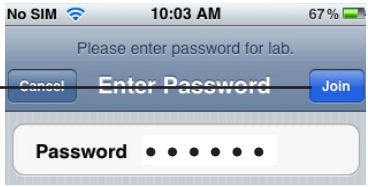

7

Press **Back** 3 times to return to the Camera List.

8

Remove the Ethernet cable from the cradle.

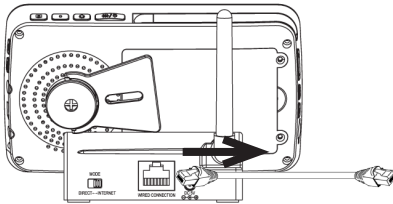

9

Tap the monitor to connect

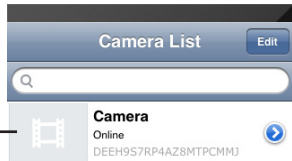

Congratulations! You have successfully connected the cradle to your Wi-Fi network. You can now place the cradle in any location with good signal to your Wi-Fi network.

NOTE: The Wi-Fi cradle must be connected to power and the monitor must be on the cradle to connect to the camera on your phone or tablet.

Using the iPhone®/iPad® App

ENGLISH

Live View

You can view your camera in either portrait or landscape mode.

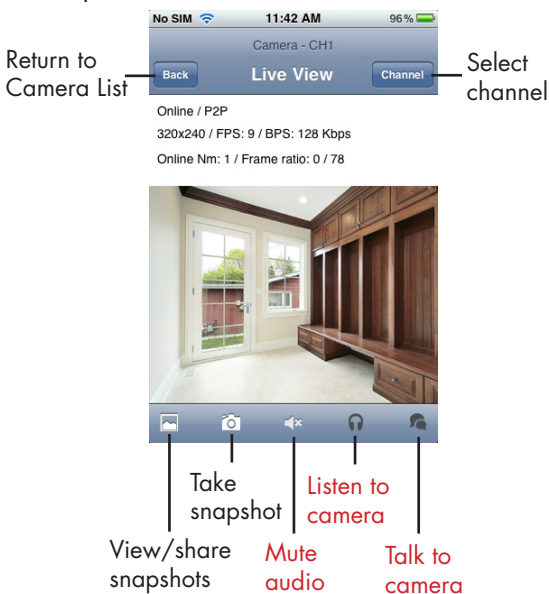

NOTE: The controls above are only shown in portrait mode.

Zooming in Live View

You can zoom in on the video in landscape or portrait mode.

Pinch open to zoom in

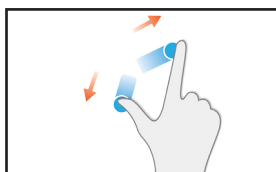

Pinch close to zoom out

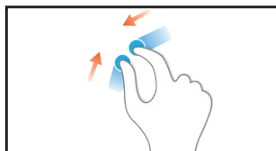

When zoomed in, press and drag to move the zoom area

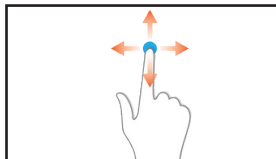

Touch Gesture icons are attributed to the Wikimedia Foundation according to the Creative Commons Licence

Changing the Cradle Password

The default password is **000000**. It is recommended to create your own password to ensure that no one may access your video.

To change the password:

- 1 Open the Camera List screen in **Lorex Care**. Press **Back** if you are currently connected to a camera.

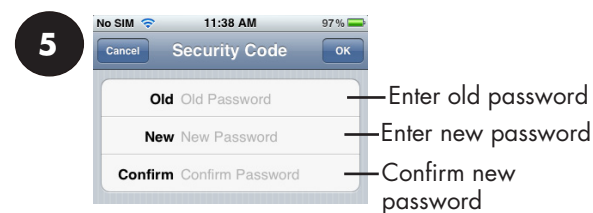
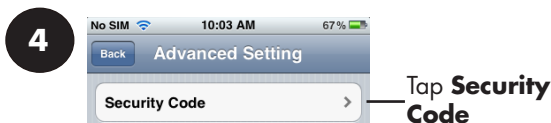
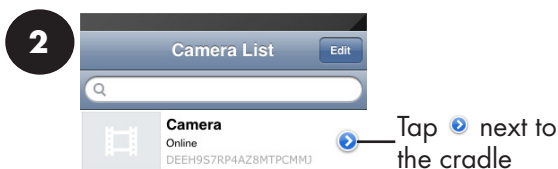

- 6 Tap **OK**. Press **Back** twice times to return to the Camera List.



Changing the Video Quality

The video quality can be increased for fast Internet connections or decreased to improve the video performance.

If the video is choppy or slow, it is recommended to reduce the video quality setting.

To change the video quality:

- 1 Open the Camera List screen in **Lorex Care**. Press **Back** if you are currently connected to a camera.

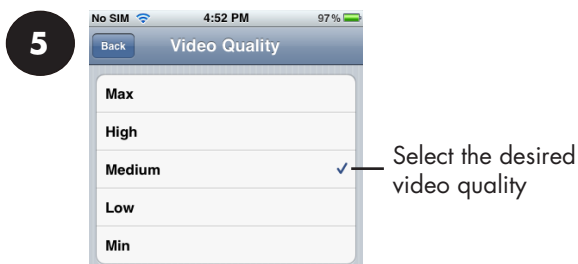
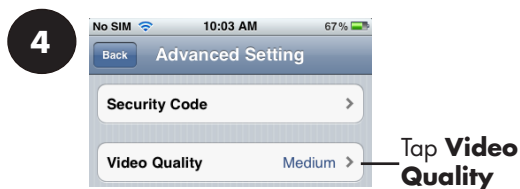
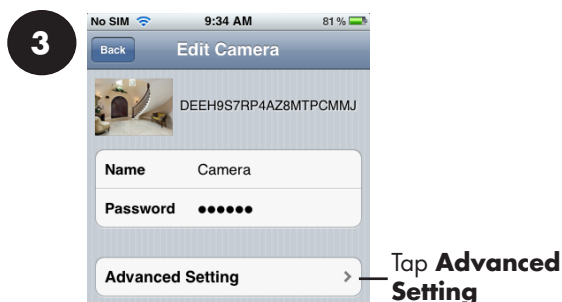
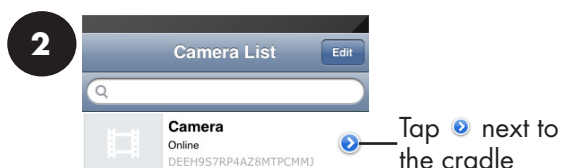

- 6 Tap **Back** three times to return to Camera List.

Android Ethernet Setup

- 1** Touch the **Lorex Care** icon to launch the app.

FPO

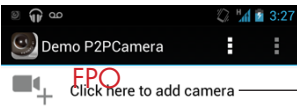
- 2**  Tap **Click here to add camera**.

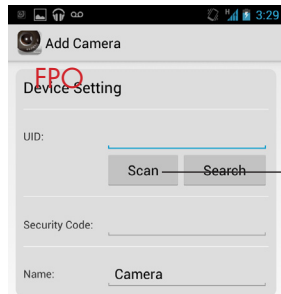
- 3**  Tap **Scan**

Notes

- If your device does not have a camera, you must enter the UID printed on the back of the cradle under **UID**. Then, skip to step 7.
- You may be prompted to select the app that will be used to scan the QR code. Select **Google** and press **Always** to continue.

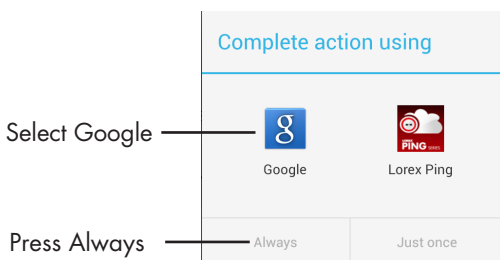

- 4** Line up the QR code on the top of the cradle using the camera on your mobile device.

Line up the QR code using the device's camera

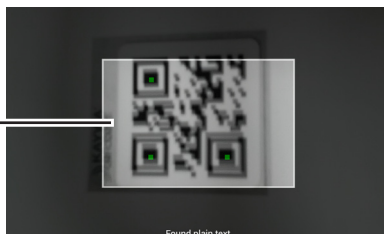

5

Under **Password**, enter the default password **000000**.

6

Under **Name**, enter a name for your monitor.

7

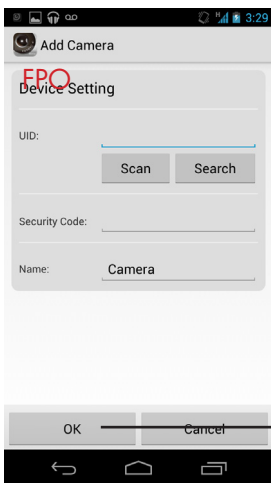

Tap **OK**

8

The monitor will show up in your device list with an Online status.

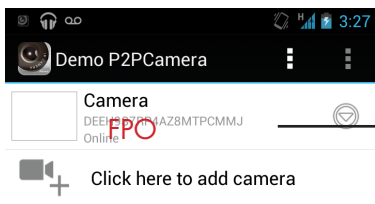

Tap the monitor to connect

The app will connect to your monitor and stream live video from your cameras.

To connect the cradle to your Wi-Fi network, see the next page.

Android Wi-Fi Setup

1 You must connect the cradle to the Internet using an Ethernet cable before you can connect it to your Wi-Fi network. Complete the Ethernet setup as described in "Android Ethernet Setup" on page 10.

2 Open the Camera List screen in **Lorex Care**. Press  if you are currently connected to a camera.

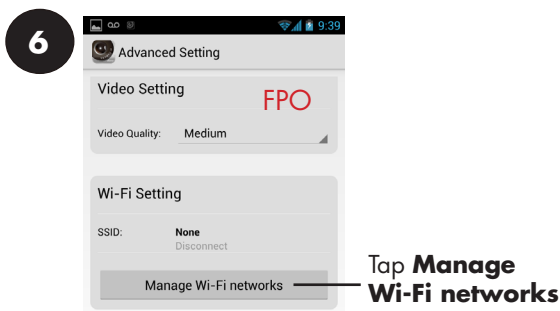
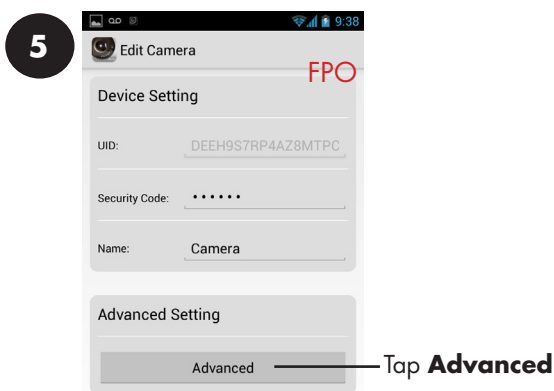
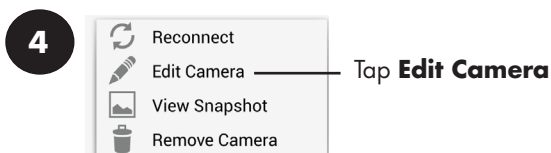
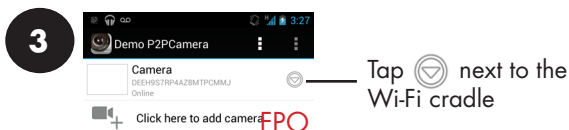

The cradle scans for available Wi-Fi networks.

6 The cradle scans for available Wi-Fi networks.

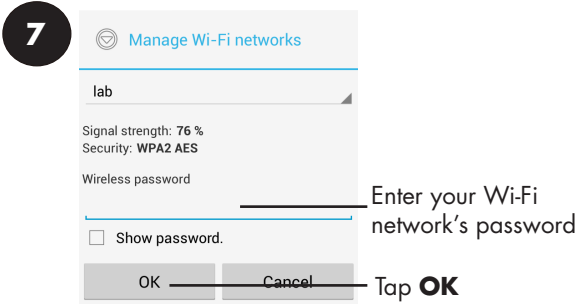
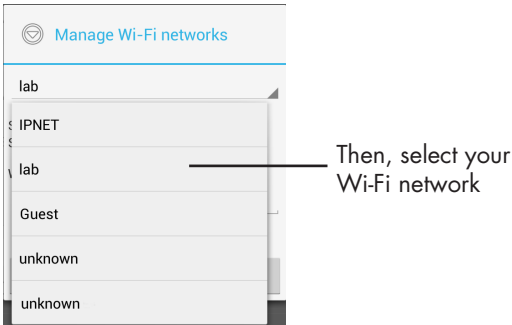
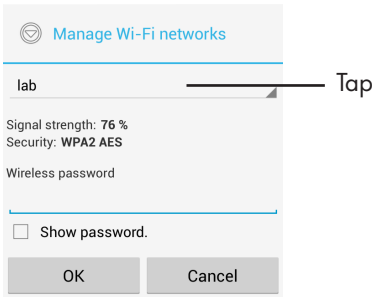

The cradle will connect to your Wi-Fi network. Once connected, it will say Connected below the network name.

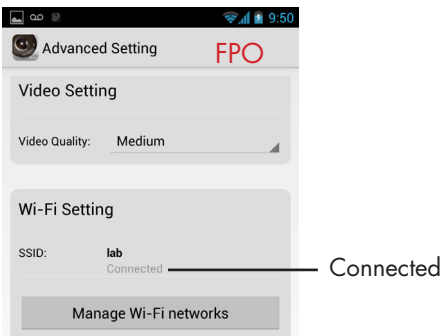

8 Tap **OK** twice to return to the Camera List.

9 Remove the Ethernet cable from the cradle.

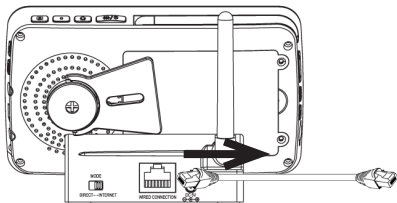

10 Tap to connect to the cradle

A screenshot of a mobile application interface. At the top, the status bar shows the time as 3:27 and various icons. Below the status bar, the app title is "Demo P2PCamera". Underneath, there is a card for a camera with the name "Camera", the ID "DEEH9S7RP4AZ8MTPCMMJ", and the status "Online". To the right of the card is a circular refresh icon. Below the card is a button with a plus sign and the text "Click here to add camera". A line from the text "Tap to connect to the cradle" points to the camera card.

Congratulations! You have successfully connected the cradle to your Wi-Fi network. You can now place the cradle in any location with good signal to your Wi-Fi network.

NOTE: The Wi-Fi cradle must be connected to power and the monitor must be on the cradle to connect to the camera on your phone or tablet.

Using the Android App

Live View

You can view your camera in either portrait or landscape mode.

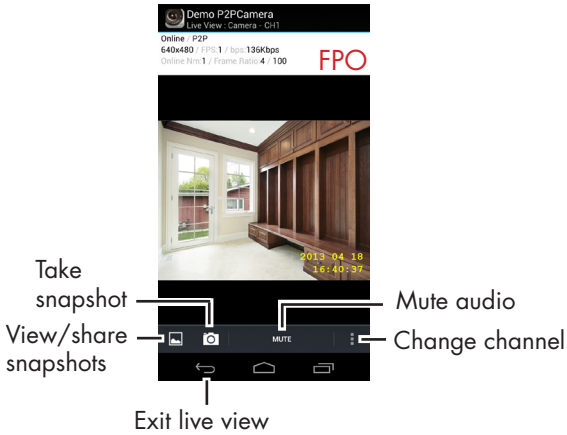

Zooming in Live View

You can zoom in on the video in landscape or portrait mode.

Pinch open to zoom in

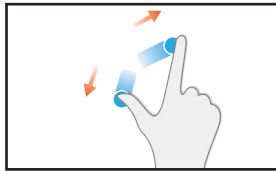

Pinch close to zoom out

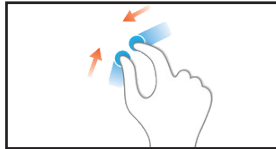

When zoomed in, press and drag to move the zoom area

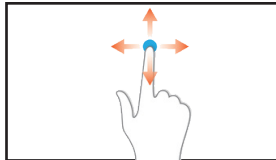

Touch Gesture icons are attributed to the Wikimedia Foundation according to the Creative Commons Licence

Viewing and Sharing Snapshots

You can take snapshots of live video from your cameras by pressing . You can view or share snapshots using the app.

Snapshots are saved in .jpg format. They are saved to the **/DCIM/P2PIPCAM/Snapshot** folder on your device's memory.

To view snapshots:

1

In live view, tap to view snapshots

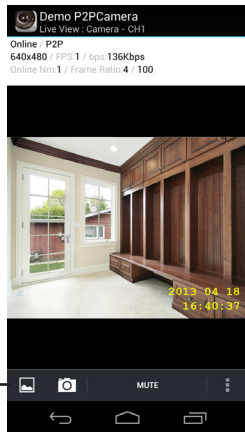

2

Tap to open snapshot

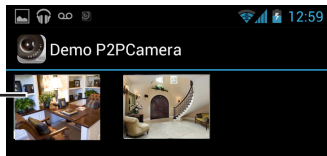

To share snapshots:

1

Tap
Then tap **Share**

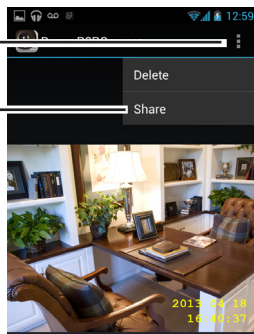

2

Select the app you would like to share the snapshot with and use the app to share the file

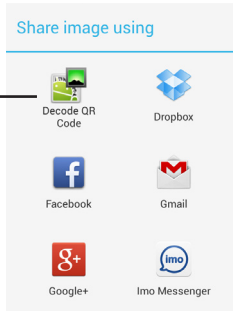

ENGLISH

Lorex does not provide support for apps not published by Lorex.

Changing the Cradle Password

The default password is **000000**. It is recommended to create your own password to ensure that no one may access your video.

To change the password:

1

Open the Camera List screen in **Lorex Care**. Press if you are currently connected to a camera.

2

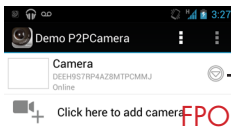

Tap next to the Wi-Fi cradle

3

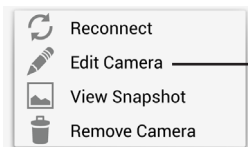

Tap **Edit Camera**

4

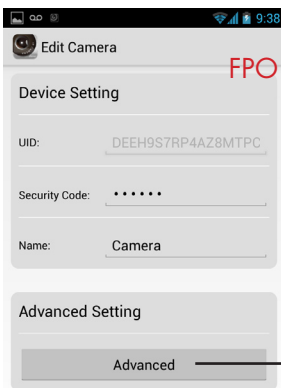

Tap **Advanced**

5

Tap **Modify Security Code**

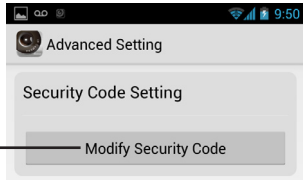

6

Enter old password

Enter new password

Confirm new password

Tap **OK**

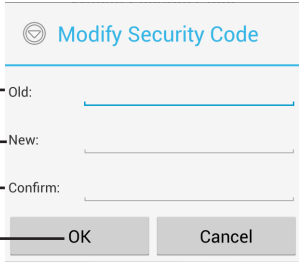

7

Tap **OK** twice to return to Camera List.

8

Tap to connect to the cradle

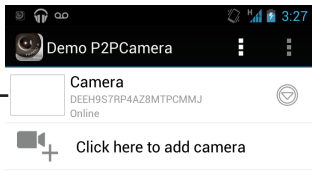

Changing the Video Quality

The video quality can be increased for fast Internet connections or decreased to improve the video performance.

If the video is choppy or slow, it is recommended to reduce the video quality setting.

To change the video quality:

1

Open the Camera List screen in **Lorex Care**. Press  if you are currently connected to a camera.

2

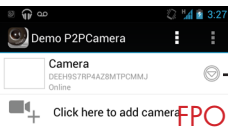

Tap  next to the cradle

3

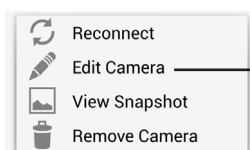
Tap **Edit Camera**

4

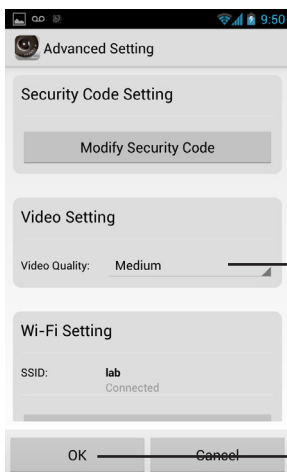
Tap, then select
the desired
video quality

OK

Cancel

Tap **OK**

5

Tap **OK** to return to Camera List.

Technical Specifications

Cradle

Compatible Lorex Products	BB4300 / BB3500 Series LW3400 Series
Wi-Fi	IEEE 802.11 b / g / n
Wi-Fi Encryption	WEP / WPA / WPA2 / WPA2 PSK
Wi-Fi Frequency	2.4GHz
Ethernet	10/100M Ethernet port
DHCP	DHCP Client / Server
Mobile Apps	iOS (v. X.X and higher) Android (v. X.X and higher)
Power Adapter	5.0V DC 1500mA
Weight	0.2lbs / 0.1kg
Operation Temperature	32 ~ 104°F / 0 ~ 40°C

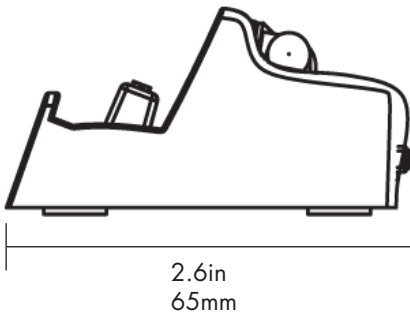
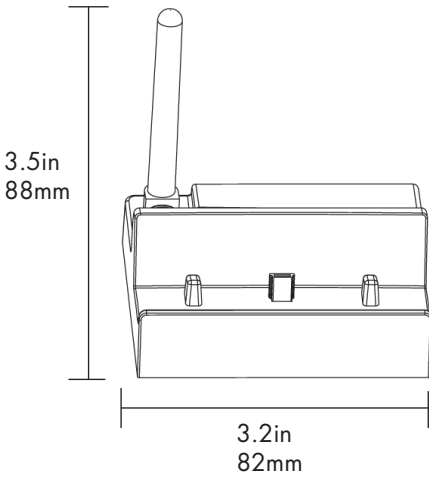

Troubleshooting

Problem	Solution
Cannot connect to the monitor on my smartphone or tablet	<ul style="list-style-type: none">• Monitor is not placed on the cradle. The monitor must be on the cradle to enable remote connectivity.• Cradle is not connected to power. Connect the power adapter to the Wi-Fi cradle.• Ethernet cable not connected or Wi-Fi network not set up. Connect an Ethernet cable to the cradle and connect the other end to your router. For details, see "iPhone®/iPad® Ethernet Setup" on page 4 or "Android Ethernet Setup" on page 10.• Ensure the switch on the back of the cradle is set to INTERNET mode. DIRECT mode is for service use only.
I have forgotten the password to the cradle	<ul style="list-style-type: none">• The default password is 000000.• Press and hold the Reset button on the cradle with a paper clip or other thin object for X seconds to reset the cradle to default settings. This will cause the cradle to forget any configured Wi-Fi networks.
I do not see Live Video controls on the screen in the iPhone®/iPad® app	<ul style="list-style-type: none">• Controls are only shown when the device is held in portrait mode
The video is slow or choppy	<ul style="list-style-type: none">• This can occur if the Internet connection to the cradle is slow. Turn down the Video Quality settings to improve the performance.

Need Help?

Product Support is available 24/7 including product information, user guides, quick start guides, and FAQ's at www.lorextechnology.com/support

CLEANING

Clean the product with a slightly damp cloth or an anti-static cloth. Never use cleaning agents or abrasive solvents.

- Do not clean any part of the product with cleaners with thinners or other solvents and chemicals. This may cause permanent damage to the product, which is not covered by the Warranty. When necessary, clean it with a damp cloth.
- Keep your product away from hot, humid areas or strong sunlight, and do not get it wet.
- Every effort has been made to ensure high standards of reliability for your product. However, if something does go wrong, please do not try to repair it yourself. Contact Customer Service for assistance.

DISPOSAL OF THE DEVICE

At the end of the product life cycle, you should not dispose of this product with normal household waste, but take the product to a collection point for the recycling of electrical and electronic equipment. The symbol on the product, user's guide, and/or box indicates this.



Some of the product materials can be re-used if you take them to a recycling point. By reusing some parts or raw materials from used products you make an important contribution to the protection of the environment.

Please contact your local authorities in case you need more information on the collection points in your area. Dispose of the battery pack in an environmentally-friendly manner according to your local regulations.

NOTICES

WARNING: Any changes or modifications not expressly approved by the grantee of this device could void the user's authority to operate the device.

FCC NOTICE

This device complies with Part 15, subpart C, of the FCC Rules. Operation is subject to the following two conditions: (1) this device may not cause harmful interference, and (2) this device must accept any interference received, including interference that may cause undesired operation.

The manufacturer is not responsible for any radio or TV interference caused by unauthorized modifications to this equipment. Such modifications could void the user's authority to operate the equipment. However, it is imperative that the user follows the guidelines in this manual to avoid improper usage which may result in damage to the unit, electrical shock and fire hazard injury.

CAUTION: To maintain compliance with the FCC's RF exposure guidelines, place the product at least 20cm (7.87in) from nearby persons.

CANADA/IC NOTICE

This device complies with Industry Canada licence-exempt RSS standard(s). Operation is subject to the following two conditions: (1) this device may not cause interference, and (2) this device must accept any interference, including interference that may cause undesired operation of the device.



USER'S GUIDE
ACCWIFI1
Version 1.0

www.lorexttechnology.com

Copyright © Lorex Technology Inc. 2013