

Reebok® 3500C

Model No. RBTL091040

Serial No. _____

Write the serial number in the space above for future reference.

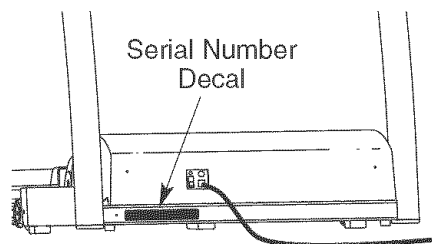

USER'S MANUAL

QUESTIONS?

If you have questions, or if there are missing parts, we will guarantee complete satisfaction through direct assistance from our factory.

TO AVOID DELAYS, PLEASE CALL DIRECT TO OUR TOLL-FREE CUSTOMER HOT LINE.

The trained technicians on our customer hot line will provide immediate assistance, free of charge.

CUSTOMER HOT LINE:

1-877-994-4999

Mon.-Fri., 6 a.m.-6 p.m. MST

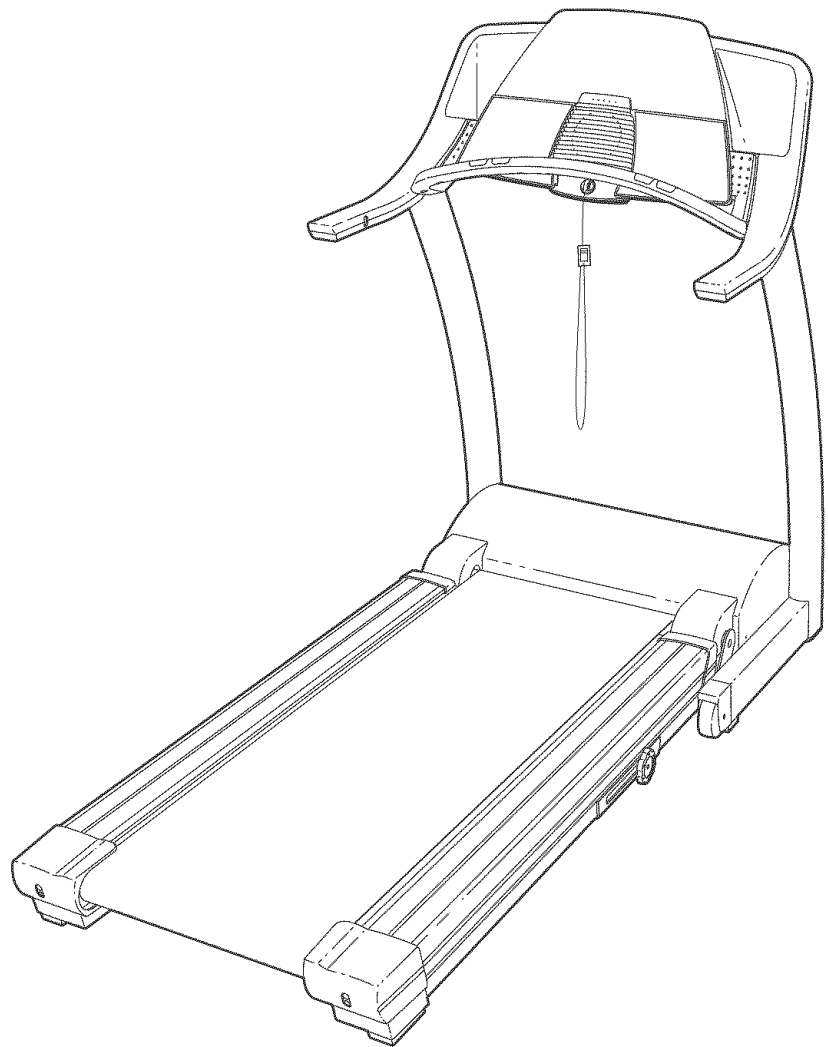

▲ CAUTION

Read all precautions and instructions in this manual before using this equipment. Save this manual for future reference.



Visit our website at

www.reebokhomefitness.com

*new products, prizes,
fitness tips, and much more!*

Reebok® 3500C

TABLE OF CONTENTS

| | |
|--|------------|
| IMPORTANT PRECAUTIONS | .3 |
| BEFORE YOU BEGIN | .5 |
| ASSEMBLY | .6 |
| TREADMILL OPERATION | .8 |
| HOW TO FOLD AND MOVE THE TREADMILL | .24 |
| TROUBLESHOOTING | .26 |
| EXERCISE GUIDELINES | .28 |
| PART LIST | .30 |
| HOW TO ORDER REPLACEMENT PARTS | .31 |
| LIMITED WARRANTY | Back Cover |

Note: An EXPLODED DRAWING is attached in the center of this manual.

IMPORTANT PRECAUTIONS

⚠ WARNING: To reduce the risk of burns, fire, electric shock, or injury to persons, read the following important precautions and information before operating the treadmill.

1. It is the responsibility of the owner to ensure that all users of this treadmill are adequately informed of all warnings and precautions.
2. Use the treadmill only as described in this manual.
3. Place the treadmill on a level surface, with at least eight feet of clearance behind it and two feet on each side. Do not place the treadmill on any surface that blocks air openings. To protect the floor or carpet from damage, place a mat under the treadmill.
4. Keep the treadmill indoors, away from moisture and dust. Do not put the treadmill in a garage or covered patio, or near water.
5. Do not operate the treadmill where aerosol products are used or oxygen is administered.
6. Keep children under the age of 12 and pets away from the treadmill at all times.
7. The treadmill should not be used by persons weighing more than 250 pounds. Never allow more than one person on the treadmill at a time.
8. Wear appropriate exercise clothes when using the treadmill. Do not wear loose clothes that could become caught in the treadmill. Athletic support clothes are recommended for both men and women. *Always wear athletic shoes. Never use the treadmill with bare feet, wearing only stockings, or in sandals.*
9. When connecting the power cord (see page 8), plug the power cord into a surge suppressor (not included) and plug the surge suppressor into a grounded circuit capable of carrying 15 or more amps. No other appliance should be on the same circuit. Do not use an extension cord.
10. Use only a single-outlet surge suppressor that meets all of the specifications described on page 10. To purchase a surge suppressor, see your local REEBOK dealer or call 1-877-994-4999 and order part number 146148.
11. Failure to use a properly functioning surge suppressor could result in damage to the control system of the treadmill. If the control system is damaged, the walking belt may change speed or stop unexpectedly, which may result in a fall and serious injury.
12. Keep the power cord and the surge suppressor away from heated surfaces.
13. Never move the walking belt while the power is turned off. Do not operate the treadmill if the power cord or plug is damaged, or if the treadmill is not working properly. (See **BEFORE YOU BEGIN** on page 5 if the treadmill is not working properly.)
14. Never start the treadmill while you are standing on the walking belt. Always hold the handrails while using the treadmill.
15. The treadmill is capable of high speeds. Adjust the speed in small increments to avoid sudden jumps in speed.
16. The pulse sensor is not a medical device. Various factors, including the user's movement, may affect the accuracy of heart rate readings. The pulse sensor is intended only as an exercise aid in determining heart rate trends in general.
17. Never leave the treadmill unattended while it is running. Always remove the key, unplug the power cord and move the reset/off circuit breaker to the off position when the treadmill is not in use. (See the drawing on page 5 for the location of the circuit breaker.)
18. Do not attempt to raise, lower, or move the treadmill until it is properly assembled. (See **ASSEMBLY** on page 6, and **HOW TO FOLD AND MOVE THE TREADMILL** on page 24.) You must be able to safely lift 45 pounds (20 kg) to raise, lower, or move the treadmill.
19. When folding or moving the treadmill, make sure that the storage latch is fully closed.

20. When using iFIT.com CDs and videos, an electronic “chirping” sound will alert you when the speed and/or incline of the treadmill is about to change. Always listen for the “chirp” and be prepared for speed and/or incline changes. In some instances, the speed and/or incline may change before the personal trainer describes the change.

21. When using iFIT.com CDs and videos, you can manually override the speed and incline settings at any time by pressing the speed and incline buttons. However, when the next “chirp” is heard, the speed and/or incline will change to the next settings of the CD or video program.

22. Always remove iFIT.com CDs and videos from your CD player or VCR when you are not using them.

23. Inspect and properly tighten all parts of the treadmill every three months.

24. Never drop or insert any object into any opening.

25. **DANGER:** Always unplug the power cord immediately after use, before cleaning the treadmill, and before performing the maintenance and adjustment procedures described in this manual. Never remove the motor hood unless instructed to do so by an authorized service representative. Servicing other than the procedures in this manual should be performed by an authorized service representative only.

26. The treadmill is intended for in-home use only. Do not use the treadmill in any commercial, rental, or institutional setting.



⚠ WARNING: Before beginning this or any exercise program, consult your physician. This is especially important for persons over the age of 35 or persons with pre-existing health problems. Read all instructions before using. ICON assumes no responsibility for personal injury or property damage sustained by or through the use of this product.

SAVE THESE INSTRUCTIONS

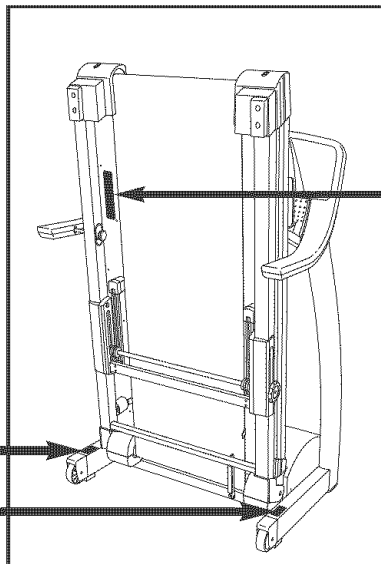
The decals shown below have been placed on your treadmill. If the decal is missing, or if it is not legible, please call our Customer Service Department, toll-free, to order a free replacement decal (see ORDERING REPLACEMENT PARTS on the back cover of this manual). Apply the decal in the location shown. Note: The decals are not shown at actual size.



⚠ WARNING:
Protect yourself and others from risk of serious injury. Read the user's manual and :

-  •Stand only on the side rails when starting or stopping treadmill.
- Change speed in small increments.
- Hold handrails to prevent falling, and always wear the safety clip while operating treadmill.
- Stop if you feel faint, dizzy, or short of breath.
- Fully engage storage latch before treadmill is moved or stored.
- Reduce incline to its lowest level before folding treadmill into storage position.
-  •Never allow children on or around treadmill.
- Remove key when not in use.
-  •Keep clothing, fingers, and hair away from moving belt.
- Never try to adjust or fix the belt while it is moving.
- Always wear athletic shoes while operating treadmill.

BEFORE YOU BEGIN

Congratulations for purchasing the REEBOK® 3500C treadmill. The 3500C treadmill offers an impressive array of features to help you achieve your fitness goals in the convenience of your home. From the advanced console to the cushioned walking platform, the 3500C treadmill is designed to make each workout more effective and enjoyable. And when you're not exercising, the treadmill can be folded away, taking less than half the floor space of conventional treadmills.

For your benefit, read this manual carefully before using the treadmill. If you have questions after read-

ing this manual, please call our Customer Service Department toll-free at 1-877-994-4999, Monday through Friday, 6 a.m. until 6 p.m. Mountain Time (excluding holidays). To help us assist you, please note the product model number and serial number before calling. The model number of the treadmill is RBTLO91040. The serial number can be found on a decal attached to the treadmill (see the front cover of this manual for the location).

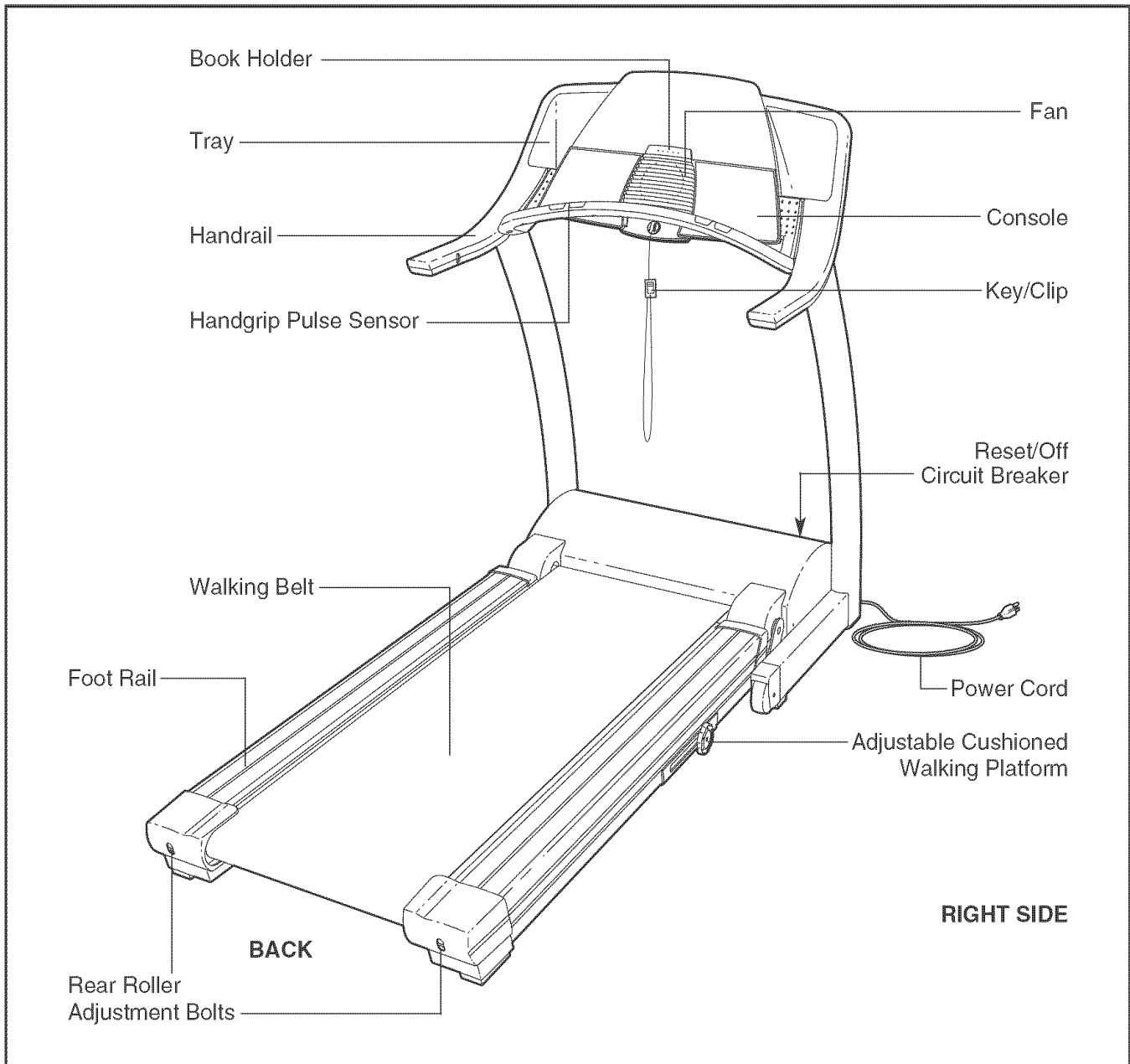

Before reading further, please familiarize yourself with the parts that are labeled in the drawing below.



ASSEMBLY

Assembly requires two persons. Place the treadmill in a cleared area and remove all packing materials. Do not dispose of the packing materials until the treadmill is assembled.

Note: The underside of the treadmill walking belt is coated with high-performance lubricant. During shipping, a small amount of lubricant may be transferred to the top of the walking belt, the sides of the walking platform, or the shipping carton. This does not affect treadmill performance. If there is lubricant on top of the walking belt or on the sides of the walking platform, wipe off the lubricant with a soft cloth and a mild, non-abrasive cleaner.

Assembly requires a phillips screwdriver  **and the included allen wrench** .

1. With the help of a second person, carefully raise the Uprights (65) to a vertical position.

Have the second person hold the console assembly near the Uprights (65) as shown. Look under the console assembly and locate the Console Wire Harness (71).

Cut the plastic ties securing the Upright Wire Harness (85) to the right Upright (65). Connect the Upright Wire Harness to the Console Wire Harness (71). **Make sure to connect the connectors properly (see the inset drawing). The connectors should slide together easily and snap into place.** If the connectors do not slide together easily and snap into place, turn one connector and try again. **IF THE CONNECTORS ARE NOT CONNECTED PROPERLY, THE CONSOLE MAY BE DAMAGED WHEN THE POWER IS TURNED ON.**

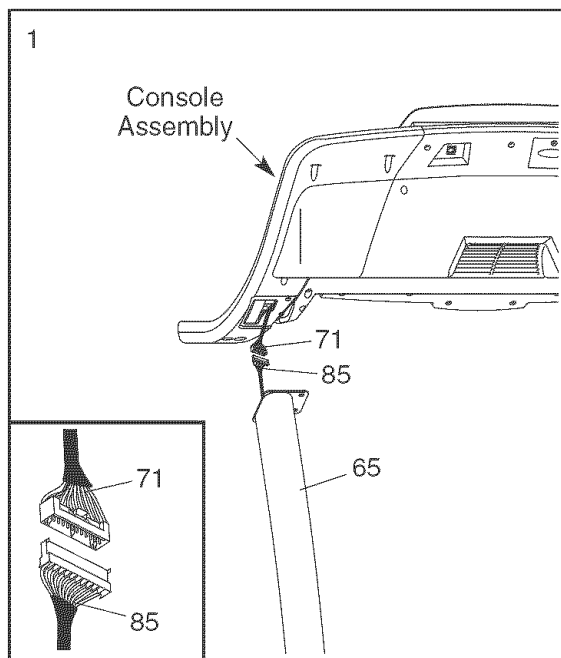

2. Insert the excess Wire Harnesses (71, 85) into the right Upright (65).

Set the console assembly on the Uprights (65). While a second person holds the console assembly, attach the console assembly with four Console Bolts (133) and four Console Washers (69) as shown. Firmly tighten the Console Bolts.

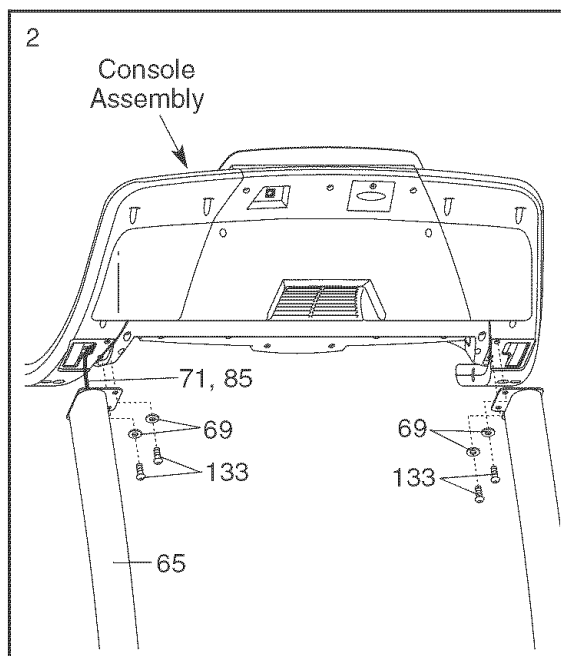

- With the help of a second person, raise the treadmill Frame (55). Hold the Latch Housing (68) and the Latch Housing Cover (5) against the sides of the Frame as shown. Loosely thread the two blunt-tipped 1/2" Screws (132) into the Latch Housing Cover and the Latch Housing as shown. **Do not tighten the Screws yet.**

Remove the knob from the pin. Make sure that the collar and the spring are on the pin. The collar should be on the side of the spring shown. Insert the pin into the Latch Housing (68), and tighten the knob back onto it.

Align the pin with the hole in the Left Handgrip (140) by sliding the Latch Housing (68) up or down. Make sure that the pin can be inserted fully into the hole. Hold the Latch Housing in place as you tighten two 1/2" Tek Screws (143) into the Latch Housing and the Frame (55). Then, tighten the 1/2" Screws (132). Note: It may be necessary to pull on the knob to access and tighten the Screws.

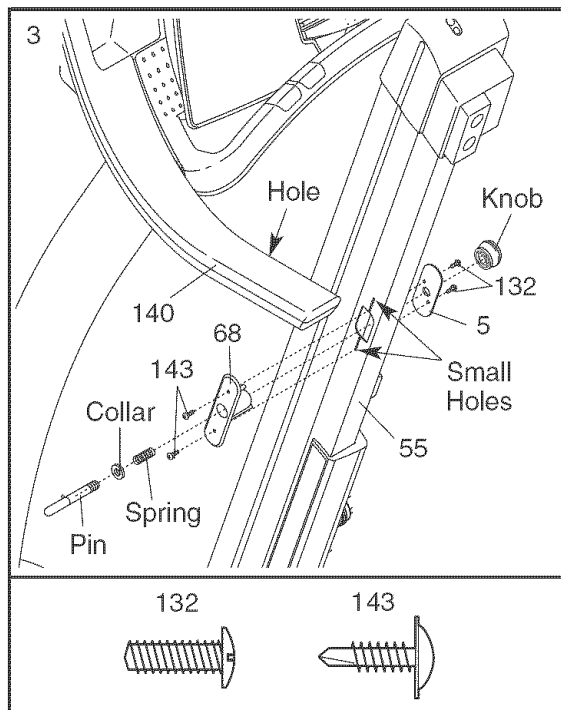

- Remove the backing from the indicated tape on the console assembly. Press the Book Holder (142) firmly onto the tape. Note: The Book Holder may be preassembled.

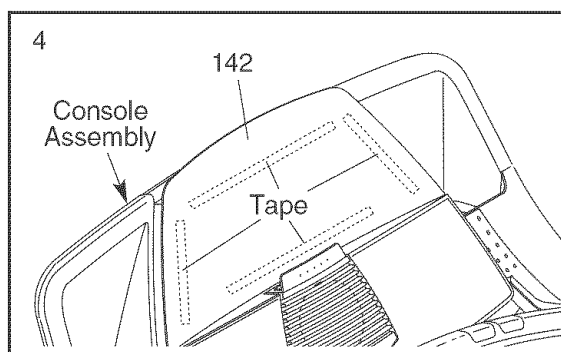

- Make sure that all parts are properly tightened before you use the treadmill. Place a mat beneath the treadmill to protect the floor or carpet.** For your benefit, we recommend that you familiarize yourself with the TROUBLESHOOTING section on pages 26 and 27.

If you purchase the optional chest pulse sensor (see page 23), follow the steps below to install the receiver included with the chest pulse sensor.

- Make sure that the power cord is unplugged.** Remove the indicated Screw (40) and the Access Door (135).
- Remove the paper from the adhesive pad on the back of the receiver (A). **Orient the receiver so the small cylinder is near the lower edge of the receiver and is facing the Console Back (117) as shown.** Firmly press the receiver onto the indicated corner of the Access Door (135). Connect the wire on the receiver to the Pulse Wire (101) extending from the Console Back.
- Make sure that no wires are pinched.** Reattach the Access Door (135) with the Screw (40). Note: The other wires included with the receiver may be discarded.

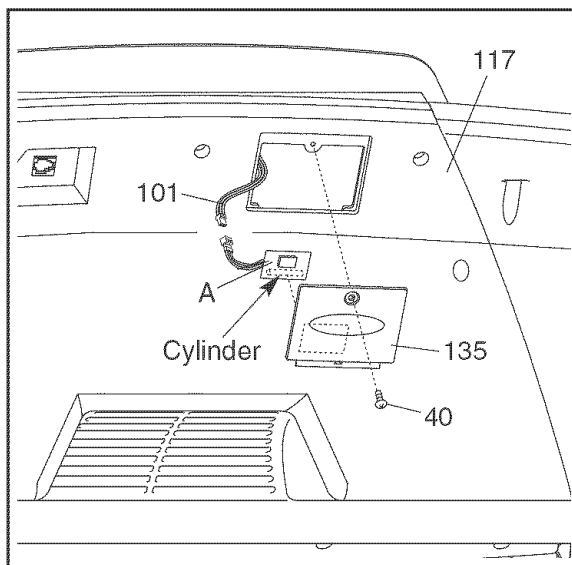

TREADMILL OPERATION

THE PERFORMANT LUBE™ WALKING BELT

Your treadmill features a walking belt coated with PERFORMANT LUBE™, a high-performance lubricant. **IMPORTANT:** Never apply silicone spray or other substances to the walking belt or the walking platform. Such substances will deteriorate the walking belt and cause excessive wear.

HOW TO PLUG IN THE POWER CORD

⚠ DANGER: Improper connection of the equipment-grounding conductor can result in an increased risk of electric shock. Check with a qualified electrician or serviceman if you are in doubt as to whether the product is properly grounded. Do not modify the plug provided with the product—if it will not fit the outlet, have a proper outlet installed by a qualified electrician.

Your treadmill, like any other type of sophisticated electronic equipment, can be seriously damaged by sudden voltage changes in your home's power. Voltage surges, spikes, and noise interference can result from weather conditions or from other appliances being turned on or off. **To decrease the possibility of your treadmill being damaged, always use a surge suppressor with your treadmill (see drawing 1 at the right).** To purchase a surge suppressor, see your local REEBOK dealer or call 1-877-994-4999 and order part number 146148.

Use only a single-outlet surge suppressor that is UL 1449 listed as a transient voltage surge suppressor (TVSS). The surge suppressor must have a UL suppressed voltage rating of 400 volts or less and a minimum surge dissipation of 450 joules. The surge suppressor must be electrically rated for 120 volts AC and 15 amps. There must be a monitoring light on the surge suppressor to indicate whether it is functioning properly. Failure to use a properly functioning surge suppressor could result in damage to the control system of the treadmill. If the control system is damaged, the walking belt may change speed or stop unexpectedly, which may result in a fall and serious injury.

This product must be grounded. If it should malfunction or break down, grounding provides a path of least resistance for electric current to reduce the risk of electric shock. This product is equipped with a cord having

an equipment-grounding conductor and a grounding plug. **Plug the power cord into a surge suppressor, and plug the surge suppressor into an appropriate outlet that is properly installed and grounded in accordance with all local codes and ordinances. Important: The treadmill is not compatible with GFCI-equipped outlets.**

This product is for use on a nominal 120-volt circuit, and has a grounding plug that looks like the plug illustrated in drawing 1 below. A temporary adapter that looks like the adapter illustrated in drawing 2 may be used to connect the surge suppressor to a 2-pole receptacle as shown in drawing 2 if a properly grounded outlet is not available.

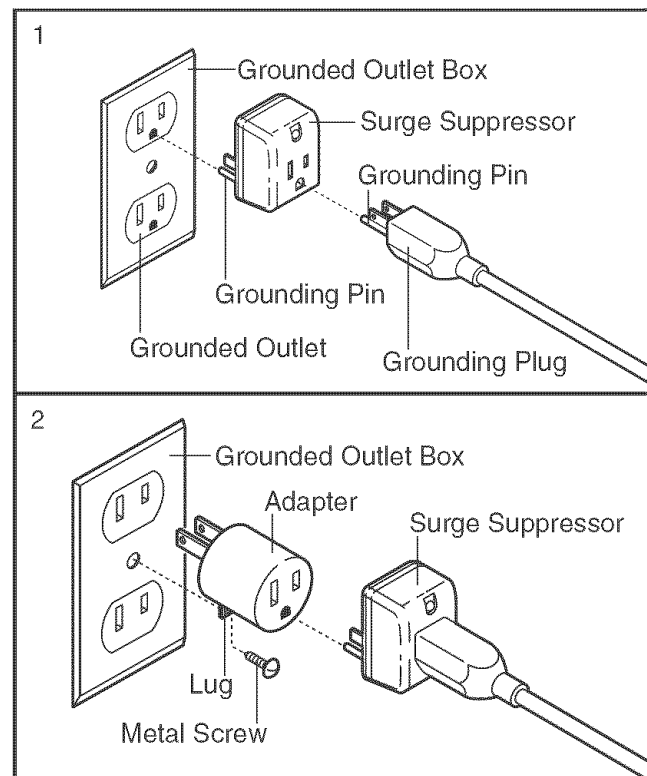

The temporary adapter should be used only until a properly grounded outlet (drawing 1) can be installed by a qualified electrician.

The green-colored rigid ear, lug, or the like extending from the adapter must be connected to a permanent ground such as a properly grounded outlet box cover. Whenever the adapter is used it must be held in place by a metal screw. **Some 2-pole receptacle outlet box covers are not grounded. Contact a qualified electrician to determine if the outlet box cover is grounded before using an adapter.**

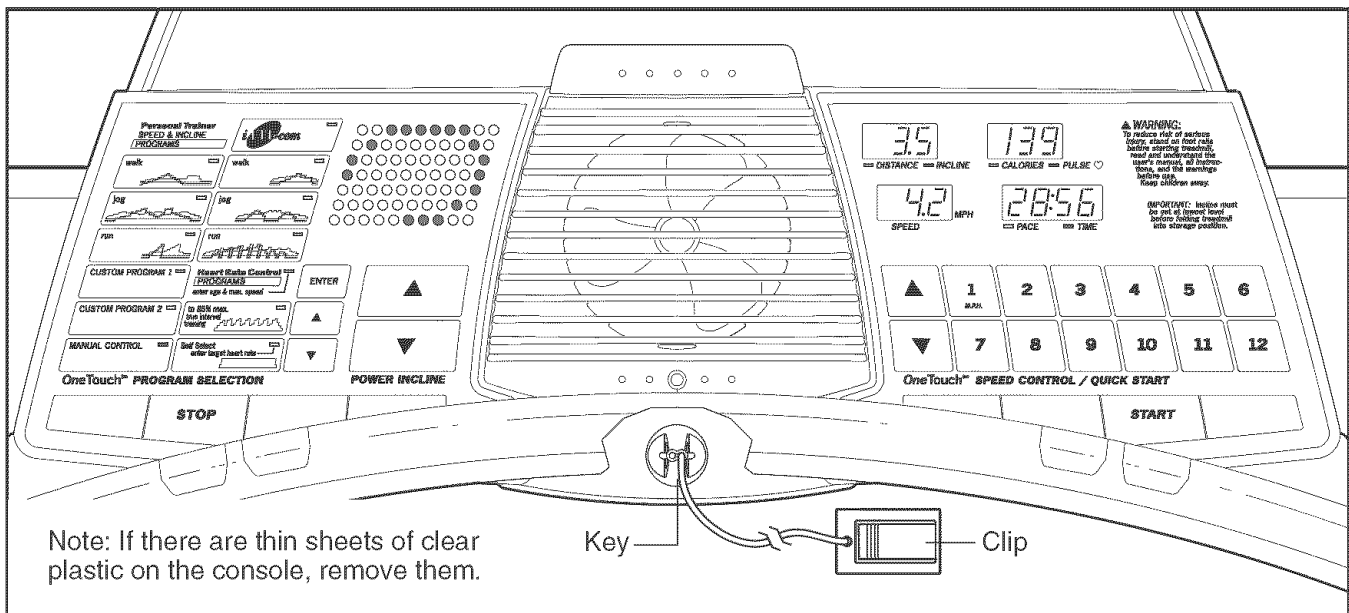

FEATURES OF THE CONSOLE

The treadmill console offers an impressive array of features designed to help you get the most from your workouts.

When the manual mode of the console is selected, the speed and incline of the treadmill can be changed with a touch of a button. As you exercise, the console will display instant exercise feedback. You can even measure your heart rate using the handgrip pulse sensor or the optional chest pulse sensor (see page 23).

The console also offers six personal trainer programs. Each program automatically controls the speed and incline of the treadmill as it guides you through an effective workout. Two heart rate programs are also offered. Each program adjusts the speed and incline of the treadmill to keep your heart rate near a target heart rate while you exercise. You can even create custom programs and save them in memory for future workouts.

The console also features new iFIT.com interactive technology. Having iFIT.com technology is like having a personal trainer in your home. Using the included audio

cable, you can connect the treadmill to your home stereo, portable stereo, computer, or VCR and play special iFIT.com CD and video programs (iFIT.com CDs and videocassettes are available separately). iFIT.com CD and video programs automatically control the speed and incline of the treadmill as a personal trainer coaches you through every step of your workout. High-energy music provides added motivation. **To purchase iFIT.com CDs or videocassettes, call toll-free 1-877-994-4999.**

With the treadmill connected to your computer, you can also go to our Web site at www.iFIT.com and access programs directly from the internet. Additional options are soon to be available. **See www.iFIT.com for more information.**

To use the manual mode of the console, follow the steps beginning on page 10. To use a personal trainer program, see page 12. To use a heart rate program, see page 14. To create and use a custom program, see pages 16 and 17. To use an iFIT.com CD or video program, see page 20. To use an iFIT.com program directly from our Web site, see page 22.

HOW TO TURN ON THE POWER

1 Plug in the power cord (see page 8).

2 Locate the reset/off circuit breaker on the treadmill near the power cord. Move the circuit breaker to the reset position.

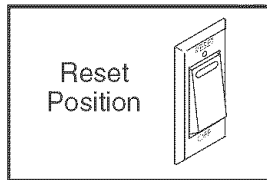

3 Stand on the foot rails of the treadmill. Find the clip attached to the key (see the drawing on page 9) and slide the clip onto the waistband of your clothes. Next, route the cord attached to the clip **under the handgrip pulse sensor**, and insert the key into the console. After a moment, the displays and various indicators will light. **Test the clip by carefully taking a few steps backward until the key is pulled from the console. If the key is not pulled from the console, adjust the position of the clip.**

HOW TO USE THE MANUAL MODE

1 Insert the key into the console.
See HOW TO TURN ON THE POWER above.

2 Select the manual mode.

When the key is inserted, the manual mode will be selected and the indicator on the Manual Control button will light. If you have selected a program, reselect the manual mode by pressing the Manual Control button.

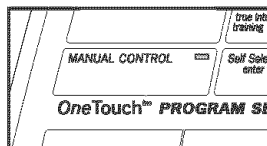

3 Start the walking belt.

To start the walking belt, press the Start button, the Speed increase button, or one of the twelve Quick Start buttons.

If the Start button or the Speed increase button is pressed, the walking belt will begin to move at 1 mph. As you exercise, change the speed of the walking belt as desired by pressing the Speed increase and decrease buttons. Each time a button is pressed, the speed setting will change by 0.1 mph; if a button is held down, the speed setting will change in increments of 0.5 mph.

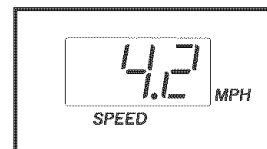

If one of the Quick Start buttons is pressed, the walking belt will gradually increase in speed until it reaches the selected speed setting. **Note: The console can display speed and distance in either miles or kilometres. For simplicity, all instructions in this section refer to miles.**

To stop the walking belt, press the Stop button. The time will begin to flash in the Pace/Time display. To restart the walking belt, press the Start button, the Speed increase button, or one of the twelve Quick Start buttons.

Note: The first time the treadmill is used, observe the alignment of the walking belt, and align the walking belt if necessary (see page 27).

4 Change the incline of the treadmill as desired.

To change the incline of the treadmill, press the Incline increase and decrease buttons. Each time a button is pressed, the incline will change by 0.5%.

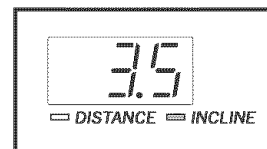

5 Follow your progress with the matrix and the displays.

The matrix—When the manual mode or the iFIT.com mode is selected, the matrix will display a 1/4-mile track.

As you exercise, the indicators around the track will light in succession until the entire track is lit. The track will then darken and the indicators will again begin to light in succession.

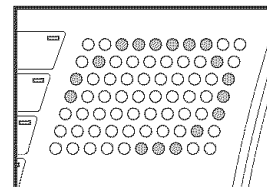

Distance/Incline display

This display shows the distance that you have walked or run and the incline level of the treadmill. The display will change from one number to the other every few seconds. Note: Each time the incline changes, the display will show the incline setting for several seconds.

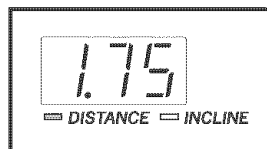

Calories/Pulse display

This display shows the approximate number of calories you have burned. The display will also show your heart rate when you use the handgrip pulse sensor or the optional chest pulse sensor. The display will change from one number to the other every few seconds.



Speed display

This display shows the speed of the walking belt.

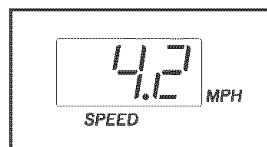

Note: The console can display speed and distance in either miles or kilometres. To find which unit of measurement is selected, hold down the Stop button while inserting the key into the console. An "E" for English miles or an "M" for metric kilometres will appear in the Speed display. Press the Speed increase button to change the unit of measurement. When the desired unit of measurement is selected, remove the key.

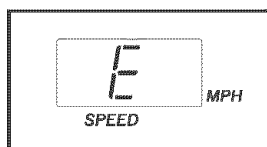

Pace/Time display

When the manual mode or the iFIT.com mode is selected, this display will show your current pace, in minutes per mile, and the elapsed time. The display will change from one number to the other every few seconds. When a program is selected (except for the Self Select heart rate program), the display will show the elapsed time and the time remaining in the program.



To reset the displays, press the Stop button, remove the key, and then reinsert the key.

6 Measure your heart rate if desired.

To use the handgrip pulse sensor, first make sure that your hands are clean. Next, **stand on the foot rails** and hold the handgrip pulse

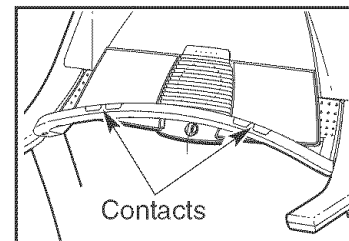

sensor, with your palms on the metal contacts. **Avoid moving your hands.** When your pulse is detected, two dashes (--) will appear in the Calories/Pulse display, and then your heart rate will be shown. **For the most accurate heart rate reading, continue to hold the contacts for about 15 seconds.**

7 Turn on the fan if desired.

To turn on the fan, press the button below the fan. To turn on the fan at high speed, press the button a second time. To turn off the fan, press the button a third time. Note: A few minutes after the walking belt is stopped, the fan will automatically turn off.

8 When you are finished exercising, remove the key from the console.

Step onto the foot rails, press the Stop button, and **adjust the incline of the treadmill to the lowest setting. The incline must be at the lowest setting when the treadmill is folded to the storage position or the treadmill will be damaged.** Next, remove the key from the console and put it in a secure place. **Note: If the displays and various indicators on the console remain lit after the key is removed, the console is in the "demo" mode. See page 23 and turn off the demo mode.**

When you are finished using the treadmill, move the reset/off circuit breaker to the off position and unplug the power cord.

HOW TO USE PERSONAL TRAINER PROGRAMS

1 Insert the key into the console.

See HOW TO TURN ON THE POWER on page 10.

2 Select one of the personal trainer programs.

To select a personal trainer program, press one of the Walk, Jog, or Run buttons. The indicator on the button that you press will light.

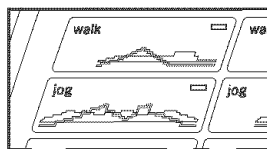

When a personal trainer program is selected, the Speed display will flash the maximum speed setting of the program for a few seconds, and the Distance/Incline display will flash the maximum incline setting. The Pace/Time display will show how long the program will last.

The matrix will show the first seven speed settings of the program. Note: The diagrams on the Walk, Jog, and Run buttons show how the speed and incline of

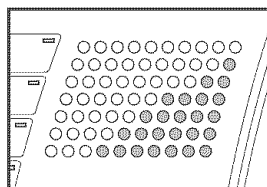

the treadmill will change during the personal trainer programs. For example, the diagram on the right Walk button shows that the speed and incline will gradually increase during the first half of the program and then gradually decrease during the last half.

3 Press the Start button or the Speed increase button to start the program.

A moment after the button is pressed, the treadmill will automatically adjust to the first speed and incline settings of the program. Hold the handrails and begin walking.

Each program is divided into several time segments of different lengths. One speed setting and one incline setting are programmed for each segment. Note: The same speed setting and/or incline setting may be programmed for two or more consecutive segments.

The speed setting for the first segment is shown in the flashing Current Segment column of the matrix. (The incline settings are not shown in the matrix.) The speed settings for the next seven segments are shown in the seven columns to the right.

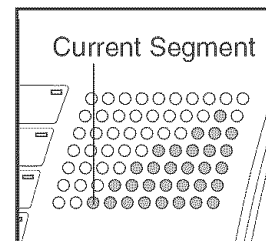

When only three seconds remain in the first segment of the program, both the Current Segment column and the column to the right will flash and a series of tones will sound. If the speed and/or incline of the treadmill is about to change, the Speed display and/or the Distance/Incline display will flash to alert you. When the first segment ends, *all speed settings will move one column to the left.* The speed setting for the second segment will then be shown in the flashing Current Segment column and the treadmill will automatically adjust to the speed and incline settings for the second segment. Note: If all of the indicators in the Current Segment column are lit after the speed settings have moved to the left, *the speed settings may move downward* so that only the highest indicators appear in the matrix. If some of the indicators in the Current Segment column are not lit when the speed settings move to the left again, the speed settings will move back up.

The program will continue in this way until the speed setting for the last segment is shown in the Current Segment column and the last segment ends. The walking belt will then slow to a stop.

If the speed or incline setting is too high or too low at any time during the program, you can manually override the setting by pressing the Speed or Incline buttons. Every few times a Speed button is pressed, an additional indicator will light or darken in the Current Segment column. (If any of the columns to the right of the Current Segment column have the same number of lit indicators as the Current Segment column, an additional indicator may light or darken in those columns as well.)

Note: When the next segment of the program begins, the treadmill will automatically adjust to the speed and incline settings for the next segment.

To stop the program at any time, press the Stop button. The time will begin to flash in the Pace/Time display. To restart the program, press the Start button or the Speed increase button. The walking belt will begin to move at 1 mph. When the next segment of the program begins, the treadmill will automatically adjust to the speed and incline settings for the next segment.

4 Follow your progress with the displays.

See step 5 on page 10.

5 Measure your heart rate if desired.

See step 6 on page 11.

6 Turn on the fan if desired.

See step 7 on page 11.

7 When you are finished exercising, remove the key from the console.

When the program has ended, **make sure that the incline of the treadmill is at the lowest setting.** Next, remove the key from the console and put it in a secure place. **Note: If the displays and various indicators on the console remain lit after the key is removed, the console is in the “demo” mode. See page 23 and turn off the demo mode.**

When you are finished using the treadmill, move the reset/off circuit breaker to the off position and unplug the power cord.

HOW TO USE HEART RATE PROGRAMS

CAUTION: If you have heart problems, or if you are over 60 years of age and have been inactive, do not use the heart rate programs. If you are taking medication regularly, consult your physician to find whether the medication will affect your exercise heart rate.

1 Put on the optional chest pulse sensor.

You must wear the optional chest pulse sensor (see page 23) to use a heart rate program.

2 Insert the key into the console.

See HOW TO TURN ON THE POWER on page 10.

3 Select a heart rate program.

To select a heart rate program, press the 85% Max or Self Select button. The indicator on the button that you press will light.

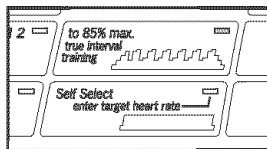

During the 85% Max program, your heart rate will reach approximately 85% of your *estimated maximum heart rate*; during the Self Select program, your heart rate will remain near a level that you select. Note: Your estimated maximum heart rate is determined by subtracting your age from 220. For example, if you are 30 years old, your estimated maximum heart rate is 190 beats per minute ($220 - 30 = 190$).

During heart rate programs, the matrix will show a moving graphic that represents your heart rate. Each time a heartbeat is detected, a peak will appear.

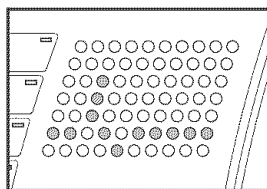

4 Enter your age.

When a heart rate program is selected, the word "AGE" and the current age setting will flash in the Calories/Pulse display. If you have already entered your age, simply press the Enter button. If you have not entered your age, press the increase and decrease buttons below the Enter button to enter your age. Then, press the Enter button.



5 Enter a maximum speed.

After you have entered your age, the letters "SPd" and the maximum speed setting of the program will flash in the Speed display. If desired, press the increase and decrease buttons below the Enter button to adjust the maximum speed setting. When the desired setting is shown, press the Enter button.

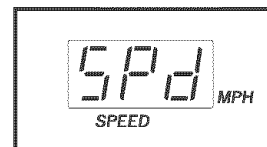

If the 85% Max program is selected, go to step 7. If the Self Select program is selected, go to step 6.

6 Enter a target heart rate.

The letters "PLS" and the target heart rate setting for the program will flash in the Calories/Pulse display. If desired, press the increase and decrease buttons below the Enter button to adjust the target heart rate setting. When the desired setting is shown, press the Enter button.

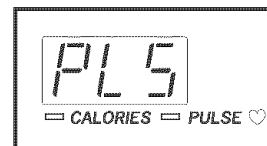

7 Press the Start button or the Speed increase button to start the program.

A moment after the button is pressed, the treadmill will automatically adjust to the first speed and incline settings of the program. Hold the handrails and begin walking.

Each heart rate program is divided into several time segments of different lengths. One target heart rate is programmed for each segment. Note: If the Self Select program is selected, the same target heart rate is programmed for all segments.

During each segment, the console will regularly compare your heart rate to the current target heart rate. If your heart rate is too far below or above the target heart rate, a tone will sound and the speed of the treadmill will automatically increase or decrease to bring your heart rate closer to the target heart rate. If the speed reaches the maximum speed setting of the program (see step 5 on page 14) and your heart rate is still too far below the current target heart rate, the incline of the treadmill will also increase to bring your heart rate closer to the target heart rate.

During the last three seconds of each segment, a series of tones will sound and the Speed display and the Distance/Incline display will flash.

The program will continue until the last segment ends. The walking belt will then slow to a stop.

If the speed or incline setting is too high or too low at any time during the program, you can adjust the setting with the Speed or Incline buttons. However, each time the console compares your heart rate to

the current target heart rate, the speed and/or incline of the treadmill may automatically change to bring your heart rate closer to the target heart rate.

If your pulse is not detected during the program, the letters "PLS" will flash in the Calories/Pulse display and the speed and incline of the treadmill may automatically decrease until your pulse is detected. If this occurs, see the instructions included with the optional chest pulse sensor.

To stop the program at any time, press the Stop button. Heart rate programs cannot be stopped temporarily and then restarted. To use a heart rate program again, reselect the program and start it at the beginning.

8 Follow your progress with the displays.

See step 5 on page 10.

9 Turn on the fan if desired.

See step 7 on page 11.

10 When you are finished exercising, remove the key from the console.

See step 7 on page 13.

HOW TO CREATE CUSTOM PROGRAMS

1 Insert the key into the console.

See HOW TO TURN ON THE POWER on page 10.

2 Select one of the custom programs.

To select a custom program, press the Custom Program 1 button or the Custom Program 2 button. The indicator on the button that you press will light.

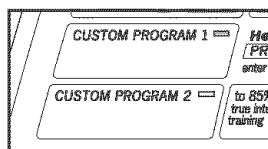

3 Press the Start button or the Speed increase button and program the desired speed and incline settings.

A moment after the button is pressed, the walking belt will begin to move. Hold the handrails and begin walking.

See the matrix. Each custom program is divided into one-minute segments. One speed setting and one incline setting can be programmed for each segment. The speed setting for the first segment will be shown in the flashing Current Segment column of the matrix. (The incline settings are not shown

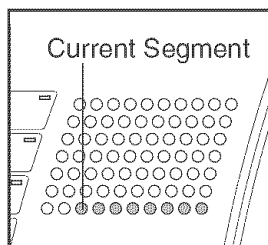

in the matrix.) To program a speed setting and an incline setting for the first segment, simply adjust the speed and incline of the treadmill as desired by pressing the Speed and Incline buttons. Every few times one of the Speed buttons is pressed, an additional indicator will light or darken in the Current Segment column.

During the last three seconds of the first segment, both the Current Segment column and the column to the right will flash, a series of tones will sound, and the Speed display and the Distance/Incline display will flash. When the first segment ends, the current speed setting and the current incline setting will be saved in memory, and *all speed settings in the matrix will move one column to the left*. The speed setting for the second segment will then be shown in the flashing Current Segment column. Program a speed setting and an incline setting for the second segment as described above.

Continue programming speed and incline settings for as many segments as desired; custom programs can have up to forty segments. When you are finished with your workout, press the Stop button twice. The speed and incline settings that you have programmed and the number of segments that you have programmed will then be saved in memory.

4 When the program is finished, remove the key.

See step 7 on page 13.

HOW TO USE CUSTOM PROGRAMS

1 Insert the key into the console.

See HOW TO TURN ON THE POWER on page 10.

2 Select one of the custom programs.

To select a custom program, press the Custom Program 1 button or the Custom Program 2 button. The indicator on the button that you press will light. When a custom program is selected, the Speed display will flash the maximum speed setting of the program for a few seconds, and the Distance/Incline display will flash the maximum incline setting. The Pace/Time display will show how long the program will last.

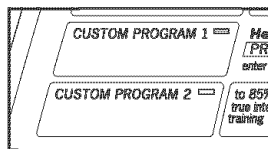

The matrix will show the first seven speed settings of the program.

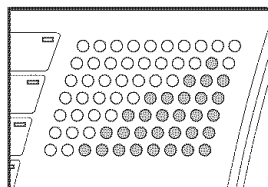

3 Press the Start button or the Speed increase button to start the program.

A moment after the button is pressed, the treadmill will automatically adjust to the first speed and incline settings that you programmed previously. Hold the handrails and begin walking.

Each custom program is divided into several one-minute segments. One speed setting and one incline setting are programmed for each segment. The speed setting for the first segment is shown in the flashing Current Segment column of the matrix. (The incline settings are not shown in the matrix.) The speed settings for the next seven segments are shown in the columns to the right.

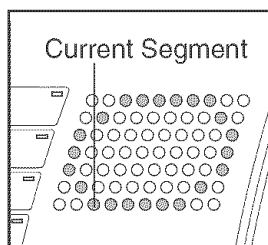

When only three seconds remain in the first segment of the program, both the Current Segment

column and the column to the right will flash, a series of tones will sound, the Speed display and the Distance/Incline display will flash, and *all speed settings will move one column to the left*. The speed setting for the second segment will then be shown in the flashing Current Segment column and the treadmill will automatically adjust to the second speed and incline settings that you programmed previously.

The program will continue until the speed setting for the last segment is shown in the Current Segment column and the last segment ends. The walking belt will then slow to a stop.

If desired, you can change the program while using it. **To change the speed or incline setting for the current segment**, simply press the Speed or Incline buttons. When the current segment ends, the new setting will be saved in memory. **To increase the length of the program**, first wait until the program ends. Then, press the Start button and program speed and incline settings for as many additional segments as desired. When you have added as many segments as desired, press the Stop button twice. **To decrease the length of the program**, press the Stop button twice at any time before the program ends.

To stop the program at any time, press the Stop button. The time will begin to flash in the Pace/Time display. To restart the program, press the Start button or the Speed increase button. The walking belt will begin to move at 1 mph. When the next segment of the program begins, the treadmill will automatically adjust to the speed and incline settings for the next segment.

4 Follow your progress with the displays.

See step 5 on page 10.

5 Measure your heart rate if desired.

See step 6 on page 11.

6 Turn on the fan if desired.

See step 7 on page 11.

7 When you are finished exercising, remove the key from the console.

See step 7 on page 13.

HOW TO CONNECT THE TREADMILL TO YOUR CD PLAYER, VCR, OR COMPUTER

To use iFIT.com CDs, the treadmill must be connected to your portable CD player, portable stereo, home stereo, or computer with CD player. See pages 18 and 19 for connecting instructions. To use iFIT.com videocassettes, the treadmill must be connected to your VCR. See page 20 for connecting instructions. To use iFIT.com programs directly from our Web site, the treadmill must be connected to your home computer. See page 19 for connecting instructions.

HOW TO CONNECT YOUR PORTABLE CD PLAYER

Note: If your CD player has separate LINE OUT and PHONES jacks, see instruction A below. If your CD player has only one jack, see instruction B.

- A. Plug one end of the audio cable into the jack on the front of the treadmill near the power cord. Plug the other end of the cable into the LINE OUT jack on your CD player. Plug your headphones into the PHONES jack.

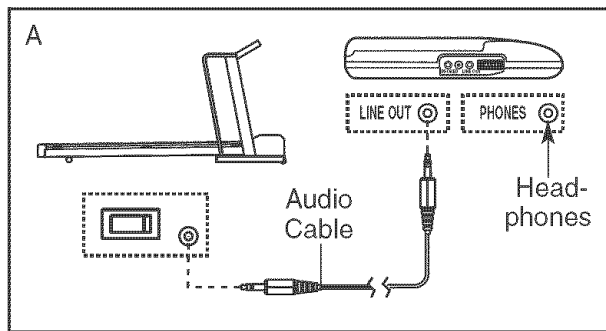

- B. Plug one end of the audio cable into the jack on the front of the treadmill near the power cord. Plug the other end of the cable into a 3.5mm Y-adapter (available at electronics stores). Plug the Y-adapter into the PHONES jack on your CD player. Plug your headphones into the other side of the Y-adapter.

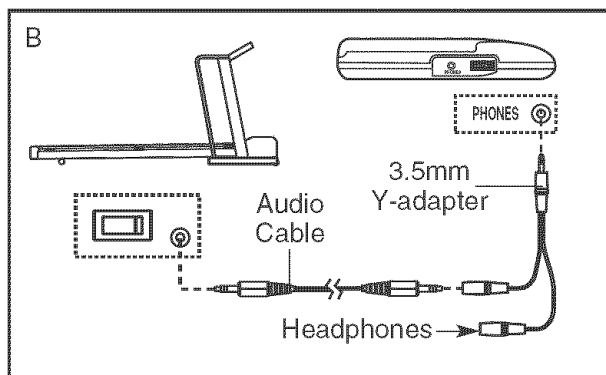

HOW TO CONNECT YOUR PORTABLE STEREO

Note: If your stereo has an RCA-type AUDIO OUT jack, see instruction A below. If your stereo has a 3.5mm LINE OUT jack, see instruction B. If your stereo has only a PHONES jack, see instruction C.

- A. Plug one end of the audio cable into the jack on the front of the treadmill near the power cord. Plug the other end of the cable into the included adapter. Plug the adapter into an AUDIO OUT jack on your stereo.

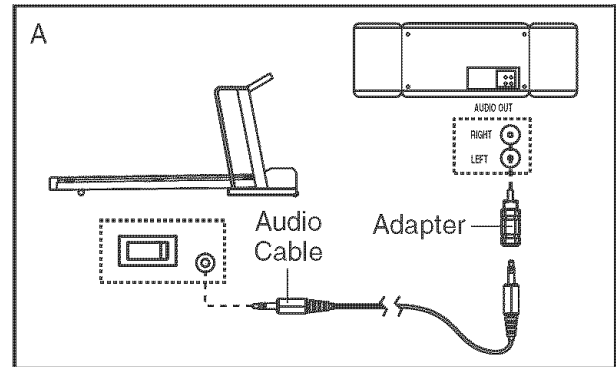

- B. Plug one end of the audio cable into the jack on the front of the treadmill near the power cord. Plug the other end of the cable into the LINE OUT jack on your stereo.

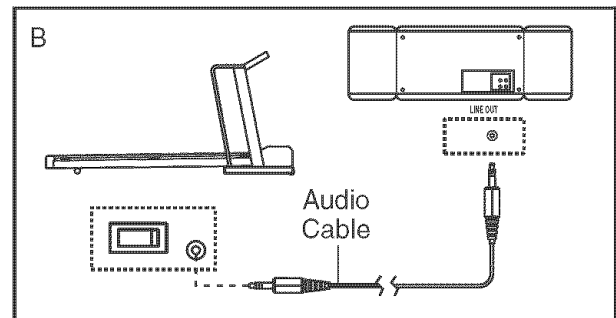

- C. Plug one end of the audio cable into the jack on the front of the treadmill near the power cord. Plug the other end of the cable into a 3.5mm Y-adapter (available at electronics stores). Plug the Y-adapter into the PHONES jack on your stereo. Plug your headphones into the other side of the Y-adapter.

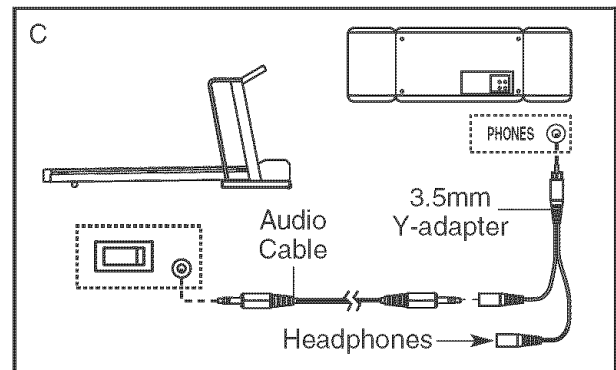

HOW TO CONNECT YOUR HOME STEREO

Note: If your stereo has an unused **LINE OUT** jack, see instruction **A** below. If the **LINE OUT** jack is being used, see instruction **B**.

- A. Plug one end of the audio cable into the jack on the front of the treadmill near the power cord. Plug the other end of the cable into the included adapter. Plug the adapter into the **LINE OUT** jack on your stereo.

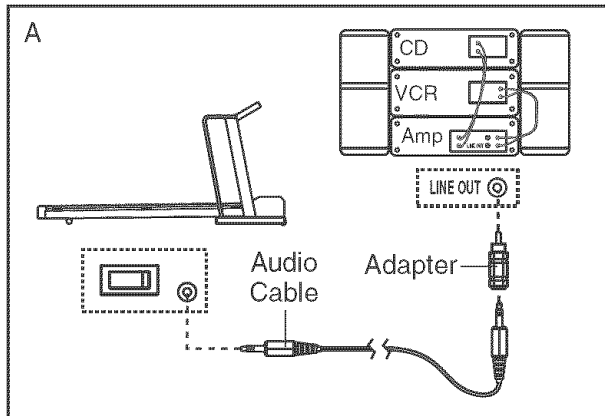

- B. Plug one end of the audio cable into the jack on the front of the treadmill near the power cord. Plug the other end of the cable into the included adapter. Plug the adapter into an **RCA Y-adapter** (available at electronics stores). Next, remove the wire that is currently plugged into the **LINE OUT** jack on your stereo and plug the wire into the unused side of the **Y-adapter**. Plug the **Y-adapter** into the **LINE OUT** jack on your stereo.

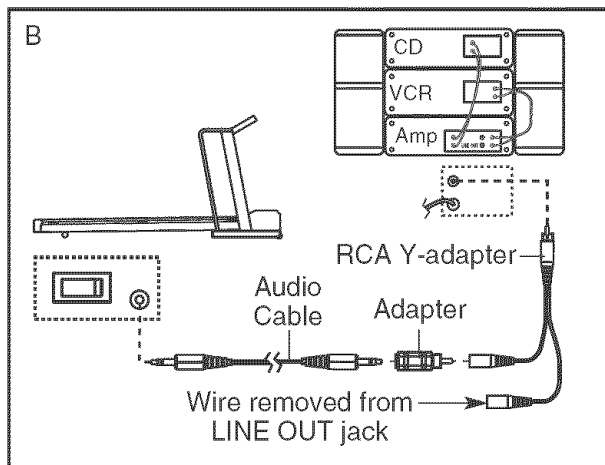

HOW TO CONNECT YOUR COMPUTER

Note: If your computer has a **3.5mm LINE OUT** jack, see instruction **A**. If your computer has only a **PHONES** jack, see instruction **B**.

- A. Plug one end of the audio cable into the jack on the front of the treadmill near the power cord. Plug the other end of the cable into the **LINE OUT** jack on your computer.

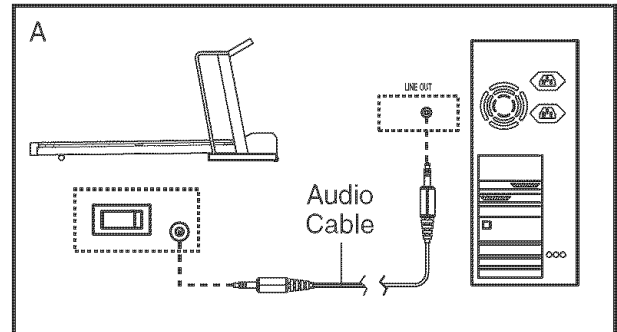

- B. Plug one end of the audio cable into the jack on the front of the treadmill near the power cord. Plug the other end of the cable into a **3.5mm Y-adapter** (available at electronics stores). Plug the **Y-adapter** into the **PHONES** jack on your computer. Plug your headphones or speakers into the other side of the **Y-adapter**.

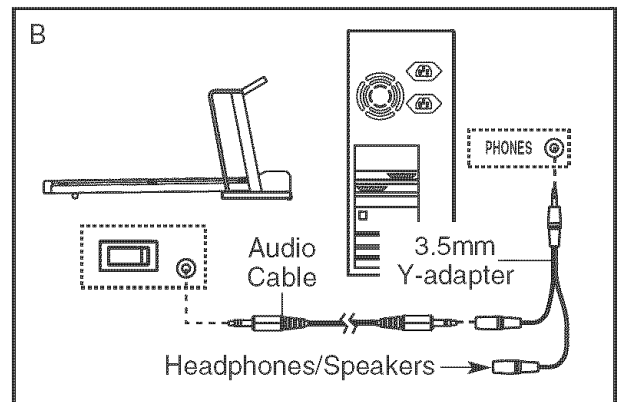

HOW TO CONNECT YOUR VCR

Note: If your VCR has an unused AUDIO OUT jack, see instruction A below. If the AUDIO OUT jack is being used, see instruction B. If you have a TV with a built-in VCR, see instruction B. If your VCR is connected to your home stereo, see **HOW TO CONNECT YOUR HOME STEREO** on page 19.

- A. Plug one end of the audio cable into the jack on the front of the treadmill near the power cord. Plug the other end of the cable into the included adapter. Plug the adapter into the AUDIO OUT jack on your VCR.

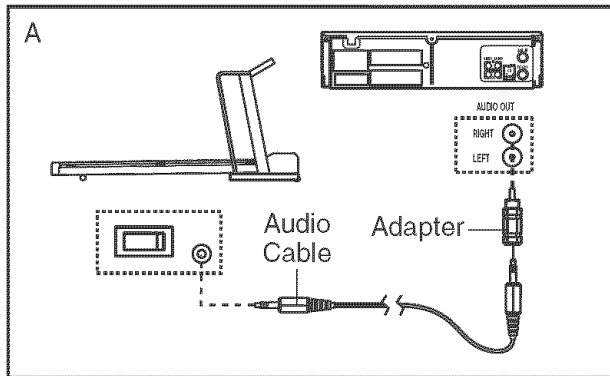

- B. Plug one end of the audio cable into the jack on the front of the treadmill near the power cord. Plug the other end of the cable into the included adapter. Plug the adapter into an RCA Y-adapter (available at electronics stores). Next, remove the wire that is currently plugged into the AUDIO OUT jack on your VCR and plug the wire into the unused side of the Y-adapter. Plug the Y-adapter into the AUDIO OUT jack on your VCR.

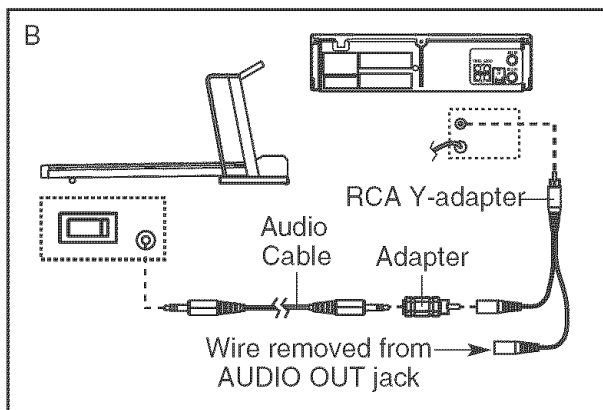

HOW TO USE iFIT.COM CD AND VIDEO PROGRAMS

To use iFIT.com CDs or videocassettes, the treadmill must be connected to your portable CD player, portable stereo, home stereo, computer with CD player, or VCR. See **HOW TO CONNECT THE TREADMILL TO YOUR CD PLAYER, VCR, OR COMPUTER** on page 18. **Note:** To purchase iFIT.com CDs or iFIT.com videocassettes, call toll-free 1-877-994-4999.

Follow the steps below to use an iFIT.com CD or video program.

- 1** Insert the key into the console.

See **HOW TO TURN ON THE POWER** on page 10.

- 2** Select the iFIT.com mode.

To use an iFIT.com CD or video program, press the iFIT.com button. The indicator on the button will light.

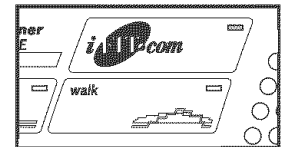

- 3** Insert the iFIT.com CD or videocassette.

If you are using an iFIT.com CD, insert the CD into your CD player. If you are using an iFIT.com videocassette, insert the videocassette into your VCR.

- 4** Press the PLAY button on your CD player or VCR.

A moment after the button is pressed, your personal trainer will begin guiding you through your workout. Simply follow your personal trainer's instructions. **Note:** If the time is flashing in the Pace/Time display, press the Start button or the Speed increase button on the console. The treadmill will not respond to a CD or video program while the Pace/Time display is flashing.

During the CD or video program, an electronic "chirping" sound will alert you when the speed and/or incline of the treadmill is about to change. **CAUTION: Always listen for the "chirp" and be prepared for speed and/or incline changes. In some instances, the speed and/or incline may change before the personal trainer describes the change.**

If the speed or incline settings are too high or too low, you can manually override the settings by pressing the Speed or Incline buttons on the console. However, **when the next “chirp” is heard, the speed and/or incline will change to the next settings of the CD or video program.**

To stop the walking belt at any time, press the Stop button on the console. The time will begin to flash in the Pace/Time display. To restart the program, press the Start button or the Speed increase button. After a moment, the walking belt will begin to move at 1 mph. **When the next “chirp” is heard, the speed and incline will change to the next settings of the CD or video program.**

When the CD or video program is completed, the walking belt will stop and the time will begin to flash in the Pace/Time display. Note: To use another CD or video program, press the Stop button or remove the key and go to step 1 on page 20.

Note: If the speed or incline of the treadmill does not change when a “chirp” is heard:

- **Make sure that the indicator on the iFIT.com button is lit and that the time is not flashing in the Pace/Time display. If the Pace/Time display is flashing, press the Start button or the Speed increase button on the console.**
- **Adjust the volume of your CD player or VCR. If the volume is too high or too low, the console may not detect the program signals.**

- **Make sure that the audio cable is properly connected, that it is fully plugged in, and that it is not wrapped around a power cord.**
- **If you are using your portable CD player and the CD skips, set the CD player on the floor or another flat surface instead of on the console.**

5 Follow your progress with the LED track and the displays.

See step 5 on page 10.

6 Measure your heart rate if desired.

See step 6 on page 11.

7 Turn on the fan if desired.

See step 7 on page 11.

8 When you are finished exercising, remove the key from the console.

See step 7 on page 13.

CAUTION: Always remove iFIT.com CDs and videocassettes from your CD player or VCR when you are finished using them.

HOW TO USE PROGRAMS DIRECTLY FROM OUR WEB SITE

Our Web site at www.iFIT.com allows you to access programs directly from the internet. Additional options are soon to be available. See www.iFIT.com for more information.

To use programs from our Web site, the treadmill must be connected to your home computer. See HOW TO CONNECT YOUR COMPUTER on page 19. In addition, you must have an internet connection and an internet service provider. A list of specific system requirements is found on our Web site.

Follow the steps below to use a program from our Web site.

1 Insert the key into the console.

See HOW TO TURN ON THE POWER on page 10.

2 Select the iFIT.com mode.

To use an iFIT.com CD or video program, press the iFIT.com button. The indicator on the button will light.

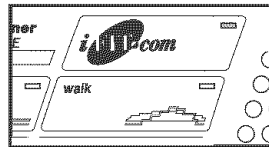

3 Go to your computer and start an internet connection.

4 Start your web browser, if necessary, and go to our Web site at www.iFIT.com.

5 Follow the desired links on our Web site to select a program.

Read and follow the on-line instructions for using a program.

6 Follow the on-line instructions to start the program.

When you start the program, an on-screen countdown will begin.

7 Return to the treadmill and stand on the foot rails. Find the clip attached to the key and slide the clip onto the waistband of your clothes.

When the on-screen countdown ends, the program will begin and the walking belt will begin to move. Hold the handrails, step onto the walking belt, and begin walking. During the program, an electronic “chirping” sound will alert you when the speed and/or incline of the treadmill is about to change. **CAUTION: Always listen for the “chirp” and be prepared for speed and/or incline changes.**

If the speed or incline settings are too high or too low, you can manually override the settings by pressing the Speed or Incline buttons on the console. **However, when the next “chirp” is heard, the speed and/or incline will change to the next settings of the program.**

To stop the walking belt at any time, press the Stop button on the console. The time will begin to flash in the Pace/Time display. To restart the program, press the Start button or the Speed increase button. After a moment, the walking belt will begin to move at 1 mph. **When the next “chirp” is heard, the speed and incline will change to the next settings of the program.**

When the program ends, the walking belt will stop and the time will begin to flash in the Pace/Time display. Note: To use another program, press the Stop button and go to step 5.

Note: If the speed or incline of the treadmill does not change when a “chirp” is heard, make sure that the indicator on the iFIT.com button is lit and that the Pace/Time display is not flashing. In addition, make sure that the audio cable is properly connected, that it is fully plugged in, and that it is not wrapped around a power cord.

8 Follow your progress with the LED track and the displays.

See step 5 on page 10.

9 When you are finished exercising, remove the key from the console.

See step 7 on page 13.

THE INFORMATION MODE/DEMO MODE

The console features an information mode that keeps track of the total number of hours that the treadmill has been operated and the total number of miles or kilometres that the walking belt has moved. The information mode also allows you to switch the console from miles per hour to kilometres per hour. In addition, the information mode allows you to turn on and turn off the demo mode.

To select the information mode, hold down the Stop button while inserting the key into the console. When the information mode is selected, the following information will be shown:

The Distance/Incline display will show the total number of miles (or kilometres) that the walking belt has moved.



The Pace/Time display will show the total number of hours the treadmill has been used.

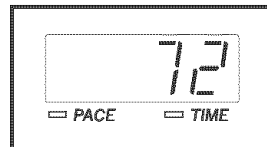

An "E" for English miles or an "M" for metric kilometres will appear in the Speed display. Press the Speed increase button to change the unit of measurement.

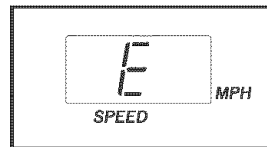

IMPORTANT: The Calories/Pulse display should be blank. If a "d" appears in the display, the console is in the "demo" mode. This mode is intended to be used only when a treadmill is displayed in a store. When the console is in the demo mode, the power cord can be plugged in, the key can be removed from the console, and the displays and indicators on the console will automatically light in a preset sequence, although the buttons on the console will not operate. **If a "d" appears in the Calories/Pulse display when the information mode is selected, press the Speed decrease button so the display is blank.**

To exit the information mode, remove the key.

HOW TO ADJUST THE CUSHIONING SYSTEM

The treadmill features a cushioning system that reduces the impact as you walk or run on the treadmill. To increase the firmness of the walking platform, turn the adjustment knob counterclockwise. To decrease the firmness, turn the knob clockwise. **Note: The faster you run on the treadmill, or the more you weigh, the firmer the walking platform should be.**

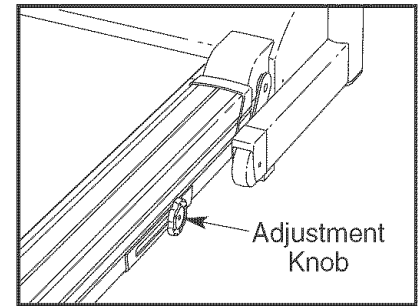

THE OPTIONAL CHEST PULSE SENSOR

An optional chest pulse sensor provides hands-free operation and allows you to use the console's heart rate programs. **To purchase the optional chest pulse sensor, call toll-free 1-877-994-4999.**

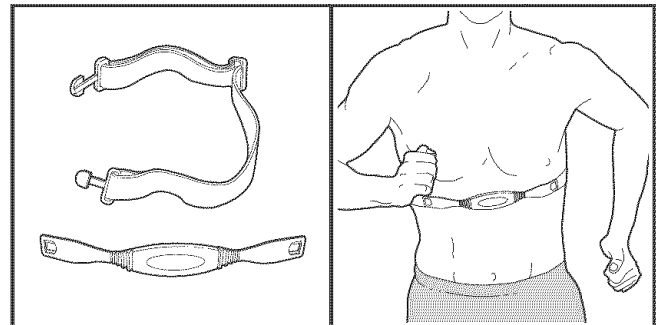

HOW TO FOLD AND MOVE THE TREADMILL

HOW TO FOLD THE TREADMILL FOR STORAGE

Before folding the treadmill, adjust the incline to the lowest position. If this is not done, the treadmill may be permanently damaged. Next, unplug the power cord.

CAUTION: You must be able to safely lift 45 pounds (20 kg) to raise, lower, or move the treadmill.

1. Hold the treadmill in the locations shown at the right. To decrease the possibility of injury, bend your legs and keep your back straight. As you raise the treadmill, make sure to lift with your legs rather than your back. Raise the treadmill about halfway to the vertical position.

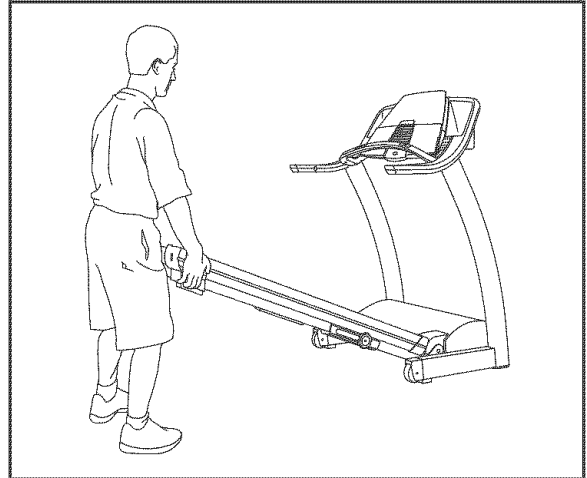

2. Hold the treadmill frame firmly with your left hand. Using your right hand, pull the latch knob to the right and hold it. Raise the treadmill until the pin on the latch knob is aligned with the hole in the left handgrip. Then, release the latch knob. Make sure that the latch knob is fully released so that the pin is fully inserted into the hole in the left handgrip.

To protect the floor or carpet from damage, place a mat under the treadmill. Keep the treadmill out of direct sunlight. Do not leave the treadmill in the storage position in temperatures above 85° Fahrenheit.

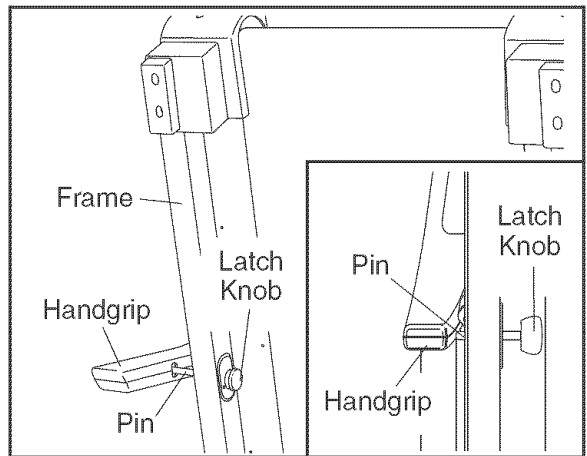

HOW TO MOVE THE TREADMILL

Before moving the treadmill, convert the treadmill to the storage position as described above. Make sure that the pin on the latch knob is fully inserted into the hole in the left handgrip.

1. Hold the handgrips and place one foot on the base.
2. Tilt the treadmill back until it rolls freely on the wheels. Carefully move the treadmill to the desired location. To reduce the risk of injury, use extreme caution while moving the treadmill. Do not attempt to move the treadmill over an uneven surface.
3. Place one foot on the wheel, and carefully lower the treadmill until the base is resting in the storage position.

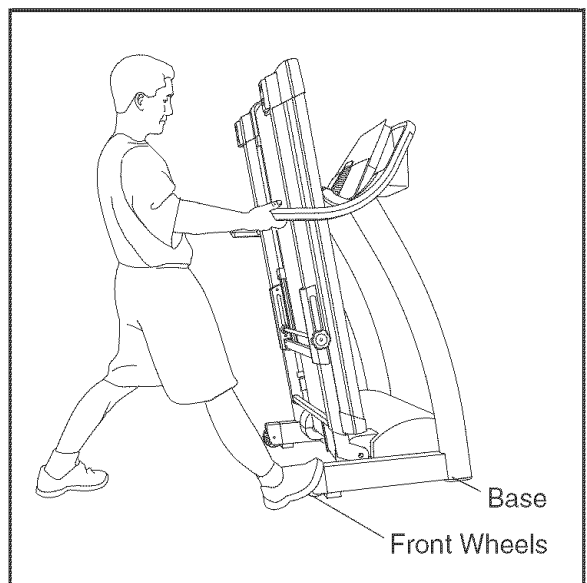

HOW TO LOWER THE TREADMILL FOR USE

1. Hold the treadmill frame firmly with your left hand. Pull the latch knob to the right. Pivot the treadmill down until the pin on the latch knob is below the handgrip. Slowly release the latch knob.

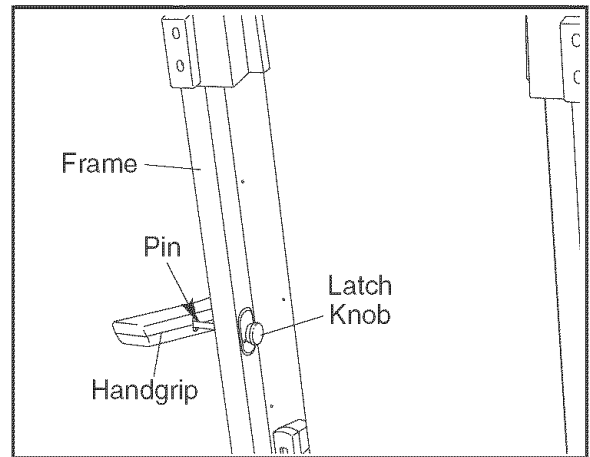

2. Hold the treadmill firmly with both hands, and lower the treadmill to the floor. **To decrease the possibility of injury, bend your legs and keep your back straight.**

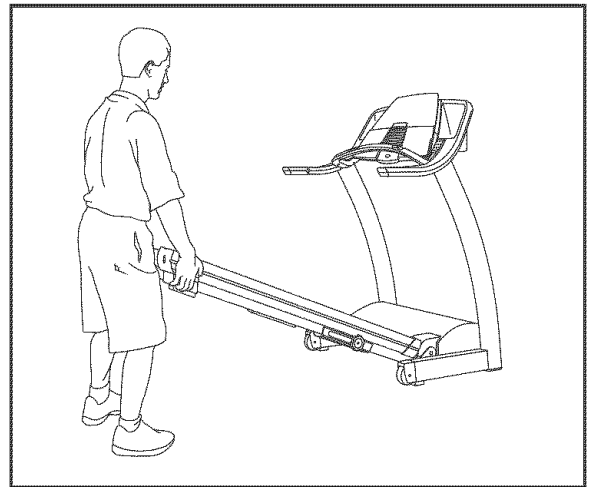

TROUBLESHOOTING

Most treadmill problems can be solved by following the instructions below. If further assistance is needed, please call our Customer Service Department toll-free at 1-877-994-4999, Monday through Friday, 6 a.m. until 6 p.m. Mountain Time (excluding holidays).

PROBLEM

SOLUTION

1. The power does not turn on

- Make sure that the power cord is plugged into a surge suppressor, and that the surge suppressor is plugged into a properly grounded outlet (see page 8). Use only a single-outlet surge suppressor that meets all of the specifications described on page 8. Important: The treadmill is not compatible with GFCI-equipped outlets.
- Make sure that the key is fully inserted into the console.
- Check the reset/off circuit breaker located on the frame near the power cord. If the switch protrudes as shown, the circuit breaker has tripped. To reset the circuit breaker, wait for five minutes and then press the switch back in.

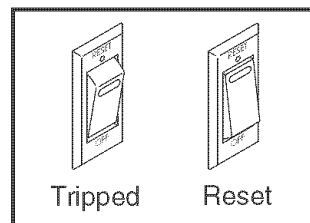

2. The power turns off during use

- Check the circuit breaker located on the treadmill frame near the power cord (see 1. c. above). If the circuit breaker has tripped, wait for five minutes and then press the switch back in.
- Make sure that the power cord is plugged in. If the power cord is plugged in, unplug it, wait for five minutes, and then plug it back in.
- Remove the key from the console and then reinsert it.
- Make sure that the reset/off circuit breaker is in the on position (see 1. d. above).

3. The walking belt slows when walked on

- Use only a single-outlet surge suppressor that meets all of the specifications described on page 8.
- If the walking belt is overtightened, treadmill performance may decrease and the walking belt may be permanently damaged. Remove the key and **UNPLUG THE POWER CORD**. Using the included allen wrench, turn both rear roller adjustment bolts counterclockwise 1/4 of a turn. When the walking belt is properly tightened, you should be able to lift the edges of the walking belt 3 to 4 inches off the walking platform. Be careful to keep the walking belt centered. Plug in the power cord, insert the key and run the treadmill for a few minutes. Repeat until the walking belt is properly tightened.

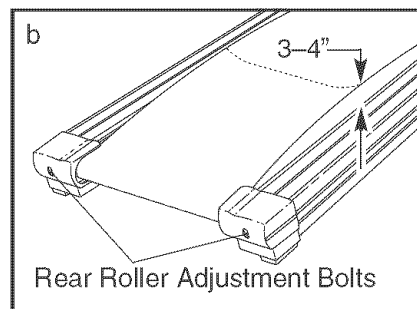

PROBLEM**SOLUTION**

4. The walking belt is off-center or slips when walked on

a. If the walking belt is off-center, first remove the key and **UNPLUG THE POWER CORD**. If the walking belt has shifted to the left, use the allen wrench to turn the left rear roller bolt clockwise 1/2 of a turn; if the walking belt has shifted to the right, turn the bolt counterclockwise 1/2 of a turn. Be careful not to overtighten the walking belt. Plug in the power cord, insert the key, and run the treadmill for a few minutes. Repeat until the walking belt is centered.

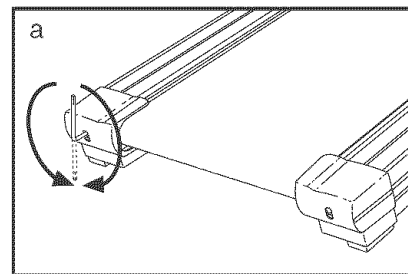

b. If the walking belt slips when walked on, first remove the key and **UNPLUG THE POWER CORD**. Using the allen wrench, turn both rear roller bolts clockwise 1/4 of a turn. When the walking belt is correctly tightened, you should be able to lift each side of the walking belt 3 to 4 inches off the walking platform. Be careful to keep the walking belt centered. Plug in the power cord, insert the key, and walk on the treadmill for a few minutes. Repeat until the walking belt is properly tightened.

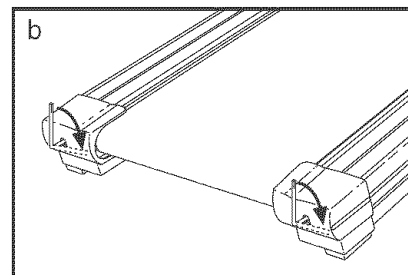

5. The displays of the console do not function properly

a. Remove the key from the console and **UNPLUG THE POWER CORD**. Next, remove the screws from the hood and carefully remove the hood. Locate the Reed Switch (17) and the Magnet (12) on the left side of the Pulley (11). Turn the Pulley until the Magnet is aligned with the Reed Switch. **Make sure that the gap between the Magnet and the Reed Switch is about 1/8"**. If necessary, loosen the indicated Screw (44) and move the Reed Switch slightly. Retighten the Screw. Re-attach the hood and run the treadmill for a few minutes to check for a correct speed reading.

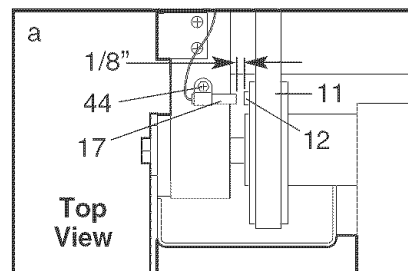

EXERCISE GUIDELINES

⚠️ WARNING: Before beginning this or any exercise program, consult your physician. This is especially important for individuals over the age of 35 or individuals with pre-existing health problems.

The pulse sensor is not a medical device. Various factors, including the user's movement, may affect the accuracy of heart rate readings. The pulse sensor is intended only as an exercise aid in determining heart rate trends in general.

The following guidelines will help you to plan your exercise program. For more detailed exercise information, obtain a reputable book or consult your physician.

EXERCISE INTENSITY

Whether your goal is to burn fat or to strengthen your cardiovascular system, the key to achieving the desired results is to exercise with the proper intensity. The proper intensity level can be found by using your heart rate as a guide. The chart below shows recommended heart rates for fat burning and aerobic exercise.

| HEART RATE TRAINING ZONES | | | | | | | |
|---------------------------|-----|-----|-----|-----|-----|-----|-----|
| AEROBIC | 165 | 155 | 145 | 140 | 130 | 125 | 115 |
| MAX FAT BURN | 145 | 138 | 130 | 125 | 118 | 110 | 103 |
| FAT BURN | 125 | 120 | 115 | 110 | 105 | 95 | 90 |
| Age | 20 | 30 | 40 | 50 | 60 | 70 | 80 |

To find the proper heart rate for you, first find your age near the bottom of the chart (ages are rounded off to the nearest ten years). Next, find the three numbers above your age. The three numbers define your "training zone." The lower two numbers are recommended heart rates for fat burning; the highest number is the recommended heart rate for aerobic exercise.

To measure your heart rate during exercise, use the handgrip pulse sensor. If your heart rate is too high or too low, adjust the speed or incline of the treadmill.

Fat Burning

To burn fat effectively, you must exercise at a relatively low intensity level for a sustained period of time. During the first few minutes of exercise, your body

uses easily accessible *carbohydrate calories* for energy. Only after the first few minutes does your body begin to use stored *fat calories* for energy. If your goal is to burn fat, adjust the speed or incline of the treadmill until your heart rate is near the lowest number in your training zone.

For maximum fat burning, adjust the speed or incline of the treadmill until your heart rate is near the middle number in your training zone.

Aerobic Exercise

If your goal is to strengthen your cardiovascular system, your exercise must be "aerobic." Aerobic exercise is activity that requires large amounts of oxygen for prolonged periods of time. This increases the demand on the heart to pump blood to the muscles, and on the lungs to oxygenate the blood. For aerobic exercise, adjust the speed or incline of the treadmill until your heart rate is near the highest number in your training zone.

WORKOUT GUIDELINES

Each workout should include the following three parts:

A Warm-up—Start each workout with 5 to 10 minutes of stretching and light exercise. A proper warm-up increases your body temperature, heart rate and circulation in preparation for exercise.

Training Zone Exercise—After warming up, increase the intensity of your exercise until your pulse is in your training zone for 20 to 60 minutes. (During the first few weeks of your exercise program, do not keep your pulse in your training zone for longer than 20 minutes.) Breathe regularly and deeply as you exercise—never hold your breath.

A Cool-down—Finish each workout with 5 to 10 minutes of stretching to cool down. This will increase the flexibility of your muscles and will help prevent post-exercise problems.

EXERCISE FREQUENCY

To maintain or improve your condition, complete three workouts each week, with at least one day of rest between workouts. After a few months, you may complete up to five workouts each week if desired. The key to success is to make exercise a regular and enjoyable part of your everyday life.

SUGGESTED STRETCHES

The correct form for several basic stretches is shown at the right. Move slowly as you stretch—never bounce.

1. Toe Touch Stretch

Stand with your knees bent slightly and slowly bend forward from your hips. Allow your back and shoulders to relax as you reach down toward your toes as far as possible. Hold for 15 counts, then relax. Repeat 3 times. Stretches: Hamstrings, back of knees and back.

2. Hamstring Stretch

Sit with one leg extended. Bring the sole of the opposite foot toward you and rest it against the inner thigh of your extended leg. Reach toward your toes as far as possible. Hold for 15 counts, then relax. Repeat 3 times for each leg. Stretches: Hamstrings, lower back and groin.

3. Calf/Achilles Stretch

With one leg in front of the other, reach forward and place your hands against a wall. Keep your back leg straight and your back foot flat on the floor. Bend your front leg, lean forward and move your hips toward the wall. Hold for 15 counts, then relax. Repeat 3 times for each leg. To cause further stretching of the achilles tendons, bend your back leg as well. Stretches: Calves, achilles tendons and ankles.

4. Quadriceps Stretch

With one hand against a wall for balance, reach back and grasp one foot with your other hand. Bring your heel as close to your buttocks as possible. Hold for 15 counts, then relax. Repeat 3 times for each leg. Stretches: Quadriceps and hip muscles.

5. Inner Thigh Stretch

Sit with the soles of your feet together and your knees outward. Pull your feet toward your groin area as far as possible. Hold for 15 counts, then relax. Repeat 3 times. Stretches: Quadriceps and hip muscles.

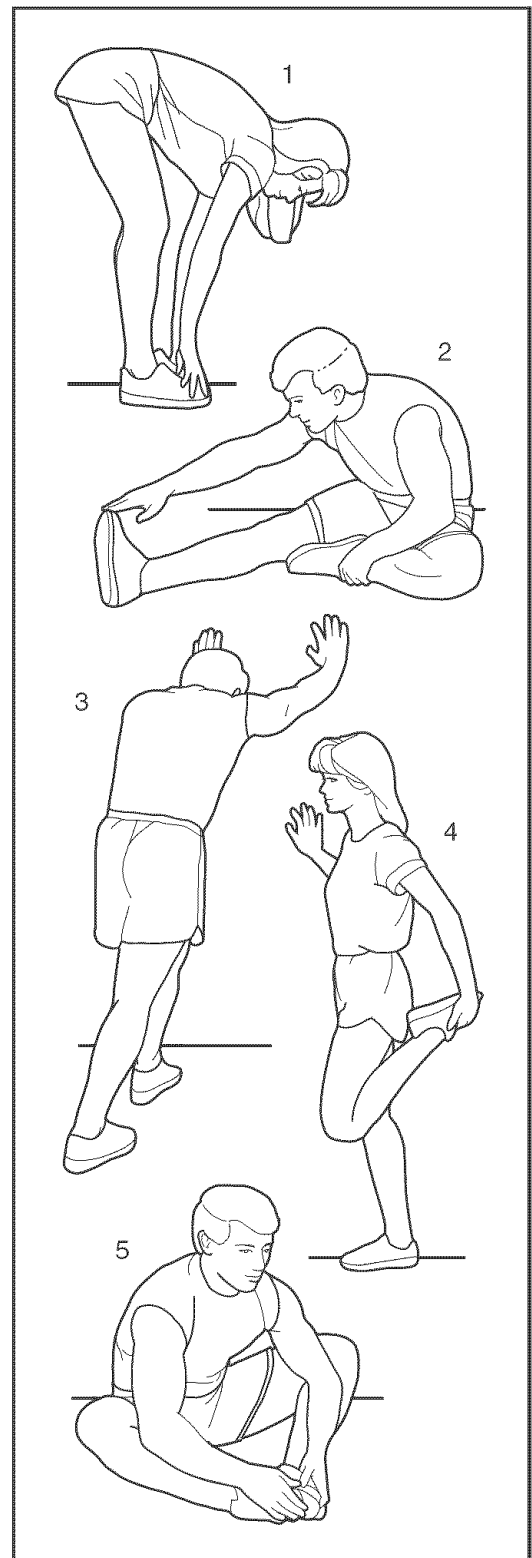

PART LIST—Model No. RBTL091040

R0904A

To locate the parts listed below, see the EXPLODED DRAWING attached in the center of this manual.

| Key No. | Qty. | Description | Key No. | Qty. | Description |
|---------|------|----------------------------------|---------|------|-----------------------------|
| 1 | 2 | Foot Rail | 51* | 2 | Cushion Assembly |
| 2 | 4 | Console Cover Screw | 52 | 2 | Roller Adj. Washer |
| 3 | 1 | Audio Wire | 53 | 2 | Rear Roller Adjustment Bolt |
| 4 | 4 | Isolator | 54 | 1 | Left Rear Endcap |
| 5 | 1 | Latch Housing Cover | 55 | 1 | Frame |
| 6 | 1 | Platform | 56 | 1 | Allen Wrench |
| 7 | 4 | Walking Platform Screw | 57 | 2 | Rear Platform Screw |
| 8 | 1 | Walking Belt | 58 | 1 | Rear Roller |
| 9 | 2 | Frame Pivot Bolt | 59* | 1 | Idler Assembly |
| 10 | 4 | Frame Pivot Washer | 60 | 1 | Audio Wire Nut |
| 11 | 1 | Front Wheel/Pulley | 61 | 1 | Pulse Bar |
| 12 | 1 | Magnet | 62 | 4 | Spring Nut |
| 13 | 7 | Front Roller Nut/Front Wheel Nut | 63 | 1 | Idler Arm |
| 14 | 2 | Spacer Insert | 64 | 1 | Idler Spring |
| 15 | 2 | Frame Pivot Spacer | 65 | 1 | Upright/Base |
| 16 | 1 | Reed Switch Clip | 66 | 4 | Belt Guide Screw |
| 17 | 1 | Reed Switch | 67 | 1 | Console Frame |
| 18 | 1 | Lift Frame | 68 | 1 | Latch Housing |
| 19 | 2 | Foot Rail Insert | 69 | 2 | Console Washer |
| 20 | 2 | Gear Rack | 70 | 1 | Spring Washer |
| 21 | 14 | Foot Rail Screw | 71 | 1 | Console Wire Harness |
| 22 | 1 | Motor Belt | 72 | 1 | iFIT.com Wire |
| 23 | 5 | Cushion Adj. Screw | 73 | 2 | Incline Pivot Bolt |
| 24 | 1 | Drive Motor | 74 | 1 | Flywheel |
| 25 | 1 | Transformer | 75 | 2 | Spring |
| 26 | 4 | Cushion Adj. Housing Screw | 76 | 2 | Spring Pad Screw |
| 27 | 4 | Hood Bracket | 77 | 2 | Front Wheel |
| 28 | 1 | Ground Wire | 78 | 2 | Wheel Bolt |
| 29 | 4 | Star Washer | 79 | 1 | Pulley Nut |
| 30 | 1 | Right Rear Endcap | 80 | 1 | Console |
| 31 | 1 | Lift Motor Bolt | 81 | 1 | Console Base |
| 32 | 2 | Motor Bolt | 82 | 2 | Fan |
| 33 | 1 | Outlet Bracket | 83 | 2 | Spring Pad |
| 34 | 1 | Left Inside Housing | 84 | 6 | Belly Pan Screw |
| 35 | 1 | Right Inside Housing | 85 | 1 | Upright Wire Harness |
| 36 | 1 | Right Outside Housing | 86 | 1 | Shock |
| 37 | 1 | Controller | 87 | 2 | Spring Plate Spacer |
| 38 | 1 | Controller Bracket | 88 | 2 | Upright Endcap |
| 39 | 1 | Motor Hood | 89 | 1 | Filter Wire |
| 40 | 56 | 3/4" Screw | 90 | 1 | Latch Warning Decal |
| 41 | 1 | Motor Belly Pan | 91 | 1 | Incline Motor |
| 42 | 2 | Belt Guide | 92 | 1 | Motor Controller Wire |
| 43 | 8 | 3/4" Tek Screw | 93 | 8 | Fan Screw |
| 44 | 20 | Electronics Screw | 94 | 1 | Tie Holder Screw |
| 45 | 1 | Left Front Endcap | 95 | 2 | Tie Holder |
| 46 | 1 | Right Front Endcap | 96 | 1 | Tie |
| 47 | 1 | Ground Screw | 97 | 5 | 8" Cable Tie |
| 48 | 2 | Rear Foot | 98 | 2 | Base Pad |
| 49 | 1 | Console Ground Wire | 99 | 1 | Idler Arm Bolt |
| 50* | 1 | Motor Assembly | 100 | 1 | Reset/Off Circuit Breaker |

| Key No. | Qty. | Description | Key No. | Qty. | Description |
|---------|------|-----------------------------|---------|------|-------------------------|
| 101 | 1 | Pulse Wire | 129 | 2 | Cushion Adj. Wheel |
| 102 | 1 | Power Cord | 130 | 1 | Cushion Adj. Knob |
| 103 | 1 | Power Cord Grommet | 131 | 5 | Cushion Adj. Screw |
| 104 | 2 | Warning Decal | 132 | 2 | 1/2" Screw |
| 105 | 2 | Spring Plate | 133 | 4 | Console Bolt |
| 106 | 1 | Jack | 134 | 4 | Pulse Bar Screw |
| 107 | 1 | iFIT.com Audio Cable | 135 | 1 | Access Door |
| 108 | 2 | Rear Roller Star Washer | 136 | 1 | Key/Clip |
| 109 | 1 | Pulley Washer | 137 | 2 | Wheel Housing |
| 110 | 1 | Idler Pulley | 138 | 1 | Right Handgrip (Bottom) |
| 111 | 1 | Pulley Spacer | 139 | 1 | Right Handgrip (Top) |
| 112 | 2 | Outlet Bracket Star Washer | 140 | 1 | Left Handgrip (Top) |
| 113 | 1 | Static Decal | 141 | 1 | Left Handgrip (Bottom) |
| 114 | 1 | Book Holder | 142 | 1 | Book Holder |
| 115 | 1 | Idler Pulley Bolt | 143 | 2 | 1/2" Tek Screw |
| 116 | 4 | Spring Washer | 144 | 4 | Foot Screw |
| 117 | 1 | Console Back | # | 1 | 8" Blue Wire, 2 F |
| 118* | 1 | Latch Assembly | # | 1 | 4" Blue Wire, M/F |
| 119 | 4 | Spring Bolt | # | 1 | 4" Blue Wire, 2 F |
| 120 | 2 | Cushion Adj. Pin | # | 1 | Blue Wire, M/F |
| 121 | 2 | Motor Bushing | # | 1 | 12" Green Wire, F/Ring |
| 122 | 1 | Idler Arm Nylon Washer | # | 1 | 8" Green Wire, 2 Ring |
| 123 | 2 | Cushion Adj. Rod | # | 1 | 14" White Wire, 2 F |
| 124 | 1 | Incline Bracket | # | 1 | 4" Black Wire, 2 F |
| 125 | 1 | Incline Motor Bolt (Bottom) | # | 1 | User's Manual |
| 126 | 2 | Controller Screw | | | |
| 127 | 1 | Motor Isolator Plate | | | |
| 128 | 2 | Cushion Adj. Gear | | | |

* Includes all parts shown in the box

These parts are not illustrated

ORDERING REPLACEMENT PARTS

To order replacement parts, call our Customer Service Department toll-free at 1-877-994-4999, Monday through Friday, 6 a.m. until 6 p.m. Mountain Time (excluding holidays). When ordering parts, please be prepared to give the following information:

- The MODEL NUMBER OF THE PRODUCT (RBTL091040)
- The NAME OF THE PRODUCT (REEBOK® 3500C treadmill)
- The SERIAL NUMBER of the product (see the front cover of this manual)
- The KEY NUMBER and DESCRIPTION of the part(s) (see the PART LIST on pages 30 and 31)

EXPLODED DRAWING—Model No. RBTL091040

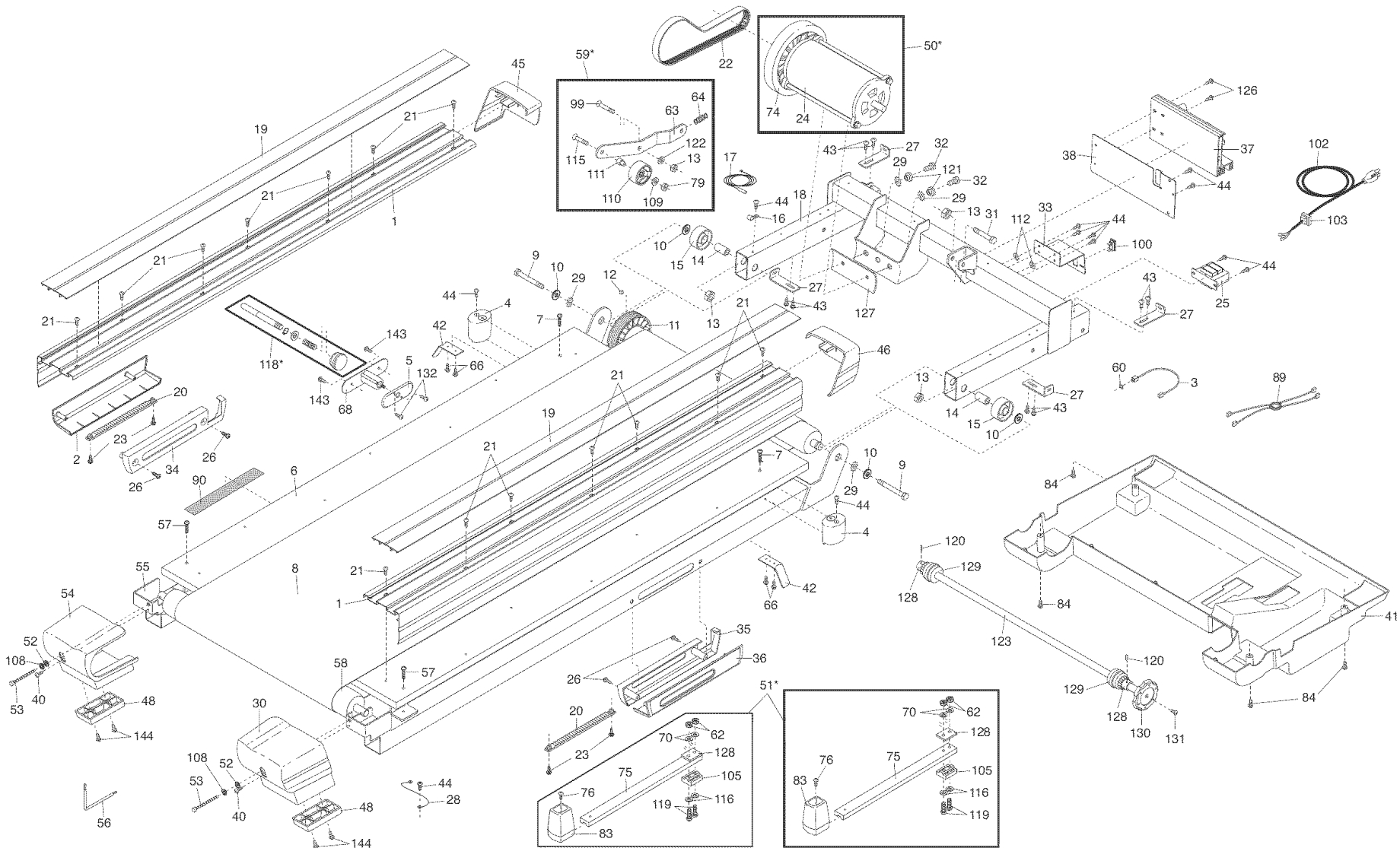

EXPLODED DRAWING—Model No. RBTL091040

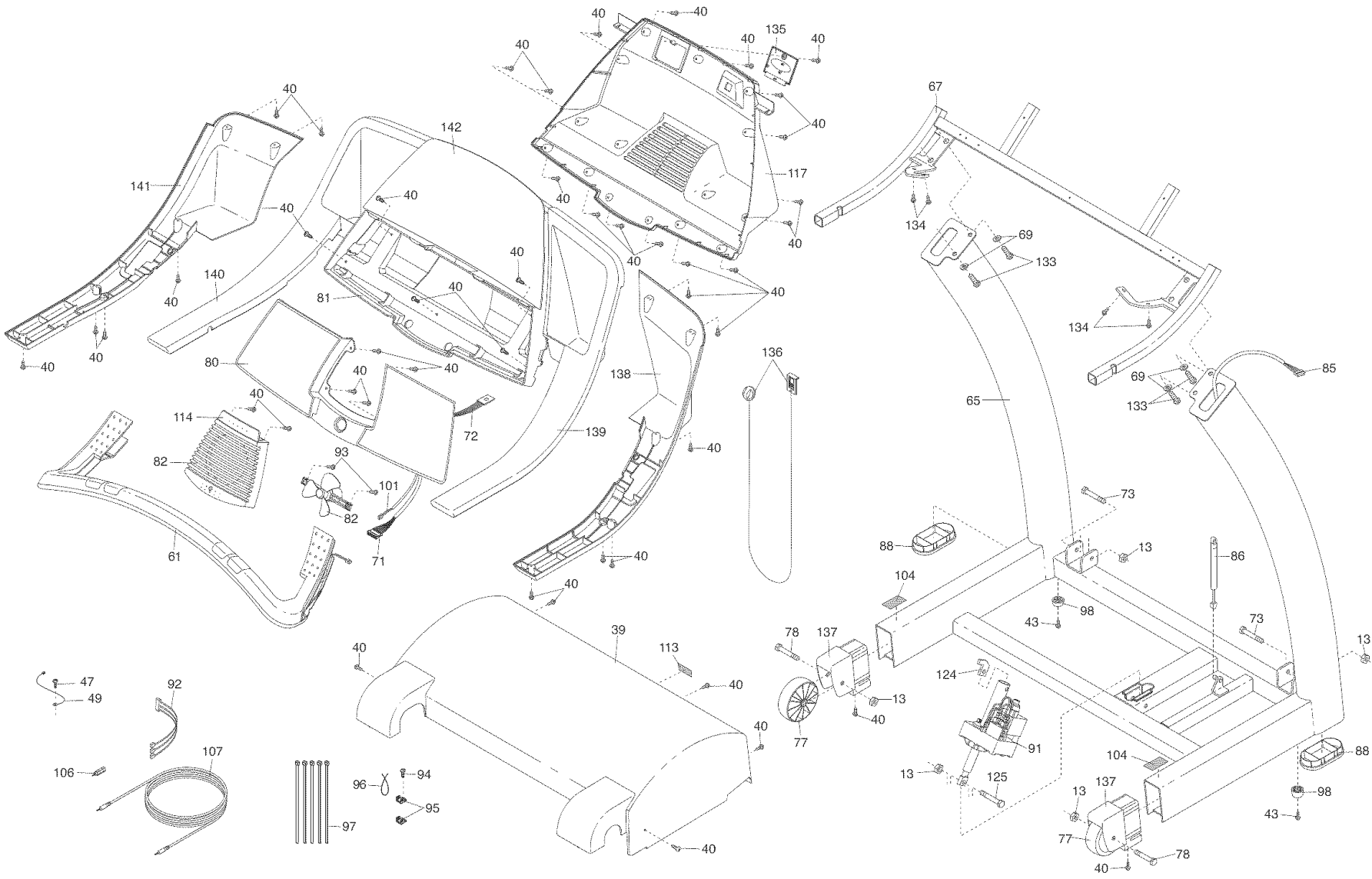

LIMITED WARRANTY

WHAT IS COVERED—The entire REEBOK® 3500C (“Product”) is warranted to be free of all defects in material and workmanship.

WHO IS COVERED—The original purchaser or any person receiving the Product as a gift from the original purchaser.

HOW LONG IS IT COVERED—ICON Health & Fitness, Inc. (“ICON”), warrants the drive motor for fifteen years after the date of purchase. Parts and labor are covered for one year after the date of purchase.

WHAT WE DO TO CORRECT COVERED DEFECTS—We will ship to you, without charge, any replacement part or component, providing the repairs are authorized by ICON first and are performed by an ICON trained and authorized service provider, or, at our option, we will replace the Product.

WHAT IS NOT COVERED—Any failures or damage caused by unauthorized service, misuse, accident, negligence, improper assembly or installation, alterations, modifications without our written authorization or by failure on your part to use, operate, and maintain as set out in your User’s Manual (“Manual”).

WHAT YOU MUST DO—Always retain proof of purchase, such as your bill of sale; store, operate, and maintain the Product as specified in the Manual; notify our Customer Service Department of any defect within 10 days after discovery of the defect; as instructed, return any defected part for replacement or, if necessary, the entire product, for repair.

USER’S MANUAL—It is VERY IMPORTANT THAT YOU READ THE MANUAL before operating the Product. Remember to do the periodic maintenance requirements specified in the Manual to assure proper operation and your continued satisfaction.

HOW TO GET PARTS AND SERVICE—Simply call our Customer Service Department at 1-877-994-4999 and tell them your name and address and the serial number of your Product. They will tell you how to get a part replaced, or if necessary, arrange for service where your Product is located or advise you how to ship the Product for service. Before shipping, always obtain a Return Authorization Number (RA No.) from our Customer Service Department; securely pack your Product (save the original shipping carton if possible); put the RA No. on the outside of the carton and insure the product. Include a letter explaining the product or problem and a copy of your proof of purchase if you believe the service is covered by warranty.

ICON is not responsible or liable for indirect, special or consequential damages arising out of or in connection with the use or performance of the product or damages with respect to any economic loss, loss of property, loss of revenues or profits, loss of enjoyment or use, costs of removal, installation or other consequential damages of whatsoever nature. Some states do not allow the exclusion or limitation of incidental or consequential damages. Accordingly, the above limitation may not apply to you.

The warranty extended hereunder is in lieu of any and all other warranties and any implied warranties of merchantability or fitness for a particular purpose is limited in its scope and duration to the terms set forth herein. Some states do not allow limitations on how long an implied warranty lasts. Accordingly, the above limitation may not apply to you.

No one is authorized to change, modify or extend the terms of this limited warranty.

This warranty gives you specific legal rights and you may have other rights which vary from state to state.

ICON HEALTH & FITNESS, INC., 1500 S. 1000 W., LOGAN, UT 84321-9813