

# Reebok® VISTA

Model No. RBTL13305.0

Serial No. \_\_\_\_\_

Write the serial number in the space above for future reference.

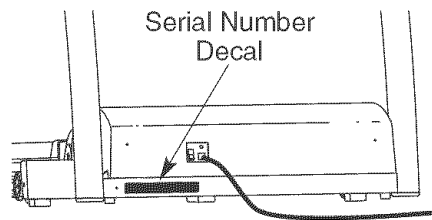

## USER'S MANUAL

### QUESTIONS?

As a manufacturer, we are committed to providing complete customer satisfaction. If you have questions, or if parts are damaged or missing, PLEASE CONTACT OUR CUSTOMER SERVICE DEPARTMENT DIRECTLY.

CALL TOLL-FREE:

**1-877-994-4999**

Mon.–Fri., 6 a.m.–6 p.m. MST

ON THE WEB:

[www.reebokservice.com](http://www.reebokservice.com)

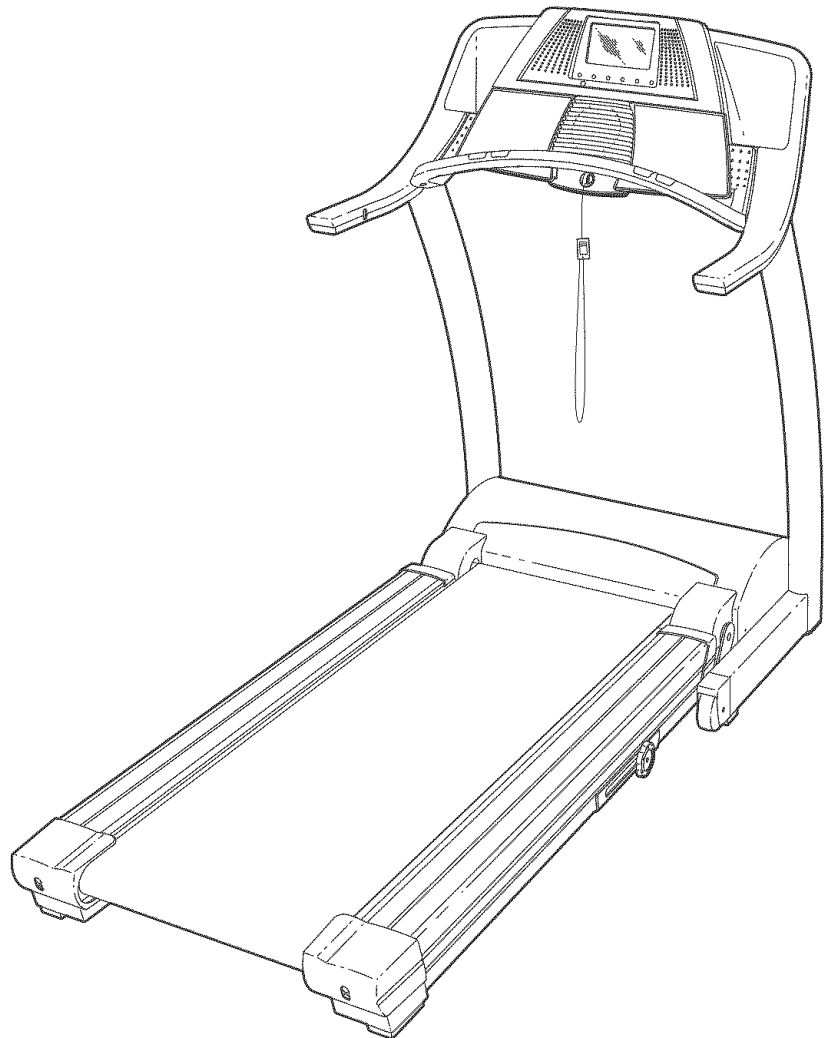

### ⚠ CAUTION

Read all precautions and instructions in this manual before using this equipment. Save this manual for future reference.



Visit our website at

[www.reebokhomefitness.com](http://www.reebokhomefitness.com)

*new products, prizes,  
fitness tips, and much more!*

# Reebok® VISTA

---

## TABLE OF CONTENTS

IMPORTANT PRECAUTIONS .....	3
BEFORE YOU BEGIN .....	6
ASSEMBLY .....	7
TREADMILL OPERATION .....	10
HOW TO FOLD AND MOVE THE TREADMILL .....	22
TROUBLESHOOTING .....	23
EXERCISE GUIDELINES .....	25
PART LIST .....	26
HOW TO ORDER REPLACEMENT PARTS .....	27
LIMITED WARRANTY .....	Back Cover

Note: An EXPLODED DRAWING is attached in the center of this manual.

# IMPORTANT PRECAUTIONS

**▲ WARNING:** To reduce the risk of burns, fire, electric shock, or injury to persons, read the following important precautions and information before operating the treadmill.

1. It is the responsibility of the owner to ensure that all users of this treadmill are adequately informed of all warnings and precautions.
2. Use the treadmill only as described in this manual.
3. Place the treadmill on a level surface, with at least eight feet of clearance behind it and two feet on each side. Do not place the treadmill on any surface that blocks air openings. To protect the floor or carpet from damage, place a mat under the treadmill.
4. Keep the treadmill indoors, away from moisture and dust. Do not put the treadmill in a garage or covered patio, or near water.
5. Do not operate the treadmill where aerosol products are used or oxygen is administered.
6. Keep children under the age of 12 and pets away from the treadmill at all times.
7. The treadmill should not be used by persons weighing more than 350 pounds. Never allow more than one person on the treadmill at a time.
8. Wear appropriate exercise clothes when using the treadmill. Do not wear loose clothes that could become caught in the treadmill. Athletic support clothes are recommended for both men and women. *Always wear athletic shoes. Never use the treadmill with bare feet, wearing only stockings, or in sandals.*
9. When connecting the power cord (see page 10), plug the power cord into a surge suppressor (not included) and plug the surge suppressor into a grounded circuit capable of carrying 15 or more amps. No other appliance should be on the same circuit. Do not use an extension cord.
10. Use only a single-outlet surge suppressor that meets all of the specifications described on page 10. To purchase a surge suppressor, see your local REEBOK dealer or call the toll-free telephone number on the front cover of this manual and order part number 146148, or see your local electronics store.
11. Failure to use a properly functioning surge suppressor could result in damage to the control system of the treadmill. If the control system is damaged, the walking belt may change speed, accelerate, or stop unexpectedly, which may result in a fall and serious injury.
12. Keep the power cord and the surge suppressor away from heated surfaces.
13. Never move the walking belt while the power is turned off. Do not operate the treadmill if the power cord or plug is damaged, or if the treadmill is not working properly. (See **BEFORE YOU BEGIN** on page 6 if the treadmill is not working properly.)
14. Read, understand, and test the emergency stop procedure before using the treadmill (see **TREADMILL OPERATION** on page 10).
15. Never start the treadmill while you are standing on the walking belt. Always hold the handrails while using the treadmill.
16. To protect the treadmill and TV during lightning storms, unplug the power cord from the wall outlet and disconnect the antenna or cable system. This will prevent damage due to lightning and power line surges.
17. The treadmill is capable of high speeds. Adjust the speed in small increments to avoid sudden jumps in speed.
18. The pulse sensor is not a medical device. Various factors, including the user's movement, may affect the accuracy of heart rate readings. The pulse sensor is intended only as an exercise aid in determining heart rate trends in general.
19. Never leave the treadmill unattended while it is running. Always remove the key, unplug the power cord, and move the reset/off circuit breaker to the "off" position when the treadmill is not in use. (See the drawing on page 6 for the location of the circuit breaker.)

20. Do not attempt to raise, lower, or move the treadmill until it is properly assembled. (See ASSEMBLY on page 7, and HOW TO FOLD AND MOVE THE TREADMILL on page 22.) You must be able to safely lift 45 pounds (20 kg) to raise, lower, or move the treadmill.
21. When folding or moving the treadmill, make sure that the storage latch is fully closed.
22. Inspect and properly tighten all parts of the treadmill every three months.
23. Never drop or insert any object into any opening.
24. **DANGER:** Always unplug the power cord immediately after use, before cleaning the treadmill, and before performing the maintenance and adjustment procedures described in this manual. Never remove the motor hood unless instructed to do so by an authorized service representative. Servicing other than the procedures in this manual should be performed by an authorized service representative only.
25. The treadmill is intended for in-home use only. Do not use the treadmill in any commercial, rental, or institutional setting.
26. If an outside antenna or cable system is connected, be sure that the antenna or cable system is grounded to provide some protection against voltage surges and built-up static charges. Section 810 of the National Electrical Code, ANSI/NFPA No. 70-1984, provides information with respect to proper grounding of the mast and supporting structure, grounding of the lead-in wire to an antenna discharge unit, size of grounding conductors, location of antenna discharge unit, connection to grounding electrodes, and requirements for the grounding electrode.
27. An outside antenna system should not be located in the vicinity of overhead power lines or other electric light or power circuits, or where it can fall into such power lines or circuits. When installing an outside antenna system, extreme care should be taken to keep from touching such power lines or circuits, as contact with them might be fatal.
28. To reduce the risk of electric shock, do not remove the cover or the back of the television. There are no user serviceable parts inside. Refer servicing to qualified service personnel.
29. Upon completion of any service or repairs to the treadmill or the television, ask the service technician to perform safety checks to confirm that the unit is in proper operating condition.
- Use No. 10 AWG (5.3mm<sup>2</sup>) copper, No. 8 AWG (8.4mm<sup>2</sup>) aluminum, No. 17 AWG (1.0mm<sup>2</sup>) copper-clad steel or bronze wire, or larger as a ground wire.
  - Secure an antenna lead-in and ground wires to the house with stand-off insulators spaced from 4 to 6 feet (1.22 to 1.83m) apart.
  - Mount an antenna discharge unit as close as possible to where the lead-in enters the house.
  - Use a jumper wire not smaller than No. 6 AWG (13.3mm<sup>2</sup>) copper, or the equivalent when a separate antenna-grounding electrode is used. See NEC Section 810-21 (j).
- Note to CATV system installer: This reminder is provided to call the CATV system installer's attention to Article 820-40 of the NEC that provides guidelines for proper grounding and, in particular, specifies that the cable ground shall be connected to the grounding system of the building, as close to the point of cable entry as practical.

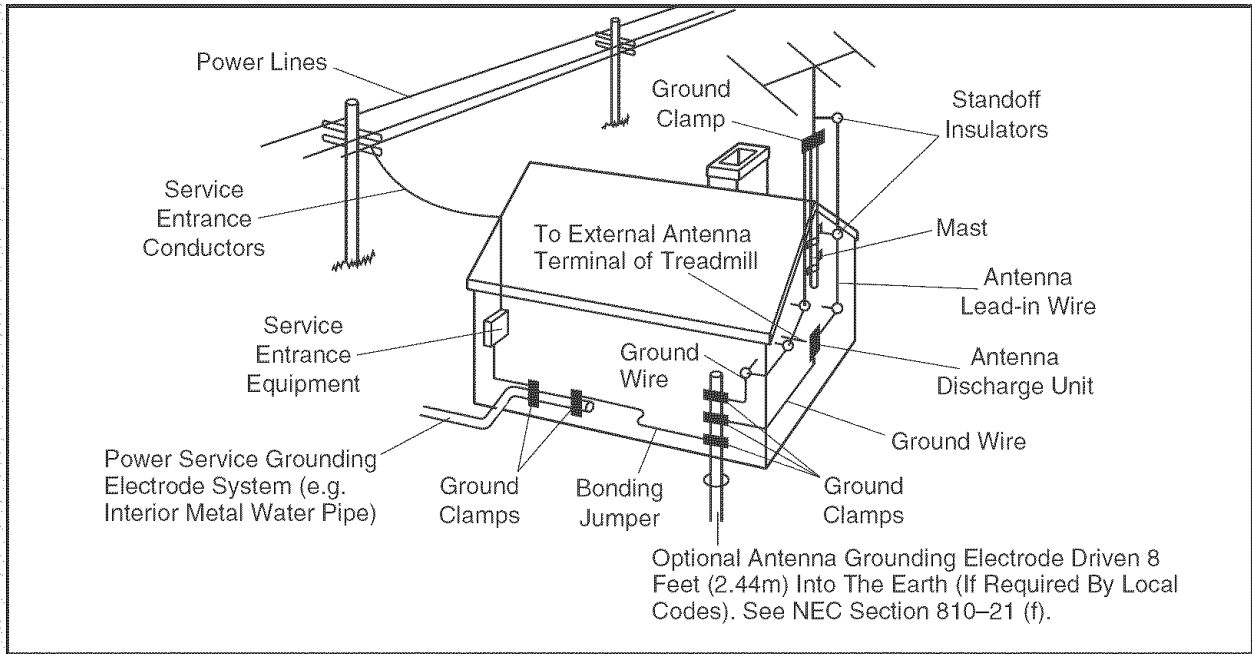

**⚠ WARNING:** Before beginning this or any exercise program, consult your physician. This is especially important for persons over the age of 35 or persons with pre-existing health problems. Read all instructions before using. ICON assumes no responsibility for personal injury or property damage sustained by or through the use of this product.

## SAVE THESE INSTRUCTIONS

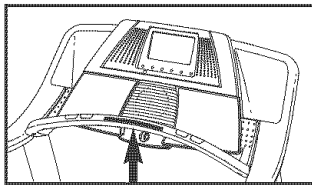

The decals shown here have been placed on the treadmill. If a decal is missing, or if it is not legible, call the toll-free telephone number on the front cover of this manual and order a free replacement decal. Apply the decal in the location shown. Note: The decals are not shown at actual size.

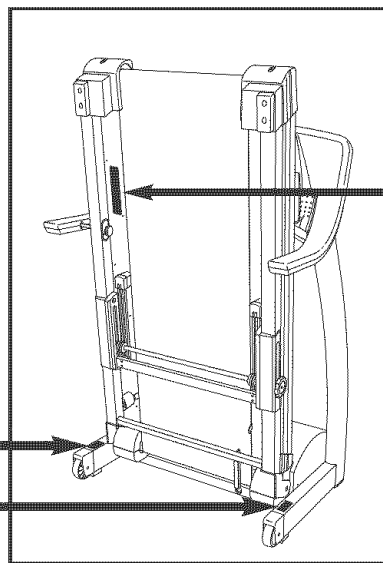

**⚠ WARNING:** To reduce risk of serious injury, stand on foot rails before starting treadmill, read and understand the user's manual, all instructions and the warnings before use. Keep children away. **IMPORTANT:** Incline must be set at lowest level before folding treadmill into storage position.



**⚠ WARNING:** Protect yourself and others from risk of serious injury. Read the user's manual and :

-  •Stand only on the side rails when starting or stopping treadmill.
- Change speed in small increments.
- Hold handrails to prevent falling, and always wear the safety clip while operating treadmill.
- Stop if you feel faint, dizzy, or short of breath.
- Fully engage storage latch before treadmill is moved or stored.
- Reduce incline to its lowest level before folding treadmill into storage position.
-  •Never allow children on or around treadmill.
- Remove key when not in use.
-  •Keep clothing, fingers, and hair away from moving belt.
- Never try to adjust or fix the belt while it is moving.
- Always wear athletic shoes while operating treadmill.

# BEFORE YOU BEGIN

Congratulations for purchasing the REEBOK® VISTA treadmill. The VISTA treadmill offers an impressive array of features designed to help you achieve your fitness goals in the convenience of your home. From the advanced console to the cushioned walking platform, the VISTA treadmill is designed to make each workout more effective and enjoyable. And when you're not exercising, the treadmill can be folded away, taking less than half the floor space of conventional treadmills.

**For your benefit, read this manual carefully before you use the treadmill.** If you have questions after reading this manual, please see the front cover of this

manual. To help us assist you, note the product model number and serial number before contacting us. The model number of the treadmill is RBTL13305.0. The serial number can be found on a decal attached to the treadmill (see the front cover of this manual for the location).

**To avoid a registration fee for any service needed under warranty, you must register the treadmill at [www.reebokservice.com/registration](http://www.reebokservice.com/registration).**

Before reading further, please review the drawing below and familiarize yourself with the labeled parts.

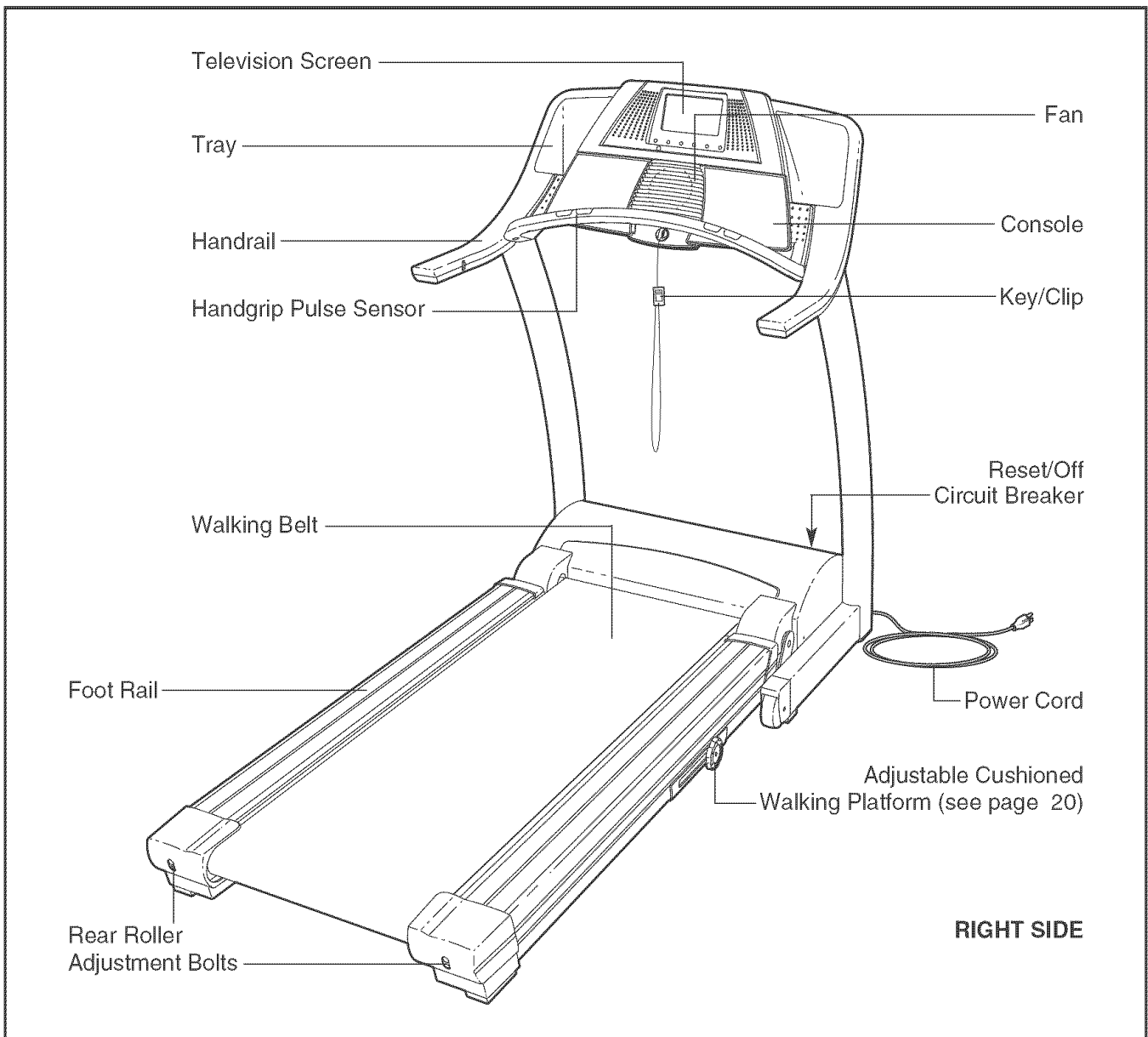

# ASSEMBLY

To hire an authorized service technician to assemble the treadmill, call toll-free 1-800-445-2480. Assembly requires two persons. Place the treadmill in a cleared area and remove all packing materials. Do not dispose of the packing materials until the treadmill is assembled.

Note: The underside of the treadmill walking belt is coated with high-performance lubricant. During shipping, a small amount of lubricant may be transferred to the top of the walking belt, the sides of the walking platform, or the shipping carton. This does not affect treadmill performance. If there is lubricant on top of the walking belt or on the sides of the walking platform, wipe off the lubricant with a soft cloth and a mild, non-abrasive cleaner.

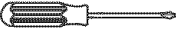
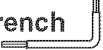
Assembly requires a phillips screwdriver  and the included allen wrench . To avoid damaging plastic parts, do not use power tools for assembly.

1. With the help of a second person, carefully raise the Uprights (65) to a vertical position.

Have the second person hold the console assembly near the Uprights (65) as shown. Look under the console assembly and locate the Console Wire Harness (71) and the TV cable.

Cut the plastic ties securing the Upright Wire Harness (85) and Upright TV Cable (100) to the Upright (65). Connect the Upright TV Cable to the TV cable in the console assembly. Connect the Upright Wire Harness to the Console Wire Harness (71). **Make sure to connect the connectors properly (see the inset drawing). The connectors should slide together easily and snap into place.** If the connectors do not slide together easily and snap into place, turn one connector and try again. **IF THE CONNECTORS ARE NOT CONNECTED PROPERLY, THE CONSOLE MAY BE DAMAGED WHEN THE POWER IS TURNED ON.**

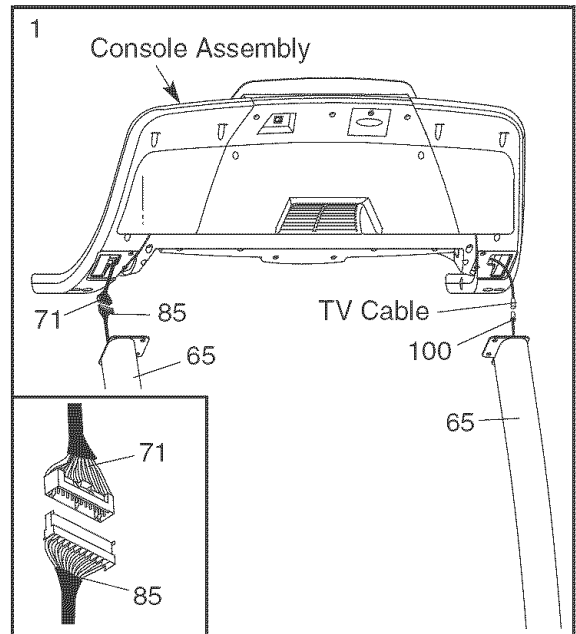

2. Insert the excess Wire Harnesses (71, 85) and TV cable into the Upright (65).

Set the console assembly on the Uprights (65). While a second person holds the console assembly, attach the console assembly with four 1" Console Bolts (133) and four Console Washers (69) as shown. Firmly tighten the Console Bolts.

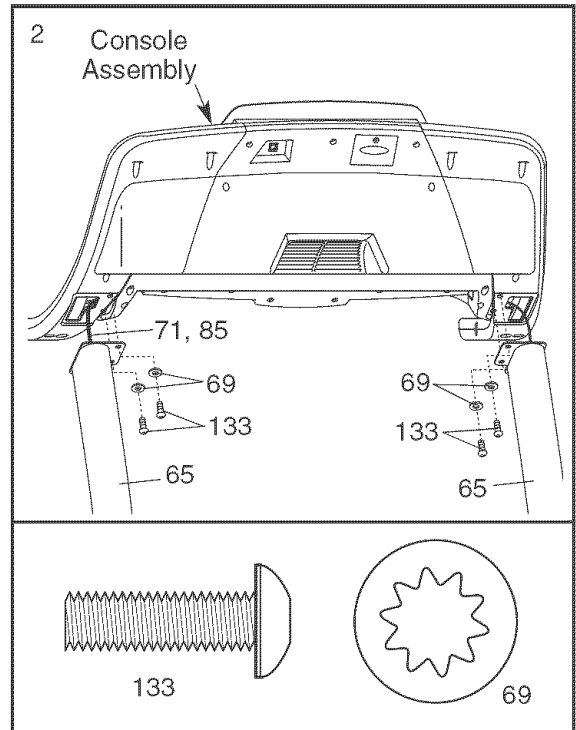

- With the help of a second person, raise the treadmill Frame (55). Hold the Latch Housing (68) and the Latch Housing Cover (5) against the sides of the Frame as shown. Loosely thread the two blunt-tipped 1/2" Screws (132) into the Latch Housing Cover and the Latch Housing as shown. **Do not tighten the Screws yet.**

Remove the knob from the pin. Make sure that the collar and the spring are on the pin. The collar should be on the side of the spring shown. Insert the pin into the Latch Housing (68), and tighten the knob back onto it.

Align the pin with the hole in the Left Handgrip (140) by sliding the Latch Housing (68) up or down. Make sure that the pin can be inserted fully into the hole. Hold the Latch Housing in place as you tighten two 1/2" Tek Screws (114) into the Latch Housing and the Frame (55). Then, tighten the 1/2" Screws (132). Note: It may be necessary to pull on the knob to access and tighten the Screws.

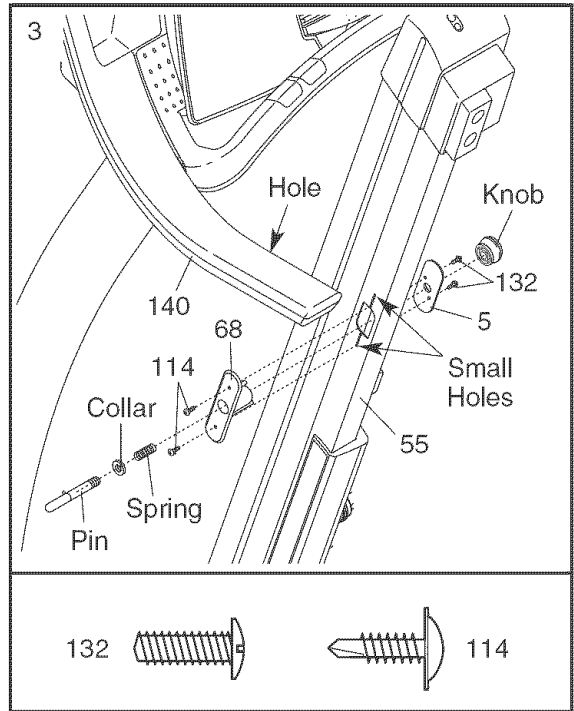

- Note the location of the 75 ohm antenna terminal on the treadmill. For the television to operate properly, an antenna, a CATV cable, or a VCR must be connected to the 75 ohm antenna terminal.

If you are using an antenna, it must be properly connected and adjusted for optimal reception. See ANTENNA CONNECTIONS on page 9 to properly connect an antenna. If you are using a CATV cable, see CATV CABLE CONNECTION on page 9 to properly connect the cable. If you are using a VCR, see HOW TO CONNECT A VCR on page 9 to properly connect the VCR. **The VCR must be turned on, a videocassette must be properly inserted, and the VCR must be playing. See your VCR user's manual for operating instructions.**

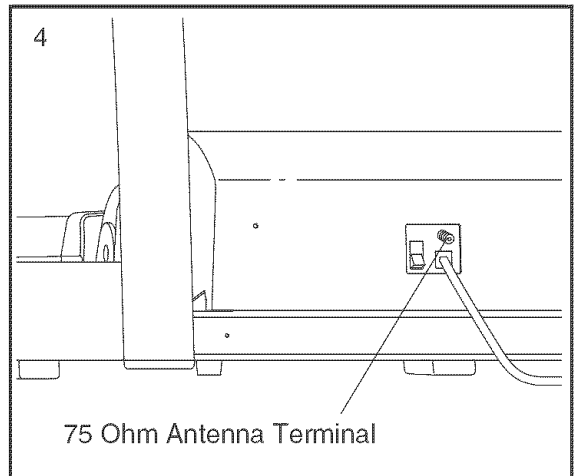

- Make sure that all parts are properly tightened before you use the treadmill. Place a mat beneath the treadmill to protect the floor or carpet. Note: Extra hardware may be included. Keep the included allen wrench in a secure place; the allen wrench is used to adjust the walking belt (see page 23). For your benefit, we recommend that you familiarize yourself with the TROUBLESHOOTING section on pages 23 and 24.



Before the personal television can be used, you must connect an antenna, a 75 ohm CATV cable, or a VCR to the 75 ohm antenna terminal on the treadmill frame. Note: No antenna, cable, or adapter is included.

### HOW TO CONNECT AN ANTENNA

#### Indoor Antenna

1. Place a VHF antenna in the desired location. Connect the 300 ohm flat wire from the antenna to a 300 ohm to 75 ohm adapter.

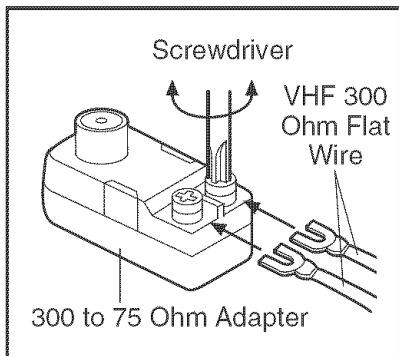

2. Push the 300 ohm to 75 ohm adapter onto the 75 ohm antenna terminal on the treadmill frame near the power cord.

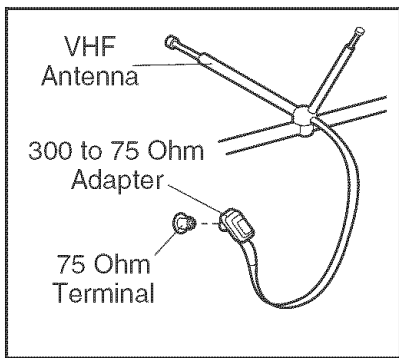

#### Outdoor Antenna

Note: Outdoor antennas are subject to weathering that can reduce signal quality. Inspect your antenna and the lead-in wiring before connecting the antenna.

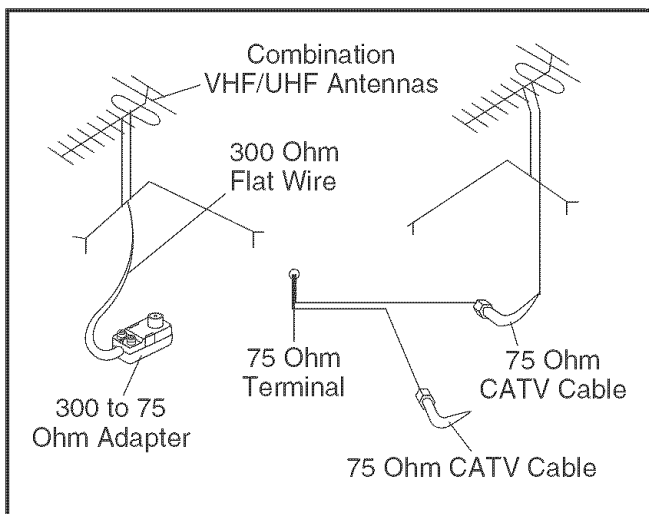

#### 300 Ohm Flat Wire

1. See the drawing near the bottom of this page. Connect the 300 ohm flat wire from the antenna to a 300 ohm to 75 ohm adapter.
2. Push the 300 ohm to 75 ohm adapter onto the 75 ohm antenna terminal on the treadmill frame near the power cord.

#### 75 Ohm CATV Cable

1. See the drawing near the bottom of this page. Connect the 75 ohm CATV cable from the antenna to the 75 ohm antenna terminal on the treadmill frame near the power cord.

### HOW TO CONNECT A 75 OHM CATV CABLE

1. Connect a 75 ohm CATV cable to the 75 ohm antenna terminal on the treadmill frame near the power cord.

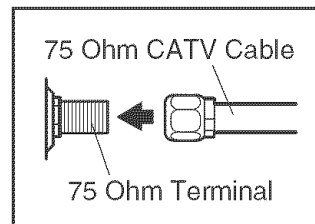

### HOW TO CONNECT A VCR

1. Connect one end of a 75 ohm CATV cable to the video output jack on your VCR.
2. Plug in the power cord of your VCR. See your VCR user's manual for proper grounding instructions.
3. Connect the 75 ohm CATV cable to the 75 ohm antenna terminal on the treadmill frame near the power cord.

Note: To operate the television with your VCR, make sure that channel 3 or 4 is selected.

# TREADMILL OPERATION

## THE PRE-LUBRICATED WALKING BELT

Your treadmill features a walking belt coated with high-performance lubricant. **IMPORTANT: Never apply silicone spray or other substances to the walking belt or the walking platform. Such substances will deteriorate the walking belt and cause excessive wear.**

## HOW TO PLUG IN THE POWER CORD

**⚠ DANGER:** Improper connection of the equipment-grounding conductor can result in an increased risk of electric shock. Check with a qualified electrician or serviceman if you are in doubt as to whether the product is properly grounded. Do not modify the plug provided with the product—if it will not fit the outlet, have a proper outlet installed by a qualified electrician.

Your treadmill, like any other type of sophisticated electronic equipment, can be seriously damaged by sudden voltage changes in your home's power. Voltage surges, spikes, and noise interference can result from weather conditions or from other appliances being turned on or off. **To decrease the possibility of your treadmill being damaged, always use a surge suppressor with your treadmill (see drawing 1 at the right).** To purchase a surge suppressor, see your local REEBOK dealer or call the toll-free telephone number on the front cover of this manual and order part number 146148, or see your local electronics store.

Use only a single-outlet surge suppressor that is UL 1449 listed as a transient voltage surge suppressor (TVSS). The surge suppressor must have a UL suppressed voltage rating of 400 volts or less and a minimum surge dissipation of 450 joules. The surge suppressor must be electrically rated for 120 volts AC and 15 amps. There must be a monitoring light on the surge suppressor to indicate whether it is functioning properly. Failure to use a properly functioning surge suppressor could result in damage to the control system of the treadmill. If the control system is damaged, the walking belt may change speed, accelerate, or stop unexpectedly, which may result in a fall and serious injury.

**This product must be grounded.** If it should malfunction or break down, grounding provides a path of least resistance for electric current to reduce the risk of elec-

tric shock. This product is equipped with a cord having an equipment-grounding conductor and a grounding plug. **Plug the power cord into a surge suppressor, and plug the surge suppressor into an appropriate outlet that is properly installed and grounded in accordance with all local codes and ordinances. Important: The treadmill is not compatible with GFCI-equipped outlets.**

This product is for use on a nominal 120-volt circuit, and has a grounding plug that looks like the plug illustrated in drawing 1 below. A temporary adapter that looks like the adapter illustrated in drawing 2 may be used to connect the surge suppressor to a 2-pole receptacle as shown in drawing 2 if a properly grounded outlet is not available.

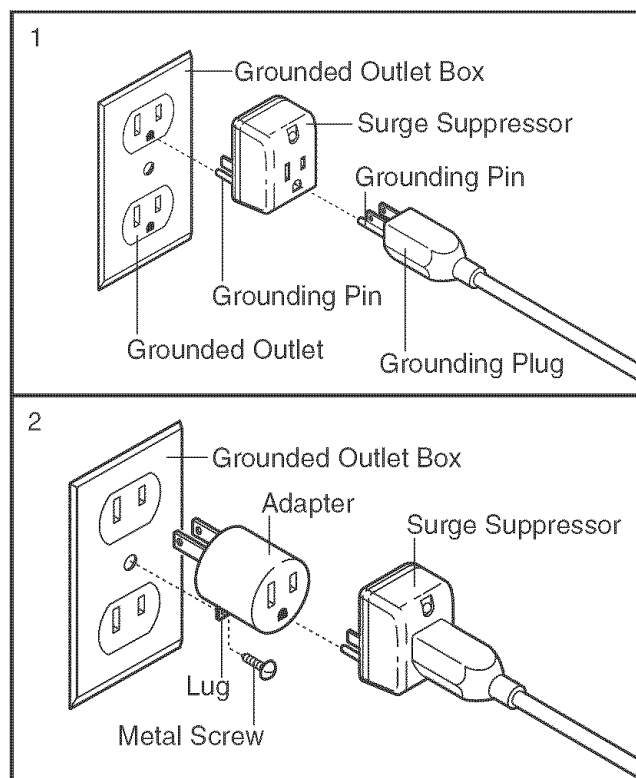

The temporary adapter should be used only until a properly grounded outlet (drawing 1) can be installed by a qualified electrician.

The green-colored rigid ear, lug, or the like extending from the adapter must be connected to a permanent ground such as a properly grounded outlet box cover. Whenever the adapter is used it must be held in place by a metal screw. **Some 2-pole receptacle outlet box covers are not grounded. Contact a qualified electrician to determine if the outlet box cover is grounded before using an adapter.**

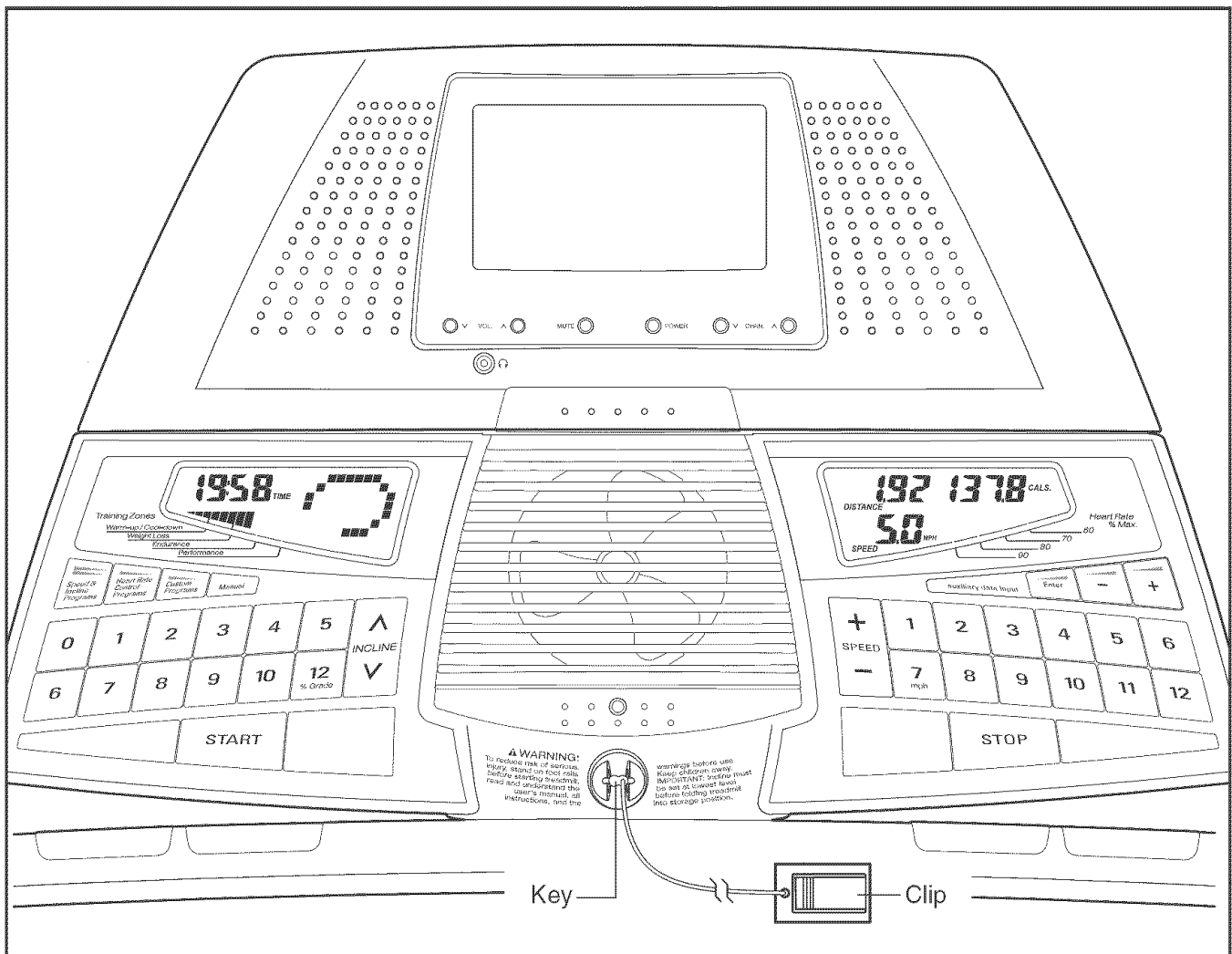

## FEATURES OF THE CONSOLE

The treadmill console offers an impressive array of features designed to help you get the most from your workouts.

When the manual mode of the console is selected, the speed and incline of the treadmill can be changed with the touch of a button. As you exercise, the console will display continuous exercise feedback. You can even measure your heart rate using the handgrip pulse sensor.

In addition, the console offers ten preset programs. Each program automatically controls the speed and incline of the treadmill as it guides you through an effective workout. You can even create custom workout programs and store them in memory for future use.

Four heart rate programs are also offered. Each program automatically adjusts the speed and incline of the

treadmill to keep your heart rate near target heart rate settings while you exercise.

Whether you select the manual mode or a program, you can enjoy the shows of your choice on the personal television while you get in shape.

**To use the manual mode of the console**, follow the steps beginning on page 12. **To use a preset program**, see page 14. **To create and use a custom program**, see pages 16 and 17. **To use a heart rate program**, see page 18. **To operate the personal television**, see page 20.

**Note:** If there is a sheet of clear plastic on the face of the console, peel off the plastic. To prevent damage to the walking platform, wear clean athletic shoes while using the treadmill. The first time the treadmill is used, observe the alignment of the walking belt, and center the walking belt if necessary (see page 24).

## HOW TO TURN ON THE POWER

Plug in the power cord (see page 10).

Next, locate the reset/off circuit breaker near the power cord. Make sure that the circuit breaker is in the reset position.

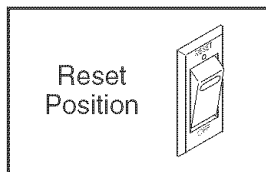

Stand on the foot rails of the treadmill. Find the clip attached to the key (see the drawing on page 11) and attach the clip securely to the waistband of your clothes. Next, insert the key into the console. After a moment, the displays will light, and after a few seconds, the television will turn on. **Important: In an emergency situation, the key can be pulled from the console, causing the walking belt to slow to a stop. Test the clip by carefully taking a few steps backward until the key is pulled from the console. If the key is not pulled from the console, adjust the position of the clip as needed.**

## HOW TO USE THE MANUAL MODE

### 1 Insert the key into the console.

See HOW TO TURN ON THE POWER above.

### 2 Select the manual mode.

When the key is inserted, the manual mode will be selected. If you have selected a program, press the Manual button to reselect the manual mode.

### 3 Start the walking belt.

To start the walking belt, press the Start button, the Speed increase button, or one of the twelve numbered Speed buttons.

If the Start button or the Speed increase button is pressed, the walking belt will begin to move at 1 mph. As you exercise, change the speed of the walking belt as desired by pressing the Speed increase and decrease buttons. Each time a button is pressed, the speed setting will change by 0.1 mph; if a button is held down, the speed setting will change in increments of 0.5 mph. Note: After the buttons are pressed, it may take a moment for the walking belt to reach the selected speed setting.

If one of the numbered Speed buttons is pressed, the walking belt will gradually increase in speed until it reaches the selected speed setting.

To stop the walking belt, press the Stop button. The time will begin to flash in the left display. To restart the walking belt, press the Start button, the Speed increase button, or one of the numbered Speed buttons.

### 4 Change the incline of the treadmill as desired.

To change the incline of the treadmill, press the Incline buttons. Each time a button is pressed, the incline will change by 0.5%. To change the incline setting quickly, press the numbered Incline buttons. Note: After the buttons are pressed, it may take a moment for the treadmill to reach the selected incline setting.

### 5 Follow your progress with the two displays.

**The left display**—This display will show the elapsed time, your pace (in minutes per mile), and the incline level of the treadmill. Note: When a program is selected, this display will show the time remaining in the program instead of the elapsed time. Each time the incline of the treadmill changes, the display will show the incline setting for several seconds.

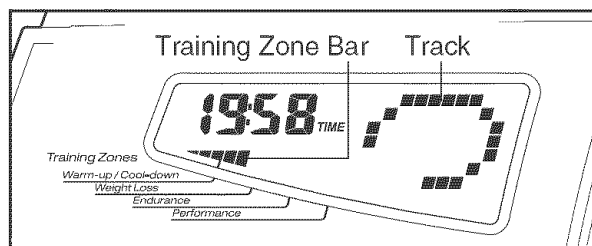

The left display will also show a training zone bar that indicates the approximate intensity of your exercise. For example, if four to six segments of the bar appear, the bar shows that your exercise intensity is ideal for weight loss.

When the manual mode is selected, the left display will also show a track. As you exercise, the indicators around the track will appear in succession until the entire track is lit. The track will then disappear the indicators will again begin to appear in succession.

**The right display**—This display will show the distance that you have walked or run, the number of 1/4-mile laps you have completed, the speed of the walking belt, and the approximate numbers of *calories* and *fat calories* you have burned (see *FAT BURNING* on page 25).

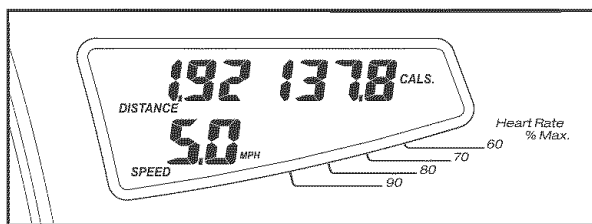

The right display will also show your heart rate when you use the handgrip pulse sensor. In addition, during heart rate programs the right display will show a heart rate bar that shows your heart rate as a percentage of your estimated maximum heart rate (see step 3 on page 18 for an explanation of your estimated maximum heart rate). For example, if four to six segments of the bar appear, your heart rate is between 60% and 70% of your estimated maximum heart rate.

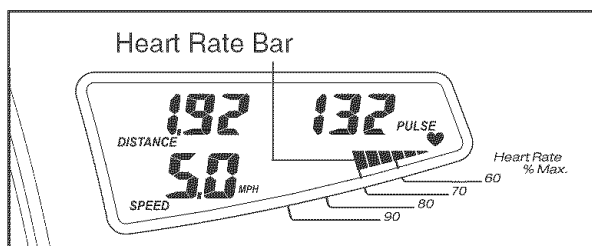

Note: The console can display speed and distance in either miles or kilometers. The letters "MPH" or "Km/H" will appear in the right display to show which unit of measurement is selected. To change the unit of measurement, see *HOW TO USE THE INFORMATION MODE* on page 20. **For simplicity, all instructions in this section refer to miles.**

To reset the displays, press the Stop button, remove the key, and then reinsert the key.

## 6 Measure your heart rate if desired.

Before using the handgrip pulse sensor, remove the sheets of clear plastic from the metal contacts. In addition,

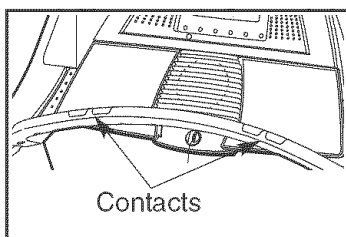

make sure that your hands are clean. Next, hold the handgrip pulse sensor with your palms resting on the metal contacts; **avoid moving your hands**. When your pulse is detected, the heart-shaped indicator in the right display will flash each time your heart beats, one or two dashes (— —) will appear, and then your heart rate will be shown. **For the most accurate heart rate reading, continue to hold the contacts for about 15 seconds.**

Note: The handgrip pulse sensor is intended to be used only for heart rate measurement. **Do not use the handgrip pulse sensor as a handlebar. Always hold the handrails for support when you are not measuring your heart rate.**

## 7 Turn on the fan if desired.

To turn on the fan, press the button below the fan. To turn on the fan at high speed, press the button a second time. To turn off the fan, press the button a third time. Note: If the fan is on when the walking belt is stopped, the fan will automatically turn off after a few minutes.

## 8 When you are finished exercising, remove the key from the console.

Step onto the foot rails, press the Stop button, and **adjust the incline of the treadmill to the lowest setting. The incline must be at the lowest setting when the treadmill is folded to the storage position or the treadmill will become damaged.** Next, remove the key from the console and put it in a secure place. **Note: If the displays remain lit after the key is removed, the console is in the "demo" mode. See HOW TO USE THE INFORMATION MODE on page 20 and turn off the demo mode.**

**When you are finished using the treadmill, switch the reset/off circuit breaker to the "off" position and unplug the power cord.**

## HOW TO USE A PRESET PROGRAM

### 1 Insert the key into the console.

See HOW TO TURN ON THE POWER on page 12.

### 2 Select a preset program.

To select a preset program, press the Speed & Incline Programs button repeatedly. The right display will show which preset program (P-1 through P-10) is selected.

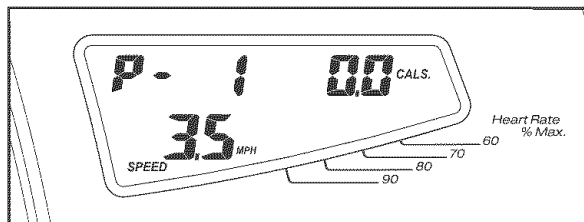

When a preset program is selected, the left display will flash the maximum incline setting of the program for a few seconds, and the right display will flash the maximum speed setting. The left display will then show how long the program will last. In addition, the first ten speed settings of the program will appear the matrix in the left display.

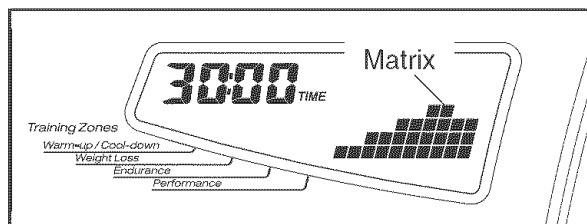

### 3 Press the Start button or the Speed increase button to start the program.

A moment after the button is pressed, the treadmill will automatically adjust to the first speed and incline settings of the program. Hold the handrails and begin walking.

Each program is divided into several one-minute segments. One speed setting and one incline setting are programmed for each segment. Note: The same speed setting and/or incline setting may be programmed for two or more consecutive segments.

The speed setting for the first segment will be shown in the flashing Current Segment column of the matrix. (The incline settings are not shown in the matrix.) The speed settings for the next seven segments will be shown in the columns at the right.

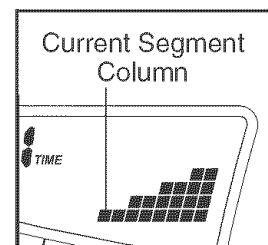

When only three seconds remain in the first segment of the program, both the Current Segment column and the column to the right will flash, and a series of tones will sound. If the speed and/or incline of the treadmill is about to change, the left display and/or the right display will flash to alert you. When the first segment ends, *all speed settings in the matrix will move one column to the left*. The speed setting for the second segment will then be shown in the flashing Current Segment column, and the treadmill will automatically adjust to the speed and incline settings for the second segment. Note: If all of the indicators in the Current Segment column are lit after the speed settings have moved to the left, *the speed settings may move downward* so that only the highest indicators appear in the matrix. If some indicators in the Current Segment column are not lit when the speed settings move to the left again, the speed settings will move back up.

The program will continue in this way until the speed setting for the last segment is shown in the Current Segment column and the last segment ends. The walking belt will then slow to a stop.

If the speed or incline setting is too high or too low at any time during the program, you can manually override the setting by pressing the Speed or Incline buttons. Every few times a Speed button is pressed, an additional indicator will appear or disappear in the Current Segment column. (If any of the columns to the right of the Current Segment column have the same number of indicators as the Current Segment column, an additional indicator may appear or disappear in those columns as well.) **Note: When the next segment of the program begins, the treadmill will automatically adjust to the speed and incline settings for the next segment.**

To stop the program at any time, press the Stop button. The time will begin to flash in the left display. To restart the program, press the Start button or the Speed increase button. The walking belt will begin to move at 1 mph. When the next segment of the program begins, the treadmill will automatically adjust to the speed and incline settings for the next segment.

**4 Follow your progress with the displays.**

See step 5 on page 12.

**5 Measure your heart rate if desired.**

See step 6 on page 13.

**6 Turn on the fan if desired.**

See step 7 on page 13.

**7 When you are finished exercising, remove the key from the console.**

When the program ends, **make sure that the incline of the treadmill is at the lowest setting.** Next, remove the key from the console and put it in a secure place. **Note: If the displays and various indicators remain lit after the key is removed, the console is in the “demo” mode. See HOW TO USE THE INFORMATION MODE on page 20 and turn off the demo mode.**

**When you are finished using the treadmill, switch the reset/off circuit breaker to the “off” position and unplug the power cord.**

## HOW TO CREATE A CUSTOM PROGRAM

### 1 Insert the key into the console.

See HOW TO TURN ON THE POWER on page 12.

### 2 Select a custom program.

To select a custom program, press the Custom Programs button repeatedly until "P-15" or "P-16" appears in the right display.

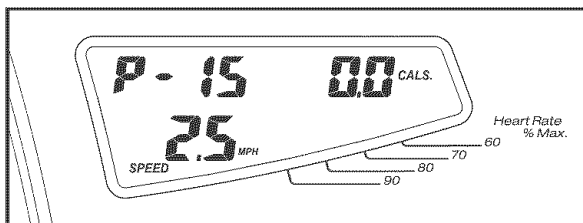

If the custom program has not yet been defined, three columns of indicators will appear in the matrix in the left display. **If more than three columns of indicators appear, see HOW TO USE A CUSTOM PROGRAM on page 17.**

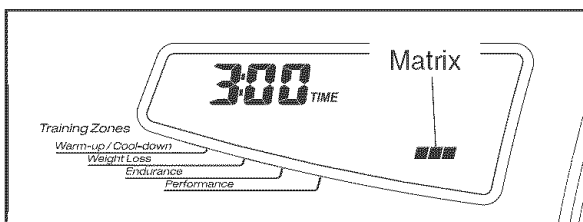

### 3 Press the Start button or the Speed increase button and program the desired speed and incline settings.

A moment after the button is pressed, the walking belt will begin to move. Hold the handrails and begin walking.

See the matrix in the left display. Each custom program is divided into one-minute segments. One speed setting and one incline setting can be programmed for each segment. The speed setting for the first segment will be shown in the flashing Current Segment column of the matrix. (The incline settings are not shown in the matrix.) To program a speed setting and an incline setting for the first segment, simply adjust the speed and incline of the treadmill as desired by pressing the Speed and Incline buttons. Every few times a Speed button is pressed, an additional indicator will appear or disappear in the Current Segment column.

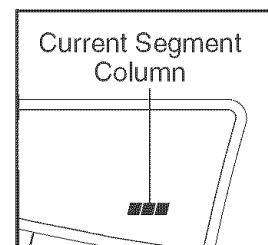

When the first segment of the program ends, the current speed setting and the current incline setting will be stored in memory. *The three columns of indicators will then move one column to the left, and the speed setting for the second segment will be shown in the flashing Current Segment column.* Program a speed setting and an incline setting for the second segment as described above.

Continue programming speed and incline settings for as many segments as desired; custom programs can have up to forty segments. When you are finished with your workout, press the Stop button twice. The speed and incline settings that you have programmed and the number of segments that you have programmed will then be saved in memory.

### 4 When you are finished exercising, remove the key from the console.

See step 7 on page 15.



## HOW TO USE A CUSTOM PROGRAM

### 1 Insert the key into the console.

See HOW TO TURN ON THE POWER on page 12.

### 2 Select a custom program.

To select a custom program, press the Custom Programs button repeatedly until "P-15" or "P-16" appears in the right display.

When a custom program is selected, the left display will flash the maximum incline setting of the program for a few seconds, and the right display will flash the maximum speed setting. The left display will then show how long the program will last. In addition, the first ten speed settings of the program will appear in the matrix in the left display.

**Note: If only three columns of indicators appear, see HOW TO CREATE A CUSTOM PROGRAM on page 16.**

### 3 Press the Start button or the Speed increase button to start the program.

A moment after the button is pressed, the treadmill will automatically adjust to the first speed and incline settings that you programmed previously. Hold the handrails and begin walking.

Each program is divided into several one-minute segments. One speed setting and one incline setting are programmed for each segment. The speed setting for the first segment will be shown in the flashing Current Segment column of the matrix. (The incline settings are not shown in the matrix.) The speed settings for the next several segments will be shown in the columns to the right.

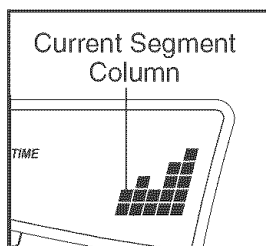

When only three seconds remain in the first segment of the program, both the Current Segment column and the column to the right will flash, a se-

ries of tones will sound, the speed setting and the incline setting will flash in the displays, and *all speed settings will move one column to the left*. The speed setting for the second segment will then be shown in the flashing Current Segment column and the treadmill will automatically adjust to the second speed and incline settings that you programmed previously.

The program will continue until the speed setting for the last segment is shown in the Current Segment column and the last segment ends. The walking belt will then slow to a stop.

If desired, you can redefine the program while using it. **To change the speed or incline setting during the current segment**, simply press the Speed or Incline buttons. When the current segment ends, the new setting will be saved in memory. **To increase the length of the program**, first wait until the program ends. Then, press the Start button, and program speed and incline settings for as many additional segments as desired. When you have added as many segments as desired, press the Stop button twice. **To decrease the length of the program**, press the Stop button twice at any time before the program ends.

To stop the program at any time, press the Stop button. The time will begin to flash in the left display. To restart the program, press the Start button or the Speed increase button.

### 4 Follow your progress with the displays.

See step 5 on page 12.

### 5 Measure your heart rate if desired.

See step 6 on page 13.

### 6 Turn on the fan if desired.

See step 7 on page 13.

### 7 When you are finished exercising, remove the key from the console.

See step 7 on page 15.

## HOW TO USE A HEART RATE PROGRAM

**CAUTION:** If you have heart problems, or if you are over 60 years of age and have been inactive, do not use the heart rate programs. If you are taking medication regularly, consult your physician to find whether the medication will affect your exercise heart rate.

Follow the steps below to use a heart rate program.

### 1 Insert the key into the console.

See HOW TO TURN ON THE POWER on page 12.

### 2 Select a heart rate program.

To select a heart rate program, press the Heart Rate Control Programs button repeatedly until "P-11," "P-12," "P-13," or "P-14" appears in the right display.

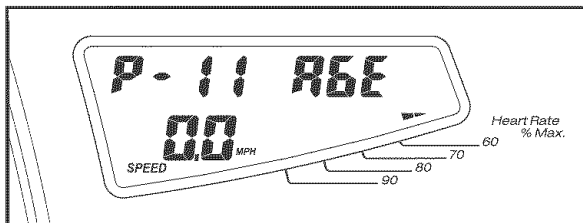

If heart rate program 11 is selected, a pulse symbol will scroll across the matrix in the left display. If heart rate program 12, 13, or 14 is selected, a profile of the target heart rate settings of the program will appear in the matrix in the left display.

Note: During heart rate program 11, your heart rate will remain near a target heart rate setting that you select. During heart rate programs 12, 13, or 14, your heart rate will reach approximately 85% of your *estimated maximum heart rate*. Note: Your maximum heart rate is estimated by subtracting your age from 220. For example, if you are 30 years old, your estimated maximum heart rate is 190 beats per minute ( $220 - 30 = 190$ ).

### 3 Enter your age.

When a heart rate program is selected, the word "AGE" and the current age setting will begin to flash in the right display. If you have already entered your age, press the Enter button. If you have not entered your age, press the + or – button beside the Enter button to enter your age, and then press the Enter button.

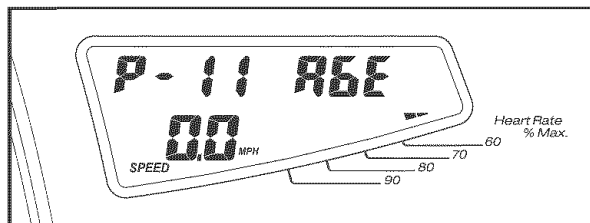

### 4 Enter a target heart rate setting for the program.

If heart rate program 11 is selected, the letters "PLS" and the target heart rate setting for the program will begin to flash in the right display. If desired, change the target heart rate setting by pressing the + or – button beside the Enter button (see EXERCISE INTENSITY on page 25). Then, press the Enter button.

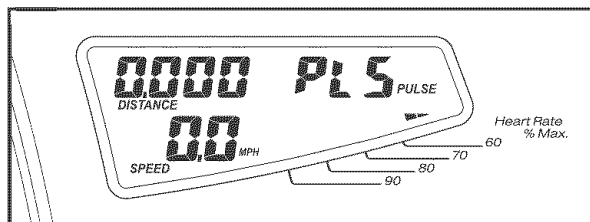

If heart rate program 12, 13, or 14 is selected, the letters "PLS" and the maximum target heart rate setting for the program will begin to flash in the right display. If desired, change the maximum target heart rate setting by pressing the + or – button beside the Enter button (see EXERCISE INTENSITY on page 25). Then, press the Enter button. Note: If the maximum target heart rate setting is changed, the intensity level of the entire program will change.

**5 Hold the handgrip pulse sensor.**

It is not necessary to hold the handgrip pulse sensor continuously during a pulse program; however, you must hold the handgrip pulse sensor frequently. **Each time you hold the handgrip pulse sensor, keep your hands on the metal contacts for at least 15 seconds.** Note: When you are not holding the handgrip pulse sensor, the letters "PLS" will appear in the display instead of your heart rate.

**6 Press the Start button or the Speed increase button to start the program.**

A moment after the button is pressed, the treadmill will automatically adjust to the first speed and incline settings of the program. Hold the handrails and begin walking.

**Heart rate program 11** is divided into several one-minute segments. The same target heart rate setting is programmed for all segments. (For a shorter workout, simply stop the program before it ends.) **Heart rate programs 12, 13, and 14** are divided into either 20 or 30 one-minute segments. One target heart rate setting is programmed for each segment. Note: The same target heart rate setting may be programmed for two or more consecutive segments.

If heart rate program 12, 13, or 14 is selected, the target heart rate setting for the first segment will be shown in the flashing Current Segment column of the matrix. The target heart rate settings for the next several segments will be shown in the columns to the right. When only three seconds remain in the first segment of the program, both the Current Segment column and the column to the right will flash and a series of tones will sound.

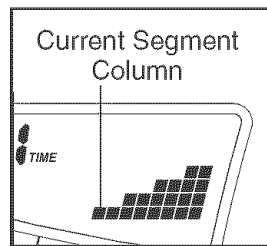

When the first segment ends, *all target heart rate settings will move one column to the left.* The target heart rate setting for the second segment will then be shown in the flashing Current Segment column.

**During all heart rate programs,** the console will regularly compare your heart rate to the target heart rate setting for the current segment. If your heart rate is too far below or above the target heart rate setting, the speed of the walking belt will automatically increase or decrease to bring your heart rate closer to the target heart rate setting.

If the speed or incline setting is too high or too low at any time during the program, you can adjust the setting with the Speed or Incline buttons. However, when the console compares your heart rate to the target heart rate setting, the speed of the treadmill may automatically change to bring your heart rate closer to the target heart rate setting.

If your pulse is not detected during the program, the letters "PLS" will flash in the right display and the speed of the treadmill may automatically decrease.

To stop the program at any time, press the Stop button. To restart the program, press the Start button or the Speed increase button. The walking belt will begin to move at 1 mph. When the console compares your heart rate to the target heart rate setting, the speed and/or incline of the treadmill may automatically change to bring your heart rate closer to the target heart rate setting.

**7 Follow your progress with the displays.**

See step 5 on page 12.

**8 Turn on the fan if desired.**

See step 7 on page 13.

**9 When you are finished exercising, remove the key from the console.**

See step 7 on page 15.

## HOW TO OPERATE THE PERSONAL TELEVISION

**IMPORTANT:** Before operating the television, you must connect an antenna, a 75 ohm CATV cable, or a VCR to the 75 ohm antenna terminal on the treadmill. See page 9 for instructions.

Follow the steps below to operate the television.

### **1** Insert the key into the console.

See HOW TO TURN ON THE POWER on page 12.

### **2** Press the Power button to turn on the television.

When the key is inserted, the television will automatically turn on. If you have turned off the television, turn it on by pressing the Power button.

### **3** Press the Channel buttons to select the desired channel.

When the television is turned on, the screen will show the last channel that was selected. To select a different channel, press the Channel buttons. The selected channel number will appear on the screen for a few seconds. Note: The television is equipped with a channel memorizing function that allows you to go directly from the current channel to the next channel saved in memory. Before channels can be selected in this way, they must be saved in the television's memory. See HOW TO USE THE INFORMATION MODE at the right.

### **4** Press the Volume buttons to adjust the volume.

When either Volume button is pressed, the volume level indicator will appear on the screen for a few seconds. To temporarily mute the sound, press the Mute button. Press the Mute button again to listen to the television. Note: To use earphones or headphones (not included), plug them into the headphone jack on the console.

### **5** When you are finished using the television, press the Power button.

Press the Power button to turn off the television. Note: Removing the key from the console will also turn off the television.

## HOW TO USE THE INFORMATION MODE

The console features an information mode that allows you to view treadmill usage information, select a system of measurement for the console, and turn on and turn off the demo mode. The information mode also allows you to adjust the settings of the television and to save channels into the television's memory.

Follow the steps below to use the information mode.

### **1** Hold down the Stop button while inserting the key into the console.

When the information mode is selected, the left display will show the total number of hours that the treadmill has been used. The right display will show the total number of miles or kilometers that the walking belt has moved.

In addition, the right display will show the letter "E" for English miles or the letter "M" for metric kilometers. Press the Speed increase button to change the unit of measurement if desired.

**IMPORTANT:** If the letter "d" appears in the right display, the "demo" mode is selected. This mode is intended to be used only when a treadmill is displayed in a store. When the demo mode is selected, the power cord can be plugged in, the key can be removed from the console, and the displays and indicators on the console will automatically light in a preset sequence. The buttons on the console will not function. **If a "d" appears in the right display when the information mode is selected, press the Speed decrease button.**

### **2** Press the Power button and adjust the brightness, contrast, color, sharpness, and/or hue of the television.

When the Power button is pressed, the brightness level indicator will appear on the television screen. Press the Volume buttons to adjust the brightness setting if desired.

Next, press the Channel buttons until the contrast, color, sharpness, or hue level indicator appears. Adjust the settings, if desired, by pressing the Volume buttons.

**3 Press the Power button again and add or delete channels.**

After all valid channels available in your area have been saved into the television's memory (see step 5 on page 21), you can manually add channels or delete unwanted channels.

To add or delete a channel, first press the Channel buttons until the desired channel number appears on the screen. Then, press the Volume increase button to add the channel, or the Volume decrease button to delete the channel. Continue this process until you have added all desired channels and deleted all unwanted channels.

**4 Press the Power button again and select an antenna connection or a cable connection.**

After the Power button is pressed, press the Volume decrease button to select the Air setting, the Volume increase button to select the Standard Cable setting, the Channel decrease button to select the Cable IRC setting, or the Channel increase button to select the Cable HRC setting. Note: The setting that you select will **not** appear on the screen. If you have connected an antenna to the treadmill, the Air setting should be selected. If you have connected a CATV cable, one of the three Cable settings should be selected; try all three Cable settings, if necessary, to find the optimal setting.

**5 Press the Power button again and save channels into the television's memory.**

When the Power button is pressed, the television will begin scanning all of the channels available in

your area. When no broadcast signal is detected on a channel, the channel will be skipped. When a broadcast signal is detected, the channel will be saved into memory and the next channel will be selected. This process will continue until the highest channel is reached. **Do not remove the key while the television is scanning channels.**

**6 When you are finished using the information mode, remove the key.**

To exit the information mode at any time (except while the television is scanning channels), remove the key from the console.

**HOW TO ADJUST THE CUSHIONING SYSTEM**

The treadmill features a cushioning system that reduces the impact as you walk or run on the treadmill. To increase the firmness of the walking platform, turn the adjustment knob counterclockwise. To decrease the firmness, turn the knob clockwise. **Note: The faster you run on the treadmill, or the more you weigh, the firmer the walking platform should be.**

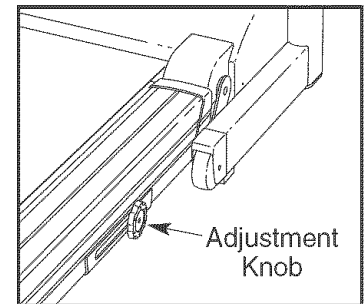

# HOW TO FOLD AND MOVE THE TREADMILL

## HOW TO FOLD THE TREADMILL FOR STORAGE

Before folding the treadmill, adjust the incline to the lowest position. If this is not done, the treadmill may be permanently damaged. Next, unplug the power cord. **CAUTION:** You must be able to safely lift 45 pounds (20 kg) to raise, lower, or move the treadmill.

1. Hold the treadmill in the locations shown at the right. **To decrease the possibility of injury, bend your legs and keep your back straight. As you raise the frame, make sure to lift with your legs rather than your back.** Raise the frame about halfway to the vertical position.
2. Hold the frame firmly with your left hand. Using your right hand, pull the latch knob to the right and hold it. Raise the treadmill until the pin on the latch knob is aligned with the hole in the left handgrip. Then, release the latch knob. **Make sure that the latch knob is fully released so the pin is fully inserted into the hole in the left handgrip.**

**To protect the floor or carpet from damage, place a mat under the treadmill. Keep the treadmill out of direct sunlight. Do not leave the treadmill in the storage position in temperatures above 85° Fahrenheit.**

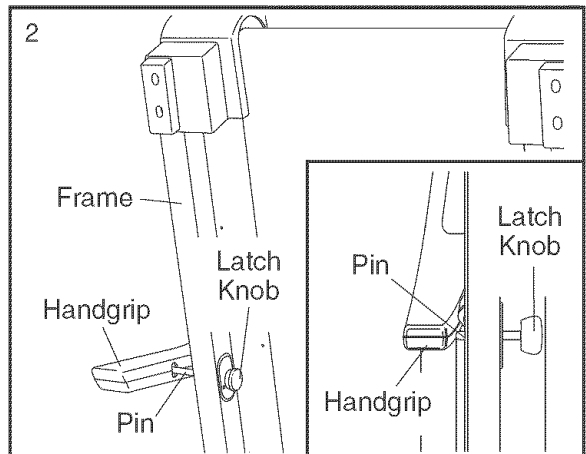
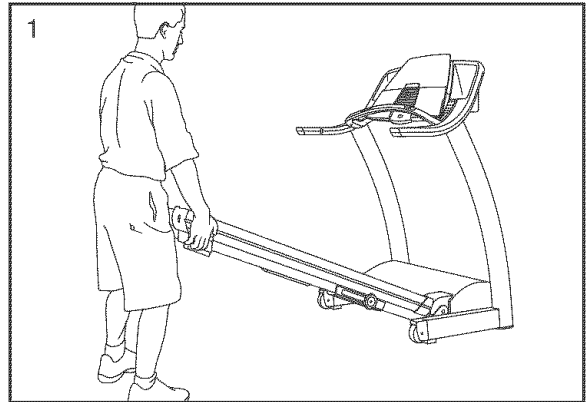

## HOW TO MOVE THE TREADMILL

Before moving the treadmill, convert the treadmill to the storage position as described above. **Make sure that the pin on the latch knob is fully inserted into the hole in the left handgrip.**

1. Hold the handgrips and place one foot against one of the wheels.
2. Tilt the treadmill back until it rolls freely on the wheels. Carefully move the treadmill to the desired location. **To reduce the risk of injury, use extreme caution while moving the treadmill. Do not attempt to move the treadmill over an uneven surface.**
3. Place one foot against a wheel, and carefully lower the treadmill until the base is in the storage position.

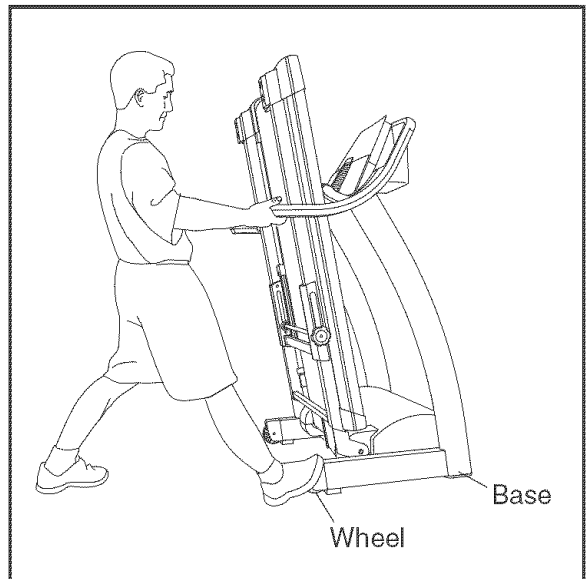

## HOW TO LOWER THE TREADMILL FOR USE

1. **See drawing 2 above.** Hold the treadmill frame firmly with your left hand. Pull the latch knob to the right. Pivot the frame down until the pin on the latch knob is below the handgrip. Then, slowly release the latch knob.
2. **See drawing 1 above.** Hold the frame firmly with both hands, and lower the frame to the floor. **To decrease the possibility of injury, bend your legs and keep your back straight.**

# TROUBLESHOOTING

Most treadmill problems can be solved by following the steps below. Find the symptom that applies, and follow the steps listed. If further assistance is needed, see the front cover of this manual.

**PROBLEM: The power does not turn on**

**SOLUTION:** a. Make sure that the power cord is plugged into a surge suppressor, and that the surge suppressor is plugged into a properly grounded outlet (see page 10). Use only a single-outlet surge suppressor that meets all of the specifications described on page 10. Important: The treadmill is not compatible with GFCI-equipped outlets.

b. After the power cord has been plugged in, make sure that the key is fully inserted into the console.

c. Check the reset/off circuit breaker located on the treadmill frame near the power cord. If the switch protrudes as shown, the circuit breaker has tripped. To reset the circuit breaker, wait for five minutes and then press the switch to the reset position.

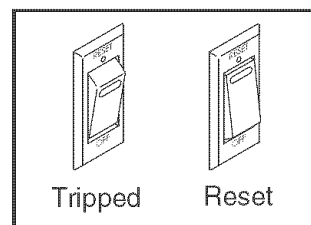

**PROBLEM: The power turns off during use**

**SOLUTION:** a. Check the reset/off circuit breaker (see the drawing above). If the circuit breaker has tripped, wait for five minutes and then press the switch to the reset position.

b. Make sure that the power cord is plugged in. If the power cord is plugged in, unplug it, wait for five minutes, and then plug it back in.

c. Remove the key from the console and then reinsert it.

d. Make sure that the reset/off circuit breaker is in the on position (see 1. d. above).

e. If the treadmill still will not run, see the front cover of this manual.

**PROBLEM: The walking belt slows when walked on**

**SOLUTION:** a. Use only a single-outlet surge suppressor that meets all of the specifications described on page 10.

b. If the walking belt is overtightened, treadmill performance may decrease and the walking belt may be permanently damaged. Remove the key and **UNPLUG THE POWER CORD**. Using the included allen wrench, turn both rear roller bolts counterclockwise 1/4 of a turn. When the walking belt is properly tightened, you should be able to lift each edge of the walking belt 3 to 4 inches off the walking platform. Be careful to keep the walking belt centered. Then, plug in the power cord, insert the key and run the treadmill for a few minutes. Repeat until the walking belt is properly tightened.

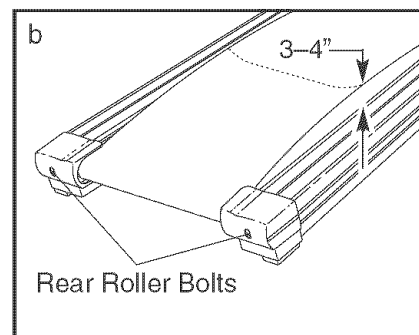

c. If the walking belt still slows when walked on, see the front cover of this manual.

**PROBLEM: The walking belt is off-center or slips when walked on**

**SOLUTION:** a. If the walking belt is off-center, first remove the key and **UNPLUG THE POWER CORD**. If the walking belt has shifted to the left, use the allen wrench to turn the left rear roller bolt clockwise 1/2 of a turn; if the walking belt has shifted to the right, turn the bolt counterclockwise 1/2 of a turn. Be careful not to overtighten the walking belt. Then, plug in the power cord, insert the key, and run the treadmill for a few minutes. Repeat until the walking belt is centered.

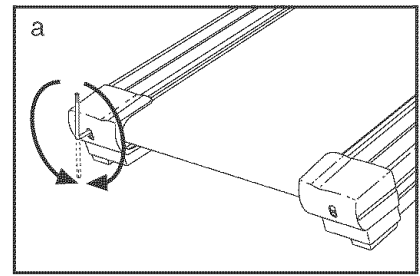

b. If the walking belt slips when walked on, first remove the key and **UNPLUG THE POWER CORD**. Using the allen wrench, turn both rear roller bolts clockwise 1/4 of a turn. When the walking belt is correctly tightened, you should be able to lift each edge of the walking belt 3 to 4 inches off the walking platform. Be careful to keep the walking belt centered. Then, plug in the power cord, insert the key, and walk on the treadmill for a few minutes. Repeat until the walking belt is properly tightened.

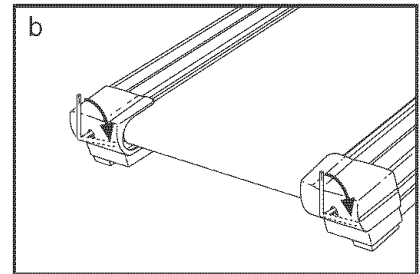

**PROBLEM: The displays of the console do not function properly**

**SOLUTION:** a. Remove the key from the console and **UNPLUG THE POWER CORD**. Next, remove the screws from the hood and carefully remove the hood. Locate the Reed Switch (17) and the Magnet (12) on the left side of the Pulley (11). Turn the Pulley until the Magnet is aligned with the Reed Switch. **Make sure that the gap between the Magnet and the Reed Switch is about 1/8"**. If necessary, loosen the indicated Screw (44), move the Reed Switch slightly, and then retighten the Screw. Re-attach the hood and run the treadmill for a few minutes to check for a correct speed reading.

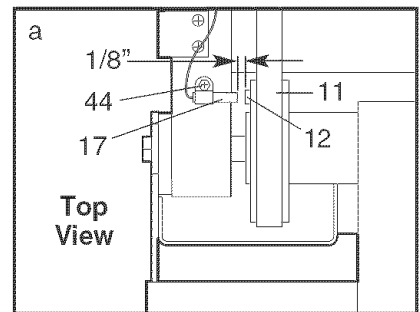

**PROBLEM: Television reception is poor**

**SOLUTION:** a. For the television to operate properly, good reception is necessary. If you are using an antenna, make sure that it is properly connected and adjusted for optimal reception. (See HOW TO CONNECT AN ANTENNA on page 9.)

b. Check for the problems listed below and follow the applicable instructions.

- Ignition (black spots or horizontal streaks that appear on a picture that flutters or drifts)—Usually this is caused by interference from automobile ignition systems, neon lamps, electric drifts, or other electric appliances. Try changing the position of the treadmill or other electric appliances to correct the problem.
- Ghosts—Ghosts are caused by the television signal following two paths—one is the direct path and the other is reflected from tall buildings, hills, or other objects. Change the direction or position of the antenna to improve reception.
- Blue Screen—If the treadmill is located in the fringe area of a television station where the signal is weak, the picture may be of poor quality or a blue screen may appear. If the signal is weak, it may be necessary to install an external antenna to improve the picture.

Note: If one of these symptoms appears when the cable from a CATV company is connected, the symptom may be caused by the local company broadcast.



# EXERCISE GUIDELINES

**⚠ WARNING:** Before beginning this or any exercise program, consult your physician. This is especially important for individuals over the age of 35 or individuals with pre-existing health problems.

The pulse sensor is not a medical device. Various factors, including the user's movement, may affect the accuracy of heart rate readings. The pulse sensor is intended only as an exercise aid in determining heart rate trends in general.

The following guidelines will help you to plan your exercise program. For more detailed exercise information, obtain a reputable book or consult your physician.

## EXERCISE INTENSITY

Whether your goal is to burn fat or to strengthen your cardiovascular system, the key to achieving the desired results is to exercise with the proper intensity. The proper intensity level can be found by using your heart rate as a guide. The chart below shows recommended heart rates for fat burning and aerobic exercise.

AEROBIC	165	155	145	140	130	125	115
MAX FAT BURN	145	138	130	125	118	110	103
FAT BURN	125	120	115	110	105	95	90
Age	20	30	40	50	60	70	80

To find the proper heart rate for you, first find your age near the bottom of the chart (ages are rounded off to the nearest ten years). Next, find the three numbers above your age. The three numbers define your "training zone." The lower two numbers are recommended heart rates for fat burning; the highest number is the recommended heart rate for aerobic exercise.

### Fat Burning

To burn fat effectively, you must exercise at a relatively low intensity level for a sustained period of time. During the first few minutes of exercise, your body uses easily accessible *carbohydrate calories* for energy. Only after the first few minutes does your body

begin to use stored *fat calories* for energy. If your goal is to burn fat, adjust the speed or incline of the treadmill until your heart rate is near the lowest number in your training zone.

For maximum fat burning, adjust the speed or incline of the treadmill until your heart rate is near the middle number in your training zone.

### Aerobic Exercise

If your goal is to strengthen your cardiovascular system, your exercise must be "aerobic." Aerobic exercise is activity that requires large amounts of oxygen for prolonged periods of time. This increases the demand on the heart to pump blood to the muscles, and on the lungs to oxygenate the blood. For aerobic exercise, adjust the speed or incline of the treadmill until your heart rate is near the highest number in your training zone.

## WORKOUT GUIDELINES

Each workout should include the following three parts:

**A Warm-up**—Start each workout with 5 to 10 minutes of stretching and light exercise. A proper warm-up increases your body temperature, heart rate and circulation in preparation for exercise.

**Training Zone Exercise**—After warming up, increase the intensity of your exercise until your pulse is in your training zone for 20 to 60 minutes. (During the first few weeks of your exercise program, do not keep your pulse in your training zone for longer than 20 minutes.) Breathe regularly and deeply as you exercise—never hold your breath.

**A Cool-down**—Finish each workout with 5 to 10 minutes of stretching to cool down. This will increase the flexibility of your muscles and will help prevent post-exercise problems.

## EXERCISE FREQUENCY

To maintain or improve your condition, complete three workouts each week, with at least one day of rest between workouts. After a few months, you may complete up to five workouts each week if desired. The key to success is to make exercise a regular and enjoyable part of your everyday life.

# PART LIST—Model No. RBTL13305.0

R0306A

To locate the parts listed below, see the EXPLODED DRAWING attached in the center of this manual.

Key No.	Qty.	Description	Key No.	Qty.	Description
1	2	Foot Rail	51	1	Hood Cover
2	1	Left Outside Housing	52	2	Roller Adj. Washer
3	1	Left Handgrip, Top	53	2	Rear Roller Adjustment Bolt
4	4	Isolator	54	1	Left Rear Endcap
5	1	Latch Housing Cover	55	1	Frame
6	1	Platform	56	1	Allen Wrench
7	2	Walking Platform Screw	57	2	Rear Platform Screw
8	1	Walking Belt	58	1	Rear Roller
9	2	Frame Pivot Bolt	59	4	Foot Screw
10	4	Frame Pivot Washer	60	2	Cable Nut
11	1	Front Wheel/Pulley	61	1	Pulse Bar
12	1	Magnet	62	4	Spring Nut
13	9	Front Roller Nut/Front Wheel Nut	63	1	Idler Arm
14	2	Spacer Insert	64	1	Idler Spring
15	2	Frame Pivot Spacer	65	1	Upright/Base
16	1	Reed Switch Clip	66	4	Belt Guide Screw
17	1	Reed Switch	67	1	Console Frame
18	1	Lift Frame	68	1	Latch Housing
19	2	Foot Rail Insert	69	4	Console Washer
20	2	Gear Rack	70	4	Spring Washer
21	14	Foot Rail Screw	71	1	Console Wire Harness
22	1	Motor Belt	72	1	iFIT.com Wire
23	4	Gear Rack Screw	73	2	Incline Pivot Bolt
24	1	Drive Motor	74	1	Flywheel
25	1	Transformer	75	2	Spring
26	4	Cushion Adj. Housing Screw	76	2	Spring Pad Screw
27	4	Hood Bracket	77	2	Front Wheel
28	1	Ground Wire	78	2	Wheel Bolt
29	4	Star Washer	79	1	Pulley Nut
30	1	Right Rear Endcap	80	1	Console
31	1	Lift Motor Bolt	81	1	Console Base
32	2	Motor Bolt	82	1	Fan
33	2	Cushion Plate	83	2	Spring Pad
34	1	Left Inside Housing	84	4	Belly Pan Screw
35	1	Right Inside Housing	85	1	Upright Wire Harness
36	1	Right Outside Housing	86	1	Shock
37	1	Controller	87	2	Spring Plate Spacer
38	1	Controller Bracket	88	2	Upright Endcap
39	1	Motor Hood	89	1	Filter Wire
40	48	3/4" Screw	90	1	Latch Warning Decal
41	1	Motor Belly Pan	91	1	Incline Motor
42	2	Belt Guide	92	1	Motor Controller Wire
43	6	3/4" Tek Screw	93	2	Fan Screw
44	12	Electronics Screw	94	2	Tie Holder Screw
45	1	Left Front Endcap	95	2	Tie Holder
46	1	Right Front Endcap	96	1	Tie
47	1	Ground Screw	97	5	8" Cable Tie
48	2	Rear Foot	98	2	Base Pad
49	1	Console Ground Wire	99	1	Idler Arm Bolt
50	1	Fan Housing	100	1	Upright TV Cable

Key No.	Qty.	Description	Key No.	Qty.	Description
101	1	Pulse Wire	126	1	Right Handgrip, Top
102	1	Power Cord Assembly	127	1	Motor Isolator Plate
103	1	TV Console	128	2	Cushion Adj. Gear
104	2	Warning Decal	129	2	Cushion Adj. Wheel
105	2	Spring Plate	130	1	Cushion Adj. Knob
106	1	Left Handgrip, Bottom	131	1	Cushion Adj. Screw
107	1	Warning Decal, Pulse Bar	132	2	1/2" Screw
108	2	Rear Roller Star Washer	133	4	1" Console Bolt
109	1	Pulley Washer	134	4	Pulse Bar Screw
110	1	Idle Pulley	135	1	Access Door
111	1	Pulley Spacer	136	1	Key/Clip
112	2	Outlet Bracket Star Washer	137	2	Wheel Housing
113	1	Static Decal	138	1	Right Handgrip, Bottom
114	2	1/2" Tek Screw	#	1	8" Blue Wire, 2 F
115	1	Idle Pulley Bolt	#	1	4" Blue Wire, M/F
116	4	Spring Washer	#	1	4" Blue Wire, 2 F
117	1	Console Back	#	1	Blue Wire, M/F
118	1	Latch Assembly	#	1	12" Green Wire, F/Ring
119	4	Spring Bolt	#	1	8" Green Wire, 2 Ring
120	2	Cushion Adj. Pin	#	1	14" White Wire, 2 F
121	2	Motor Bushing	#	1	4" Black Wire, 2 F
122	1	Idle Arm Nylon Washer	#	1	User's Manual
123	1	Cushion Adj. Rod			
124	1	Incline Bracket			
125	1	Incline Motor Bolt, Bottom			

# These parts are not illustrated  
Specifications are subject to change without notice.

---

## ORDERING REPLACEMENT PARTS

To order replacement parts, see the front cover of this manual. When ordering parts, please be prepared to give the following information:

- the MODEL NUMBER OF THE PRODUCT (RBTL13305.0)
- the NAME OF THE PRODUCT (REEBOK VISTA treadmill)
- the SERIAL NUMBER of the product (see the front cover of this manual)
- the KEY NUMBER and DESCRIPTION of the part(s) (see the PART LIST on pages 26 and 27)

# EXPLODED DRAWING—Model No. RBTL13305.0

R0306A

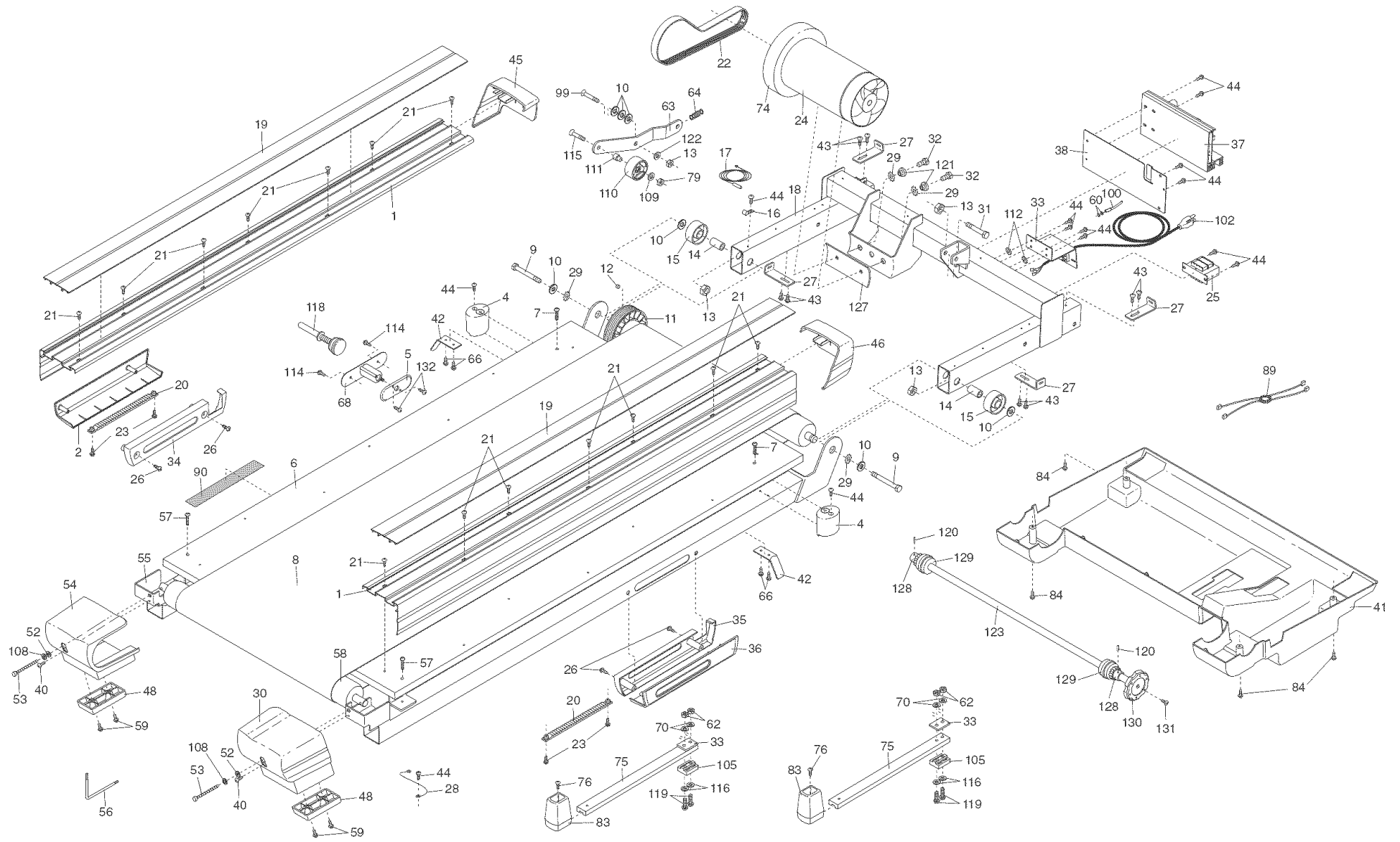

# EXPLODED DRAWING—Model No. RBTL13305.0

R0306A

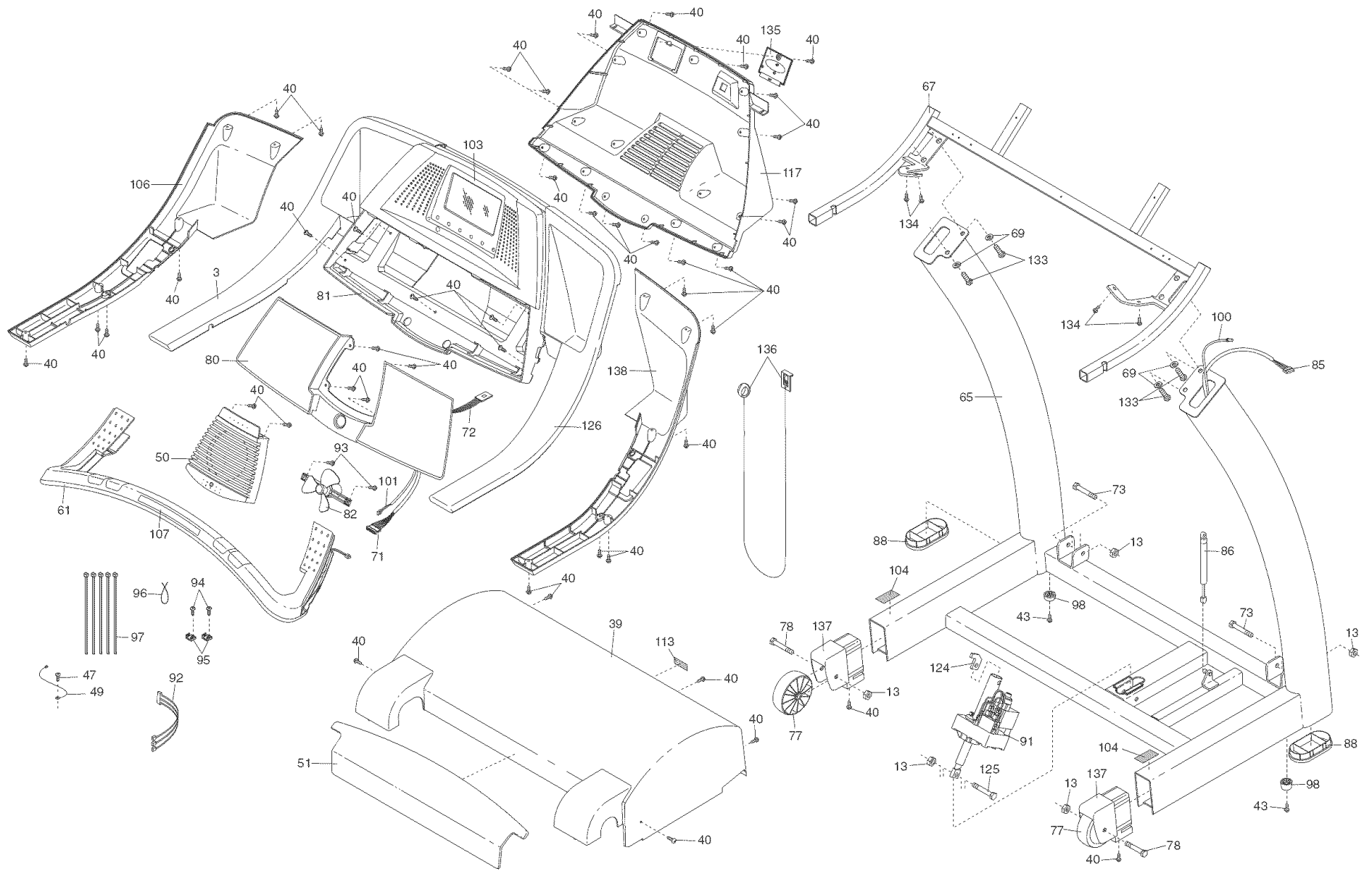

## LIMITED WARRANTY

**WHAT IS COVERED**—The entire REEBOK VISTA (“Product”) is warranted to be free of all defects in material and workmanship.

**WHO IS COVERED**—The original purchaser or any person receiving the Product as a gift from the original purchaser.

**HOW LONG IS IT COVERED**—ICON Health & Fitness, Inc. (“ICON”), warrants the drive motor for twenty years after the date of purchase. Parts and labor are covered for one year after the date of purchase.

**WHAT WE DO TO CORRECT COVERED DEFECTS**—We will ship to you, without charge, any replacement part or component, providing the repairs are authorized by ICON first and are performed by an ICON trained and authorized service provider, or, at our option, we will replace the Product.

**WHAT IS NOT COVERED**—Any failures or damage caused by unauthorized service, misuse, accident, negligence, improper assembly or installation, alterations, modifications without our written authorization or by failure on your part to use, operate, and maintain as set out in your User’s Manual (“Manual”).

**WHAT YOU MUST DO**—Always retain proof of purchase, such as your bill of sale; store, operate, and maintain the Product as specified in the Manual; notify our Customer Service Department of any defect within 10 days after discovery of the defect; as instructed, return any defected part for replacement or, if necessary, the entire product, for repair.

**USER’S MANUAL**—It is VERY IMPORTANT THAT YOU READ THE MANUAL before operating the Product. Remember to do the periodic maintenance requirements specified in the Manual to assure proper operation and your continued satisfaction.

**HOW TO GET PARTS AND SERVICE**—Simply call our Customer Service Department at 1-877-994-4999 and tell them your name and address and the serial number of your Product. They will tell you how to get a part replaced, or if necessary, arrange for service where your Product is located or advise you how to ship the Product for service. Before shipping, always obtain a Return Authorization Number (RA No.) from our Customer Service Department; securely pack your Product (save the original shipping carton if possible); put the RA No. on the outside of the carton and insure the product. Include a letter explaining the product or problem and a copy of your proof of purchase if you believe the service is covered by warranty.

ICON is not responsible or liable for indirect, special or consequential damages arising out of or in connection with the use or performance of the product or damages with respect to any economic loss, loss of property, loss of revenues or profits, loss of enjoyment or use, costs of removal, installation or other consequential damages of whatsoever nature. Some states do not allow the exclusion or limitation of incidental or consequential damages. Accordingly, the above limitation may not apply to you.

The warranty extended hereunder is in lieu of any and all other warranties and any implied warranties of merchantability or fitness for a particular purpose is limited in its scope and duration to the terms set forth herein. Some states do not allow limitations on how long an implied warranty lasts. Accordingly, the above limitation may not apply to you.

No one is authorized to change, modify or extend the terms of this limited warranty.

This warranty gives you specific legal rights and you may have other rights which vary from state to state.

**ICON HEALTH & FITNESS, INC., 1500 S. 1000 W., LOGAN, UT 84321-9813**