

User Guide

(provisional)

SASL™ (Signal Acquisition & Source Location unit)

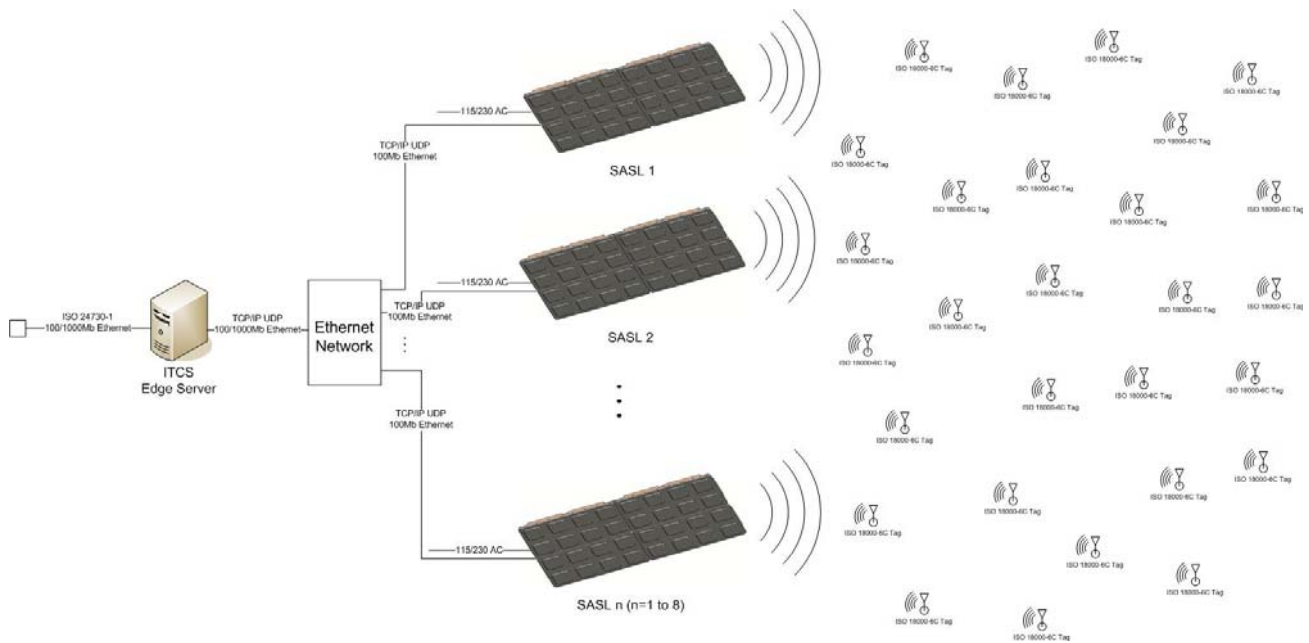

RF Controls Intelligent Tracking and Control System (ITCS™)

Introduction

This **SASL™ User Guide** provides the basic information needed to install and set up an individual **SASL** antenna unit. This guide is not intended to provide instructions for installing, configuring and calibrating the RF Controls Intelligent Tracking and Control System (**ITCS™**). Detailed instructions are provided in the **System Integrator Installation Manual** and **Programmer's Reference Guide**.

INTENDED AUDIENCE

This guide is intended for those who will install and set up the RF Controls **SASL** (Signal Acquisition and Source Location) unit. Before attempting to install, configure and operate this product, you should be familiar with the following:

- Windows based software installation and operation
- Device communication parameters including Ethernet and serial communications
- RFID reader configuration including antenna placement and RF Parameters
- Electrical and RF safety procedures.

CONTENTS

1. SASL overview
2. Installation
3. Software
4. Specifications
5. Safety instructions

FCC NOTICE

This device complies with part 15 of the FCC Rules. Operation is subject to the following two conditions: (1) This device may not cause harmful interference, and (2) this device must accept any interference received, including interference that may cause undesired operation.

CONTACT INFORMATION

RF Controls LLC
1141 S 7th Street
St. Louis
MO 63104-3623
USA

Phone: +1 314 5716200
Fax: +1 314 832 0029
Web site: <http://www.rfctrls.com>

SASL OVERVIEW

SASL is a multi-protocol, multi-regional Radio Frequency Signal Acquisition & Source Location unit, which is used to Identify and locate RFID tags operating in the UHF 860 – 960 MHz frequency band. A number of **SASL** units may be used together with an **ITCS** 'Edge Server' to form an Intelligent Tracking and Control System (**ITCS**).



Figure 1
SASL (Signal Acquisition and Source Location unit)

SASL comprises an embedded multi-protocol, multi-regional RFID reader/writer transceiver connected to the patented steerable phased array antenna system. **SASL** is designed to operate from AC mains power in the range of 90 to 260 Volts AC 50/60Hz and communicates with a host computer using standard Ethernet TCP/IP and UDP protocol. Figure 2 shows the rear view of the **SASL** mounted on a support frame using “Unistrut®” fasteners.



Figure 2:
SASL Rear View

INDICATOR LIGHTS

There are four lights on the back of the **SASL** located on the **Sirit** RFID reader.

The indicator lights on the Sirit RFID reader are:

- **Sense** – Indicates that the reader has detected a tag in the RF field
- **Transmit** – indicates that the reader/writer transmitter is operating (RF on)
- **Fault** – Indicates that there is a fault
- **Power** – Indicates that power is applied to the reader

Note that when the Sirit reader is performing power on auto-test, the indicator lights will flash momentarily.



Figure 3
Sirit RFID Reader Indicator Lights.

Installation

MECHANICAL INSTALLATION

The **SASL** is provided in its standard configuration with a mounting bracket for installation in a landscape orientation. An optional portrait mounting bracket is available if under special circumstances an installation configuration requires the **SASL** to be installed in portrait orientation. Contact a member of our technical support team for more information.

The **SASL** unit weighs 75 lbs (34 kg), so it is important to ensure that the structure, to which the **SASL** is to be attached, is of sufficient strength.

The **SASL** may be ceiling mounted, wall mounted or attached to a suitable stand. When ceiling mounted, a separate safety cable must be secured to a ceiling fixture and to one of the eyes the **SASL** mounting bracket.

The **SASL** mounting bracket incorporates a mounting tube which is designed to be attached to industry standard “**UNISTRUT**®” industrial framing systems. (See: www.unistrut.com for more information). Figure 2 shows the **SASL** mounted on a frame.

When mounting the **SASL** as a stand-alone unit, make sure that it is mounted the correct way up as indicated by the arrow on the back panel. If the **SASL** is one of several and is part of an **ITCS** network, then orientate each **SASL** according to the **ITCS** system installation drawings. If in doubt contact a member of our technical support team.

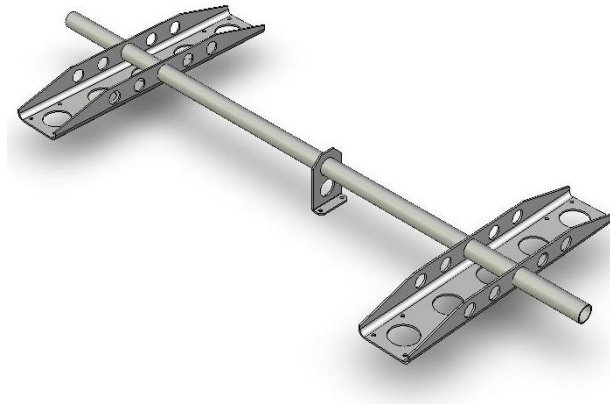

Figure 4
Mounting bracket.

SAFETY WARNING

The **SASL** weighs 75lbs (34kg) and should only be installed using suitable safety and lifting equipment. Ensure that the wall fixings or mounting hardware is suitably rated.

ELECTRICAL INSTALLATION

Electrical installation requires the connection of two plugs.

AC Mains Input

AC mains input is provided on an IEC connector on the power supply module as shown in figure 5. Connect the provided IEC mains cord to the power supply and plug it in to a suitable mains outlet. Note that the mains outlet must be located in close proximity to the **SASL** and must be accessible to enable easy disconnection of the mains supply to the **SASL** in case of emergency or when servicing.

Ethernet

The Ethernet LAN connection uses the industry standard RJ-45 connector. A suitable Ethernet cable fitted with an RJ-45 plug is connected to the **SASL** RAID processor box as shown in figure 5. The **SASL** is factory programmed with a fixed IP address which is shown on the label adjacent to the Ethernet connector.



Figure 5
Power and Ethernet Connections

WARNING

The interconnect wiring and cables on the rear of the SASL are factory installed and are not intended to be field serviceable. The RF cables are specially tuned. Any tampering or modification of these cables or connections will invalidate type approval and may seriously compromise the device performance. Note that the connectors are fitted with tamper evident seals.

MULTIPLE SASL UNITS CONFIGURED AS AN ITCS

Two or more **SASL** units may be connected via an Ethernet network to an **ITCS** Edge Server to form an Intelligent Tracking and Control System. The diagram in figure 6 illustrates the basic system architecture. The RF Controls **System Integration Manual** provides details on how to install, configure and calibrate an **ITCS**. The **Programmers Reference Guide** provides details of the Application Program Interface (API) used by the **ITCS**.

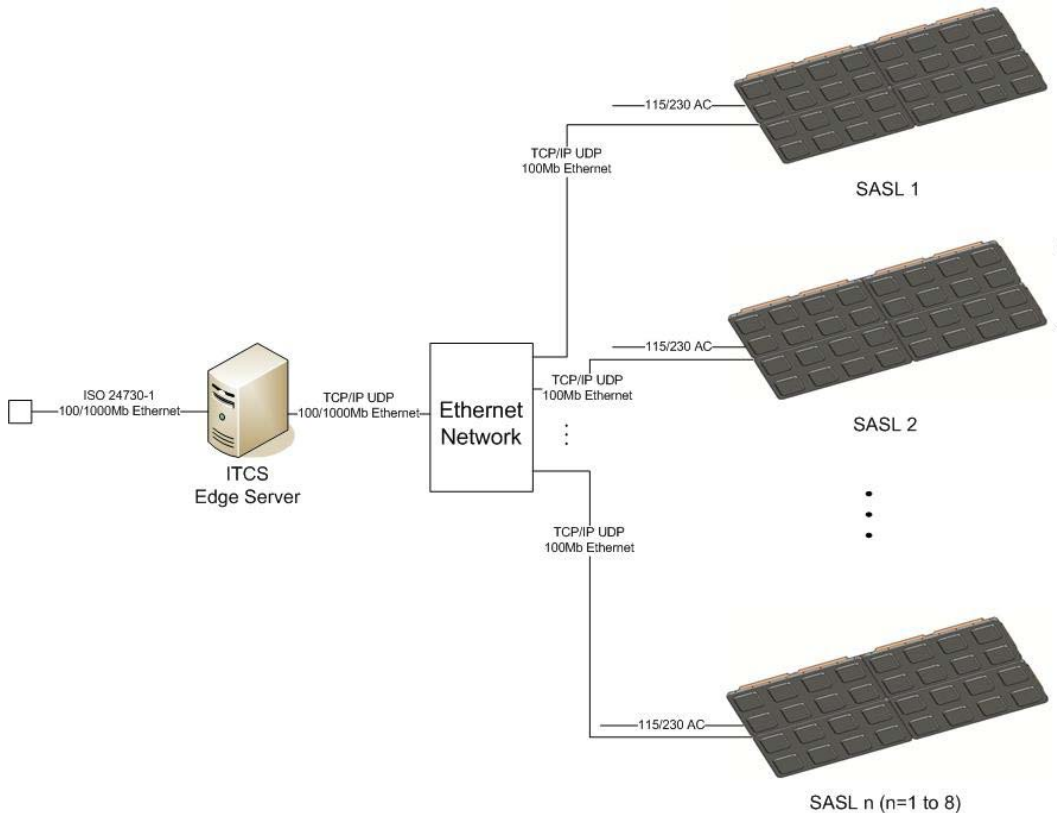

Figure 6
Intelligent Tracking and Control System comprising a number of SASL units connected via an Ethernet Network to an ITCS Edge Server

NON IONIZING RADIATION

This unit incorporates a Radio Frequency Transmitter and should therefore be installed and operated so as to avoid exposure of any persons to unsafe emissions. The FCC requires that any antenna, which includes the **SASL**, be mounted so that a separation distance of at least 20cm is provided from all persons. See **FCC Radiation Exposure Statement** in the Safety Instructions section of this guide.

Software

The **SASL** is provided with a basic test program on a CD, to run on a Microsoft™ Windows® equipped Personal Computer. The program enables you to carry out a number of basic tests:

- Command the **SASL** to transmit
- Adjust the RF output power of the **SASL** as a percentage of maximum power. (Note: the maximum output power is factory set to the maximum RF output power allowed for the particular country of destination).
- Identify a tag by its UII number (EPC code in the case of EPC UHF Gen 2)
- Display the Received Signal Strength of each tag
- Display the Phi Φ and Theta θ values of the **SASL** beam direction.

The installation software should automatically install when the CD is inserted into the PC. If for any reason it does not auto run, then browse for the **setup.exe** file on the installation CD and run it. Once the program has been successfully installed it may be opened.

Figure 7 shows the basic test program control panel screen.

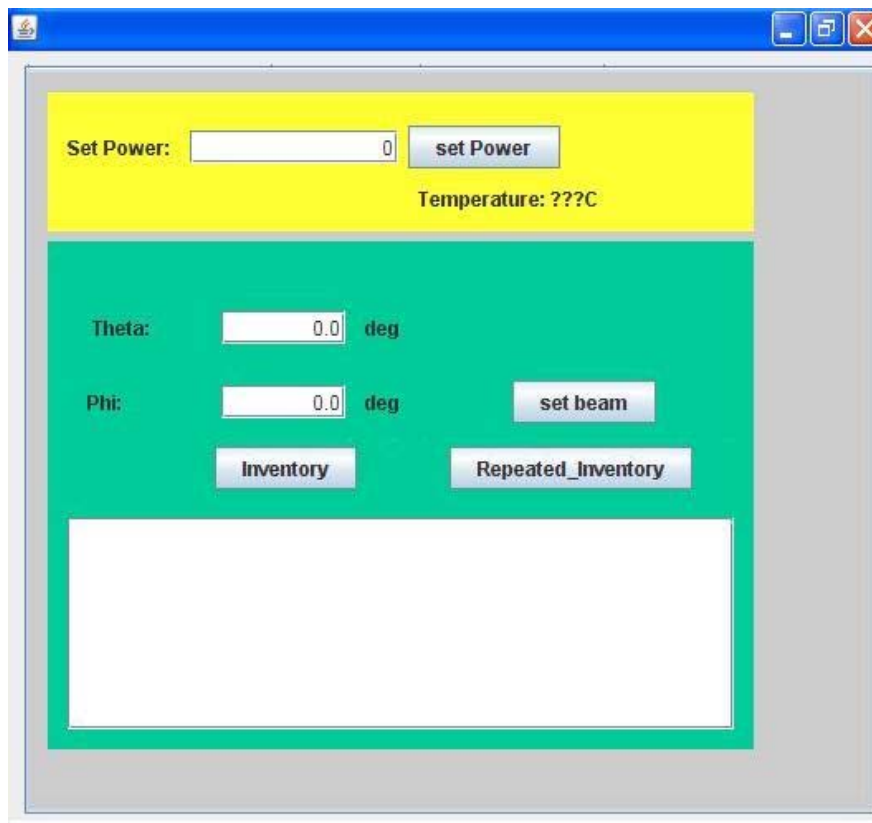

Figure 7
Test Program Control Panel Screen

USING THE TEST PROGRAM

Set RF Output Power

Enter the desired RF output power as a percentage of the maximum power into the Set Power box. Click the **set Power** button. (Note: the actual maximum Radiated RF Power is factory set to comply with the radio regulations in the country of use. In the USA and Canada this is 4 Watts EIRP).

Set Beam

The beam direction may be pointed to any desired direction within ± 30 degrees of a line perpendicular to the centre of the **SASL** antenna panel. When looking in the direction of the beam (as if through the **SASL**), and with the **SASL** orientated with the arrow upwards, Phi +ve angles are up, -ve angles are down. Theta +ve is left and -ve is right. Enter the steering angles Theta and Phi in the respective boxes and click **set beam**.

Read Tags

Click the **Inventory** button. Tag UID (EPC code) followed by the Received Signal Strength in dBm will be shown in the window for each tag identified. If there is more than one tag, then each tag identified will be shown on a separate line. Click the **Repeated_Inventory** button to repeatedly query for tags present in the **SASL** beam. This function is useful for identifying tags that are moving.

APPLICATION INTERFACE

The **SASL** uses an International Standard, Application Program Interface (API) as defined in ISO/IEC 24730. Further details of the API and commands are contained in the **Programmer's Reference Guide**.

Specifications

General	
Frequency	UHF band: 860 – 960 MHz *Note
RF Radiated Output Power	Adjustable from 0.1 to 4 Watts EIRP
Regulatory Compliance	FCC, CFR47 Part 15.247
Reading/writing Protocols	ISO18000-6C / EPC UHF Gen 2
FCC ID	EM 4122 (TTO)
Application Interface	WFQITCSA100 ISO/IEC 24730
Environmental	
Operating Temperature	0 to 60 deg C
Storage Temperature	-40 to 85 deg C
Relative Humidity	5 to 95% non-condensing
Dimensions	64in x 32in x 6in (162.5 x 81.25 x 15.24 cm)
Weight	75 lbs (34 kg)
Ethernet LAN	
Connector	RJ-45
Ethernet	10/100 BaseT
Indicators	Yellow – link operational Green – network traffic detected
Signals	Pin 1 TXD+ Pin 2 TXD - Pin 3 RXD+ Pin 4 NC Pin 5 NC Pin 6 RXD - Pin 7 NC Pin 8 NC
Power Supply	
Input Connector	IEC/EN 60320
Voltage	90 – 265 Volts AC
Frequency	48 – 62 Hz
Consumption	90VA
Antenna	
Gain	Nominally 7.6dBi (depends on transmit frequency)
Polarization	Circular

Note: The SASL uses the Sirit INfinity 510 RFID reader which is type approved for use in the USA, Canada, Europe and many other countries. The specific operating frequency/s and transmit mode will be factory set at time of shipping, to suit the country of installation and use.

Safety Instructions

This unit emits Radio Frequency non-ionizing radiation. The installer must ensure that the antenna is located or pointed such that it does not create an RF field in excess of that permitted by the Health and Safety Regulations applicable to the country of installation.

FCC Radiation Exposure Statement

The antenna used on this equipment must be installed to provide a separation distance of at least 20cm from all persons and must not be co-located or operated in conjunction with another antenna or transmitter.

FCC Part 15 Notice

This device complies with part 15 of the FCC Rules. Operation is subject to the following two conditions: (1) This device may not cause harmful interference, and (2) this device must accept any interference received, including interference that may cause undesired operation.

Power Disconnect Device

The plug on the power supply cord is intended to be the power disconnect device. The power source (socket or outlet) shall be located near the equipment and shall be easily accessible.

This product is protected by one or more US and International Patents pending.

The “RF Controls” logo, and the words “RF Controls, Identify, Locate, Track”, “ITCS” and “SASL” are registered Trade Marks of RF Controls LLC.

RF Controls LLC
1141 S 7th Street
St. Louis
MO 63104-3623
USA

Phone: +1 314 571 6200
Fax: +1 314 832 0029
Web site: <http://www.rfctrls.com>