

Complete 2.4 GHz RF Transceiver Module with Built-In RFDP8 Application Protocol

RFD21743 RFDANT FCC APPROVED

RF DIGITAL
WIRELESS
RADIO INSIDE ANTENNA
RFDANT

HIGH GAIN **RFD21743** **ZERO LOSS**

RFDANT

No RF knowledge required Long Range

EXCELLENT ANTENNA PATTERN

NO RF CABLE REQUIRED

ULP Patents Pending

WWW.RFDIGITAL.COM

Applications

- Active RFID
- Long Range RFID
- Remote Control
- Light Controls
- Home Automation
- Alarm Security
- Keyless Entry
- Perimeter Monitoring
- PC Keyboard Security
- Wireless Keyboard
- Wireless Mouse
- TV Remote
- Home Stereo Remote
- Asset Tracking
- Wireless PTT
- Remote Switches
- Remote Terminals
- Wireless RS232 DB9
- Wireless RS485
- Temperature Control
- HV/AC
- Meter Reading
- Data Acquisition
- Inventory Control
- Keyfob Remotes
- Industrial Controls
- Vending Machines

RFD21743 is a complete, **READY-TO-USE** wireless solution with its built-in user application interface (RFDP8). Includes RFID, ESN, Logic Switch Transmitter / Receiver, 9600,N,8,1 Serial UART and many easy-to-use addressable network modes. No development required at all, no RF layout, no code writing, all features are built-in. Be up and running with a full wireless solution in minutes.

RFD21743 RFDANT Features

- Runs on a single coin cell for years.
- WiFi interference tolerant.
- Bluetooth interference tolerant.
- Zigbee interference tolerant.
- Very low cost.
- No external parts required.
- No RF layout required.
- Easy and ready-to-use, hand-held, eval and application boards available.
- Fully contained, truly a finished, ready to use module.
- FCC Certified.
- Typical range outdoor; 300 feet (100 meters), indoor 100 feet (33 meters).
- Worldwide 2.4GHz ISM band operation.
- User configurable without need for any programming.
- 2uA Ultra low power modes.
- Only 14mA current consumption at 0dbm RF power output.
- Only 17mA current consumption at -94 dBm receive sensitivity.
- 16 bit CRC data accuracy verification built-in.
- 32 bit unique factory ESN in every module (4 billion combination security).
- Flexible network modes, including broadcast and individual addressing.
- Optional version available for use with external antenna (RFD21735).
- Switch on/off, logic, remote-control without the need for an external controller.
- Switch nodes individually addressable without the need for an external controller.
- Wide supply range +1.9V to +3.6V.
- Built-in, high performance internal antenna.
- Peer to Peer (Ad-Hoc) networks and configurations.
- Point to Multi-Point networks and configurations.
- Multi-Point to Multi-Point networks and configurations.
- Selective addressing of any module by using factory built-in ESN.
- Fast-turn-around, minimal latency (20 millisecond).
- Patent pending RFDP8 interference tolerant protocol.
- Full application protocol runs transparent to the user.
- Easy to use, simple to design in.
- Stores up to 60 ESNs (Electronic Serial Numbers) for network modes.
- Many to one data modes ideal for multi-point data acquisition.
- Unlimited number of module nodes can communicate to each other.

Custom Modules

RF Digital's RFDP8 application firmware loaded into the RFD21743 RFDANT module can be customized to fit application specific user requirements.

RF Digital can design and manufacture fully custom modules to fit specific customer requirements.

If you do not find what you're looking for, feel free to contact RF Digital with your requirements.

Eval Kits

See below for **READY-TO-USE** Eval boards.

RFDP8 Application Protocol • Mode Selector Chart

RFDP8 8-Mode Chart for RFD21733 / RFD21735

© RF Digital Corp. 01.27.09 8:34 PM

Mode	Description	Mode Select Inputs						Learn / Status	
		2	1	0					
0	Active RFID Transmitter	0	0	0	IN 3	IN 2	IN 1	TX LED	
1	3 Input Switch Logic Transmitter	0	0	1	IN 3	IN 2	IN 1	TX LED	
2	Serial UART Transceiver, 9600, N, 8, 1	0	1	0	TXD IN	RXD OUT	LOGIC I/O	X	
3	Serial UART Transceiver, 9600, N, 8, 1	0	1	1	TXD IN	RXD OUT	LOGIC I/O	ESN LEARN	Network
4	3 Output Switch Logic Receiver - 500ms	1	0	0	OUT 3	OUT 2	OUT 1	X	
5	3 Output Switch Logic Receiver - 500ms	1	0	1	OUT 3	OUT 2	OUT 1	ESN LEARN	Network
6	3 Output Switch Logic Receiver - 20ms	1	1	0	OUT 3	OUT 2	OUT 1	X	
7	3 Output Switch Logic Receiver - 20ms	1	1	1	OUT 3	OUT 2	OUT 1	ESN LEARN	Network
RFD21733 / RFD21735 Pin Number:		3	17	16	7	6	5	4	

RFD21743 System Configuration Examples

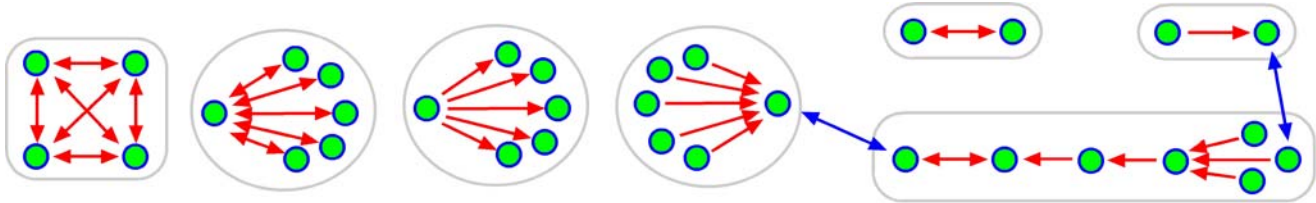

● RFD21733 / RFD21735 Unlimited number of nodes and configurations with and without network mode.

RFD21743 Application Configuration Examples

<p>Bidirectional serial transceiver normally sits in receive mode, receiving and outputting serial bytes out of the RXD pin, as they come in. When user sends data into TXD pin it automatically switches to transmit.</p>	<p>MODE 2</p> <p>SERIAL TRANSCEIVER</p>	<p>Bidirectional serial transceiver normally sits in receive mode, receiving and outputting serial bytes out of the RXD pin, as they come in. When user sends data into TXD pin it automatically switches to transmit.</p>
<p>Bidirectional serial transceiver normally sits in receive mode, receiving and outputting serial bytes out of the RXD pin, as they come in. When user sends data into TXD pin it automatically switches to transmit. The receiver will only respond to transmitters if it has learned their ESNs.</p>	<p>MODE 3</p> <p>SERIAL NETWORK TRANSCEIVER</p>	<p>Bidirectional serial transceiver normally sits in receive mode, receiving and outputting serial bytes out of the RXD pin, as they come in. When user sends data into TXD pin it automatically switches to transmit. The receiver will only respond to a transmitters if it has learned their ESNs.</p>
<p>Bi-directional serial transceiver normally sits in receive mode, receiving and outputting serial bytes out of the RXD pin, as they come in. When user sends data into TXD pin it automatically switches to transmit.</p>	<p>MODE 2</p> <p>SERIAL TRANSCEIVER</p>	<p>Bi-directional serial transceiver normally sits in receive mode, receiving and outputting serial bytes out of the RXD pin, as they come in. When user sends data into TXD pin it automatically switches to transmit. The receiver will only respond to transmitters if it has learned their ESNs.</p>
<p>In this mode, simply apply 1.9 to 3.6 VDC (typically 3V), and the RFD21733 and it will automatically transmit once every 2 seconds as an RFID transmitter. With every transmission it also sends it's unique 32 BIT ESN (Electronic Serial Number).</p>	<p>MODE 0</p> <p>ACTIVE RFID TRANSMITTER</p>	<p>Once every 2 seconds, depending on the configured mode, OUT1 will output a level high signal for a duration of 20 or 500 milliseconds. The idle state is low.</p>

RFD21743 Application Configuration Examples

In this mode, simply apply 1.9 to 3.6 VDC (typically 3V), and the RFD21733 and it will automatically transmit once every 2 seconds as an RFID transmitter. With every transmission it also sends it's unique 32 BIT ESN (Electronic Serial Number).

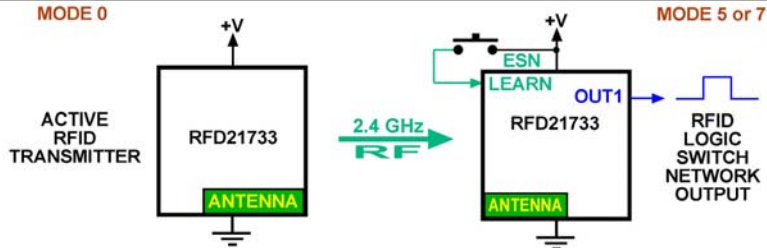

Once every 2 seconds, depending on the configured mode, OUT1 will output a level high signal for a duration of 20 or 500 milliseconds. The idle state is low. The receiver will only respond to transmitters if it has learned their ESNs.

In this mode, simply apply 1.9 to 3.6 VDC (typically 3V), and the RFD21733 and it will automatically transmit once every 2 seconds as an RFID transmitter. With every transmission it also sends it's unique 32 BIT ESN (Electronic Serial Number).

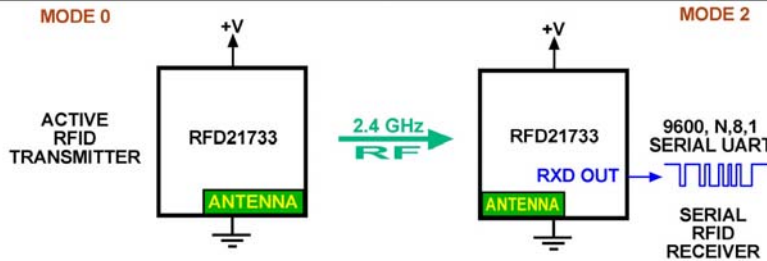

Once every 2 seconds, the RXD pin will output 5 bytes. Byte 1 will have bit 4 and bit 1 set, and bytes 2-5 are the 32 bit ESN of the RFID transmitter.

In this mode, simply apply 1.9 to 3.6 VDC (typically 3V), and the RFD21733 and it will automatically transmit once every 2 seconds as an RFID transmitter. With every transmission it also sends it's unique 32 BIT ESN (Electronic Serial Number).

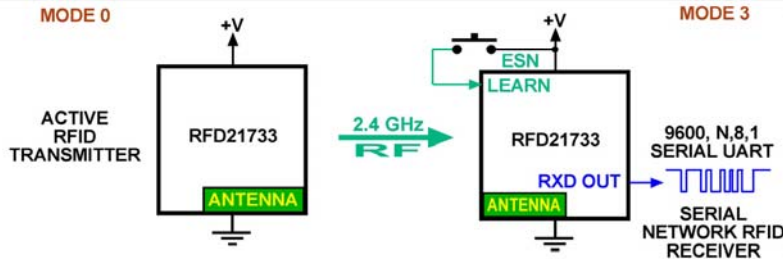

Once every 2 seconds, the RXD pin will output 5 bytes. Byte 1 will have bit 4 and bit 1 set, and bytes 2-5 are the 32 bit ESN of the RFID transmitter. The receiver will only respond to transmitters if it has learned their ESNs.

The RFD21733 stays in (2 uA) deep sleep, until any combination of the 3 buttons are pressed, then it will transmit the state of all 3 inputs. With every transmission it also sends it's unique 32 BIT ESN (Electronic Serial Number).

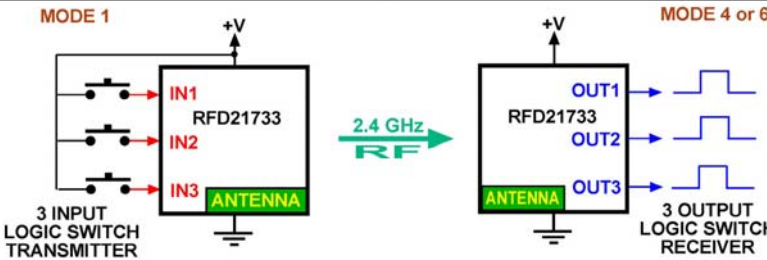

OUT1, OUT2 or OUT3 (follow) output any transmission received by the transmitter switch states IN1, IN2 or IN3. Depending on the configured mode there is a 20 or 500 millisecond hang time.

The RFD21733 stays in (2 uA) deep sleep, until any combination of the 3 buttons are pressed, then it will transmit the state of all 3 inputs. With every transmission it also sends it's unique 32 BIT ESN (Electronic Serial Number).

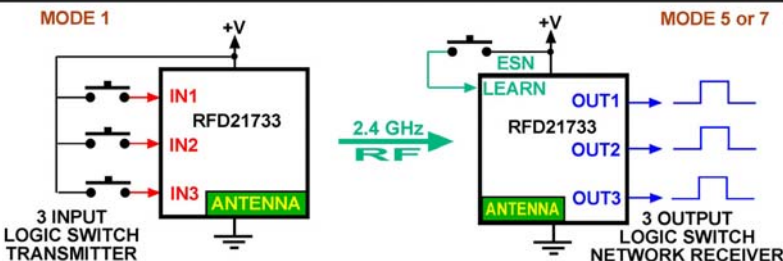

OUT1, OUT2 or OUT3 (follow) output any transmission received by the transmitter switch states IN1, IN2 or IN3. Depending on the configured mode there is a 20 or 500 millisecond hang time. The receiver will only respond to transmitters if it has learned their ESNs.

RFD21743 Application Configuration Examples

The RFD21733 stays in (2 uA) deep sleep, until any combination of the 3 buttons are pressed, then it will transmit the state of all 3 inputs. With every transmission it also sends it's unique 32 BIT ESN (Electronic Serial Number).

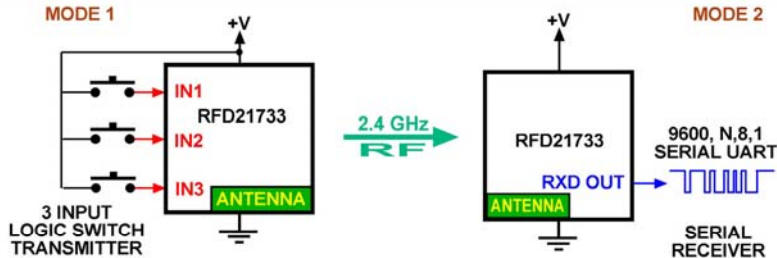

When a transmission is received. The RXD pin outputs 5 bytes. Byte 1 (bit 4,5,6) are the transmitter input states IN1, IN2, IN3. Bytes 2-5 are the 32 bit ESN of the switch transmitter.

The RFD21733 stays in (2 uA) deep sleep, until any combination of the 3 buttons are pressed, then it will transmit the state of all 3 inputs. With every transmission it also sends it's unique 32 BIT ESN (Electronic Serial Number).

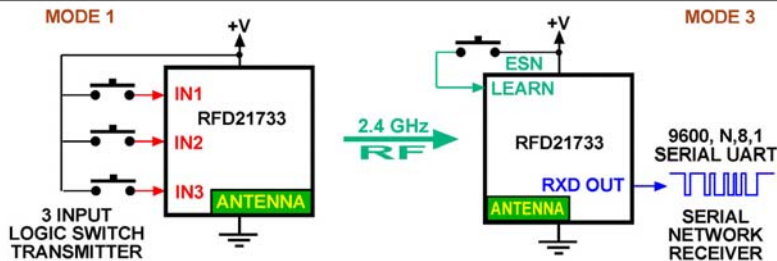

When a transmission is received. The RXD pin outputs 5 bytes. Byte 1 (bit 4,5,6) are the transmitter input states IN1, IN2, IN3. Bytes 2-5 are the 32 bit ESN of the switch transmitter. The receiver will only respond to transmitters if it has learned their ESNs.

Apply a single byte into the TXD pin to control the states of the switch receiver. Bit position 4,5,6 represent OUT1, OUT2, OUT3 on the receiver, all other bits must be zero. The receivers outputs states can not be updated any faster then once every 20 milliseconds.

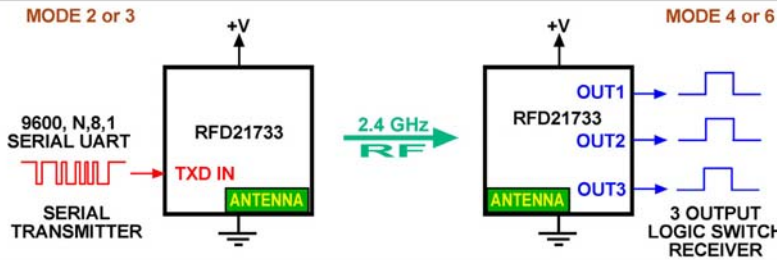

When a byte is received by the serial transmitter, OUT1, OUT2, OUT3, follow the states in bit position 4,5,6. Depending on the configured mode there is a 20 or 500 millisecond hang time.

Apply a single byte into the TXD pin to control the states of the switch receiver. Bit position 4,5,6 represent OUT1, OUT2, OUT3 on the receiver, all other bits must be zero. After sending the single byte, wait at least 20 milliseconds before sending again.

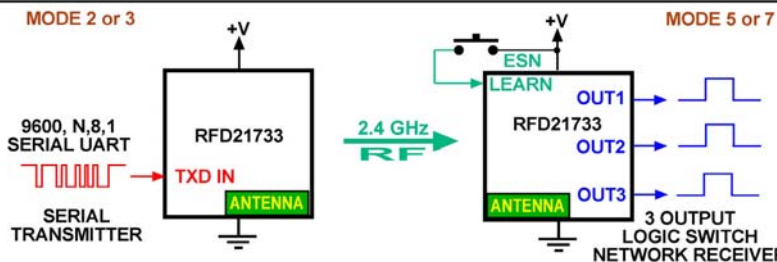

When a byte is received by the serial transmitter, OUT1, OUT2, OUT3, follow the states in bit position 4,5,6. Depending on the configured mode there is a 20 or 500 millisecond hang time. The receiver will only respond to transmitters if it has learned their ESNs.

To address a specific switch receiver, apply 5 bytes into the TXD pin. Byte 1, bit position 4,5,6 represent OUT1, OUT2, OUT3 on the receiver, all other bits must be zero. Byte 2-5 is the specific receiver's ESN. After sending the 5 bytes, wait at least 20 milliseconds before sending again.

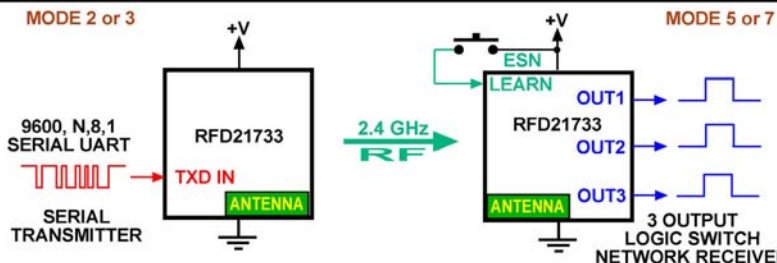

When 5 bytes are received in a row from a serial transmitter, OUT1, OUT2, OUT3, follow the states in Byte1, bit position 4,5,6. Depending on the configured mode there is a 20 or 500 millisecond hang time. The receiver will only respond if byte 2-5 contains it's ESN.

Eval Board Top and Bottom Labeled Views

All three eval boards can be powered from their on-board CR2032 3V battery or through the 12 pin 0.100 inch (2.54mm) pitch header, which can plug into directly into standard solderless breadboards or connect to mating a 0.100 inch (2.54mm) mating socket. The Eval Boards can work as stand-alone or can be wired to your application.

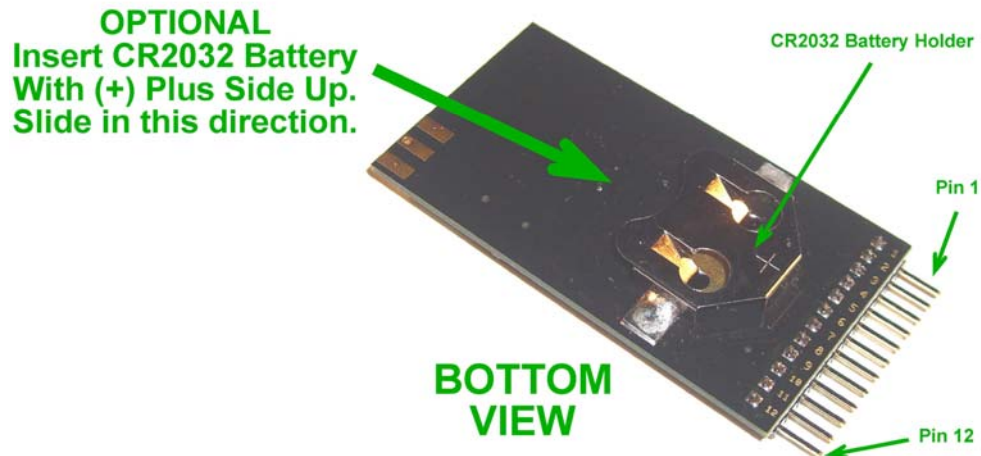
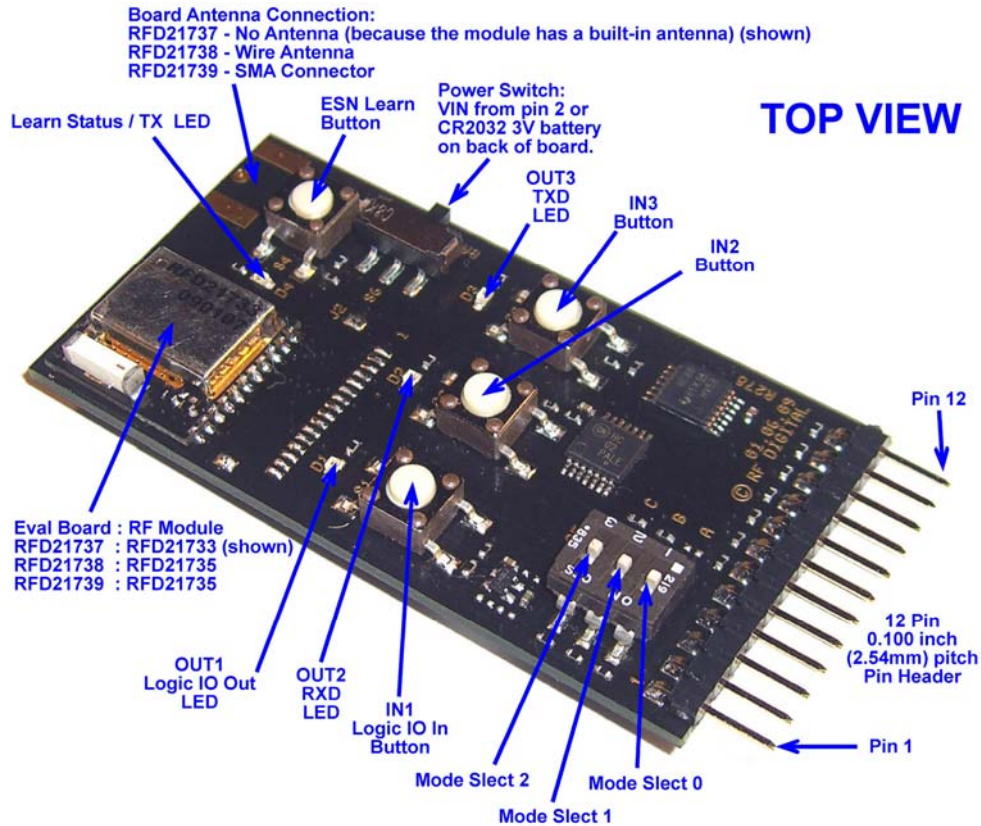

RFDP8 Mode Selector Switch

The 8 different modes of the RFDP8 Application Protocol are selected using the 3-position dip-switch S5 shown in the examples below. The 3 inputs have resistor pull-downs to ground, so when the switch is in its OFF (open) position, there is a low (0) on the input. When the switch is in its ON (closed) position, it connects the input to +V, which produces a high (1).

The proper way to read binary is MSB on the left and LSB on the right. Switch manufacturers label the switches from left to right and furthermore they commonly start with 1 rather than 0. So careful attention needs to be given to identify the switch positions. The binary is read from MSB to LSB, rather than LSB to MSB as shown in the examples below. To remove all doubt, only follow the examples shown below.

Mode 0
Active RFID
Transmitter

OFF	OFF	OFF

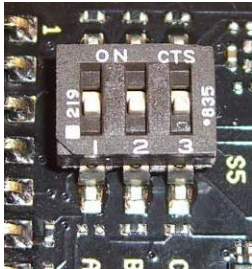

Mode 1
3-Input
Switch Logic
Transmitter

ON		
	OFF	OFF

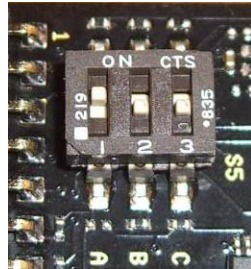

Mode 2
Serial UART
Transceiver
9600-8N1

	ON	
OFF		OFF

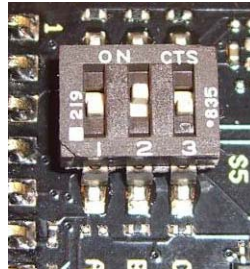

Mode 3
Serial UART
Transceiver
9600-8N1
Network

ON	ON	
		OFF

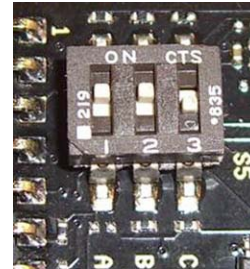

Mode 4
3-Output Switch
Logic Receiver
500ms Hang Time

		ON
OFF	OFF	

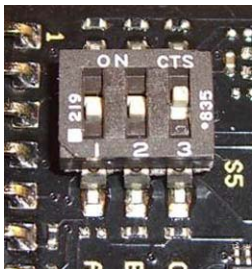

Mode 5
3-Output Switch
Logic Receiver
500ms Hang Time
Network

ON		ON
	OFF	

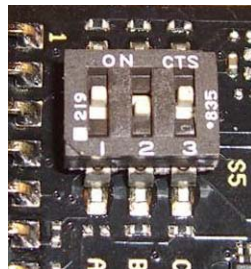

Mode 6
3-Output Switch
Logic Receiver
20ms Hang Time

	ON	ON
OFF		

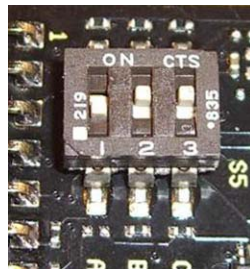

Mode 7
3-Output Switch
Logic Receiver
20ms Hang Time
Network

ON	ON	ON

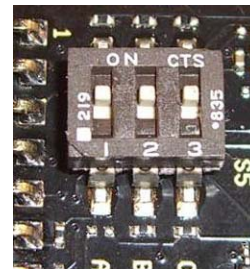

Eval Board Top and Bottom View Pinout

TOP VIEW

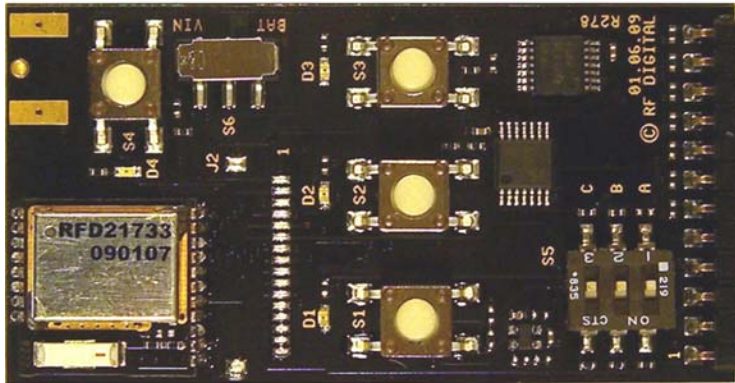

- 12 IN3 / OUT3 / TXD
- 11 IN2 / OUT2 / RXD
- 10 IN1 / OUT1 / LOGIC IO
- 9 LEARN / TX LED / STATUS
- 8 DO NOT CONNECT (must be open)
- 7 DO NOT CONNECT (must be open)
- 6 DO NOT CONNECT (must be open)
- 5 DO NOT CONNECT (must be open)
- 4 DO NOT CONNECT (must be open)
- 3 POWER ON (Tie to +V)
- 2 +V (+3V to +5V)
- 1 GND

BOTTOM VIEW



- 1 GND
- 2 +V (+3V to +5V)
- 3 POWER ON (Tie to +V)
- 4 DO NOT CONNECT (must be open)
- 5 DO NOT CONNECT (must be open)
- 6 DO NOT CONNECT (must be open)
- 7 DO NOT CONNECT (must be open)
- 8 DO NOT CONNECT (must be open)
- 9 LEARN / TX LED / STATUS
- 10 IN1 / OUT1 / LOGIC IO
- 11 IN2 / OUT2 / RXD
- 12 IN3 / OUT3 / TXD

Eval Board Power Supply and Logic Levels - Important

There is an internal 3.3 Volt (LDO) on the eval boards. At the (pin 2) +V input pin, **you can supply 2.1VDC minimum and a maximum of 3.6VDC**. When your supplied voltage is between 3.4V and 3.6V the internal regulator is in regulation and the internal supply to all parts will be 3.3V, and all signals on pins 9-12 will be at 3.3V logic. When 2.1V to 3.4V is supplied the internal 3.3V regulator is of regulation and tracks the input voltage (minus 100mv overhead). If you supply 2.5V your logic will be at 2.4V, and if you supply 2.1V your logic will be at 2.0V. The internal 3.3V regulator accept up to a 5V supply input, but at 5V supply, your logic levels on pins 9-12 will be at 3.3V, **so use caution**. So you will need to use 3.3V to 5V logic level shifters to run properly at 5V or you will cause damage to the module. When using a 5V supply, a very quick 5V level shifter method (**not to be used for production**) just for testing, which works in some cases would be to use a 22k resistor in series between the eval boards 3.3V logic and your 5V logic. There is a 47k pull down resistor internal to the board on pin 9-12 and this is just enough to switch the logic levels in both directions for a quick and dirty level shifter.

RFDP8 Firmware

RF Digital offers firmware for the RFD21743 modules meets many common user requirements. The firmware and a unique identifier are pre-programmed and tested at the factory. The programmed module is therefore immediately ready for use upon delivery.

The RFDP8 firmware use the 3 mode select inputs to select the operating mode. These inputs are sampled when the module powers-on.

Some of the operating modes have additional options which are described in the section for that mode.

The RFDP8 firmware cannot be modified by the user. For applications that require alternative functionality, contact RF Digital for information about custom firmware to fit your specific requirements.

Interference Immunity Algorithm

RF Digital's RFDP8 proprietary patent-pending frequency agility protocol operates in the internationally accepted 2.4 GHz band. The RFDP8's leading-edge advanced algorithm is not burdened by a heavy-weight stack as is BlueTooth, ZigBee, WLAN and other protocols, which are well suited for cross-manufacturer interoperability. The RFDP8 protocol is highly robust and effective where there is a need to penetrate through a high saturation of RF noise which is common in nearly all environments today. It is especially effective and can easily coexist in heavy WiFi environments, which very few technologies can do successfully without the need of excessive processing power. The protocol strategically changes channels frequently to deliver its payload to the destination device reliably, yet not too excessively as to demand too much internal processing power which allows it to run with a very low current consumption profile and fast start up times allowing substantial flexibility with implementation. The RFDP8 protocol reduces the amount of on-air traffic and unnecessary chatter due to its unique and highly efficient design, which does not require bilateral registration and association as do many other technologies today. The RFDP8 does not require ack-nacks to complete a packet delivery, it's unique technique of packet delivery, recovery and correction allows it to work as a one-way link, hence drastically simplifying users' applications which always results in more a robust wireless system. The RFDP8 protocol combined with RF Digital's leading-edge RF Module hardware delivers a highly robust method of delivering user data from point to point, point to multi-point or multi-point to multi-point, transmitter-receiver, transceiver, serial or switch on/off data modes. The protocol is designed to work seamlessly with RF Digital's hardware modules, the combination results in ultra long range at ultra low currents without concern for compliance approvals since modules such as the RFD21733 come with FCC approval for USA and have passed CE - ETSI emission testing for European requirements. The RFDP8 protocol adds several dB of range gain passively through it's advanced data recovery technique which pulls valid data out of a noisy environment adding effective gain which results in more range, delivering the net result, which is a very robust wireless system. All of this is built into the overhead of the RFDP8 protocol and RF Digital modules, so it's all done behind the scenes, allowing the user to focus on building their application and simply putting data into the radio device as a wireless pipe and easily receiving it on the other end.

Electronic Serial Number

Every RF Digital Module has its own 32-bit unique identifier (over 4 billion unique values), known as the Electronic Serial Number, or ESN. This value is assigned at the factory and cannot be changed by the user.

The ESN is included in every packet that is transmitted, as part of the protocol overhead and is transparent to the user.

The user does not ordinarily need to know what the ESN is. However, in certain cases it is helpful to know the serial number, and so a mechanism has been provided to read out the ESN. This method is documented in the UART section below.

Network Mode

The UART and the Receiver with logic output can be configured to accept data only from transmitters with which it has been associated, i.e. in its network.

When in network mode, a module must “learn” the ESN of any module which it wishes to “hear.” The LEARN signal (listed in the UART and receiver sections below) is usually an input, pulled to GND through an external resistor. When LEARN is driven high for at least 20ms and then allowed to return to GND, the module enters learning mode.

While in learning mode, the LEARN signal is changed to an output and driven high. During this time, the module will learn the ESN of the first module that sends any data; the data will be discarded, the ESN of the transmitting module will be learned by the receiving module. The receiving module indicates that it has learned the ESN by toggling the LEARN output on and off quickly three times.

After learning the transmitting modules ESN, or after 10 seconds pass, the module will exit learning mode by driving LEARN low and then changing it back to an input.

The LEARN / STATUS pin is bidirectional, it is an input when in the LEARN state and an output when in the STATUS state, so you must drive it using a series resistor, we recommend you not use any value smaller 1k ohm to limit the amount of load current. There is an internal 47k pull down resistor, so if you use a value of 1k series resistor that will easily be enough to drive it high against the internal 47k pull down resistor.

Modules can learn up to 60 unique ESN's. ESN's cannot be deleted individually. The list of learned ESN's can be completely cleared by holding the LEARN signal high for at least 10 seconds and then releasing it. The module will erase its ESN list, and then drive the LEARN signal in a fast alternating high/low pattern for a few seconds to indicate that the ESN list is now empty.

Once a module has learned the ESN of another module, it will accept any and all data from that module only and not any other modules. Up to 60 unique transmitters can be taught to one receiver. If a module is configured to any of the 3 Network modes and it has not learned any transmitters ESN, then it will not receive and output any data, until it learns at least one transmitter.

This network feature can be used for peer-to-peer networks, point to multi-point networks, multi-point to multi-point networks. The association can be between two units for simple functions like opening a garage door or with many units to form complex networks with multiple nodes.

Modes

Mode 0 – Active RFID Transmitter

Pin #	Pin Label	Direction	Function
13	+V	Input	+V Power
10	GND	Input	Ground
16	Mode Select 0	Input	Tie to GND
17	Mode Select 1	Input	Tie to GND
3	Mode Select 2	Input	Tie to GND
4	TX LED	Output	Toggles high during transmission (1 blink every 2 seconds)
5	IN1	Input	Active high switch input #1 (optional) if not used, pull to GND.
6	IN2	Input	Active high switch input #2 (optional) if not used, pull to GND.
7	IN3	Input	Active high switch input #3 (optional) if not used, pull to GND.

The Active RFID Transmitter transmits a packet with its ESN every 2 seconds when the three inputs are all at a low logic level. If any of the three inputs go high, the module transmits the state of all three inputs every 15 ms, until all three inputs are low. The logic inputs should be tied low if they are not used in the end application.

The module is active during transmit for 15ms, but remains in an ultra-low power mode for the rest of the 2 second interval. The average power over time is measured in microamps, such that a CR2032 battery should provide about 60 days of continuous use.

During the 15ms transmission times the current consumption is about 15mA and during the roughly 2 seconds the current is about 2uA.

If you determine that you need a different period of transmission other than the 2 seconds, a shorter period or a longer period, then simply use Mode 1 shown below and use your own controller to pulse one of the 3 inputs at the desired period and it will perform exactly the same function as the RFID transmitter Mode 0.

If longer periods of use are required, a larger battery can be used to allow it to run up to years of time without replacing the battery, or contact RF Digital to inquire about a custom time setting which will reduce the transmission interval thus reducing the average power consumption.

The Mode 0 is effectively Mode 1, except, in addition to Mode 1 features, the module will internally cause input 1 to transmit on its own every 2 seconds.

Mode 1 – Input Logic Transmitter

Pin #	Pin Label	Direction	Function
13	+V	Input	+V Power
10	GND	Input	Ground
16	Mode Select 0	Input	Tie to +V
17	Mode Select 1	Input	Tie to GND
3	Mode Select 2	Input	Tie to GND
4	TX LED	Output	Toggles high during transmission (1 blink every 15 milliseconds)
5	IN1	Input	Active high switch input #1 (optional) if not used, pull to GND.

6	IN2	Input	Active high switch input #2 (optional) if not used, pull to GND.
7	IN3	Input	Active high switch input #3 (optional) if not used, pull to GND.

When all three switch inputs are low, the module does not transmit, but remains in an ultra-low-power state consuming only 2uA.

When any of the three switch inputs go high, the module transmits the state of all three inputs. As long as any of the three inputs remain high, the module continues to transmit the state of all three inputs every 15ms, while transmitting it will draw about 15mA.

You can also tie any of the three inputs to +V and then connect a switch between +V of the module and your supply, then once you apply +V to the module it will instantly transmit as fast as possible, this is the method can be used to consume zero current when not in use such as in the case of garage door openers or keyfobs and can be used for many years without consuming any current at all.

Modes 2 – 9600 baud UART

Pin #	Pin Label	Direction	Function
13	+V	Input	+V Power
10	GND	Input	Ground
16	Mode Select 0	Input	Tie to GND
17	Mode Select 1	Input	Tie to +V
3	Mode Select 2	Input	Tie to GND
4	Not Used	Output	Do not connect, not used.
5	Logic IO	I/O	Bidirectional switch logic I/O, if not used, pull to GND.
6	RXD	Output	RX Data Out, UART output of received data.
7	TXD	Input	TX Data In, UART input of data to transmit.

Modes 3 – 9600 baud UART (Network)

Pin #	Pin Label	Direction	Function
13	+V	Input	+V Power
10	GND	Input	Ground
16	Mode Select 0	Input	Tie to +V
17	Mode Select 1	Input	Tie to +V
3	Mode Select 2	Input	Tie to GND
4	Learn / Status	I/O	Pulse high to enter learn mode and LED Learn Status Output.
5	Logic IO	I/O	Bidirectional switch logic I/O, if not used, pull to GND.
6	RXD	Output	RX Data Out, UART output of received data.
7	TXD	Input	TX Data In, UART input of data to transmit.

9600 baud half-duplex UART, suitable for connection to a microcontroller, or a level translator (such as a MAX202) to an RS-232 port. RF transmission takes priority over RF reception, so that a module will not receive anything over the air if it is given a full-speed stream of serial data on TX_in.

The UART is configured for 9600 baud, 8 data bits, 1 stop bit, and no parity. Because the module does not perform any parity checking on the data stream, it is possible to use 7 data bits with even or odd parity instead of 8 data bits with no parity.

When in UART mode, the module remains in an active state with the radio enabled in receive mode.

If you are only using the module as a receiver, you must terminate the TXD line with a pull up resistor to +V so you do not leave a floating input which may cause unintentional transmissions by the module detecting anything other than a solid logic level on the TXD pin. Note you can also pull it to ground to terminate it if you require, but most applications will want to terminate by a pull up resistor if the pin is unused.

There is a general purpose IO line in mode 2 and mode 3 which is pin 5 on the module and the label in these modes are called LOGIC IO. This is a powerful feature which allows you to not only send serial data back and forth using the TXD and RXD, but in addition you can apply a high logic level to the LOGIC IO pin and it will start transmitting without the need for sending serial data into the TXD pin. Once it is transmitting, any mode 2 or mode 3 receiver's LOGIC IO pin will go high for the same duration of time. This allows you to send switch data between two transceivers as well as serial data. In some applications this is very useful since you can use this feature to have one master device turn on a slave device and wait for the slave device to be ready to communicate using the UART and then begin sending data to it rather than keeping it awake all the time.

The LOGIC IO pin (pin 5) on the RFD21733 MUST be terminated when in mode 2 or 3, (pulled to ground with a resistor) or it will float and cause the transmitter sporadically. All inputs must be terminated properly and this one is no exception. If you do not plan on using it, tied it to ground using any resistor between 10k to 47k. Note this is a BI-DIRECTIONAL pin so do not directly connect to an output or to ground, you must use a pull down resistor. Also, when in use with a microcontroller pin you should consider using a series 1k resistor as well between the LOGIC IO pin and your controller pin since that will prevent any possible conflicts that might happen if you chose to drive the pin when it was an output by mistake, which can be a very common occurrence.

End-to-End Latency

In order to use the radio efficiently, the RFDP8 firmware buffers data received from the UART into packets which are transmitted over the radio. The firmware transmits a packet when it has buffered 12 bytes of data, or 15ms after receiving a byte of data. On the receiving end, data will be transmitted over the UART at line speed, with no pauses between the bytes (other than the RS-232 start and stop bits). The buffering allows for the RFDP8 to support a full 9600 baud data rate.

The buffering and latency may cause problems with certain microcontrollers that can not tolerate serial data into their UART in a constant stream at 9600-8N1. One possible solution is to add a 16ms delay on the transmitting side which will cause each byte to be sent in its own packet by the module and therefore on the receiving end the bytes will be outputted at a pace of one byte every 16ms which will help your controller of choice handle the fast UART data.

As an example, consider a scenario where one system is sending a byte of data every 8ms. When module 1 receives the 1st byte on its UART, the 15ms timer begins. The 2nd byte arrives before 15ms elapses, and so the first two bytes are sent in a single packet over the air to Module 2. Module 2 will transmit the bytes on its UART with no delay between them. Module 1 receives the third byte on its UART, and re-starts the 15ms timer. As with the 2nd byte, the 4th byte arrives before 15ms elapses, and so the 3rd and 4th bytes are also sent in a single packet over the air, as illustrated in the following timing diagram.

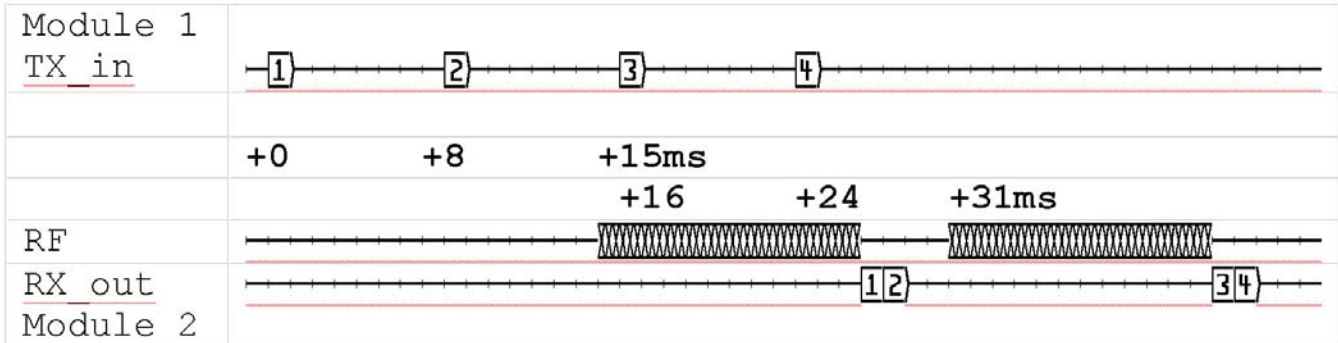

Bi-Directional IO Signal Operation

UART mode includes an additional bi-directional general-purpose IO line. The IO signal is generally an input, and should be pulled to GND with an appropriately sized resistor (for example 10k). If the IO signal is driven high, the module will transmit this information, and any UART which receives the data will turn its IO signal into an output and drive it high. This will continue until 20ms pass without receiving any new data, or until the module receives a packet which indicates that the IO signal should be driven low and turned back to an input. The state of the IO signal does not require any extra data in the radio stream, and so is “free” in the packet overhead.

When the module is driving its IO signal high, it will periodically change the pin to an input and check to see if it remains high, before changing it back to an output. This causes a periodic dip in the signal, 1ms every 12-16ms, and so any circuitry which relies on a steady-state output from the IO signal should include conditioning (for example a retriggerable one-shot with a hold time of 2ms) to avoid adverse effects.

ESN Read-back

In certain applications, it is helpful to know the ESN of a module. There is a provision in both UART modes to read back the ESN when the module comes out of reset. ESN read-back is not available in any of the other modes.

Pin 14 on the RFD21733 / RFD21735 is marked as Do Not Connect, this pin normally is not connected for all applications except for reading back the ESN. So that is why it is mentioned here and not anywhere else. The reset signal does not have to be used, instead of using reset you can use power the module off and then back on. The reset is a cleaner way of doing it. If you are using the RFD21737, RFD21738, RFD21739 eval boards, the reset signal is available on pin 5 of the 12 pin connector. Internal to the RFD21733 / RFD21735 there is a 3.3K pull up resistor on the reset signal, so when you are not using it, you can just leave it open.

To activate ESN read-back:

1. Place the module in a reset state by holding the /RESET signal low.
2. Hold the LEARN signal high.
3. Release the /RESET signal.
4. Wait 250ms. If the LEARN signal goes low at any time during this 250ms interval, the module immediately exits ESN read-back mode.
5. Release the LEARN signal.
6. Send the string “READ ESN” (all capitals, one space between the two words) at 9600-8N1 into the module on the TXD Input signal. If this string is not received within 1 second, the module exits ESN read-back mode.

The module will respond with the ESN and a firmware identifier on the RXD Output signal at 9600-8N1, and then exit ESN read-back mode. An example of the output is:

314CE686:RFDP8 v1.2 11/18/08 08:45:16\$

The ESN is 8 characters, representing a 32-bit number in hexadecimal format. A colon separates the ESN from the Firmware ID. The Firmware ID is 32 bytes long. The output is terminated with a carriage return/line feed pair.

When the module exits ESN read-back mode, or if the LEARN signal is not high when the module exists reset, the module will enter regular operation in Mode 2 or 3, according to the mode select signals.

Modes 4 – Receiver with Logic Output (500ms hang-time)

Pin #	Pin Label	Direction	Function
13	+V	Input	+V Power
10	GND	Input	Ground
16	Mode Select 0	Input	Tie to GND
17	Mode Select 1	Input	Tie to GND
3	Mode Select 2	Input	Tie to +V
4	Not Used	Output	Leave open, not used.
5	OUT1	Output	Active high switch output #1, 500 millisecond hang-time.
6	OUT2	Output	Active high switch output #2, 500 millisecond hang-time.
7	OUT3	Output	Active high switch output #3, 500 millisecond hang-time.

Modes 5 – Receiver with Logic Output (Network) (500ms hang-time)

Pin #	Pin Label	Direction	Function
13	+V	Input	+V Power
10	GND	Input	Ground
16	Mode Select 0	Input	Tie to +V
17	Mode Select 1	Input	Tie to GND
3	Mode Select 2	Input	Tie to +V
4	Learn / Status	I/O	Pulse high to enter learn mode and LED Learn Status Output.
5	OUT1	Output	Active high switch output #1, 500 millisecond hang-time.
6	OUT2	Output	Active high switch output #2, 500 millisecond hang-time.
7	OUT3	Output	Active high switch output #3, 500 millisecond hang-time.

Modes 6 – Receiver with Logic Output (20ms hang-time)

Pin #	Pin Label	Direction	Function
13	+V	Input	+V Power
10	GND	Input	Ground
16	Mode Select 0	Input	Tie to GND
17	Mode Select 1	Input	Tie to +V
3	Mode Select 2	Input	Tie to +V
4	Not Used	Output	Leave open, not used.
5	OUT1	Output	Active high switch output #1, 20 millisecond hang-time.
6	OUT2	Output	Active high switch output #2, 20 millisecond hang-time.
7	OUT3	Output	Active high switch output #3, 20 millisecond hang-time.

Modes 7 – Receiver with Logic Output (Network) (20ms hang-time)

Pin #	Pin Label	Direction	Function
13	+V	Input	+V Power
10	GND	Input	Ground
16	Mode Select 0	Input	Tie to +V
17	Mode Select 1	Input	Tie to +V
3	Mode Select 2	Input	Tie to +V
4	Learn / Status	I/O	Pulse high to enter learn mode and LED Learn Status Output.
5	OUT1	Output	Active high switch output #1, 20 millisecond hang-time.
6	OUT2	Output	Active high switch output #2, 20 millisecond hang-time.
7	OUT3	Output	Active high switch output #3, 20 millisecond hang-time.

In modes 4 through 7, the module is always in receiving mode.

The receiver drives its outputs to match the values received in a packet from a transmitter. This allows up to 8 possible (2^3) combinations on the receiver's outputs.

Since a transmitter does not send any data when all of its inputs are low, there must be a mechanism for turning off the receiver's outputs in the absence of data. When Mode Select 1 is pulled to GND, the receiver will maintain its output state for 500ms or until it receives new data, whichever comes first. The 500ms is referred to as the "hang time," or the time that the outputs will "hang" in the absence of new data. If Mode Select 1 is pulled to +V, the hang time is 20ms.

Hang time is a trade-off between latency and resiliency to packet loss. With all RF systems sometimes a packet will be lost, especially as the distance between the transmitter and the receiver grows. If an output is connected to a relay driver, packet loss will result in chattering on the relay, which will not have good results. The 500ms hang time is perfect for applications like a keyless entry system or a garage door opener.

For faster switching to the "all off" state, the 20ms hang time is preferred. Since a transmitter sends new data every 15ms, the time delay to turn off all outputs is only 5ms more than to update the outputs to a different state where at least one of them is still driven high.

The following timing diagrams show the operation of a logic transmitter and a logic receiver with the different hang time options.

In the first diagram, the logic transmitter's inputs are all asserted, and then sequentially de-asserted. There is a small delay between the transmitter input going high and the corresponding output on the receiver going high, due to the time required to transmit over the air.

Note that when the last input on the transmitter is de-asserted, there is a 500ms delay before the receiver de-asserts its last output.

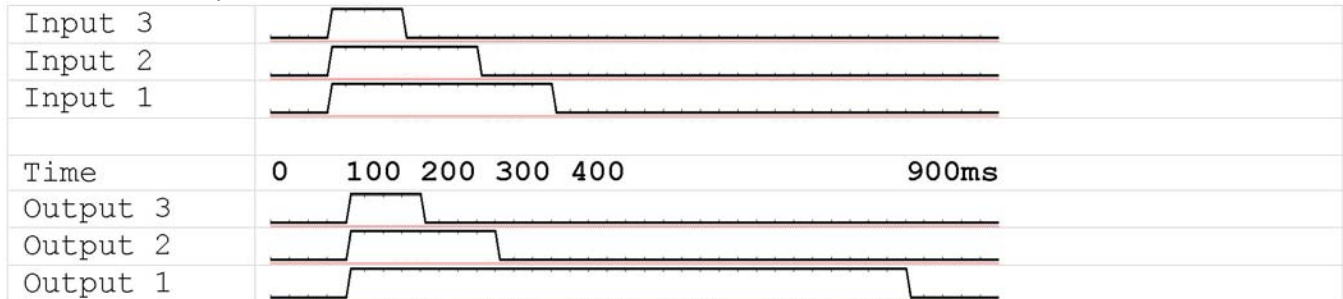

The second diagram shows the same operation at the transmitter, but with the receiver configured with a 20ms hang time.

Note that shortly after the last input is de-asserted, the receiver updates its output state to turn off all outputs.

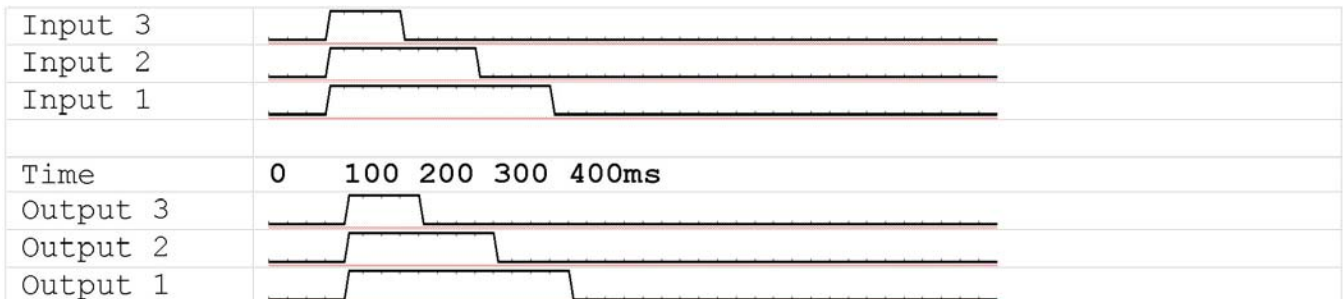

Communication between UART and Switch Logic Receiver/Transmitter

The Logic Receiver and Transmitter modes are able to communicate with a module operating in one of the UART modes, which opens up a wide range of possible applications involving PC's or embedded systems with serial communications capability.

Logic Transmitter to UART

A Logic Transmitter (whether RFID or not) sends the state of its inputs as a single byte of data, followed by its ESN as four bytes. A UART can receive this packet and output it as a binary stream to a PC serial port or an embedded microcontroller. The format of the data is:

Byte	Bit 7	Bit 6	Bit 5	Bit 4	Bit 3	Bit 2	Bit 1	Bit 0
1		Input 3	Input 2	Input 1/ RFID				RFID
2	ESN Byte 1							
3	ESN Byte 2							
4	ESN Byte 3							
5	ESN Byte 4							

In the first byte, bits 6 through 4 carry the state of the logic inputs, with a '1' indicating the logic input on the transmitter is high, and a '0' indicating it is low. An RFID Transmitter will set both bits 0 and 4 to indicate that it is a periodic transmission from an RFID Transmitter, and is set to '1' if this is the case.

For example, if an RFID Transmitter with ESN 314CE686 sent a packet on its 2-second interval, a UART would receive the bytes 11 31 4C E6 86 in binary format.

If input #1 on that same RFID transmitter were pulled high, the UART would receive the bytes 10 31 4C E6 86 in binary format; since bit 0 is clear, the receiver can tell that this was not a periodic transmission.

Most ESN's will contain at least one unprintable character, and so this data will not be suitable for displaying directly in a terminal package (such as HyperTerminal), but a PC-based program or an embedded system (such as the BASIC Stamp) can collect the data and display it in a more friendly fashion.

The ESN which the UART receives is the same one that is in the packet header. If the UART is in Network Mode, and has not learned the ESN, it will never receive the packet, and there will be no output on the serial port.

UART to Logic Receiver

A UART can also send data to a logic receiver, which will decode the data and assert its outputs as though it received a packet from a logic transmitter. The data format is very similar to the one described in the previous section. The differences matter only when the receiver is in Network Mode.

The UART must follow a packet with at least 15ms of no data so that all bytes as described below are sent as a single packet.

Note that a UART can send a single zero byte – all bits clear – to force a receiver to turn off its outputs immediately, regardless of hang time.

Format 1:

Byte	Bit 7	Bit 6	Bit 5	Bit 4	Bit 3	Bit 2	Bit 1	Bit 0
1		Output 3	Output 2	Output 1				

When the receiver is not in Network Mode, the receiver will accept any packet it receives, and so this is the preferred format.

A receiver in Network Mode will use the UART's ESN from the packet header to determine if it should accept the packet. This allows one UART to send the same data to multiple receivers, provided that each receiver has learned the UART's ESN.

Format 2:

Byte	Bit 7	Bit 6	Bit 5	Bit 4	Bit 3	Bit 2	Bit 1	Bit 0
1		Output 3	Output 2	Output 1				
2	ESN Byte 1							
3	ESN Byte 2							
4	ESN Byte 3							
5	ESN Byte 4							

To allow individual addressing of receivers in Network Mode, the UART can send a particular receiver's ESN after the byte for the logic state. In this case, the receiver will only accept the packet if the ESN in the data portion matches the receiver's own ESN.

If the receiver is actively learning ESN's, it will learn only the ESN from the packet header; the ESN in the data portion will not be learned.

Electrical Characteristics

Operating Conditions

Symbol	Parameter	Minimum	Typical	Maximum
VDD	Supply voltage	1.9V	3.0V	3.6V
	Operating Temperature	-40°C		+85°C

Power Consumption

Conditions: VDD = 3.0V, T_A = +25°C

Logic Transmitter or Active RFID Transmitter

Parameter	Minimum	Typical	Maximum
Ultra-low power mode - Switch Logic Transmitter / RFID		2uA	

UART or Switch Logic Transmitter / Receiver

Parameter	Minimum	Typical	Maximum
Listening - Receiving		17mA	
Transmitting		14mA	

FCC NOTICE

Relating to Model Number RFDANT (RFD Stock Code: RFD21743)

LABELING REQUIREMENT FOR USA FCC CERTIFICATION

This device has a modular approval from the FCC. You must place the following label outside, on your product in an obvious location.

Permanently attached label in a conspicuous location with the following statement:

This device contains FCC ID: UYI-RFDANT RF module that complies with Part 15 of the FCC Rules. Operation is subject to the following two conditions:

**(1) This device may not cause harmful interference and
(2) this device must accept any interference received, including interference that may cause undesired operation.**

NOTES:

1. The FCC does not specify the size of the label or the lettering thereon. The only requirement is that the text be legible.
2. If the entire label can not be placed on the unit due to space constraint (e.g. Pacemaker), only "contains an FCC ID: UYI-RFDANT" may be displayed on the unit. In such cases, the compliance statement will have to be included in the "instruction to the user."

***** It is the users responsibility to determine if their device requires additional approvals *****

SAMPLE FCC STATEMENT TO BE INCLUDED IN USER'S MANUAL

INSTRUCTION TO THE USER (if device contains a digital device)

This equipment has been tested and found to comply with the limits for a class B digital device, pursuant to part 15 of the FCC Rules. These limits are designed to provide reasonable protection against harmful interference in a residential installation. This equipment generates, uses and can radiate radio frequency energy and if not installed and used in accordance with the instructions, may cause harmful interference to radio communications. However, there is no guarantee that interference will not occur in a particular installation. If this equipment does cause harmful interference to radio or television reception, which can be determined by turning the equipment off and on, the user is encouraged to try to correct the interference by one or more of the following measures:

- * Reorient or relocate the receiving antenna.
- * Increase the separation between the equipment and receiver.
- * Connect the equipment into an outlet on a circuit different from that to which the receiver is connected.
- * Consult the dealer or an experienced radio/TV technician for help.

The user is cautioned that changes and modifications made to the equipment without the approval of manufacturer could void the user's authority to operate this equipment.

RoHS

Declaration Of Conformity

RF Digital declares that part numbers

- **RFD21731**
- **RFD21732**
- **RFD21733**
- **RFD21734**
- **RFD21735**
- **RFD21736**
- **RFD21737**
- **RFD21738**
- **RFD21739**
- **RFD21741**
- **RFD21742**
- **RFD21743**
- **RFD21772**
- **RFD21773**

are manufactured with RoHS materials.

The RFD21743 RFDANT is a full 2.4 GHz radio transceiver including the RFDP8 protocol, completely built into an antenna form factor allowing the entire radio transceiver to be outside your product, were only the power and signal cable will extend into your product enclosure to then be connected to your PCB with a simple 1.5mm SMT or THROUGH HOLE connector.

It has already passed FCC testing and in the documentation phase and therefore FCC Modular Approval is pending and should be available Aug-Sep 2010 time frame.

The RFD21743 RFDANT is currently available, as well as it's eval board which is the RFD21740. The RFD21743 is functionally identical to the RFD21733 module and the RFD21740 works just like the RFD21737 eval board except it has an 11 pin 1.5mm connector on it so the RFDANT RFD21743 can plug into it for use with any other RFDP8 product from RF Digital.

The RFD21743 has been range tested at 2,000 feet which is 4x the range of the RFD21733 which is at 500 feet. No special PCB layout is needed for the RFD21743, simply just put a connector on your PCB and you are done . All this substantial range increase is achieved all without any increase in current or battery consumption.

The RFDANT is RF Digital's Worldwide Patent Pending Radio Inside Antenna product, which is a complete radio transceiver and antenna mounted inside of an antenna enclosure, suitable for mounting to virtually any type of end-product.

The entire radio transceiver is mounted inside the antenna enclosure, so there is no loss of RF power to the antenna from the module, and results in the most effective power transfer ratio possible, providing lowest power consumption possible to achieve a specific range.

The radio being inside of the antenna and outside the enclosure allows for more room inside the enclosure for the designers application electronics.

Minimal interference with the internal electronics of the enclosure results in better range and performance of the wireless system.

The actual effective antenna is pushed away from the enclosure, which reduces the effect of holding the enclosure, therefore improving the performance, range and predictability of the users wireless system.

Logic level signals are used through an unshielded cable (not coax) to the RFDANT, which can be run for long distances without any loss to the performance of the wireless transceiver.

By the antenna and module being fully outside allows for easy retrofit of nearly any product due to it not consuming any internal space inside the enclosure, drill a hole and screw it in, add a nut inside to secure it and wire the logic level signals to your electronics.

Mount on metal or plastic enclosures with no worry about ground effects.

Stable Antenna Pattern providing substantial, well-distributed, passive-gain for transmit and receive, results longer repeatable range from your wireless system.

RFDANT - RFD21743 - FCC Approved

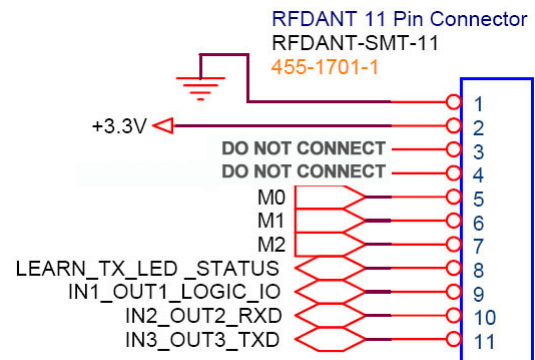
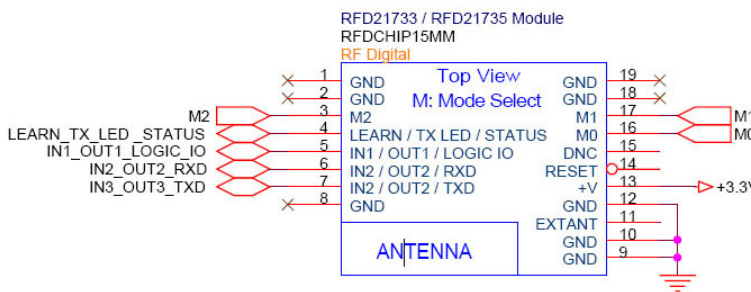

The pin out on the left is of the RFD21733 / RFD21735 module which is referenced through out this data sheet. To wire the RFDANT 11 pin connector simply match up the pin labels shown in both drawings above. Treat the RFDANT RFD21743 exactly as if it were an RFD21733 module and wire it the same way, except follow the pin outs shown above. The BLACK wire on the RFD21743 connector is pin 1.

RFDANT - RFD21743 Mating Connectors

Mating connectors for the 11 pin RFDANT connector, these part numbers can be found at Digikey in the USA <http://www.digikey.com> or at any other distributor. They are standard connectors and you may use other manufacturers as well.

- 1) Top Entry, Through Hole Type, 11 pos
 - a. Digikey P/N 455-1666-ND
 - b. Manufacturer P/N: B11B--ZR
- 2) Side Entry, Through Hole Type, 11 pos
 - a. Digikey P/N 455-1678-ND
 - b. Manufacturer P/N: S11B--ZR
- 3) Top Entry, SMT Type, 11 pos
 - a. Digikey P/N 455-1690-2-ND
 - b. Manufacturer P/N: B11B—ZR-SM4-TF
- 4) Side Entry, SMT Type, 11 pos
 - a. Digikey P/N 455-1701-2-ND
 - b. Manufacturer P/N: S11B—ZR-SM4-TF

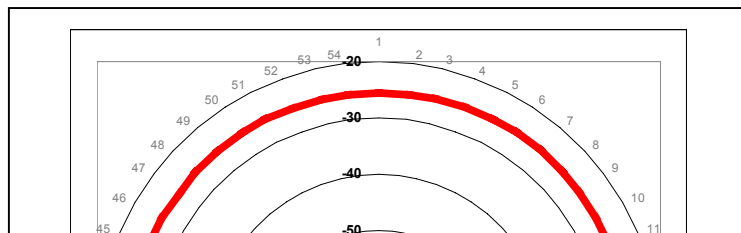

RFDANT RFD21743 high performance antenna patterns are easily achieved without any RF considerations or knowledge because the 11 pin cable and connector only carries power and data signals so NO RF cable

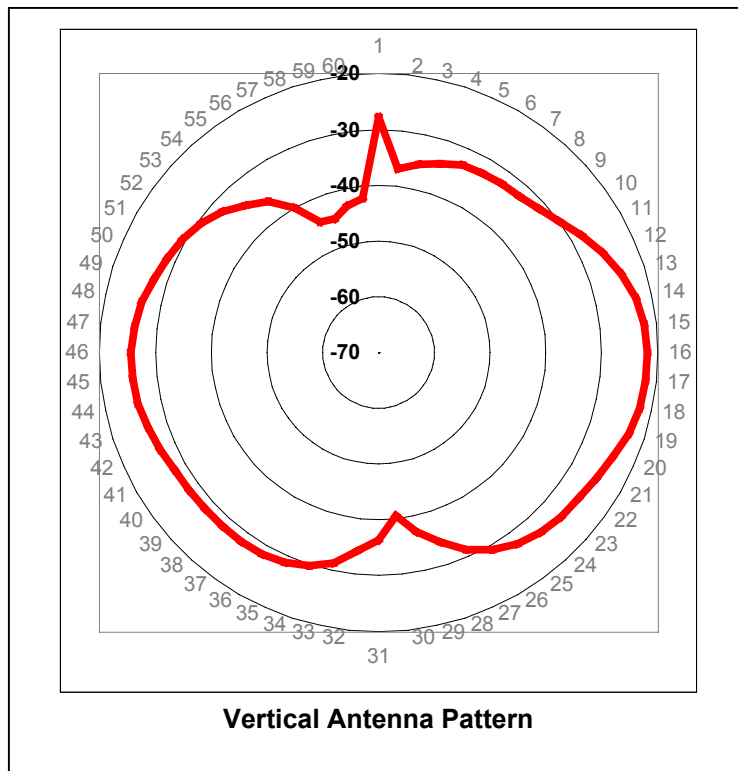

RFD21773 Eval board (for RFD21743 RFDANT)

RFD21773 Eval board with RFDANT 11 pin connector.

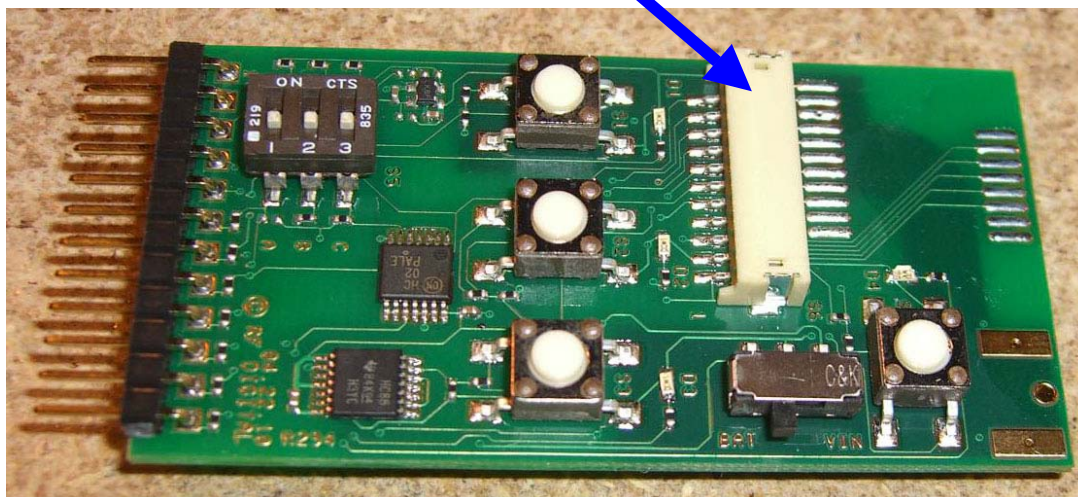

RFD21773 Eval board with RFDANT RFD21743 plugged into the eval board connector. This is a polarized connector and there is only one way to plug in the connector. The black wire is ground and is located close to the slide switch as shown below. The RFD21773 functions exactly like the RFD21737.

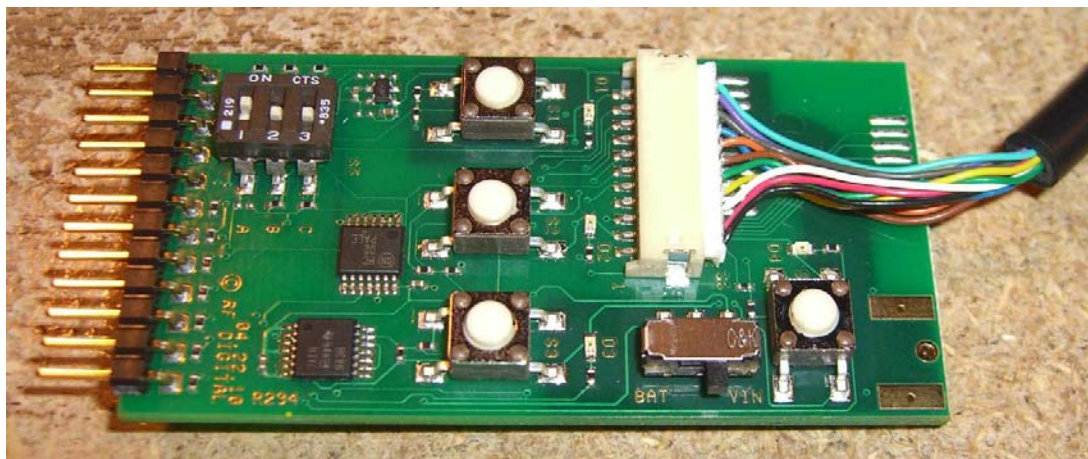

© Copyright,
RF Digital Corp.
9/2/2010 12:02 PM
Patents Pending

RoHS
FCC APPROVED

RF DIGITAL
C O R P O R A T I O N

13715 Alton Pkwy • Irvine • CA • 92618
Tel: 949.610.0008 • Fax: 949.610.0009
www.rfdigital.com • sales@rfdigital.com

RFDP8
RFDANT
RFD21743

Eval Board
RFD21773

Important Notice

RF Digital reserves the right to make corrections, modifications, and/or improvements to the product and/or its specifications at any time without notice.

RF Digital assumes no liability for the user's product and/or applications.

RF Digital products are not authorized for use in safety-critical applications, including but not limited to life-support applications.

RF Digital assumes no liability for parts or their application beyond replacement or refunding the original purchase price.

All trademarks and trade names belong to their respective owners.

End of Document.