

Eclipse Series

RF Technology
rinfo@rftechnology.com.au

August, 1998

T350 / T500 Transmitter Operation and Maintenance Manual

This manual is produced by RF Technology Pty Ltd
10/8 Leighton Place, Hornsby NSW 2077 Australia
Copyright © 1998 RF Technology

Contents

1	Operating Instructions	5
1.1	Front Panel Controls and Indicators	5
1.1.1	PTT	5
1.1.2	Line	5
1.1.3	PWR LED	6
1.1.4	TX LED	6
1.1.5	ALARM LED	6
2	Transmitter Internal Jumper Options	7
2.1	JP2: EPROM type	7
2.2	JP3: Dc Loop PTT	7
2.3	JP4: Audio Input Source	7
2.4	JP6: Input Level Attenuation	7
2.5	JP7: Audio Response	8
2.6	JP8: Sub-audible Tone source	8
2.7	JP9/10/11: dc Loop Configuration	8
3	Transmitter I/O Connections	8
3.1	25 Pin Connector	8
4	Channel and Tone Frequency Programming	8
5	Circuit Description	9
5.1	VCO Section	9
5.2	PLL Section	10
5.3	Power Amplifier	10
5.4	600Ω line Input	11
5.5	Direct Coupled Audio Input	11
5.6	Local Microphone Input	11
5.7	CTCSS and Tone Filter	11
5.8	Audio Signal Processing	12
5.9	PTT and DC Remote Control	12
5.10	Micro-processor Controller	13
5.11	Voltage Regulator	13
6	Field Alignment Procedure	13
6.1	Standard Test Conditions	14
6.2	VCO Alignment	14
6.3	TCXO Calibration	14
6.4	Modulation Balance	15
6.5	Tone Deviation	15
6.6	Deviation	16
6.7	Line Input Level	16
6.8	Output Power	16

7	Specifications	17
7.1	Overall Description	17
7.1.1	Channel Capacity	17
7.1.2	CTCSS	17
7.1.3	Channel Programming	17
7.1.4	Channel Selection	17
7.1.5	Micro-processor	18
7.2	Physical Configuration	18
7.3	Front Panel Controls, Indicators and Test Points	18
7.3.1	Controls	18
7.3.2	Indicators	18
7.3.3	Test Points	19
7.4	Electrical Specifications	19
7.4.1	Power Requirements	19
7.4.2	Frequency Range and Channel Spacing	19
7.4.3	Frequency Synthesizer Step Size	19
7.4.4	Frequency Stability	19
7.4.5	Number of Channels	19
7.4.6	Antenna Impedance	19
7.4.7	Output Power	19
7.4.8	Transmit Duty Cycle	20
7.4.9	Spurious and Harmonics	20
7.4.10	Carrier and Modulation Attack Time	20
7.4.11	Modulation	20
7.4.12	Distortion	20
7.4.13	Residual Modulation and Noise	20
7.4.14	600Ω Line Input Sensitivity	20
7.4.15	HI-Z Input	20
7.4.16	Test Microphone Input	21
7.4.17	External Tone Input	21
7.4.18	External ALC Input	21
7.4.19	T/R Relay Driver	21
7.4.20	Channel Select Input / Output	21
7.4.21	DC Remote Keying	21
7.4.22	Programmable No-Tone Period	22
7.4.23	Firmware Timers	22
7.4.24	CTCSS	22
7.5	Connectors	22
7.5.1	Antenna Connector	22
7.5.2	Power and I/O Connector	24
7.5.3	Test Connector	24

A	Engineering Diagrams	24
A.1	Block Diagram	24
A.2	Circuit Diagrams	24
A.3	Component Overlay Diagrams	25
B	Parts List	26

WARNING

Changes or modifications not expressly approved by RF Technology could void your authority to operate this equipment. Specifications may vary from those given in this document in accordance with requirements of local authorities. RF Technology equipment is subject to continual improvement and RF Technology reserves the right to change performance and specification without further notice.

1 Operating Instructions

1.1 Front Panel Controls and Indicators

1.1.1 PTT

A front-panel push-to-talk (PTT) button is provided to facilitate bench and field tests and adjustments. The button is a momentary action type. When keyed, audio from the line input is disabled so that a carrier with sub-tone is transmitted. The front-panel microphone input is not enabled in this mode, but it is enabled when the PTT line on that socket is pulled to ground.

1.1.2 Line

The LINE trimpot is accessible by means of a small screwdriver from the front panel of the module. It is used to set the correct sensitivity of the line and direct audio inputs. It is factory preset to give 60% of rated deviation with an input of 0dBm (1mW on 600 Ω equivalent to 775mV RMS or about 2.2V peak-to-peak) at 1kHz. The nominal 60% deviation level may be adjusted by measuring between pins 6 and 1 on the test socket, and adjusting the pot. By this means an input sensitivity from approximately -30dBm to +10dBm may be established.

An internal jumper provides a coarse adjustment step of 20dB. Between the jumper and the trimpot, a wide range of input levels may be accommodated.

LED Flash Cadence	Fault Condition
5 flashes, pause	Synthesizer unlocked
4 flashes, pause	Tuning voltage out of range
3 flashes, pause	Low forward power
2 flashes, pause	High reverse (reflected) power
1 flash, pause	Low dc supply voltage
LED ON continuously	Transmitter timed out

Table 1: Interpretations of LED flash cadence

Indication	Fault Condition
Flashing, 8 per second	Synthesizer unlocked
Flashing, 4 per second	Tuning voltage outside correct range
Flashing, 2 per second	Low forward power
Flashing, 1 per second	High reverse power
Continuous	dc supply voltage low or high

Table 2: Interpretations of LED flash speed, for early models

1.1.3 POWER LED

The PWR LED shows that the dc supply is connected to the receiver.

1.1.4 TX LED

The TX LED illuminates when the transmitter is keyed. It will not illuminate (and an Alarm cadence will be shown) if the synthesizer becomes unlocked, or the output amplifier supply is interrupted by the microprocessor.

1.1.5 ALARM LED

The Alarm LED can indicate several fault conditions if they are detected by the self test program. The alarm indicator shows the highest priority fault present. Receivers using software issue 5 and higher use the cadence of the LED flash sequence to indicate the alarm condition. Refer to table 1. Receivers using software issue 4 and lower use the LED flash rate to indicate the alarm condition. Refer to table 2.

2 Transmitter Internal Jumper Options

In the following subsections an asterisk (*) signifies the standard (Ex-Factory) configuration of a jumper.

2.1 JP2: EPROM Type

Condition	Position
27C256	2-3 *
27C64	1-2

2.2 JP3: Dc Loop PTT

This jumper enables or disables the keying of the PTT function by means of a dc signal passed down the 600 Ω line input pair. When enabled, JP9-JP11 control how the dc signal is configured with respect to an internal opto-coupler.

Condition	Position
dc loop connected (enabled)	1-2 *
dc loop not connected (bypassed)	2-3

2.3 JP4: Audio Input Source

Either the 600 Ω or the high-Z balanced inputs may be selected.

Condition	Position
600 Ω Input	2-3 *
High-impedance Input	1-2

2.4 JP6: Input Level Attenuation

This jumper permits coarse input sensitivity to be set.

Condition	Position
0dB attenuation	1-2 *
20dB attenuation	2-3

2.5 JP7: Audio Response

Condition	Position
750 uSec. pre-emphasis	1-2 *
Flat response	2-3

2.6 JP8: Sub-audible Tone Source

Condition	Position
Internal CTCSS	1-2, 4-5 *
External input	2-3, 5-6

2.7 JP9/10/11: dc Loop Configuration

These settings are only relevant when the PTT signal is to be used across the same wires as the audio. Refer to setting of JP3. They control the levels and connection into the audio balanced line circuitry.

Condition	JP9	JP10	JP11
Current Loop Input	ON	OFF	OFF *
12Vdc Loop source	OFF	ON	ON

3 Transmitter I/O Connections

3.1 25 Pin Connector

The D-shell 25 pin connector is the main interface to the transmitter. The pin connections are described in table 3.

4 Channel and Tone Frequency Programming

Channel and tone frequency programming is most easily accomplished with RF Technology TechHelp software or the Service Monitor 2000 software. This software can be run on an IBM compatible PC and provides a number of additional useful facilities. DOS and 32-bit versions are available.

TechHelp allows setting of the adaptive noise squelch threshold, provides a simple means of calibrating the forward and reverse power detectors, setting the power alarm preset levels, and enabling transmitter hang time and timeout time limits. TechHelp can be supplied by your dealer, distributor or by contacting RF Technology directly.

Function	Signal	Pins	Specification
dc power	+12 Vdc -12 Vdc	1, 14 13, 25	+11.4 to 16 Vdc
Channel Select	1 2 4 8 10 20 40 80	21 9 22 10 23 11 24 12	BCD Coded 0 = Open Circuit or 0 Vdc 1 = +5 to +16 Vdc
RS232 Data	In Out	15 2	Test and Programming use 9600, 8 data 2 stop bits
600Ω Line	High Low	20 6	Transformer Isolated Balanced 0dBm Output
150Ω / Hybrid		7 19	
Direct PTT input		3	Ground to key PTT
T/R Relay driver output		16	Open collector, 250mA/30V
Sub-Audible Tone Input	+	5	>10kΩ, AC coupled
	-	18	(1-250Hz)
High-Z Audio Input	+	4	>10kΩ, AC coupled
	-	17	(10Hz-3kHz)
External ALC input		8	<0.5V/1mA to obtain >30dB attenuation, O/C for maximum power

Table 3: Pin connections and explanations for the main 25-pin, D connector.

5 Circuit Description

The following descriptions should be read as an aid to understanding the block and schematic diagrams given in the appendix of this manual.

5.1 VCO Section

The Voltage Controlled Oscillator uses a junction FET which oscillates at the required transmitter output frequency. A varactor diode is used by the PLL circuit to keep the oscillator on the desired frequency. Transistor Q20 is used as an active filter to reduce the noise on the oscillator supply voltage. The VCO is keyed ON by the microcontroller through Q10. It is keyed ON when any of the PTT inputs are active and OFF at all other times.

The VCO output is amplified and buffered by monolithic amplifiers MA2 and MA3 before being fed to the PLL IC U6.

Amplifiers MA1, MA4 and MA5 increase the VCO output to approximately 4 mW to drive the power amplifier. MA1 is not switched on until the PLL has locked and had time to settle. This prevents any momentary off channel transmission when the transmitter is keyed.

5.2 PLL Section

Temperature compensated crystal oscillator XO1 is the frequency reference source for the PLL Synthesizer. The frequency stability of XO1 is better than 1 ppm and it can be synchronized to an external reference for improved stability. External reference option board 11/9119 is required when using an external reference.

XO1 is frequency modulated by the processed transmit audio signal from U7b. This extends the modulation capability down to a few Hz for sub-audible tones and digital squelch codes. A two point modulation scheme is used with the audio also being fed to the VCO to modulate the higher audio frequencies.

The 12.8 MHz output of XO1 is amplified by Q22 to drive the reference input of the PLL synthesizer IC U6. This IC is a single chip synthesizer which includes a 1.1 GHz pre-scaler, programmable divider, reference divider and phase/frequency detector. The frequency data for U6 is supplied through serial data link by the microprocessor.

The phase detector output signals of U6 are used to control two switched current sources. The output of the positive and negative sources (Q3 and Q6) produces the tuning voltage which is smoothed by the loop filter components to bias the VCO varactor diode D3.

5.3 Power Amplifier

The 4 mW output from the main board connects to the power amplifier board through a short miniature 5Ω coaxial cable.

Q2 on the power amplifier board increases the signal to approximately 200 mW. The bias current of Q2 is controlled by Q1 and the power leveling circuitry to adjust the drive to the output module U2.

U2 increases the power to 10-30 watts (depending upon options) before it is fed to the directional coupler, low pass filter and output connector. The directional coupler detects the forward and reverse power components and provides proportional dc voltages which are amplified by U1a and U1b. The forward and reverse voltages from U1a and U1b are compared to the DC reference voltage from RV1. The difference is amplified by U1c, Q3 and Q4.

The resulting control voltage supplies Q2 through R10, R12 and completes the power leveling control loop.

5.4 600 Ω Line Input

The 600 Ω balanced line input connects to line isolation transformer T1. T1 has two 150 Ω primary windings which are normally connected in series for 600 Ω lines. The dual primary windings can be used to provide DC loop PTT signaling or a 2/4 wire hybrid connection. All four leads are available at the rear panel system connector.

The secondary of T1 can be terminated with an internal 600 Ω load through JP5 or left un-terminated in high impedance applications.

5.5 Direct Coupled Audio Input

A high impedance (10k Ω) direct AC coupled input is available at the system connector. The direct coupled input connects to U9a which is configured as a unity gain bridge amplifier.

The bridge configuration allows audio signal inversion by interchanging the positive and negative inputs and minimizes ground loop problems. Both inputs should be connected, with one lead going to the source output pin and the other connected to the source audio ground.

5.6 Local Microphone Input

The local microphone input is provided for use with a standard low impedance dynamic microphone. The microphone output is amplified by U9a before connecting to analogue switch U10a. U10b inverts the local microphone PTT input to switch U10a ON when the microphone PTT button is pressed. U10a is OFF at all other times.

The local microphone audio has priority over the other inputs. Activation of the local microphone PTT input switches OFF the audio from the line or direct inputs through D16 and U10c.

5.7 CTCSS and Tone Filter

The CTCSS encoder module H1, under control of the main microprocessor U13, can encode all 38 EIA tones and (on some models) additional commonly-used tones.

The tone output of H1 connects to jumper JP8 which is used to select either H1 or an external tone source. The selected source is coupled to U9c which is a balanced input unity gain amplifier. The buffered tone from U9c is fed to 300 Hz low pass filter U7c. RV3, the tone deviation trimmer, is used to adjust the level of the tone

from U7c before it is combined with the voice audio signal in the summing amplifier U7a.

Back to back diodes D4 and D5 limit the maximum tone signal amplitude to prevent excessive tone deviation when external tone sources are used.

5.8 Audio Signal Processing

Jumper JP4 selects either the line or direct input source. The selected source is then connected to JP6. JP6 can be removed to provide 20 dB attenuation when the input level is above 10 dBm to expand the useful range of the line level trimmer RV4. The wiper of RV4 is coupled to the input of the input amplifier U9d. U9d provides a voltage gain of ten before connecting to the input of analogue switch U10c.

The outputs of U10a and U10c are connected to the frequency response shaping networks C52, R133 (for 750- μ s pre-emphasis) and C61, R55 (for flat response). JP7 selects the pre-emphasized or flat response.

The audio signal is further amplified 100 times by U7d. U7d also provides the symmetrical clipping required to limit the maximum deviation. The output level from U7d is adjusted by RV1, the deviation adjustment, before being combined with the tone audio signal in the summing amplifier U7a.

The composite audio from U7a is fed through the 3KHz low pass filter U7b. The filtered audio is coupled to the TCXO voltage tuning input and the modulation balance trimmer RV2.

RV2 adjusts level of the audio used to modulate the VCO. This primarily effects the deviation of audio frequencies above 500 Hz. RV2 is used to balance the high and low frequency deviation to obtain a flat frequency response relative to the desired characteristic.

5.9 PTT and DC Remote Control

Two main PTT inputs are provided. The first, a direct logic level input, is connected to pin 3 of the system connector. The transmitter can be keyed by applying a logic low or ground on pin 3. Pin 3 connects to the PTT logic and microprocessor through D10.

DC current loop control can be used for remote PTT operation. The current loop can be configured by JP9, JP10 and JP11 for use with either a remote free switch or a remote switched source.

Opto-isolator ISO1 is used to isolate the loop current signal from the transmitter PTT logic. The loop current passes through the input of ISO1 and the output of ISO1 connects to the PTT logic.

A bridge consisting of diodes D6, D8, D9 and D14 ensures correct operation regardless of the current polarity. Q17 limits the current and D7 limits the voltage input to ISO1. Any low voltage current source capable of providing 2 mA at 4 V or switching circuit with less than 4.8k Ω loop resistance can be used to switch the DC loop.

The test PTT button on the front panel and the local microphone PTT button will also key the transmitter. Both of these also mute the line audio input. The microphone line also enables that audio input.

5.10 Microprocessor Controller

The microprocessor controller circuit uses a single-chip eight bit processor and several support chips. The processor U13 includes non-volatile EE memory for channel frequencies, tones, and other information. It also has an asynchronous serial port, a synchronous serial port and an eight bit analogue to digital converter.

The program is stored in U5, a CMOS EPROM. U4 is an address latch for the low order address bits. U2 is used to read the channel select lines onto the data bus. U11 is an address decoder for U5 and U2. U3 is a supervisory chip which keeps the processor reset unless the +5 Volt supply is within operating limits. U1 translates the asynchronous serial port data to standard RS232 levels.

The analogue to digital converter is used to measure the forward and reverse power, tuning voltage and dc supply voltage.

The processor keys the VCO through Q10, switches the 9.2 Volt transmit line through Q14 and Q16, and the alarm LED D1 through Q1.

5.11 Voltage Regulator

The dc input voltage is regulated down to 9.4 Vdc by a discrete regulator circuit. The series pass transistor Q23 is driven by error amplifiers Q8 and Q18. Q9 is used to start up the regulator and once the circuit turns on, it plays no further part in the operation.

The +5 Volt supply for the logic circuits is provided by an integrated circuit regulator U14 which is run from the regulated 9.4 Volt supply.

6 Field Alignment Procedure

The procedures given below may be used to align the transmitter in the field. Normally, alignment is only required when changing operating frequencies, or after component replacement.

The procedures below do not constitute an exhaustive test or a complete alignment of the module, but if successfully carried out are adequate in most circumstances.

TCXO calibration may be periodically required owing to normal quartz crystal aging. A drift of 1ppm/year is to be expected.

Each alignment phase assumes that the preceding phase has been successfully carried out, or at least that the module is already in properly aligned state with respect to preceding conditions.

6.1 Standard Test Condition

The following equipment and conditions are assumed unless stated otherwise:

- AF signal generator with 600 Ω impedance, 150-3000Hz frequency range, with level set to 387mV RMS.
- Power supply set to 13.8Vdc, with a current capable of >5A.
- RF 50 Ω load, 30W rated, return loss <-20dB.
- Jumpers set to factory default positions.

6.2 VCO Alignment

1. Select a channel at the center frequency (half way between the highest and lowest frequencies for the model in question).
2. Disconnect the Audio input (no signal input).
3. Key the PTT line.
4. Measure the voltage between pins 9 and 1 of the test socket (TUNE V), and adjust C99 to obtain $4.5\pm 0.25V$, while the TX LED is ON and the ALARM LED is OFF.

6.3 TCXO Calibration

1. Select a channel at the center frequency (half way between the highest and lowest frequencies for the model in question).
2. Disconnect the Audio input (no signal input).
3. Key the PTT line.

4. Measure the carrier frequency at the output connector, and adjust XO1 until the correct carrier frequency is measured, $\pm 50\text{Hz}$.

6.4 Modulation Balance

1. Set RV3 fully counter clockwise (CCW) (sub-tone off).
2. Set RV1 fully clockwise (CW) (maximum deviation)
3. Set RV2 mid-position
4. Set JP7 for flat response
5. Key the transmitter on
6. Set the audio input to 150Hz, 0dBm.
7. Measure deviation and adjust RV4 (line Level) for a deviation of 5kHz (2.5kHz for narrow band transmitters).
8. Set the audio input to 1.5kHz, 0dBm.
9. Adjust RV2 (Mod. Bal.) for a deviation of 5kHz (2.5kHz for narrow band transmitters).
10. Repeat steps 6-9 until balance is achieved.
11. Key the transmitter off.
12. Return JP7 to its correct setting.
13. Carry out the Deviation (section 6.6) and Tone Deviation (section 6.5) alignment procedures.

6.5 Tone Deviation

1. Remove the audio input.
2. Key the transmitter on.
3. Adjust RV3 for the desired deviation in the range 0-1kHz.¹ If sub-tone (CTCSS) coding is not to be used, adjust RV3 fully CCW.

¹ The factory default is 500Hz for wide band (5kHz maximum deviation) and 250Hz for narrow band channels.

6.6 Deviation

1. Set RV4 (Line Level) fully clockwise (CW).
2. Set the audio to 1kHz, 0dBm, on the line input.
3. Key the transmitter on..
4. Adjust RV1 (Set Max. Deviation) for a deviation of 5kHz (2.5kHz for narrow band transmitters).
5. Key the transmitter off.
6. Carry out the Line Input Level alignment procedure (section 6.7)

6.7 Line Input Level

1. Set the audio to 1kHz, 0dBm, on the line input, or use the actual signal to be transmitted.
2. Key the transmitter on.
3. Adjust RV4 (line level) for 60% of system deviation (3kHz or 1.5kHz for narrow band systems).
4. If the test signal is varying, RV4 may be adjusted to produce a level of 234mV RMS or 660mV_{p-p} at the audio voltage test connector pin 6 to pin 1.
5. Key the transmitter off.

6.8 Output Power

1. No audio input is required
2. Key the transmitter on.
3. Adjust RV1 on the power amplifier PCB for the desired power level *at the output connector.*²
4. Key the transmitter off.

² Be sure to set the power below the rated maximum for the model of transmitter. If in doubt, allow 1.5dB cable and connector losses, and assume that the maximum rated power is 15W. This means no more than 10W at the end of a 1m length of test cable. This pessimistic procedure is safe on all models manufactured at the time of writing.

7 SPECIFICATIONS

7.1 Overall Description

The transmitter is a frequency synthesized, narrow band FM unit, normally used to drive a 50 watt amplifier. It can also be used alone in lower power applications. Various models allow 2-25W of output power to be set across a number of UHF frequency bands. All necessary control and 600 Ω line interface circuitry is included.

7.1.1 Channel Capacity

Although most applications are single channel, it can be programmed for up to 100 channels, numbered 0 - 99. This is to provide the capability of programming all channels into all of the transmitters used at a given site. Where this facility is used in conjunction with channel-setting in the rack, exciter modules may be "hot-jockeyed" or used interchangeably. This can be convenient in maintenance situations.

7.1.2 CTCSS

Full EIA sub-tone capability is built into the modules. The CTCSS tone can be programmed for each channel. This means that each channel number can represent a unique RF and tone frequency combination.

7.1.3 Channel Programming

The channel information is stored in non-volatile memory and can be programmed via the front panel test connector using a PC and RF Technology software.

7.1.4 Channel Selection

Channel selection is by eight channel select lines. These are available through the rear panel connector. Internal presetting is also possible. The default (open-circuit) state is to select channel 00.

A BCD active high code applied to the lines selects the required channel. This can be supplied by pre-wiring the rack connector so that each rack position is dedicated to a fixed channel. Alternatively, thumb-wheel switch panels are available.

7.1.5. Microprocessor

A microprocessor is used to control the synthesizer, tone squelch, PTT function and facilitate channel frequency programming. With the standard software, RF Technology modules also provide fault monitoring and reporting.

7.2 Physical Configuration

The transmitter is designed to fit in a 19 inch rack mounted sub-frame. The installed height is 4 RU (178 mm) and the depth is 350 mm. The transmitter is 63.5 mm or two Eclipse modules wide.

7.3 Front Panel Controls, Indicators, and Test Points

7.3.1 Controls

Transmitter Key - Momentary Contact Push Button

Line Input Level - screwdriver adjust multi-turn pot

7.3.2 Indicators

Power ON - Green LED

Tx Indicator - Yellow LED

Fault Indicator - Flashing Red LED

External ALC - Green LED

External Reference - Green LED

7.3.3 Test Points

Line Input - 6 + Ground (pin 1)

Forward Power - 8 + Ground (pin 1)

Reverse Power - 4 + Ground (pin 1)

Tuning Voltage - 9 + Ground (pin 1)

Serial Data (RS-232) - 2 / 3 + Ground (pin 1)

7.4 Electrical Specifications

7.4.1 Power Requirements

Operating Voltage - 10.5 to 16 Vdc with output power reduced below 12 Vdc

Current Drain - 5A Maximum, typically 0.25A Standby

Polarity - Negative Ground

7.4.2 Frequency Range and Channel Spacing

Frequency	25 kHz	12.5 kHz
330-365 MHz	T350C	T350CN
360-380 MHz	T350A	T350AN
375-400 MHz	T350B	T350BN
403-420 MHz	T500A	T500AN
430-450 MHz	T500D	T500DN
450-520 MHz	T500B	T500BN

7.4.3 Frequency Synthesizer Step Size

Step size is 10 / 12.5kHz or 5 / 6.25kHz, fixed, depending upon model

7.4.4 Frequency Stability

±1 ppm over 0 to +60 C, standard

±1ppm over -20 to +60 C, optional

7.4.5 Number of Channels

100, numbered 00 - 99

7.4.6 Antenna Impedance

50Ω

7.4.7 Output power

Preset for 2-15 or 2-25W depending upon model

7.4.8 Transmit Duty Cycle

100% to 40C, de-rating to zero at 60C.
100% to 5000ft altitude, de-rating to zero at 15,000ft.

7.4.9 Spurious and Harmonics

Less than 0.25~W

7.4.10 Carrier and Modulation Attack Time

Less than 20ms. Certain models have RF envelope attack and decay times controlled in the range $200 \sim s < t_{r/f} < 2ms$ according to regulatory requirements.

7.4.11 Modulation

Type - Two point direct FM with optional pre-emphasis

Frequency Response - ± 1 dB of the selected characteristic from 300 - 3000 Hz

Maximum Deviation - Maximum deviation preset to 2.5 or 5 kHz

7.4.12 Distortion

Modulation distortion is less than 3% at 1 kHz and 60% of rated system deviation.

7.4.13 Residual Modulation and Noise

The residual modulation and noise in the range 300 - 3000 Hz is typically less than -50dB referenced to rated system deviation.

7.4.14 600h Line Input Sensitivity

Adjustable from -30 to +10 dBm for rated deviation

7.4.15 HI-Z Input

Impedance - 10K Ω Nominal, balanced input

Input Level - 25mV to 1V RMS

7.4.16 Test Microphone Input

200 Ω dynamic, with PTT

7.4.17 External Tone Input

Compatible with R500 tone output

7.4.18 External ALC Input

Output will be reduced 20dB by pulling the input down to below 1V. (Typically more than 40dB attenuation is available.) The input impedance is $\cong 10\text{k}\Omega$, internally pulled up to rail.

The external ALC input can be connected to the power control circuit in Eclipse external power amplifiers.

7.4.19 T/R Relay Driver

An open collector transistor output is provided to operate an antenna change over relay or solid state switch. The transistor can sink up to 250mA.

7.4.20 Channel Select Input / Output

Coding - 8 lines, BCD coded 00 - 99

Logic Input Levels - Low for <1.5V, High for >3.5V

Internal 10K pull down resistors select channel 00 when all inputs are O/C.

7.4.21 DC Remote Keying

An opto-coupler input is provided to enable dc loop keying over balanced lines or local connections. The circuit can be connected to operate through the 600 Ω line or through a separate isolated pair.

7.4.22 Programmable No-Tone Period

A No-Tone period can be appended to the end of each transmission to aid in eliminating squelch tail noise which may be heard in mobiles with slow turn off decoders. The No-Tone period can be set from 0--5 seconds in 0.1 second increments. The No Tone period operates in addition to the reverse phase burst at the end of each transmission.³

7.4.23 Firmware Timers

The controller firmware includes some programmable timer functions.

Repeater Hang Time - A short delay or "Hang Time" can be programmed to be added to the end of transmissions. This is usually used in talk through repeater applications to prevent the repeater from dropping out between mobile transmissions. The Hang Time can be individually set on each channel for 0 - 15 seconds.

Time Out Timer - A time-out or transmission time limit can be programmed to automatically turn the transmitter off. The time limit can be set from 0-254 minutes in increments of one minute. The timer is automatically reset when the PTT input is released.

7.4.24 CTCSS

CTCSS tones can be provided by an internal encoder or by an external source connected to the external tone input. The internal CTCSS encoding is provided by a subassembly PCB module. This provides programmable encoding of all EIA tones. Some models encode certain extra tones.

Tone frequencies are given in table 4.

7.5 Connectors

7.5.1 Antenna Connector

Type N Female Mounted on the module rear panel

³ The reverse phase burst is usually sufficient to eliminate squelch tail noise in higher-quality mobiles

Frequency	EIA Number
No Tone	
67.0	A1
69.4	
71.9	B1
74.4	C1
77.0	A2
79.7	C2
82.5	B2
85.4	C3
88.5	A3
91.5	C4
94.8	B3
97.4	
100.0	A4
103.5	B4
107.2	A5
110.9	B5
114.8	A6
118.8	B6
123.0	A7
127.3	B7
131.8	A8
136.5	B8
141.3	A9
146.2	B9
151.4	A10
156.7	B10
159.8	
162.2	A11
165.5	
167.9	B11
171.3	
173.8	A12
177.3	
179.9	B12
183.5	
186.2	A13
189.9	
192.8	B13
196.6	
199.5	
203.5	A14
206.5	
210.7	B14
218.1	A15
225.7	B15
229.1	
233.6	A16
241.8	B16
250.3	A17
254.1	

Table 4: Tone Squelch Frequencies
--

7.5.2 Power & I/O Connector

25-pin “D” Male Mounted on the rear panel

7.5.3 Test Connector

9-pin “D” Female mounted on the front panel

A Engineering Diagrams

Most Eclipse transmitter modules contain two PCBs, a motherboard with the control and signal generation circuitry (the exciter board), and an RF Power Amplifier board. Certain models are equipped with optional functions on piggyback PCBs atop the exciter motherboard. The exciter PCB typically has a few components whose values vary from model to model depending upon operating frequency and local regulatory constraints. The RF PA PCB varies from model to model but to a greater extent. At least two different PCB layouts, and numerous variations, exist. This manual presents the circuits and parts lists for two representative variants. When ordering spare parts be sure to specify the model exactly, in case the part you require is different in value from that specified in this manual.

Older models (predating this manual) may not be covered by this manual. However, advances are evolutionary, and the information in this manual will be sufficient in most cases to permit understanding and servicing of all models, past and present.

Versions of more detailed circuit schematics, printed on A3 paper, may be inserted or bound with this manual towards the end. It is sometimes easier to work with these fold-out diagrams because of their larger format. In case the inserts / fold-outs are missing or damaged, the reader is advised that information in the figures included with the text should be identical.

A.1 Block Diagram

Figure 1 shows the block signal flow diagram.

A.2 Circuit Diagrams

Figure 2 shows the detailed circuit diagram with component numbers and values for the main (exciter) PCB. Figure 3 shows the detailed circuit diagram with component numbers and values for the higher-power PA variation. Figure 4 shows the detailed circuit diagram with component numbers and values for the lower-power PA variation.

A.3 Component Overlay Diagrams

Figure 5 shows the PCB overlay guide with component positions for the main (exciter) PCB. Figure 6 shows the detailed circuit diagram with component numbers and values for the higher-power PA variation. Figure 7 shows the detailed circuit diagram with component numbers and values for the lower power PA variation.

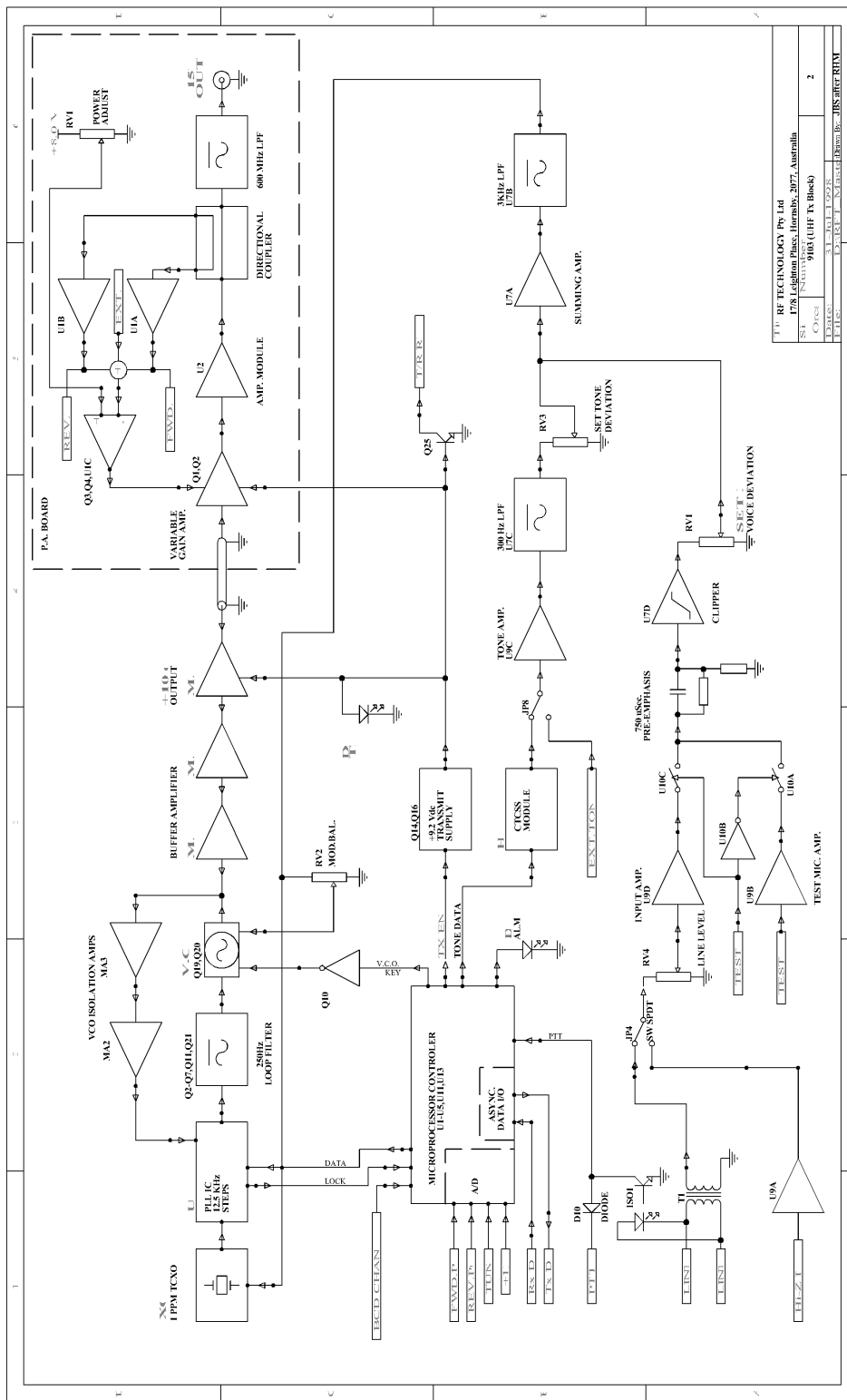

Figure 1: The block circuit diagram

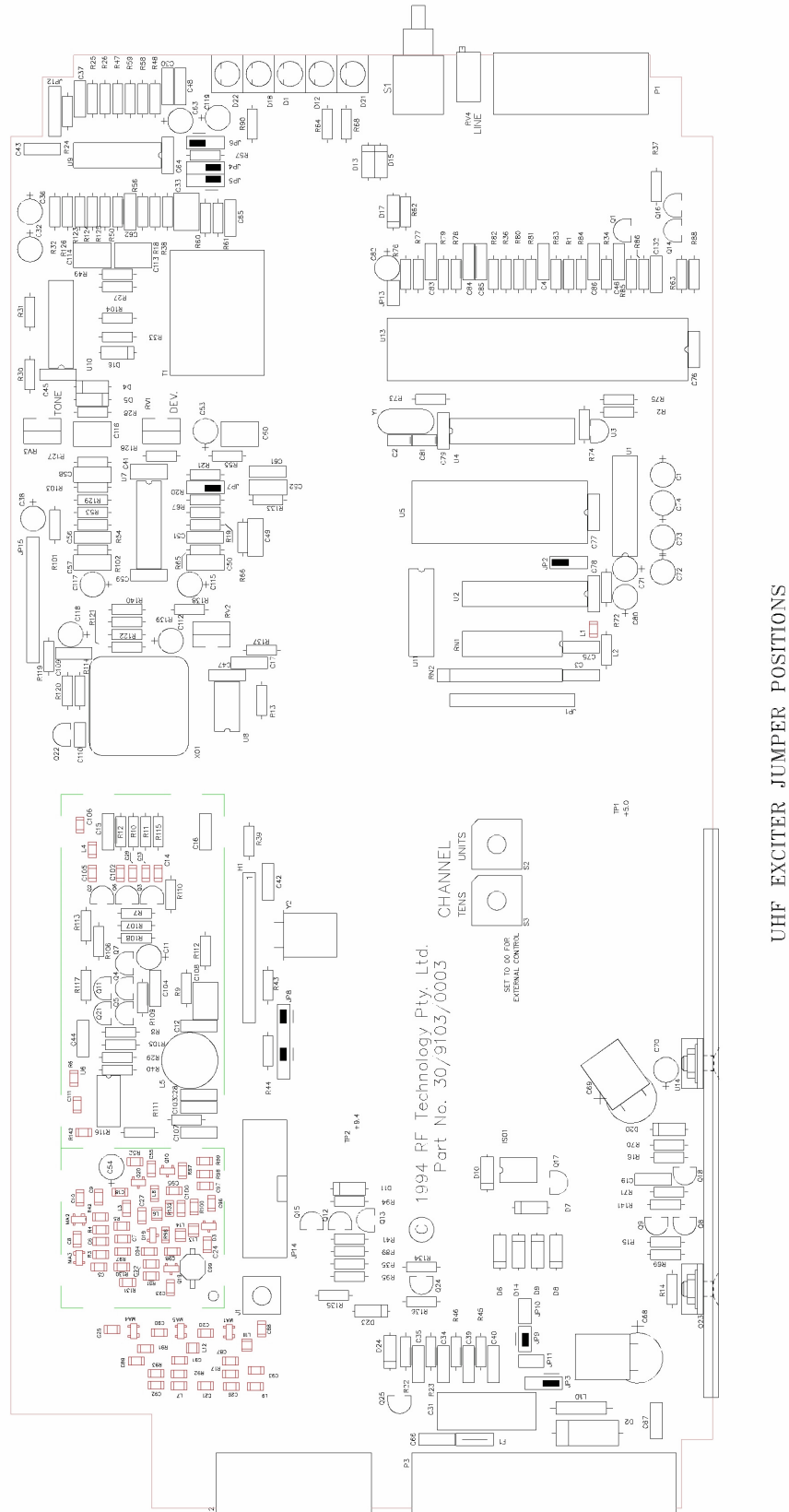

Figure 2: The main board component overlay diagram.

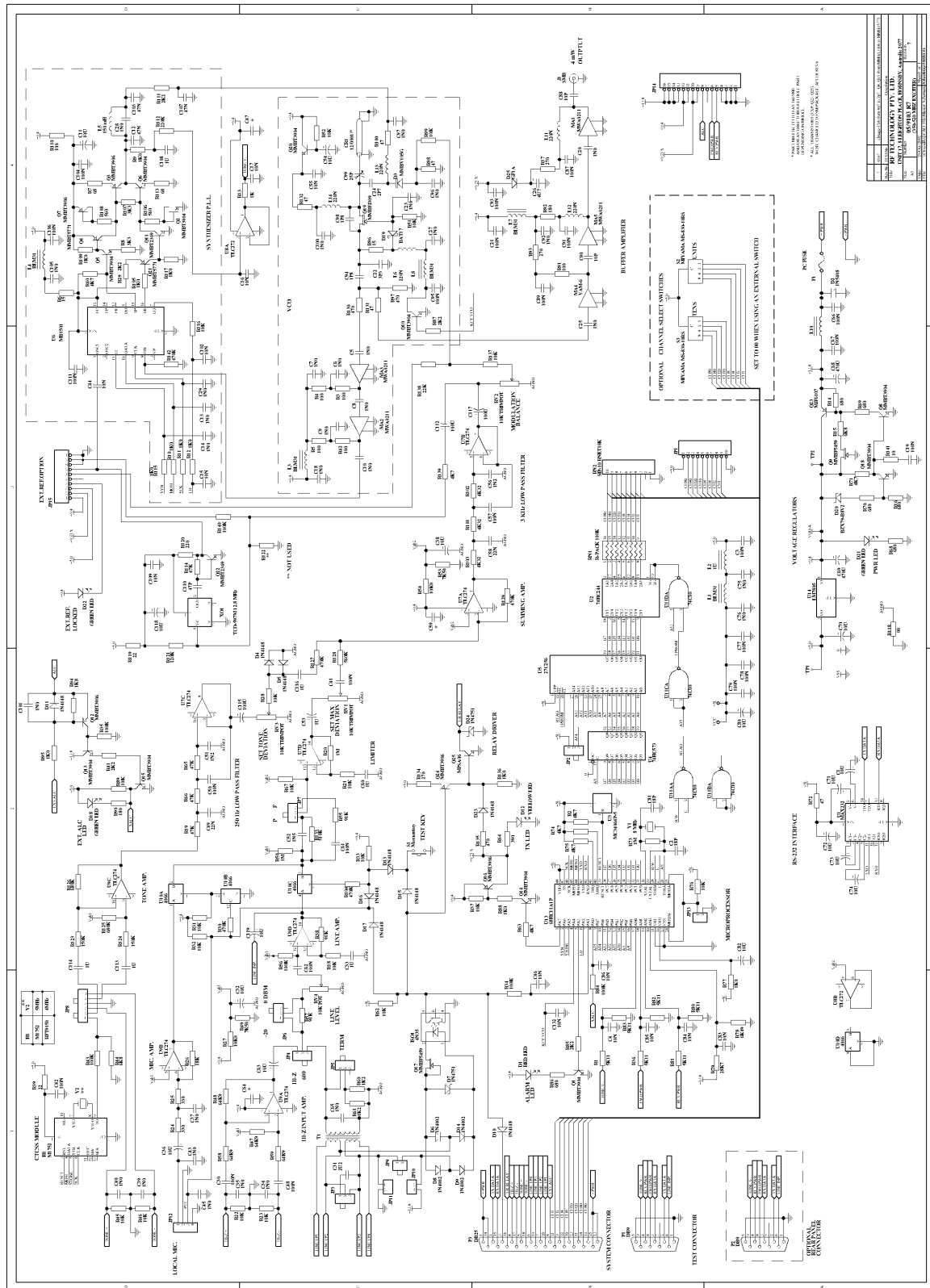

Figure 3: The component circuit diagram of the 9103 UHF Transmitter.

This Page Is Blank Intentionally

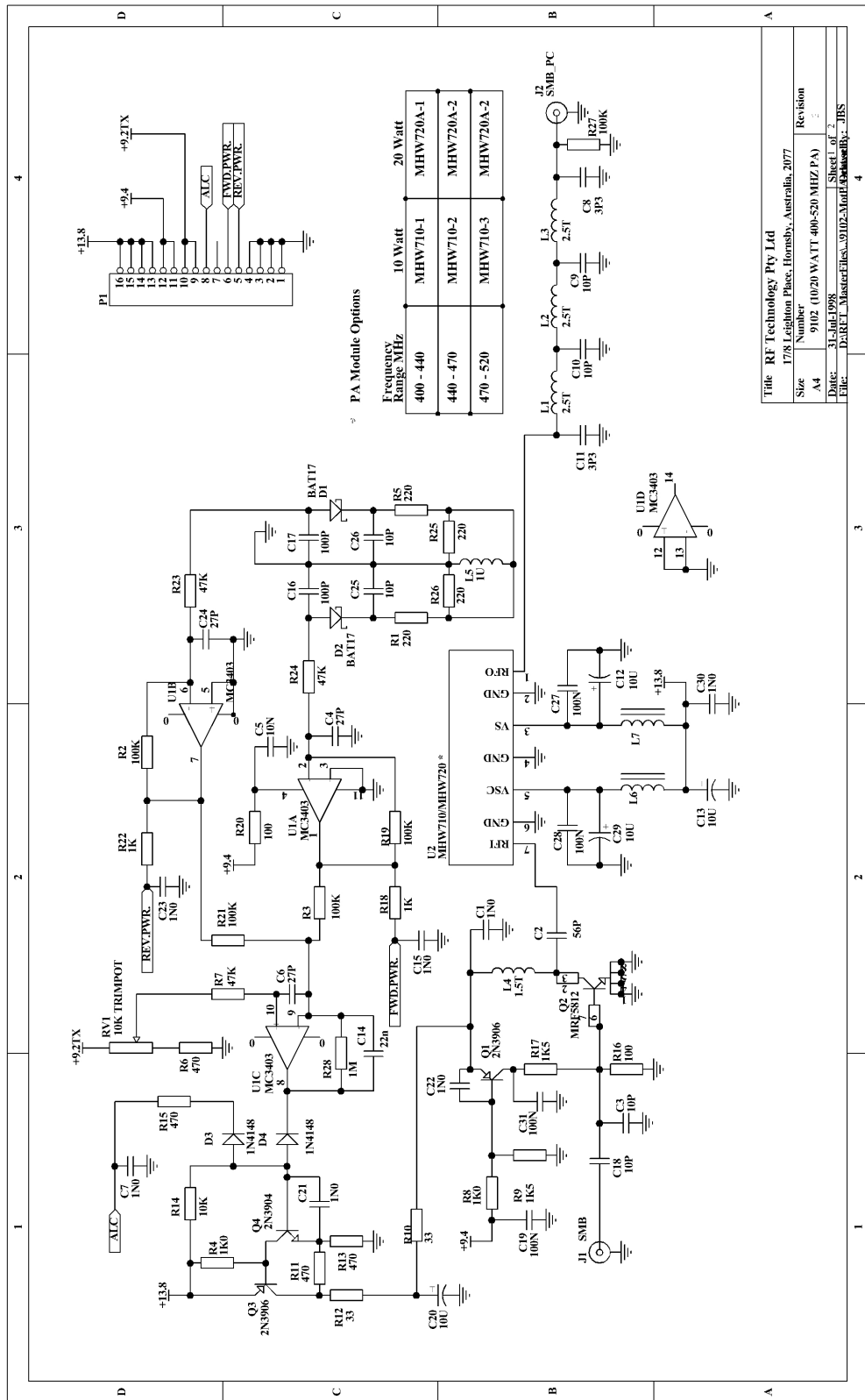

Figure 4: The component circuit diagram of the 9102 UHF PA.

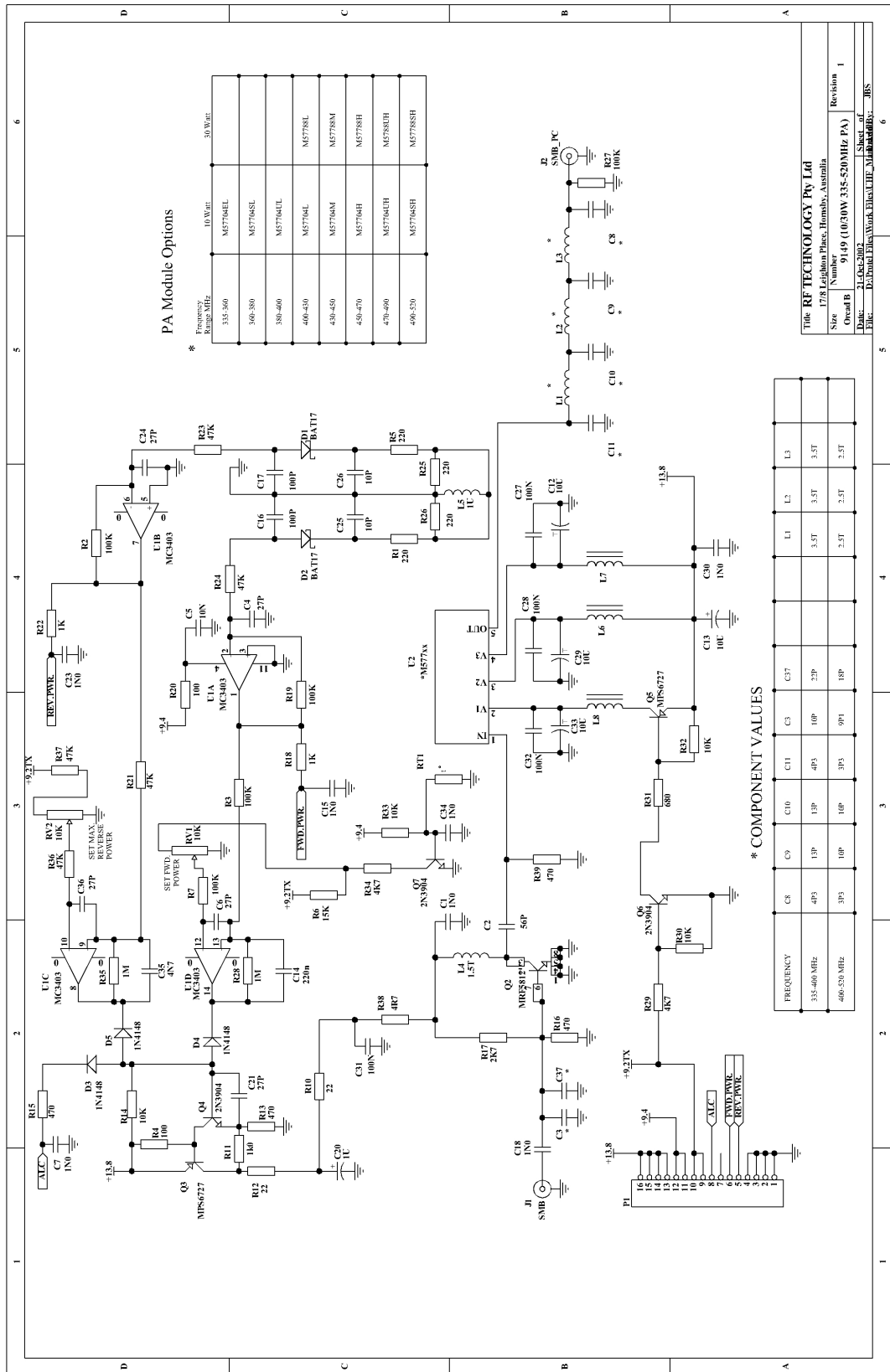

Figure 5: The component circuit diagram of the 9128/9149 UHF PA.

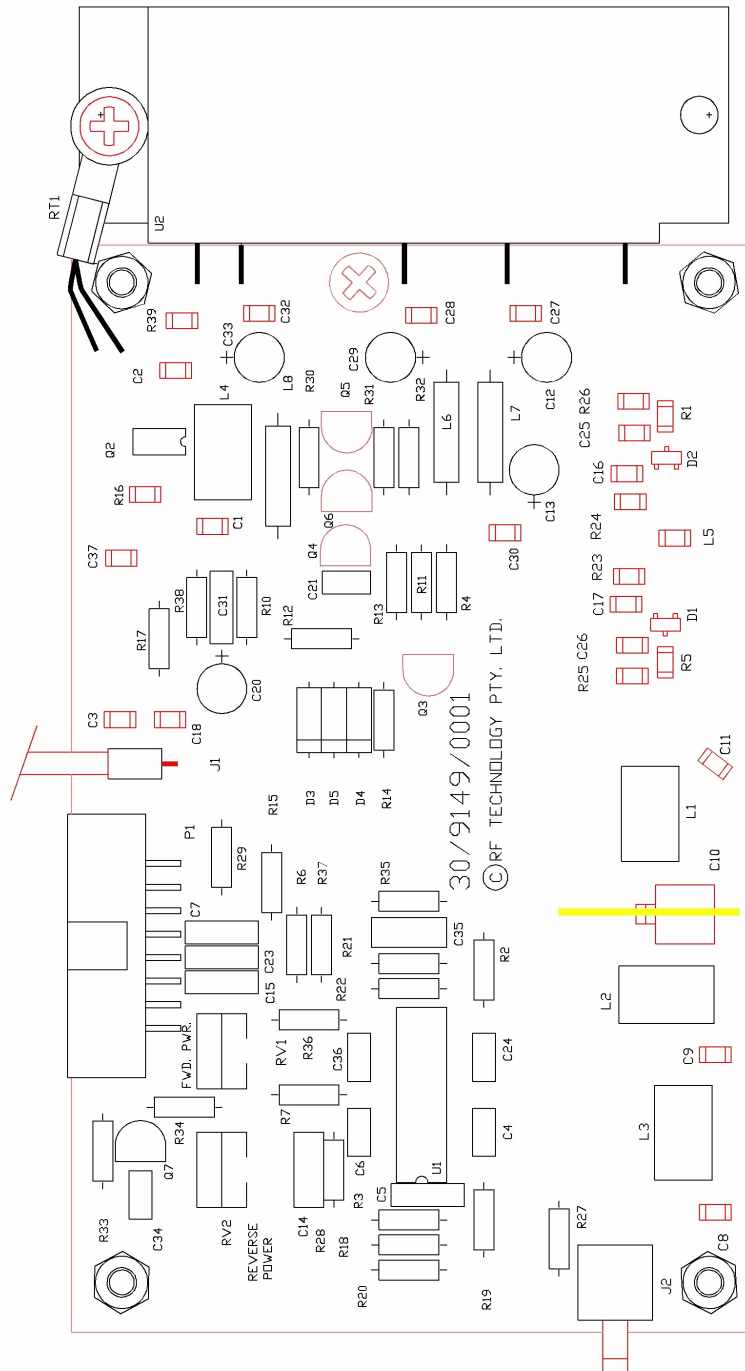

Figure 6: The component overlay diagram for the higher-power PA board.

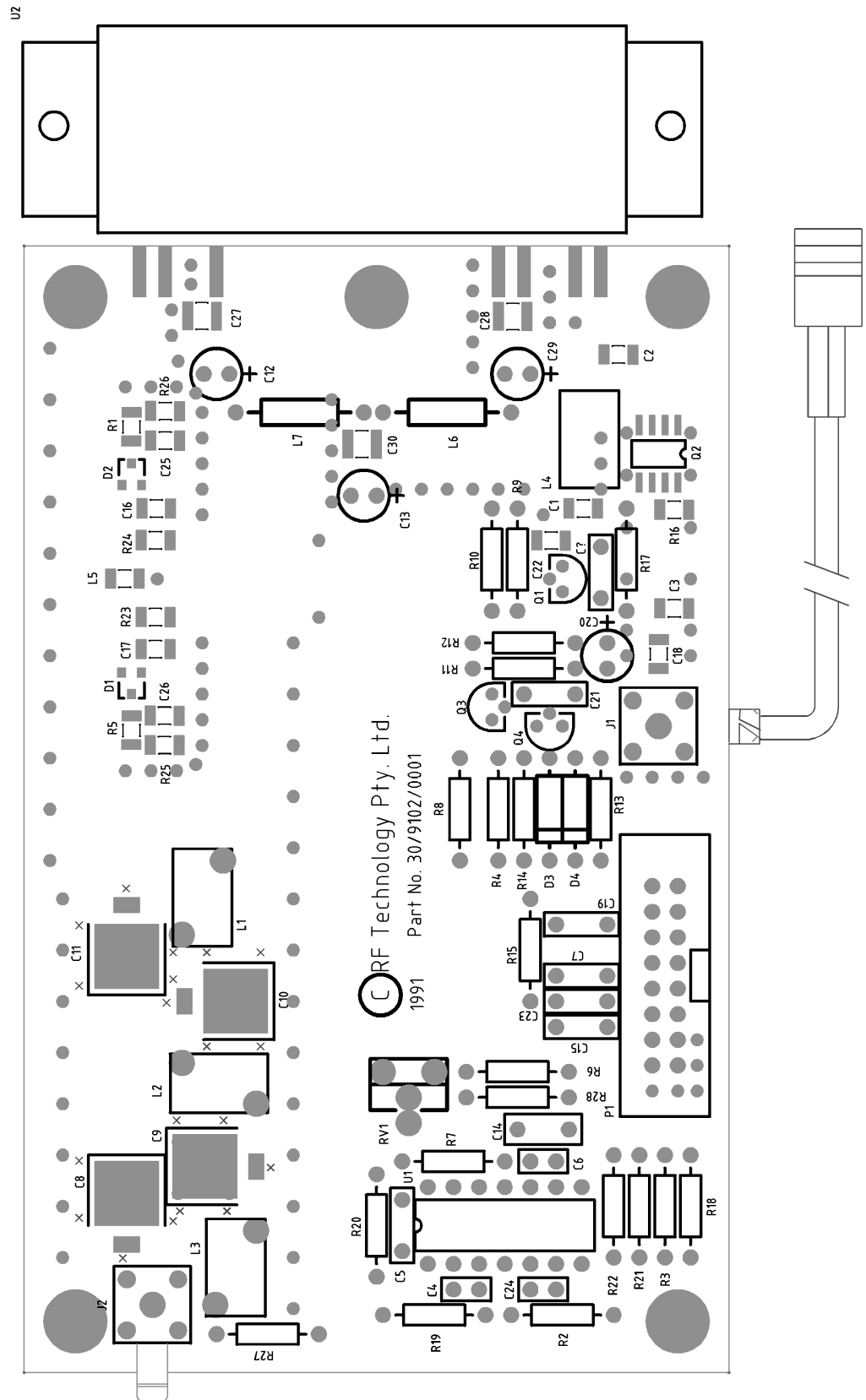

Figure 7: The component overlay diagram for the lower-power PA board

B T350/T500 Parts List (for PCB-30/9103/xxxx)**Main PCB Assembly Parts**

<u>Ref.</u>	<u>Description</u>	<u>Part Number</u>
C1	Capacitor 10U 35V Rad Electro	41/2001/010U
C2	Capacitor 18P 2% 100V NPO Rad.1	45/2680/018P
C3	Capacitor 100N 10% 50V X7R Rad.2	46/2001/100N
C4	Capacitor 10N 10% 50V X7R Rad.2	46/2001/010N
C5	Capacitor 1N0 5% 63V NPO SM1206	46/3300/01N0
C6	Capacitor 1N0 5% 63V NPO SM1206	46/3300/01N0
C7	Capacitor 1N0 5% 63V NPO SM1206	46/3300/01N0
C8	Capacitor 1N0 5% 63V NPO SM1206	46/3300/01N0
C9	Capacitor 1N0 5% 63V NPO SM1206	46/3300/01N0
C10	Capacitor 1N0 5% 63V NPO SM1206	46/3300/01N0
C11	Capacitor 10U 35V Rad Electro	41/2001/010U
C12	Capacitor 47N 20% 50V X7R Rad.2	46/2001/047N
C13	Capacitor 1N0 5% 63V NPO SM1206	46/3300/01N0
C14	Capacitor 1N0 5% 63V NPO SM1206	46/3300/01N0
C15	Capacitor 10N 10% 50V X7R Rad.2	46/2001/010N
C16	Capacitor 10N 10% 50V X7R Rad.2	46/2001/010N
C17	Capacitor 10N 10% 50V X7R Rad.2	46/2001/010N
C18	Capacitor 1N0 5% 63V NPO SM1206	46/3300/01N0
C19	Capacitor 100N 10% 50V X7R Rad.2	46/2001/100N
C20	Capacitor 1N0 5% 63V NPO SM1206	46/3300/01N0
C21	Capacitor 100N 10% 63V X7R 1206	46/3310/100N
C22	Capacitor 3P3 5% 63V NPO SM1206	46/3300/03P3
C23	Capacitor 1N0 5% 63V NPO SM1206	46/3300/01N0
C24	Capacitor 2P7 5% 63V NPO SM1206	46/3300/02P7
C25	Capacitor 1N0 5% 63V NPO SM1206	46/3300/01N0
C26	Capacitor, 6.8U SMD Tantalum	42/3009/06U8
C27	Capacitor 1N0 5% 63V NPO SM1206	46/3300/01N0
C28	Capacitor 1N0 5% 100V NPO Rad.2	46/2000/01N0
C29	Capacitor 1N0 5% 63V NPO SM1206	46/3300/01N0
C30	Capacitor 100N 10% 50V X7R Rad.2	46/2001/100N
C31	Capacitor 2U2 10% 100V MKT Rad.2	47/2010/02U2
C32	Capacitor 10U 35V Rad Electro	41/2001/010U
C33	Capacitor 1U0 10% 63V MKT Rad.2	47/2007/01U0
C34	Capacitor 1N0 5% 100V NPO Rad.2	46/2000/01N0
C35	Capacitor 1N0 5% 100V NPO Rad.2	46/2000/01N0
C36	Capacitor 10U 35V Rad Electro	41/2001/010U
C37	Capacitor 1N0 5% 100V NPO Rad.2	46/2000/01N0
C38	Capacitor 10U 35V Rad Electro	41/2001/010U
C39	Capacitor 1N0 5% 100V NPO Rad.2	46/2000/01N0
C40	Capacitor 1N0 5% 100V NPO Rad.2	46/2000/01N0
C41	Capacitor 100N 5% 50V MKT Rad.2	47/2007/100N
C42	Capacitor 100N 10% 50V X7R Rad.2	46/2001/100N
C43	Capacitor 1N0 5% 100V NPO Rad.2	46/2000/01N0
C44	Capacitor 10N 10% 50V X7R Rad.2	46/2001/010N
C45	Capacitor 1N0 5% 100V NPO Rad.2	46/2000/01N0
C46	Capacitor 10N 10% 50V X7R Rad.2	46/2001/010N
C47s	Capacitor 1N0 5% 63V NPO SM1206	46/3300/01N0
C48	Capacitor 100N 10% 50V X7R Rad.2	46/2001/100N
C49	Capacitor 22N 5% 63V MKT Rad.2	47/2010/022N
C50	Capacitor 100N 5% 50V MKT Rad.2	47/2007/100N
C51	Capacitor 1N2 5% NPO Rad.2	46/2000/01N2
C52	Capacitor 1N5 10% 50V COG Rad.2	46/2000/01N5
C53	Capacitor 1U 35V Rad Electro	41/2001/001U
C54	Capacitor 10U 35V Rad Electro	41/2001/010U
C55	Capacitor 10N 10% 63V X7R SM1206	46/3310/010N

<u>Ref.</u>	<u>Description</u>	<u>Part Number</u>
C56	Capacitor 1N2 5% NPO Rad.2	46/2000/01N2
C57	Capacitor 100N 5% 50V MKT Rad.2	47/2007/100N
C58	Capacitor 22N 5% 63V MKT Rad.2	47/2010/022N
C59s	Capacitor 1N0 5% 63V NPO SM1206	46/3300/01N0
C60	Capacitor 1UO 10% 63V MKT Rad.2	47/2007/01UO
C61	Capacitor 100N 10% 50V X7R Rad.2	46/2001/100N
C62	Capacitor 100N 10% 50V X7R Rad.2	46/2001/100N
C63	Capacitor 10U 35V Rad Electro	41/2001/010U
C64s	Capacitor 1N0 5% 63V NPO SM1206	46/3300/01N0
C65	Capacitor 1N0 5% 100V NPO Rad.2	46/2000/01N0
C66	Capacitor 100N 10% 50V X7R Rad.2	46/2001/100N
C67	Capacitor 100N 10% 50V X7R Rad.2	46/2001/100N
C68	Capacitor 470U 25V RB Electro	41/2001/470U
C69	Capacitor 470U 25V RB Electro	41/2001/470U
C70	Capacitor 10U 35V Rad Electro	41/2001/010U
C71	Capacitor 10U 35V Rad Electro	41/2001/010U
C72	Capacitor 10U 35V Rad Electro	41/2001/010U
C73	Capacitor 10U 35V Rad Electro	41/2001/010U
C74	Capacitor 10U 35V Rad Electro	41/2001/010U
C75	Capacitor 1N0 5% 100V NPO Rad.2	46/2000/01N0
C76	Capacitor 1N0 5% 100V NPO Rad.2	46/2000/01N0
C77	Capacitor 100N 10% 50V X7R Rad.2	46/2001/100N
C78	Capacitor 100N 10% 50V X7R Rad.2	46/2001/100N
C79	Capacitor 100N 10% 50V X7R Rad.2	46/2001/100N
C80	Capacitor 10U 35V Rad Electro	41/2001/010U
C81	Capacitor 18P 2% 100V NPO Rad.1	45/2680/018P
C82	Capacitor 10U 35V Rad Electro	41/2001/010U
C83	Capacitor 10N 10% 50V X7R Rad.2	46/2001/010N
C84	Capacitor 10N 10% 50V X7R Rad.2	46/2001/010N
C85	Capacitor 10N 10% 50V X7R Rad.2	46/2001/010N
C86	Capacitor 10N 10% 50V X7R Rad.2	46/2001/010N
C87	Capacitor 100N 10% 63V X7R 1206	46/3310/100N
C88	Capacitor 10P 5% 63V NPO SM1206	46/3300/010P
C89	Capacitor 100N 10% 63V X7R 1206	46/3310/100N
C90	Capacitor 10P 5% 63V NPO SM1206	46/3300/010P
C91	Capacitor 100N 10% 63V X7R 1206	46/3310/100N
C92	Capacitor 1N0 5% 63V NPO SM1206	46/3300/01N0
C93	Capacitor 100N 10% 63V X7R 1206	46/3310/100N
C94	Capacitor 1P8 5% 63V NPO SM1206	46/3300/01P8
C95	Capacitor 100N 10% 63V X7R 1206	46/3310/100N
C96	Capacitor 1N0 5% 63V NPO SM1206	46/3300/01N0
C97	Capacitor 1N0 5% 63V NPO SM1206	46/3300/01N0
C98	Capacitor 1P8 5% 63V NPO SM1206	46/3300/01P8
C99	Capacitor Trim 5-25P	49/3002/025P
C100	Capacitor 1N0 5% 63V NPO SM1206	46/3300/01N0
C101	Capacitor 1N0 5% 63V NPO SM1206	46/3300/01N0
C102	Capacitor 10N 10% 63V X7R 1206	46/3310/010N
C103	Capacitor 47N 20% 50V X7R Rad.2	46/2001/047N
C104	Capacitor 100N 10% 50V X7R Rad.2	46/2001/100N
C105	Capacitor 1N0 5% 63V NPO SM1206	46/3300/01N0
C106	Capacitor 100N 10% 63V X7R 1206	46/3310/100N
C107	Capacitor 47N 20% 50V X7R Rad.2	46/2001/047N
C108	Capacitor 1UO 10% 63V MKT Rad.2	47/2007/01UO
C109	Capacitor 10N 10% 50V X7R Rad.2	46/2001/010N
C110	Capacitor 47P 2% 100V NPO Rad.1	45/2680/047P
C111	Capacitor 100N 10% 63V X7R 1206	46/3310/100N
C112	Capacitor 100U 25V RB Electro	41/1025/100U
C113	Capacitor 1UO 10% 63V MKT Rad.2	47/2007/01UO

Ref.	Description	Part Number
C114	Capacitor 1UO 10% 63V MKT Rad.2	47/2007/01UO
C115	Capacitor 100U 25V RB Electro	41/1025/100U
C116	Capacitor 1UO 10% 63V MKT Rad.2	47/2007/01UO
C117	Capacitor 100U 25V RB Electro	41/1025/100U
C118	Capacitor 10U 35V Rad Electro	41/2001/010U
C119	Capacitor 10U 35V Rad Electro	41/2001/010U
C132	Capacitor 10N 10% 50V X7R Rad.2	46/2001/010N
D1	Diode LED Red T1 3/4	21/1010/LEDR
D2	Diode 3Amplifier 1KV Rectifier	21/1080/5408
D3	Diode VCapacitor MMBV105G SOT23	21/3060/105G
D4	Diode Silicon 1N4148	21/1010/4148
D5	Diode Silicon 1N4148	21/1010/4148
D6	Diode Silicon GP	21/1010/4002
D7	Diode Zen 1N4751 30V 1W AXIAL	21/1040/4751
D8	Diode Silicon GP	21/1010/4002
D9	Diode Silicon GP	21/1010/4002
D10	Diode Silicon 1N4148	21/1010/4148
D11	Diode Silicon 1N4148	21/1010/4148
D12	Diode LED Yellow T1 3/4	21/1010/LEDY
D13	Diode Silicon 1N4148	21/1010/4148
D14	Diode Silicon GP	21/1010/4002
D15	Diode Silicon 1N4148	21/1010/4148
D16	Diode Silicon 1N4148	21/1010/4148
D17	Diode Silicon 1N4148	21/1010/4148
D18	Diode LED Green T1 3/4	21/1010/LEDG
D19	Diode Schottkey BAT17 SOT23	21/3030/0017
D20	Diode 8V2 Zener	21/1040/B8V2
D21	Diode LED Green T1 3/4	21/1010/LEDG
D22	Diode LED Green T1 3/4	21/1010/LEDG
D23	Diode Silicon 1N4148	21/1010/4148
D24	Diode Zen 1N4751 30V 1W AXIAL	21/1040/4751
D25(L9)	SMD Diode, 100ma 50v	21/3009/AS85
H1	Hybred CTCSS	13/9150/0002
ISO1	IC Opto-Isolator 4N33	25/1010/4N33
J1	Connector Coax SKT SMB Vertical PCB	35/2004/0001
JP2	Connector 3Way Header	35/2501/0003
JP3	Connector 3Way Header	35/2501/0003
JP4	Connector 3Way Header	35/2501/0003
JP5	Connector 3Way Header	35/2501/0003
JP6	Connector 3Way Header	35/2501/0003
JP7	Connector 3Way Header	35/2501/0003
JP8	Connector 6Way Header	35/2501/0006
JP9	Connector 2Way Header	35/2501/0002
JP10	Connector 2Way Header	35/2501/0002
JP11	Connector 2Way Header	35/2501/0002
JP13	Connector 2Way Header	35/2501/0002
JP14	Connector 16Way Shr'd Header	35/2502/0016
JP15	Connector 10Way Header	35/2501/0010
L1	Ferrite Bead SMD	37/3321/LM31
L2	Inductor 1uH Axial	37/2021/001U
L3	Ferrite Bead SMD	37/3321/LM31
L4	Ferrite Bead SMD	37/3321/LM31
L5	Inductor 150mH 10RBH	37/2021/1RBH
L6	Inductor 220N 10% Choke SM1206	37/3320/220N
L7	Ferrite Bead SMD	37/3321/LM31
L8	Ferrite Bead SMD	37/3321/LM31
L10	Inductor 6 Hole Ferrite RFC	37/1021/0001
L11	Inductor 220N 10% Choke SM1206	37/3320/220N
L12	Inductor 220N 10% Choke SM1206	37/3320/220N
L13	Inductor 220N 10% Choke SM1206	37/3320/220N

<u>Ref.</u>	<u>Description</u>	<u>Part Number</u>
L14	Inductor 220N 10% Choke SM1206	37/3320/220N
MA1	Amplifier MMIC MWA0311L SOT143	24/3010/0311
MA2	Amplifier MMIC MWA0311L SOT143	24/3010/0311
MA3	Amplifier MMIC MWA0311L SOT143	24/3010/0311
MA4	Amplifier MMIC VAM-6 SOT143	24/3010/VAM6
MA5	Amplifier MMIC MWA0311L SOT143	24/3010/0311
P1	Filter D RT AGL 9W F Ferrite	35/5012/009F
P3	Filter D RT AGL 25W M Ferrite	35/5012/025M
Q1	Transistor GP NPN MMBT3904 SOT23	27/3020/3904
Q2	Transistor GP NPN MMBT3904 SOT23	27/3020/3904
Q3	Transistor GP PNP MMBT3906 SOT23	27/3010/3906
Q4	Fast Switching SMD Transistor	27/3010/5771
Q5	Transistor GP NPN MMBT3904 SOT23	27/3020/3904
Q6	Transistor GP NPN MMBT3904 SOT23	27/3020/3904
Q7	Transistor GP PNP MMBT3906 SOT23	27/3010/3906
Q8	Transistor GP NPN MMBT3904 SOT23	27/3020/3904
Q9	SMD FET NJ MMBF5459LT1 SOT23	27/3020/5459
Q10	Transistor GP NPN MMBT2369 SOT23	27/3020/2369
Q11	Transistor GP NPN MMBT2369 SOT23	27/3010/2369
Q12	Transistor GP PNP MMBT3906 SOT23	27/3010/3906
Q13	Transistor GP NPN MMBT3904 SOT23	27/3020/3904
Q14	Transistor GP NPN MMBT3904 SOT23	27/3020/3904
Q15	Transistor GP NPN MMBT3904 SOT23	27/3020/3904
Q16	Transistor GP PNP MMBT3906 SOT23	27/3010/3906
Q17	SMD FET NJ MMBF5459LT1 SOT23	27/3020/5459
Q18	Transistor GP NPN MMBT3904 SOT23	27/3020/3904
Q19	FET NJ MMBFJ309 SOT23	27/3030/J309
Q20	Transistor GP NPN MMBT3904 SOT23	27/3020/3904
Q21	Fast Switching SMD Transistor	27/3010/5771
Q22	Transistor GP NPN MMBT2369 SOT23	27/3020/2369
Q23	Transistor PNP MJF6107 TO220	27/2010/6107
Q24	Transistor GP PNP MMBT3906 SOT23	27/3010/3906
Q25	Transistor NPN GP MPSA06 TO92	27/2010/PA06
R1	Resistor 5K11 1% 0.25W Axial	51/1010/5K11
R2	Resistor 4K7 5% 0.25W Axial	51/1040/04K7
R3	Resistor 100 5% 0.25W SM1206	51/3380/0100
R4	Resistor 100 5% 0.25W SM1206	51/3380/0100
R5	Resistor 100 5% 0.25W SM1206	51/3380/0100
R6	Resistor 15R 5% 0.25W SM1206	51/3380/0015
R7	Resistor 68 5% 0.25W Axial	51/1040/0068
R8	Resistor 3K3 5% 0.25W Axial	51/1040/03K3
R9	Resistor 1K0 5% 0.25W Axial	51/1040/01K0
R10	Resistor 1K0 5% 0.25W Axial	51/1040/01K0
R11	Resistor 1K0 5% 0.25W Axial	51/1040/01K0
R12	Resistor 1K0 5% 0.25W Axial	51/1040/01K0
R13	Resistor 1K0 5% 0.25W Axial	51/1040/01K0
R14	Resistor 680 5% 0.25W Axial	51/1040/0680
R15	Resistor 6K8 5% 0.25W Axial	51/1040/06K8
R16	Resistor 680 5% 0.25W Axial	51/1040/0680
R17	Resistor 270 5% 0.25W SM1206	51/3380/0270
R18	Resistor 10K 5% 0.25W Axial	51/1040/010K
R19	Resistor 47K 5% 0.25W Axial	51/1040/047K
R20	Resistor 1M0 5% 0.25W Axial	51/1040/01M0
R21	Resistor 10K 5% 0.25W Axial	51/1040/010K
R22	Resistor 10K 5% 0.25W Axial	51/1040/010K
R23	Resistor 10K 5% 0.25W Axial	51/1040/010K
R24	Resistor 330 5% 0.25W Axial	51/1040/0330
R25	Resistor 330 5% 0.25W Axial	51/1040/0330
R26	Resistor 18K 5% 0.25W Axial	51/1040/018K
R27	Resistor 10K0 1% 0.25W Axial	51/1010/010K

<u>Ref.</u>	<u>Description</u>	<u>Part Number</u>
R28	Resistor 10K 5% 0.25W Axial	51/1040/010K
R29	Resistor 2K2 5% 0.25W Axial	51/1040/02K2
R30	Resistor 470K 5% 0.25W Axial	51/1040/470K
R31	Resistor 10K 5% 0.25W Axial	51/1040/010K
R32	Resistor 10K 5% 0.25W Axial	51/1040/010K
R33	Resistor 10K 5% 0.25W Axial	51/1040/010K
R34	Resistor 100K 5% 0.25W Axial	51/1040/100K
R35	Resistor 100K 5% 0.25W Axial	51/1040/100K
R36	Resistor 5K11 1% 0.25W Axial	51/1010/5K11
R37	Resistor 10K 5% 0.25W Axial	51/1040/010K
R38	Resistor 91K 5% 0.25W Axial	51/1040/091K
R39	Resistor 22 5% 0.25W Axial	51/1040/0022
R40	Resistor 4K7 5% 0.25W Axial	51/1040/04K7
R41	Resistor 2K2 5% 0.25W Axial	51/1040/02K2
R42	Resistor 100 5% 0.25W SM1206	51/3380/0100
R43	Resistor 100K 5% 0.25W Axial	51/1040/100K
R44	Resistor 6K8 5% 0.25W Axial	51/1040/06K8
R45	Resistor 10K 5% 0.25W Axial	51/1040/010K
R46	Resistor 10K 5% 0.25W Axial	51/1040/010K
R47	Resistor 64K9 1% 0.25W Axial	51/1010/64K9
R48	Resistor 64K9 1% 0.25W Axial	51/1010/64K9
R49	Resistor 7K50 1% 0.25W Axial	51/1010/07K5
R50	Resistor 1M0 5% 0.25W Axial	51/1040/01M0
R51	Resistor 10K 5% 0.25W SM1206	51/3380/010K
R52	Resistor 10K 5% 0.25W SM1206	51/3380/010K
R53	Resistor 7K50 1% 0.25W Axial	51/1010/07K5
R54	Resistor 10K0 1% 0.25W Axial	51/1010/010K
R55	Resistor 91K 5% 0.25W Axial	51/1040/091K
R56	Resistor 100K 5% 0.25W Axial	51/1040/100K
R57	Resistor 91K 5% 0.25W Axial	51/1040/091K
R58	Resistor 64K9 1% 0.25W Axial	51/1010/64K9
R59	Resistor 64K9 1% 0.25W Axial	51/1010/64K9
R60	Resistor 1K2 5% 0.25W Axial	51/1040/01K2
R61	Resistor 1K2 5% 0.25W Axial	51/1040/01K2
R62	Resistor 10K 5% 0.25W Axial	51/1040/010K
R63	Resistor 4K7 5% 0.25W Axial	51/1040/04K7
R64	Resistor 390 5% 0.25W Axial	51/1040/0390
R65	Resistor 47K 5% 0.25W Axial	51/1040/047K
R66	Resistor 47K 5% 0.25W Axial	51/1040/047K
R67	Resistor 10K 5% 0.25W Axial	51/1040/010K
R68	Resistor 680 5% 0.25W Axial	51/1040/0680
R69	Resistor 1K 5% 0.25W Axial	51/1040/01K0
R70	Resistor 680 5% 0.25W Axial	51/1040/0680
R71	Resistor 4K7 5% 0.25W Axial	51/1040/04K7
R72	Resistor 47 5% 0.25W Axial	51/1040/0047
R73	Resistor 10M 5% 0.25W Axial	51/1040/010M
R74	Resistor 4K7 5% 0.25W Axial	51/1040/04K7
R75	Resistor 4K7 5% 0.25W Axial	51/1040/04K7
R76	Resistor 10K 5% 0.25W Axial	51/1040/010K
R77	Resistor 1K0 5% 0.25W Axial	51/1040/01K0
R78	Resistor 6K49 1% 0.25W Axial	51/1010/6K49
R79	Resistor 28K7 1% 0.25W Axial	51/1010/28K7
R80	Resistor 5K11 1% 0.25W Axial	51/1010/5K11
R81	Resistor 5K11 1% 0.25W Axial	51/1010/5K11
R82	Resistor 5K11 1% 0.25W Axial	51/1010/5K11
R83	Resistor 5K11 1% 0.25W Axial	51/1010/5K11
R84	Resistor 100K 5% 0.25W Axial	51/1040/100K
R85	Resistor 2K2 5% 0.25W Axial	51/1040/02K2
R86	Resistor 680 5% 0.25W Axial	51/1040/0680

<u>Ref.</u>	<u>Description</u>	<u>Part Number</u>
R87	Resistor 2K2 5% 0.25W SM1206	51/3380/02K2
R88	Resistor 1K0 5% 0.25W Axial	51/1040/01K0
R89	Resistor 10K 5% 0.25W Axial	51/1040/010K
R90	Resistor 180 5% 0.25W Axial	51/1040/0180
R91	Resistor 100 5% 0.25W SM1206	51/3380/0100
R92	Resistor 180 5% 0.25W SM1206	51/3380/0180
R93	Resistor 270R 5% 0.25W SM1206	51/3380/0270
R94	Resistor 1K8 5% 0.25W Axial	51/1040/01K8
R95	Resistor 1K0 5% 0.25W Axial	51/1040/01K0
R96	Resistor 15R 5% 0.25W SM1206	51/3380/0015
R97	Resistor 470R 5% 0.25W SM1206	51/3380/0470
R98	Resistor 47R 5% 0.25W SM1206	51/3380/0047
R99	Resistor 10K 5% 0.25W SM1206	51/3380/010K
R100	Resistor 47R 5% 0.25W SM1206	51/3380/0047
R101	Resistor 4K32 1% 0.25W Axial	51/1010/4K32
R102	Resistor 4K32 1% 0.25W Axial	51/1010/4K32
R103	Resistor 4K32 1% 0.25W Axial	51/1010/4K32
R104	Resistor 470K 5% 0.25W Axial	51/1040/470K
R105	Resistor 1K0 5% 0.25W Axial	51/1040/01K0
R106	Resistor 560 5% 0.25W Axial	51/1040/0560
R107	Resistor 3K3 5% 0.25W Axial	51/1040/03K3
R108	Resistor 560 5% 0.25W Axial	51/1040/0560
R109	Resistor 1K0 5% 0.25W Axial	51/1040/01K0
R110	Resistor 100 5% 0.25W Axial	51/1040/0100
R111	Resistor 2K2 5% 0.25W Axial	51/1040/02K2
R112	Resistor 220K 5% 0.25W Axial	51/1040/220K
R113	Resistor 68 5% 0.25W Axial	51/1040/0068
R114	Resistor 47K 5% 0.25W Axial	51/1040/047K
R115	Resistor 1K0 5% 0.25W Axial	51/1040/01K0
R116	Resistor 10K 5% 0.25W Axial	51/1040/010K
R117	Resistor 1K0 5% 0.25W Axial	51/1040/01K0
R119	Resistor 22 5% 0.25W Axial	51/1040/0022
R120	Resistor 220 5% 0.25W Axial	51/1040/0220
R121	Resistor 120K 5% 0.25W Axial	51/1040/120K
R123	Resistor 150K 5% 0.25W Axial	51/1040/150K
R124	Resistor 150K 5% 0.25W Axial	51/1040/150K
R125	Resistor 680K 5% 0.25W Axial	51/1040/680K
R126	Resistor 680K 5% 0.25W Axial	51/1040/680K
R127	Resistor 470K 5% 0.25W Axial	51/1040/470K
R128	Resistor 560K 5% 0.25W Axial	51/1040/560K
R129	Resistor 470K 5% 0.25W Axial	51/1040/470K
R130	Resistor 470 5% 0.25W SM1206	51/3380/0470
R131	Resistor 47R 5% 0.25W SM1206	51/3380/0047
R132	Resistor 47R 5% 0.25W SM1206	51/3380/0047
R133	Resistor 510K 5% 0.25W Axial	51/1040/510K
R134	Resistor 270 5% 0.25W Axial	51/1040/0270
R135	Resistor 470 5% 0.25W Axial	51/1040/0470
R136	Resistor 1K0 5% 0.25W Axial	51/1040/01K0
R137	Resistor 10K 5% 0.25W Axial	51/1040/010K
R138	Resistor 22K 5% 0.25W Axial	51/1040/022K
R139	Resistor 4K7 5% 0.25W Axial	51/1040/04K7
R140	Resistor 100K 5% 0.25W Axial	51/1040/100K
R141	Resistor 10R 5% 0.25W Axial	51/1040/0010
R142	Resistor 470K 5% 0.25W SM1206	51/3380/470K
RN1	Resistor Pack 100K X8 DIP16	52/2002/100K
RN2	Resistor Pack 10K SIP10	52/2002/010K
RV1	Trimpot 10K 1 Turn Vertical	53/1020/010K
RV2	Trimpot 10K 1 Turn Vertical	53/1020/010K
RV3	Trimpot 10K 1 Turn Vertical	53/1020/010K
RV4	Trimpot 10K Multi-turn Horizontal	53/2060/010K

Ref.	Description	Part Number
S1	Switch PSH BTN SPDT & Capacitor	31/0005/E121
T1	Transformer Line 600 Ohm	37/2040/5065
U1	IC RS232 Inter MAX232C	26/2001/232C
U2	IC 3 State BUF 74HC244N	26/2030/244N
U3	IC Micro Super MC34064P-5	26/2000/064P
U4	IC 8 Bit Latch 74HC573N	26/2030/C573
U5	IC EPROM 27C256	26/2090/C256
U6	IC Frequency SYN MB1501 SO16X	26/2000/1501
U7	IC Quad OP Amplifier TLC274	25/2050/274C
U8	IC Dual FET OP Amplifier DIP8	25/1050/272C
U9	IC Quad OP Amplifier TLC274	25/2050/274C
U10	IC Analogue Gate MC14066B	26/2040/4066
U11	IC Quad NAND 74C00 DIP14	26/2031/4C00
U13	IC Micro 68HC11A1P	26/2000/HC11
U14	IC Volt Regulator LM7805	25/2040/7805
XO1	TCXO 12.8 MHz O91/143-2	32/2030/12.8
Y1	Crystal 8.0 MHz	32/2049/08M0
Y2	Crystal 4.0 MHz	32/2049/04M0

Coaxial Resonator (CR1) Listing for T350 – T500

Model	Part #
T350A	12/0001/T350
T350B	12/0001/T350
T350C	12/0001/T330
T500A	12/0001/T400
T500B	12/0001/T450

Power Amplifier Assembly (for PCB 30/9149)

These parts common to all Amplifiers on T350 / T500

Ref.	Description	Part Number
C1	Capacitor 1N0 5% 63V NPO SM1206	46/3300/01N0
C2	Capacitor 56P 5% 63V NPO SM1206	46/3300/056P
C4	Capacitor 27P 2% 100V NPO Rad.1	45/2680/027P
C5	Capacitor 10N 10% 50V X7R Rad.2	46/2001/010N
C6	Capacitor 27P 2% 100V NPO Rad.1	45/2680/027P
C7	Capacitor 1N0 5% 100V NPO Rad.2	46/2000/01N0
C12	Capacitor 10U 35V Rad Electro	41/2001/010U
C13	Capacitor 10U 35V Rad Electro	41/2001/010U
C14	Capacitor 22N 5% 63V MKT Rad.2	47/2010/022N
C15	Capacitor 1N0 5% 100V NPO Rad.2	46/2000/01N0
C16	Capacitor 100P 5% 63V NPO 1206	46/3300/100P
C17	Capacitor 100P 5% 63V NPO 1206	46/3300/100P
C18	Capacitor 1N0 5% 63V NPO SM1206	46/3300/01N0
C20	Capacitor 10U 35V Rad Electro	41/2001/010U
C21	Capacitor 27P 2% 100V NPO Rad.1	45/2680/027P
C23	Capacitor 1N0 5% 100V NPO Rad.2	46/2000/01N0
C24	Capacitor 27P 2% 100V NPO Rad.1	45/2680/027P
C25	Capacitor 10P 5% 63V NPO SM1206	46/3300/010P
C26	Capacitor 10P 5% 63V NPO SM1206	46/3300/010P

<u>Ref.</u>	<u>Description</u>	<u>Part Number</u>
C27	Capacitor 100N 10% 63V X7R 1206	46/3310/100N
C28	Capacitor 100N 10% 63V X7R 1206	46/3310/100N
C29	Capacitor 10U 35V Rad Electro	41/2001/010U
C30	Capacitor 1N0 5% 63V NPO SM1206	46/3300/01N0
C31	Capacitor 100N 10% 50V X7R Rad.2	46/2001/100N
C32	Capacitor 100N 10% 63V X7R 1206	46/3310/100N
C33	Capacitor 10U 35V Rad Electro	41/2001/010U
C34	Capacitor 1N0 5% 100V NPO Rad.2	46/2000/01N0
C35	Capacitor 22N 5% 63V MKT Rad.2	47/2010/022N
C36	Capacitor 27P 2% 100V NPO Rad.1	45/2680/027P
D1	Diode Schottkey BAT17 SOT23	21/3030/0017
D2	Diode Schottkey BAT17 SOT23	21/3030/0017
D3	Diode Silicon 1N4148	21/1010/4148
D4	Diode Silicon 1N4148	21/1010/4148
D5	Diode Silicon 1N4148	21/1010/4148
J2	Connector Coax SMB PCB Horizontal	35/2001/0001
L5	Inductor 1U0 10% Choke SM1008	37/3320/01U0
L6	Inductor 6 Hole Ferrite RFC	37/1021/0001
L7	Inductor 6 Hole Ferrite RFC	37/1021/0001
L8	Inductor 6 Hole Ferrite RFC	37/1021/0001
P1	Connector 16 Way Horizontal Shr'd Header	35/2503/0016
Q2	Transistor RF NPN MRF5812 SO8	27/3020/5812
Q3	Transistor GP PNP MPSW5 11A,A TO92	27/2010/PW51
Q4	Transistor GP NPN 2N3904 TO92	27/2020/3904
Q5	Transistor ZTX751 ZETEX TO92	27/2010/X751
Q6	Transistor GP NPN 2N3904 TO92	27/2020/3904
Q7	Transistor GP NPN 2N3904 TO92	27/2020/3904
R1	Resistor 220 5% 0.25W SM1206	51/3380/0220
R2	Resistor 100K 5% 0.25W Axial	51/1040/100K
R3	Resistor 100K 5% 0.25W Axial	51/1040/100K
R4	Resistor 100R 5% 0.25W Axial	51/1040/0100
R5	Resistor 220 5% 0.25W SM1206	51/3380/0220
R6	Resistor 15K 5% 0.25W Axial	51/1040/015K
R7	Resistor 100K 5% 0.25W Axial	51/1040/100K
R10	Resistor 4R7 5% 0.25W Axial	51/1040/04R7
R11	Resistor 1K 5% 0.25W Axial	51/1040/01K0
R12	Resistor 22 5% 0.25W Axial	51/1040/0022
R13	Resistor 470 5% 0.25W Axial	51/1040/0470
R14	Resistor 10K 5% 0.25W Axial	51/1040/010K
R15	Resistor 470 5% 0.25W Axial	51/1040/0470
R16	Resistor 470 5% 0.25W SM1206	51/3380/0470
R17	Resistor 5K6 5% 0.25W Axial	51/1040/05K6
R18	Resistor 1K0 5% 0.25W Axial	51/1040/01K0
R19	Resistor 100K 5% 0.25W Axial	51/1040/100K
R20	Resistor 100 5% 0.25W Axial	51/1040/0100
R21	Resistor 47K 5% 0.25W Axial	51/1040/047K
R22	Resistor 1K0 5% 0.25W Axial	51/1040/01K0
R23	Resistor 47K 5% 0.25W SM1206	51/3380/047K
R24	Resistor 47K 5% 0.25W SM1206	51/3380/047K
R25	Resistor 220R 5% 0.25W SM1206	51/3380/0220
R26	Resistor 220R 5% 0.25W SM1206	51/3380/0220
R27	Resistor 100K 5% 0.25W Axial	51/1040/100K
R28	Resistor 1M0 5% 0.25W Axial	51/1040/01M0
R29	Resistor 4K7 5% 0.25W Axial	51/1040/04K7
R30	Resistor 10K 5% 0.25W Axial	51/1040/010K
R31	Resistor 680R 5% 0.25W Axial	51/1040/0680
R32	Resistor 10K 5% 0.25W Axial	51/1040/010K
R33	Resistor 10K 5% 0.25W Axial	51/1040/010K
R34	Resistor 4K7 5% 0.25W Axial	51/1040/04K7
R35	Resistor 1M0 5% 0.25W Axial	51/1040/01M0

<u>Ref.</u>	<u>Description</u>	<u>Part Number</u>
R36	Resistor 47K 5% 0.25W Axial	51/1040/047K
R37	Resistor 15K 5% 0.25W Axial	51/1040/015K
R38	Resistor 4R7 5% 0.25W Axial	51/1040/04R7
R39	Capacitor 2P2 5% 63V NPO 1206	46/3300/02P2
RV1	Trimpot 10K 1 Turn Vertical	53/1020/010K
RV2	Trimpot 10K 1 Turn Vertical	53/1020/010K
U1	IC Quad OP Amplifier MC3403P	25/1050/3403

Additional parts for Amplifiers in all T350's

<u>Ref.</u>	<u>Description</u>	<u>Part Number</u>
L1	Inductor Moulded 3.5 Turn	37/2021/0003
L2	Inductor Moulded 3.5 Turn	37/2021/0003
L3	Inductor Moulded 3.5 Turn	37/2021/0003
L4	Inductor Moulded 3.5 Turn	37/2021/0003
C3	Capacitor 10P 5% 63V NPO SM1206	46/3300/010P
C8	Capacitor 4P5 5% 250V Silver Mica	48/3003/04P5
C9	Capacitor 13P 5% 250V Silver Mica	48/3003/013P
C10*	Capacitor 13P 5% 250V MC Mica	48/3002/013P
C11	Capacitor 4P5 5% 250V Silver Mica	48/3003/04P5
C37	Capacitor 22P 5% 63V NPO SM1206	46/3300/022P

*C10 is omitted from T350D

Additional parts for Amplifiers in all T500's

<u>Ref.</u>	<u>Description</u>	<u>Part Number</u>
L1	Inductor Moulded 2.5 Turn	37/2021/0002
L2	Inductor Moulded 2.5 Turn	37/2021/0002
L3	Inductor Moulded 2.5 Turn	37/2021/0002
L4	Inductor Moulded 1.5 Turn	37/2021/0001
C3	Capacitor 4P7 5% 63V NPO SM1206	46/3300/04P7
C8	Capacitor 3P 5% 250V Silver Mica	48/3003/003P
C9	Capacitor 10P 5% 250V Silver Mica	48/3003/010P
C10	Capacitor 10P 5% 250V MC Mica	48/3002/010P
C11	Capacitor 3P 5% 250V Silver Mica	48/3003/003P
C37	Capacitor 6P8 5% 63V NPO SM1206	46/3300/06P8

RF Power Module Listing for all Amplifiers

<u>Model</u>	<u>Frequency</u>	<u>RF Power Module</u>
T350A	360 – 380 MHz	18/M577/29SL
T350B	375 – 400 MHz	18/M577/29UL
T350C	330 – 365 MHz	18/M577/29EL
T350D	300 – 330 MHz	18/M577/29GL
T500A	400 – 430 MHz	18/M577/088L
T500B	430 – 500 MHz	18/M577/88UH
T500B	465 – 510 MHz	18/M577/88SH