

RIELLO 40 SERIES

MODELS 40 F3 & F5

EQUIPPED WITH ELECTRONIC AIR SHUTTER

INSTALLATION & OPERATING MANUAL

**RESIDENTIAL
OIL BURNERS**

NOTE: The settings in this manual are for retrofit applications. If this burner is being installed on a packaged unit (burner comes with the boiler or furnace), then follow the settings on the OEM page, as settings may differ. Burner is set for a single line system.

TABLE OF CONTENTS

TECHNICAL DATA - Model F3	3
TECHNICAL DATA – Model F5	4
OIL BURNER COMPONENT IDENTIFICATION	5
Serial Number Identification.....	5
INITIAL SET-UP	5
ASSEMBLY OF AIR TUBE TO BURNER CHASSIS.....	6
MOUNTING BURNER TO BOILER OR FURNACE.....	6
Method 1-Universal Mounting Flange.....	7
Method 2-Semi-flange Collar	7
Method 3-Pedestal Mount	8
FACTORY WIRING	8
APPLICATION FIELD WIRING.....	9
NOZZLE PLACEMENT	10
INSERTION/REMOVAL OF DRAWER ASSEMBLY	10
ELECTRODE SETTING.....	11
TURBULATOR SETTING.....	11
PUMP CONNECTIONS AND PORT IDENTIFICATION.....	11
Single Line (Gravity Feed)	12
Two Line (Lift System).....	12
PUMP PURGE.....	13
Single Line (Gravity System)	13
Two Line (Lift System).....	14
SETTING THE AIR ADJUSTMENT PLATE.....	14
BURNER ADJUSTMENT TABLES	15
AMULET INSTALLATION INSTRUCTIONS.....	16
SEQUENCE OF OPERATION.....	17&18
EXPLODED PARTS VIEW	19
PARTS LIST.....	20
START UP FORM	21
INSTALLATION PRECAUTIONS.....	22

PACKAGE LIST

Your Riello 40 burner should include the following parts. Please check to make sure all parts are present before beginning the installation.

QTY. DESCRIPTION (parts bag)

- 2 - Mounting flange bolts (short)
- 2 - Semi-flange bolts (long)
- 4 - Nuts
- 2 - Chrome nuts
- 1 - Oil pump connector (supply)
- 1 - Oil pump connector (return)
- 1 - Female ¼" NPT adapter
- 1 - Male 3/8" NPT adapter
- 1 - 2.5 mm Allen key

* OEM burners shipped with combustion head mounted

QTY. DESCRIPTION (carton)

- 1 - Burner chassis with cover
- 1 - Universal Mounting Flange
- 2 - Semi-flanges
- 1 - Mounting gasket
- 1 - Installation Manual
- 1 - By-pass plug

* (Separate carton)

- 1 - Combustion Head

RIELLO 40 F3 TECHNICAL DATA

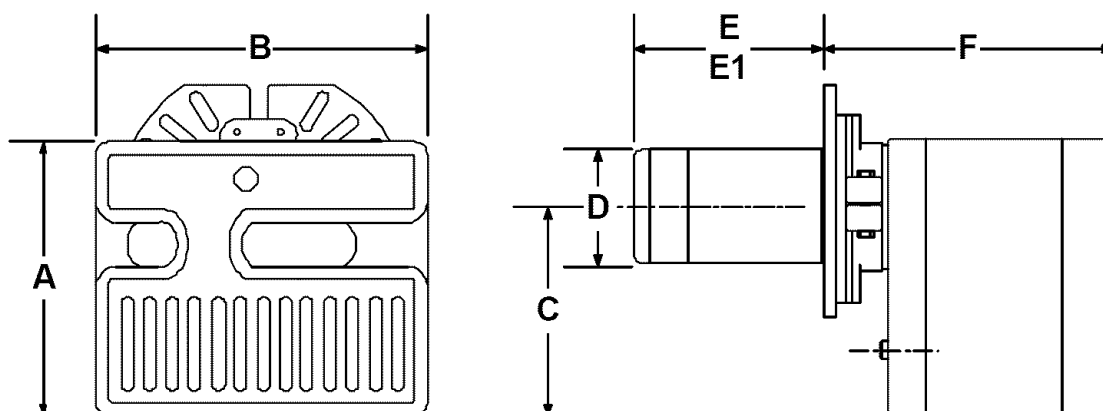

DIMENSIONS

MODEL F3	A	B	C	D	E	F
Inches	8 15/32	9 59/64	6 15/32	3 1/2	6	8 29/32
mm	215	252	164	89	152	226

E1: 10-inch long (254mm) tubes are also available.

SPECIFICATIONS

FUEL:	NO heavier than # 2 FUEL OIL
FIRING RATE:	0.50 to 0.95 US GPH
EFFECTIVE OUTPUT:	70,000 to 133,000 BTU/h
VOLTAGE (Single Phase):	120V 60Hz (+ 10% - 15%)
ABSORBED ELECTRICAL POWER:	155 Watts
MOTOR (rated):	3250 rpm Run Current 2.2 AMP
CAPACITOR:	12.5 Microfarads
PUMP PRESSURE:	130 to 200 psig
PRIMARY CONTROL:	RIELLO 530 SE/C
IGNITION TRANSFORMER:	8Kv 16mA

MOUNTING FLANGE DIMENSIONS

MODEL F3	A	B	C	D
Inch	1 1/4	1/4	7/16	2 3/16
mm	32	6	11	56

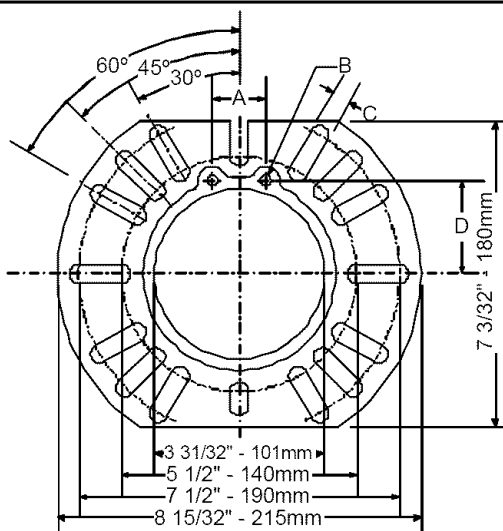

RIELLO 40 F5 TECHNICAL DATA

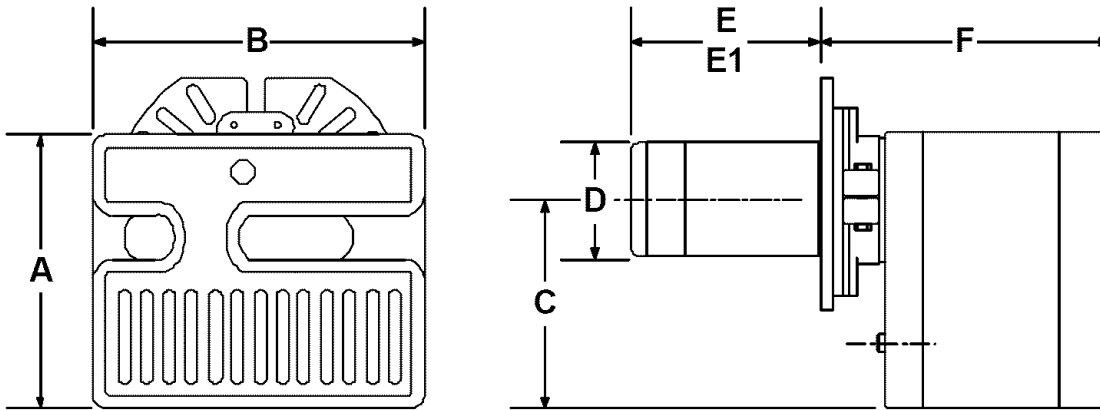

DIMENSIONS

MODEL F5	A	B	C	D	E	F
Inches	9 11/64	10 11/16	7 3/32	3 1/2	6	9 13/32
mm	233	272	180	89	152	239

E1: 10-inch long (254mm) tubes are also available.

SPECIFICATIONS

FUEL:	NO heavier than # 2 FUEL OIL
FIRING RATE:	0.75 to 1.65 US GPH
EFFECTIVE OUTPUT:	105,000 to 231,000 BTU/h
VOLTAGE (Single Phase):	120V 60Hz (+ 10% - 15%)
ABSORBED ELECTRICAL POWER:	175 Watts
MOTOR (rated):	3250 rpm - 2.2 AMP
CAPACITOR:	12.5 Microfarads
PUMP PRESSURE:	130 to 200 psig
PRIMARY CONTROL:	RIELLO 530 SE/C
IGNITION TRANSFORMER:	8Kv 16mA

MOUNTING FLANGE DIMENSIONS

MODEL F5	A	B	C	D
Inch	1 1/4	1/4	7/16	2 3/16
mm	32	6	11	56

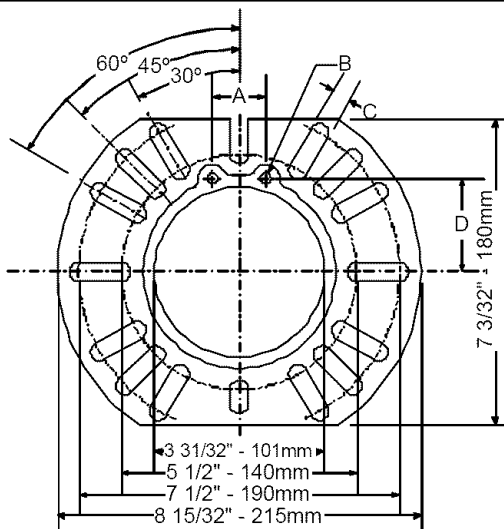

OIL BURNER COMPONENTS IDENTIFICATION

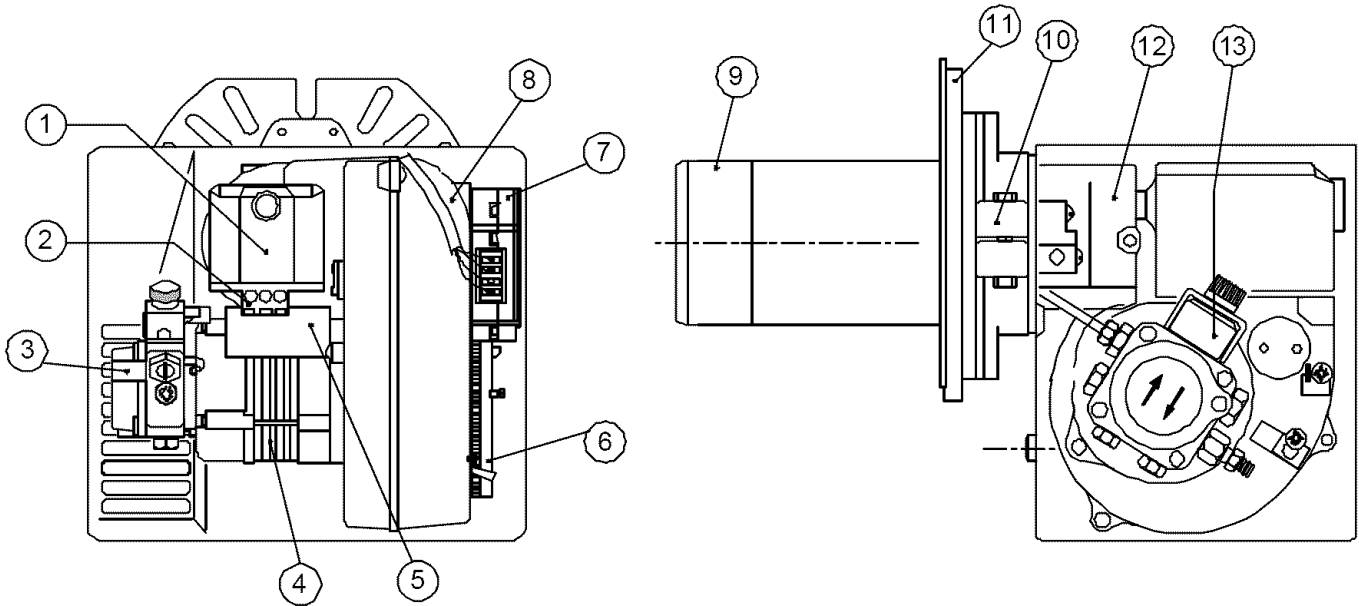

STANDARD RIELLO OIL BURNER MODELS 40 F3 & 40 F5 BURNER KEY COMPONENTS

- | | |
|---|---|
| <ol style="list-style-type: none"> 1. 530 SE/C INTEGRATED PRIMARY CONTROL 2. PRIMARY CONTROL SUB-BASE 3. FUEL UNIT (PUMP) 4. PSC MOTOR 5. CAPACITOR 6. AIR ADJUSTMENT AND SHUTTER | <ol style="list-style-type: none"> 7. ELECTRONIC AIR SHUTTER ASSY. 8. WIRE HARNESS FOR AIR SHUTTER 9. COMBUSTION HEAD WITH DRAWER ASSY. 10. SEMI FLANGE 2 PIECES 11. UNIVERSAL MOUNTING FLANGE & GASKET 12. AIR TUBE COVER PLATE 13. PUMP VALVE (COIL) |
|---|---|

***PLEASE READ THE MANUAL FOR SPECIFIC INFORMATION ON COMPONENTS**

****IF BURNER IS AN OEM BURNER KEY COMPONENTS MAY DIFFER SLIGHTLY**

BURNER SERIAL NUMBER IDENTIFICATION

The Riello 15 character serial number, example, **99 A 8511111 00025**, is identified as follows:

99 = last two digits of the year of manufacture; **A** = BI-week of manufacture; **8511111** = burner product code; **00025** = increment of 1 for each burner produced – specific to product code – reset to zero each January 1st.

(99) (A) 8511111 00025

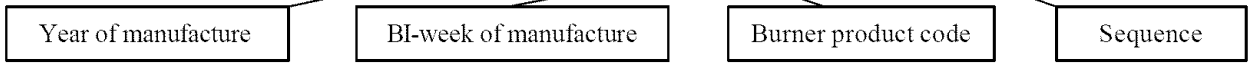

INITIAL SET-UP

- A) Remove burner and air tube from cartons. Check parts list (inside cover) to ensure all parts are present.
- B) Remove burner cover by loosening the three screws securing it. Remove control box and air tube cover (see page 8).
- C) Remove drawer assembly from air tube, insert nozzle and set Turbulator adjustment for specific input required (see pages 8 & 9), then set aside.
- D) Mount air tube to burner chassis. (see next page)

ASSEMBLY OF AIR TUBE TO BURNER CHASSIS

The air tube and drawer assembly are shipped in a carton separate from the burner chassis. Choose the proper air tube length to obtain the tube insertion for the specific installation.

- A) Remove the AIR TUBE and BURNER CHASSIS from their respective cartons.
- B) Remove the DRAWER ASSEMBLY (1) from inside the AIR TUBE by loosening the screw (2). Carefully pull the DRAWER ASSEMBLY out of the AIR TUBE, install the required nozzle (see page 8) and set aside.
- C) Remove the two BOLTS (3) from FRONT PLATE (4) of the BURNER CHASSIS. Align the two holes on the AIR TUBE HOLDING PATE (5) with the two holes on the BURNER CHASSIS FRONT PLATE with the BOLTS (3) removed. Replace the BOLTS and fingers tighten only. Re-install DRAWER ASSEMBLY into AIR TUBE. Tighten SCREW (2) securely (see page 8).
- D) Tighten the two bolts (3) securely.

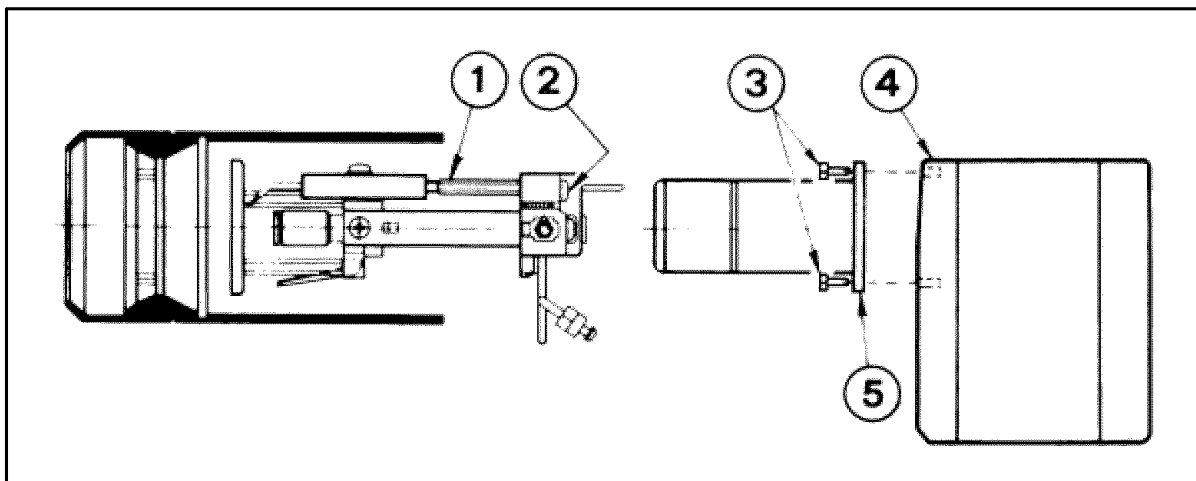

MOUNTING THE BURNER TO THE BOILER OR FURNACE

There are three possible methods to mount the burner, depending on the individual application. These are:

- 1) Universal flange bolted to Boiler/Furnace unit.
- 2) Semi-flange collar bolted to Boiler/Furnace unit.
- 3) Universal flange mounted to optional Pedestal mount, where flange mounting direct to appliance is not possible. Pedestal kit must be ordered separately.

METHOD 1 – UNIVERSAL MOUNTING FLANGE

- A) Insert the two BOLTS (1) into the UNIVERSAL MOUNTING FLANGE (10) from the flat side, ensuring the bolt heads are flush with the flat surface. Secure in place using two special CHROME NUTS (2) provided.

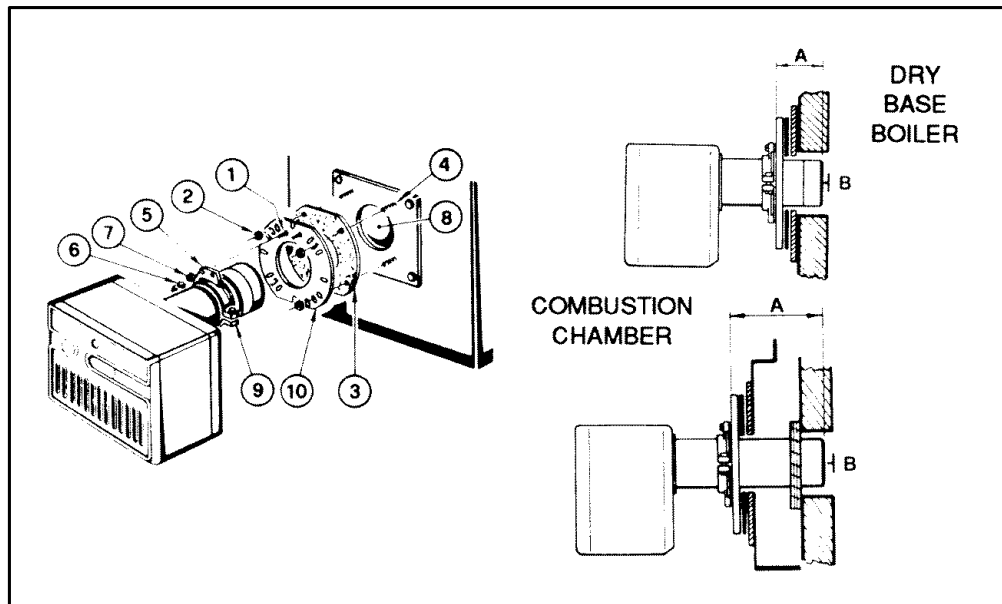

- B) Position the MOUNTING GASKET (3) between the flat surface of the UNIVERSAL MOUNTING FLANGE (10) and the appliance. Line up the holes in the UNIVERSAL MOUNTING FLANGE with the STUDS (4) on the appliance mounting plate and securely bolt the UNIVERSAL MOUNTING FLANGE to the plate.
- C) Secure the two semi-flanges of the ADJUSTABLE COLLAR (9) to the AIR TUBE using the two long BOLTS (6). Be sure that the ADJUSTABLE COLLAR (9) is properly positioned so the outside edge of the END CONE will be at least $\frac{1}{4}$ inch (6.5mm) back from the inside wall of the refractory of the combustion chamber (see dimension B above). The measured length (A) is to include MOUNTING GASKET and FLANGE, if used.
- D) The burner may now be attached to the heating unit by inserting the AIR TUBE through the BURNER ACCESS HOLE (8) and into the appliance, making sure the BOLTS (1) line up with the two HOLES (5) in the ADJUSTABLE COLLAR (9). Secure the burner in place using two NUTS (7).

A visual verification of the air tube insertion into the combustion chamber of the heating unit is suggested. Dimension B should be at least $\frac{1}{4}$ " (see drawing).

NOTE: A suggested method for creating mounting bolt holes in the mounting gasket: Hold the gasket against the appliance mounting bolts using the mounting flange for proper positioning. Lightly tap the flange with a hammer to form the holes.

METHOD 2 – SEMI-FLANGE COLLAR

- A) Follow item C from METHOD 1.
- B) Align the air tube and attached adjustable collar so air tube is centered in the burner access hole of the boiler/furnace unit. Mark the center of the two holes in the ADJUSTABLE COLLAR on to the front plate of the heating unit. Then drill $\frac{1}{4}$ inch (6.5mm) holes through the front plate of the unit, using marks as a guide.
- C) Install two short BOLTS (1) through the front plate of the heating unit from the inside, and secure on the outside using the two special CHROME NUTS (2).
- D) Follow item D from METHOD 1.

METHOD 3 – PEDESTAL MOUNT

Secure the MOUNTING FLANGE to MOUNTING PEDESTAL using the hardware provided with the pedestal. Secure burner to MOUNTING FLANGE as in METHOD 1, item A, C and D.

NOTE: It is suggested that the pedestal be anchored in position on the floor by installing brackets over the pedestal tube and securing brackets to the floor.

WARNING: WHEN THE COMBUSTION CHAMBER IS LINED WITH A REFRACTORY MATERIAL, IT IS IMPERATIVE THAT THE END CONE NOT PROTRUDE INTO THE CHAMBER AREA, AS EXCESSIVE HEAT AT BURNER SHUT DOWN MAY DAMAGE THE END CONE.

INTERNAL FACTORY WIRING

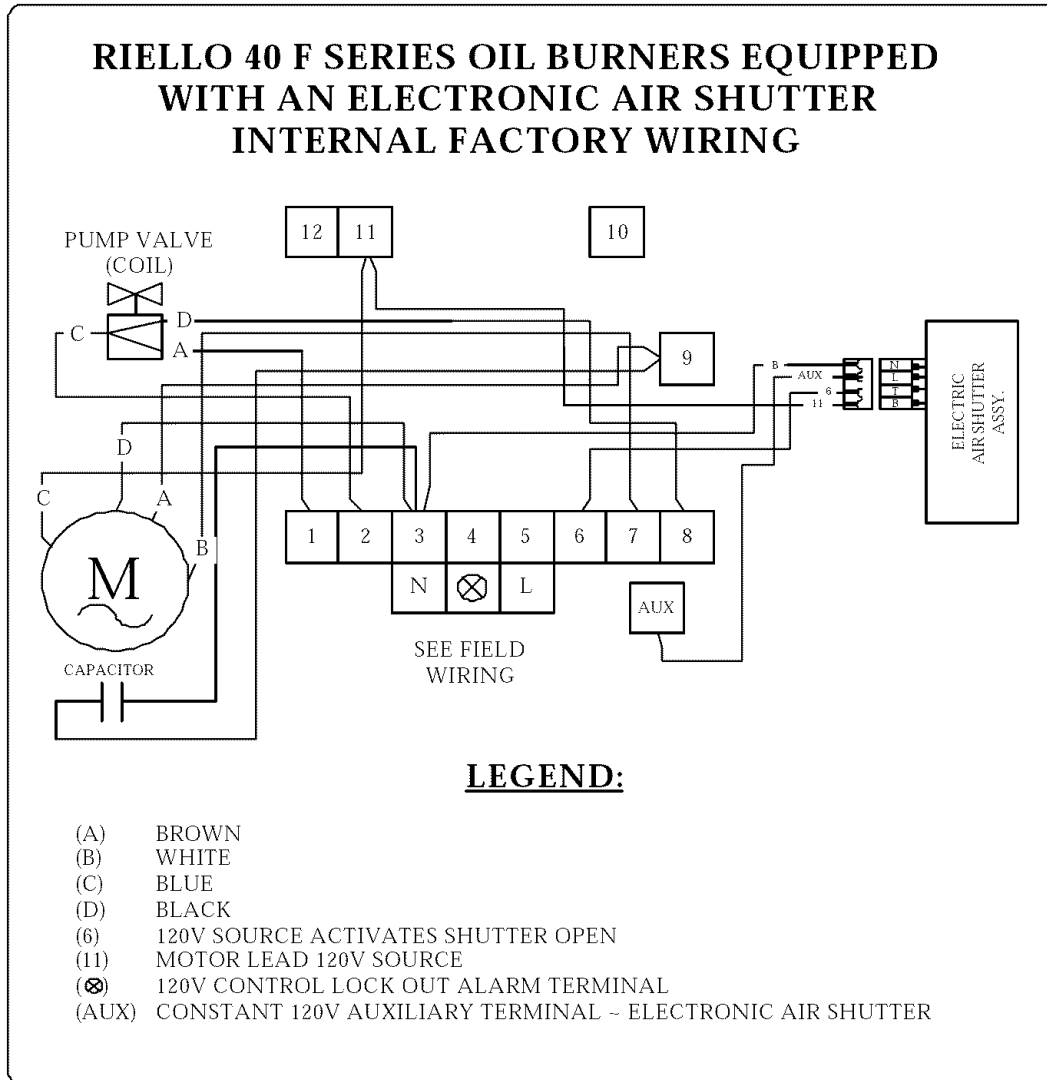

APPLICATION FIELD WIRING

WIRING DIAGRAM SHOWN BELOW FOR STANDARD RIELLO 530 SE/C PRIMARY CONTROL BOX

INSTALLATION NOTE: ELECTRONIC AIR SHUTTER REQUIRES A CONSTANT 120V POWER SUPPLY TO THE AUX TERMINAL, FAILURE TO PROVIDE THIS WILL RESULT IN NO BURNER OPERATION OR AIR SHUTTER WILL NOT CLOSE.

RECOMMENDED FIELD WIRING FOR TYPICAL APPLICATIONS

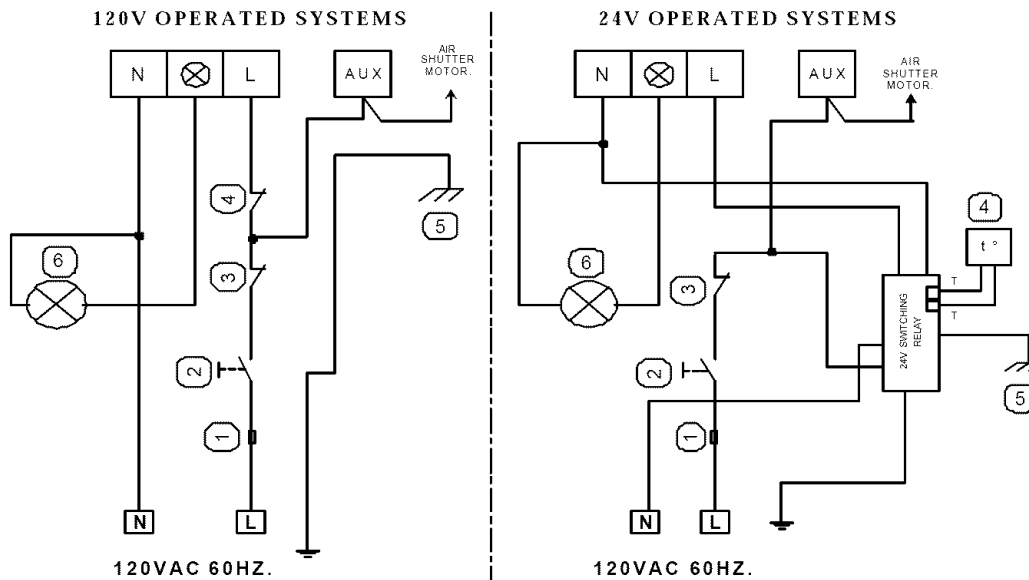

WIRING LEGEND:

PLEASE NOTE: OPERATING LIMIT AND SAFETY LIMIT ARE TWO SEPARATE LIMITS .

- (1) MAIN DISCONNECT FUSE
- (2) MANUAL SERVICE SWITCH
- (3) "SAFETY" LIMIT DEVICE
- (4) "OPERATING" LIMIT DEVICE
- (5) EARTH GROUND CONNECTION BURNER CHASSIS
- (6) BURNER CONTROL REMOTE LOCK OUT ALARM DEVICE - WIRED & SUPPLIED BY OTHERS.
- (AUX) AUXILIARY SUB BASE ADD-ON CONNECTOR (AIR SHUTTER)
- (T - T) 24V THERMOSTAT CONNECTIONS - LOW VOLTAGE OPERATED SYSTEMS

MIN. WIRE SIZE:
INSULATED 18 AWG SOLID OR 16 STRD.
RATED 105° C

PROPER EARTH GROUNDING MEANS REQ.'D

ALL WIRING SHOWN PROVIDED BY OTHERS

WARNING: DO NOT activate burner until proper oil line connections have been made, or failure of the pump shaft seal may occur.

WARNING: DO NOT activate burner until all safety and operating controls have been wired in series with the burner, as required by local code authorities and/or as specified by the appliance manufacturer.

NOZZLE PLACEMENT

- A) Determine the proper firing rate for the boiler or furnace units, considering the specific application, and then use the Burner Setup charts on page 15 to select the proper nozzle and pump pressure to obtain the required input from the burner.
- B) Remove the NOZZLE ADAPTER (2) from the DRAWER ASSEMBLY by loosening the SCREW (1).
- C) Insert the proper NOZZLE into the NOZZLE ADAPTER and tighten securely (Do not over tighten).
- D) Replace adapter, with nozzle installed, into drawer assembly and secure with screw (1).

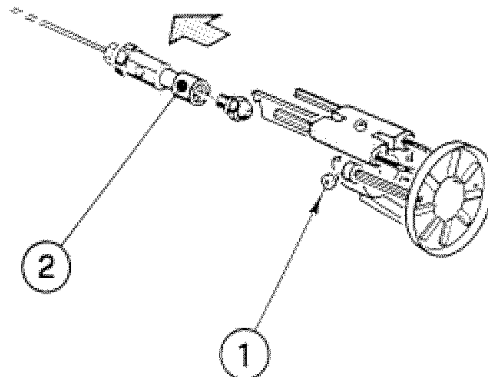

INSTALLATION/REMOVAL OF DRAWER ASSEMBLY

Removal:

- A) Loosen off oil delivery tube nut from pump.
- B) Loosen SCREW (3), and then unplug CONTROL BOX (1) by carefully pulling it back and then up.
- C) Remove the AIR TUBE COVER PLATE (5) by loosening the retaining SCREW (4) (Two SCREWS – Model F5).
- D) Loosen SCREW (2), and then slide the complete drawer assembly out of the combustion head as shown.
- E) To insert drawer assembly, reverse the procedure in items A to D above.

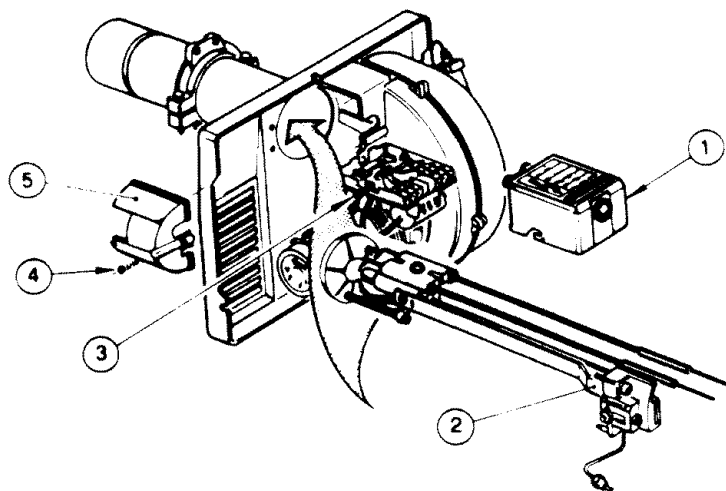

ELECTRODE SETTING

IMPORTANT: THIS DIMENSIONS MUST BE OBSERVED AND VERIFIED.

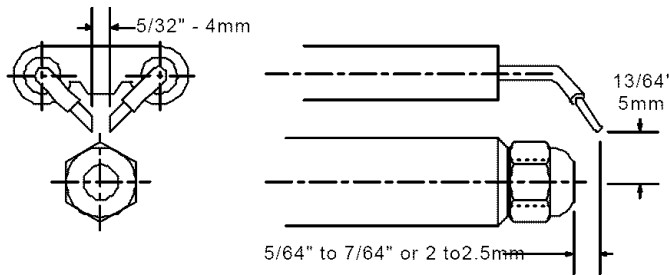

TURBULATOR SETTING

- A) Loosen NUT (1), and then turn SCREW (2) until the INDEX MARKER (3) is aligned with the correct index number as per the Burner Setup charts, or OEM specifications given with the appliance.
 B) Retighten the RETAINING NUT (1).

NOTE: OEM specifications take priority over retrofit specifications shown in this manual.

MODEL F3 NOTE: Zero and four are scale indicators only
 From left to right the first line is 4 and the last line 0.

MODEL F5: Same as above, except, scale indicators are 0 and 3.

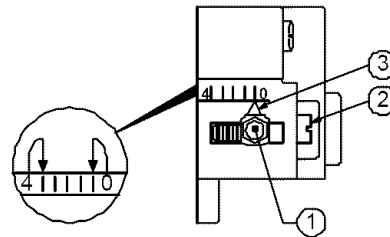

PUMP CONNECTIONS AND PORT IDENTIFICATION

This burner is shipped with the oil pump set to operate on a **single** line system. To operate on a **two-line** system the by-pass plug must be installed.

WARNING: Do not operate a **single** line system with the by-pass plug installed. Operating a **single** line system with the by-pass plug installed will result in damage to the pump shaft seal.

NOTE: Pump pressure must be set at time of burner start-up. A pressure gauge is attached to the **PRESSURE PORT (7)** for pressure readings. Two **PIPE CONNECTORS (4)** are supplied with the burner for connection to either a single or two-line system. Also supplied are two **ADAPTORS (3)**, two female 1/4" NPT, to adapt oil lines to burner pipe connectors. All pump port threads are **British Parallel Thread** design. Direct connection of NPT threads to the pump **will damage** the pump body.

Riello manometers and vacuum gauges **do not** require any adapters, and can be safely connected to the pump ports. An NPT (metric) adapter **must** be used when connecting other gauge models.

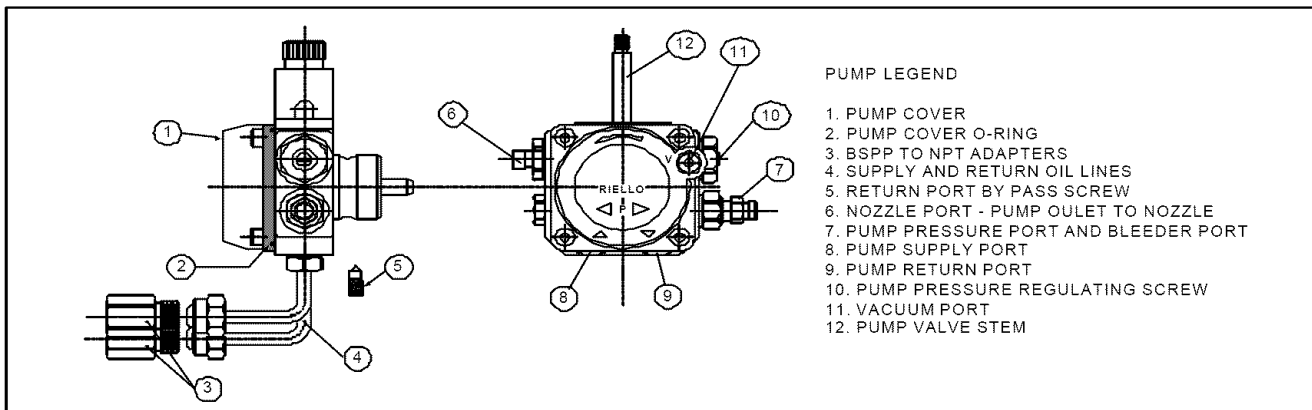

SINGLE LINE (GRAVITY FEED SYSTEM)

A) The burner is shipped configured for use in single line applications. No changes to the oil pump are required for use in single line applications.

NOTE: If the **pump cover** (1) is removed for any reason, be sure the O-ring (2), is properly seated in the pump cover (1) before re-attaching the pump cover to the pump housing.

SINGLE LINE SYSTEM-PIPE LENGTHS					
H		3/8" OD		1/2" OD	
FT	M	FT	M	FT	M
1.5	0.5	33	10	65	20
3.0	1.0	65	20	130	40
5.0	1.5	130	40	260	80
6.5	2.0	195	60	325	100

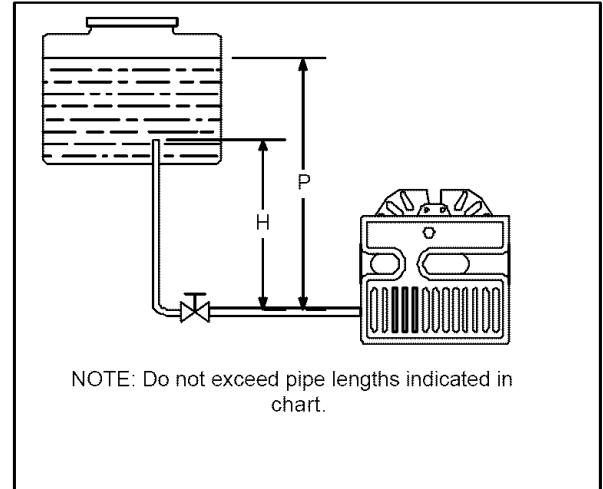

B) Connect the pipe connector to the SUPPLY PORT (5) of the pump. Attach the NPT adapter to the pipe connector. Attach the required piping to this pipe adapter. Be sure that the plug in the RETURN PORT (7) is tightened securely.

TWO LINE (LIFT SYSTEM)

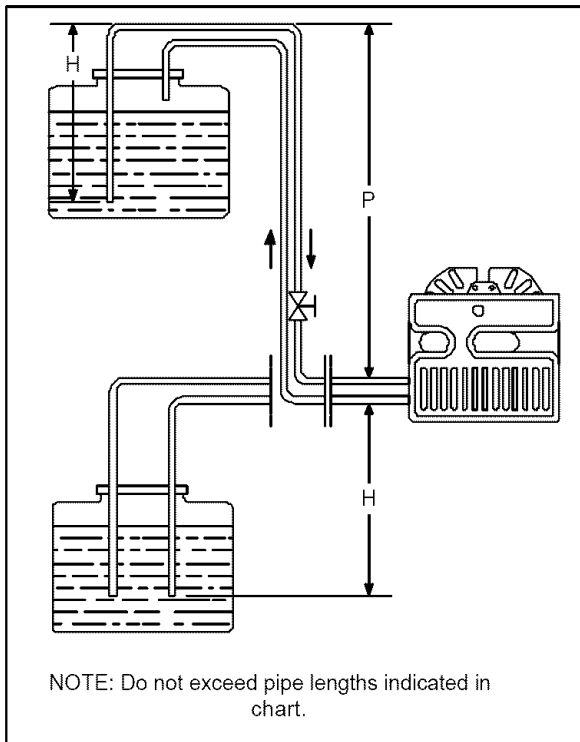

2 LINE (LIFT) SYSTEM-PIPE LENGTHS					
H		3/8" OD		1/2" OD	
FT	M	FT	M	FT	M
0.0	0.0	115	35	330	100
1.5	0.5	100	30	330	100
3.0	1.0	80	25	330	100
5.0	1.5	65	20	295	90
6.5	2.0	50	15	230	70
9.5	3.0	25	8	100	30
11	3.5	20	6	65	20

A) If a two-line system is required, install the By-pass plug provided. The by-pass plug is installed in the return port of the pump. A 2.5-mm hexagonal key provided with the by-pass plug is to be used to install the plug. **DO NOT** use an inch size hexagonal key; damage to the by-pass plug may result. When operating on a two-

line system, supply and return lines should be the same diameter and both **should extend to the same depth inside the fuel tank**. Be sure there are no air leaks or blockages in the piping system. Any obstructions in the return line will cause failure of the pump shaft seal. Do not exceed the pipe lengths indicated in the tables on page 10.

To install the by-pass plug:

- 1) Remove the return plug (7)
- 2) Install the by-pass plug (4) using the 2.5 mm hexagonal key

- B) Attach the two PIPE CONNECTORS (6) to the pump SUPPLY and pump RETURN PORTS (5 and 7). Attach the required piping to these two pipe connectors using the NPT/ METRIC ADAPTERS that are supplied with the burner.

WARNING: Pipe dope or Teflon tapes are NOT to be used on any direct oil connection to the fuel pump.

WARNING: The height 'P' in Pipe Length Charts should not exceed 13 feet (4 m).

WARNING: The vacuum should not exceed 11.44 inches of mercury.

IMPORTANT: An external, appropriately listed and certified oil filter must be placed in the fuel line between the fuel tank and the burner pump.

PUMP PURGE

NOTE: To protect the pump gears, it is advisable to lubricate the pump prior to purging a lift system. Apply oil through the VACUUM PORT (C).

A) SINGLE LINE (GRAVITY FEED SYSTEM)

- I. Loosen the bleeder valve (A) until oil flows out. Tighten the bleeder valve securely and start burner.
- II. When bleeding the pump by pressure:
 - 1) Loosen the bleeder valve (A).
 - 2) Disconnect nozzle oil supply line at the pump nozzle port (B).
 - 3) Attach a flexible plastic tube to the pump nozzle, port directing the oil flow into a bucket.
 - 4) Loosen the screw(s) securing the air tube cover, allowing it to be removed freely.
 - 5) Holding the air tube cover in its proper location start the burner.
 - 6) When the solenoid valve is engaged approximately 10 seconds after starting, remove the air tube cover and shine a light source on the photocell, allowing it to see false light.
 - 7) Run the burner until the fuel pump has been purged of air, then tighten the bleeder valve and immediately shut down the burner.
 - 8) Reinstall the air tube cover and nozzle line
 - 9) The burner can now be started normally.

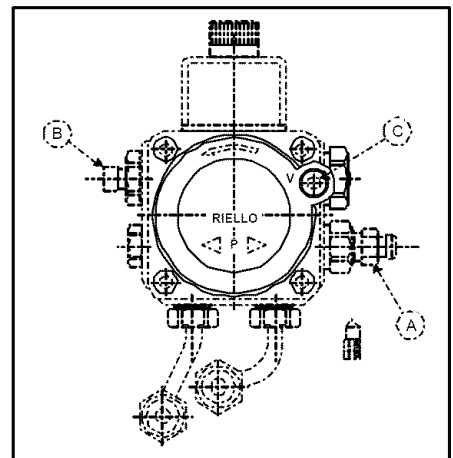

WARNING: Omitting steps 2 and 3 will result in a collection of unburned oil in the combustion chamber creating a hazardous situation upon burner startup.

B) TWO LINE (LIFT SYSTEM)

Turn off the main power source to the burner and remove the air tube cover. Shine a light source on the photocell (now visible where the air tube cover was removed), return power to the burner and activate the burner. With the light source in place, the burner will operate in prepurge only. When the pump is sufficiently purged, the hydraulic air shutter will open. Once the burner is purged, turn off the power source and replace the air tube cover. Return power to the burner. The burner is now ready to operate.

ATTENTION: It is important that the fuel line be completely sealed and free from air leaks or any internal blockages.

WARNING! WHEN THE BYPASS PLUG IS INSTALLED, A TWO-PIPE SYSTEM MUST BE USED OR FAILURE OF THE PUMP SHAFT WILL OCCUR.

SETTING THE AIR ADJUSTMENT PLATE

The electronic air shutter assembly (1) is operated on a 120v 60Hz. motor, and the burner motor will not operate until the air shutter is in its fully open position.

Set the air plate (4) setting according to OEM setup information or by following the Retrofit settings listed in this manual. To adjust the air plate (4) to the desired set point indicator (2), loosen the center air shutter assembly screw (5) and loosen the side air plate screw (3), move air plate (4) by using the air plate adjust arm. After adjustments are made please retighten screws (3) & (5).

The final position of the air adjustment plate will vary on each installation. Using proper combustion test instruments to establish the proper setting of the air gate setting to achieve safe and efficient results according to the appliance information or if not available.

NOTE: Variations in flue gas, smoke, CO₂ and temperature readings may be experienced when burner cover is put in place. Therefore, the burner cover **must** be in place when making final combustion instrument readings, to ensure proper test results are obtained.

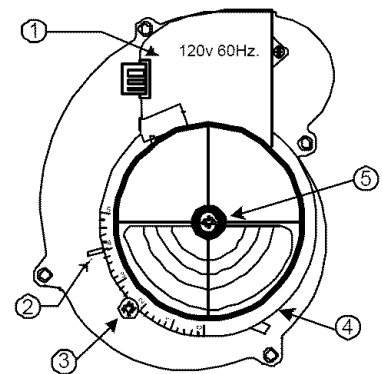

BURNER ADJUSTMENT TABLES

NON-RETROFIT APPLICATIONS

If this burner is being installed in a packaged unit (i.e. Burner comes with a boiler or furnace), follow the installation and set-up instructions supplied with the heating appliance, as settings will differ from those shown in this manual.

MODEL F3 BURNER SETUP CHART

ACTUAL FIRING RATE 5% ±	NOZZLE SIZE	PUMP PRESSURE		TURBULATOR SETTING	AIR DAMPER SETTING
		US GPH	GPH		
0.50	.40 x 60°/80°	160	11.0	0.0	2.3
0.60	.50 x 60°/80°	150	10.4	0.5	2.7
0.75	.60 x 60°/80°	150	10.4	1.5	3.4
0.80	.65 x 60°/80°	150	10.4	2.0	3.6
0.95	.75 x 60°/80°	160	11.0	3.0	4.3

MODEL F5 BURNER SETUP CHART

ACTUAL FIRING RATE 5% ±	NOZZLE SIZE	PUMP PRESSURE		TURBULATOR SETTING	AIR DAMPER SETTING
		US GPH	GPH		
0.75	.60 x 60/ 80°	145	10	0.0	2.25
0.85	.65 x 60/ 80°	145	10	0.5	2.5
1.00	.85 x 60/ 80°	145	10	1.0	2.75
1.10	1.00 X 60/ 80°	145	10	2.0	3.0
1.25	1.10 x 60/ 80°	145	10	2.5	3.5
1.50	1.25 x 60/ 80°	145	10	3.0	4.25
1.65	1.35 X 60/ 80°	145	10	4.0	6.0

NOTE: The above set up charts are a starting point only. The burner and appliance must be properly set up using proper combustion testing equipment.

Note: any approved oil burner nozzle type, angle and manufacturer may be used, as long as input is corresponding the correct BTU/hr. or US gph input rating of the appliance.

COMBUSTION CHAMBER

Follow the instructions furnished by the boiler/furnace manufacturer. Size retrofit application according to the appropriate installation codes (e.g. CSA B139 or NFPA #31).

AMULET INSTALLATION INSTRUCTIONS

(Required on some models)

The amulets provided have been selected by Riello to protect the combustion tube from hot exhaust gases and flame. This protection may be needed in applications where the combustion tube opening in the combustion chamber refractory is larger than the tube outside diameter.

The amulet has been sized to fit Riello Model 40 sizes F3 and F5 plus the Riello Model R35.

When installing this amulet, handle it carefully. Do not exert undue pressure when pushing the amulet over the combustion tube. Excessive force can result in a broken amulet!

If the amulet will not fit easily onto the tube, remove a small amount of the inner diameter with a sharp knife to provide the necessary clearance.

The diagram below shows the proper position of the amulet after installation.

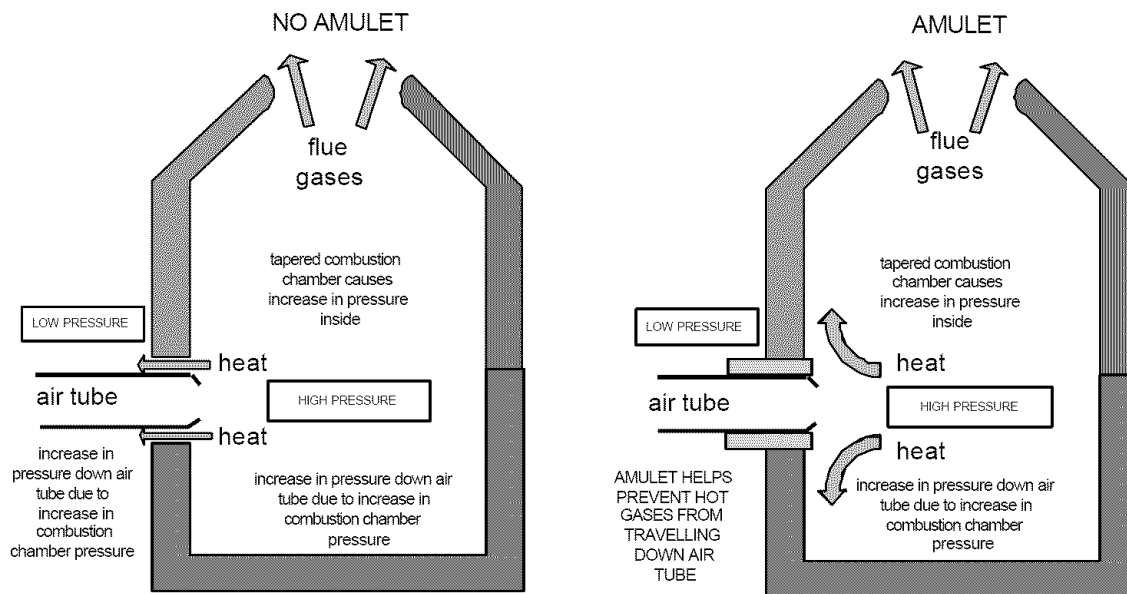
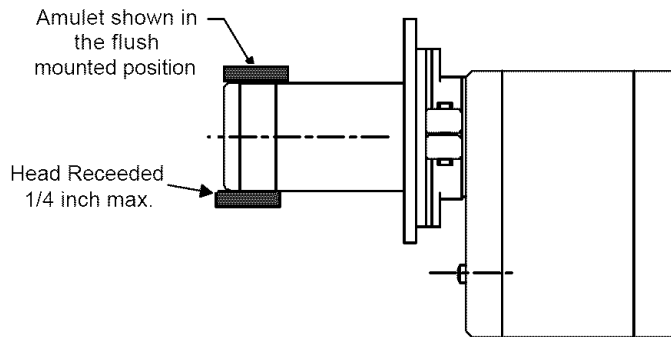



RIELLO 40 SERIES OIL BURNER EQUIPPED WITH ELECTRONIC AIR SHUTTER NORMAL OPERATIONAL SEQUENCE

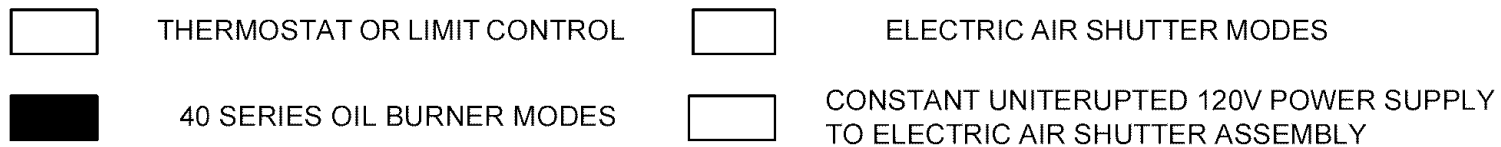
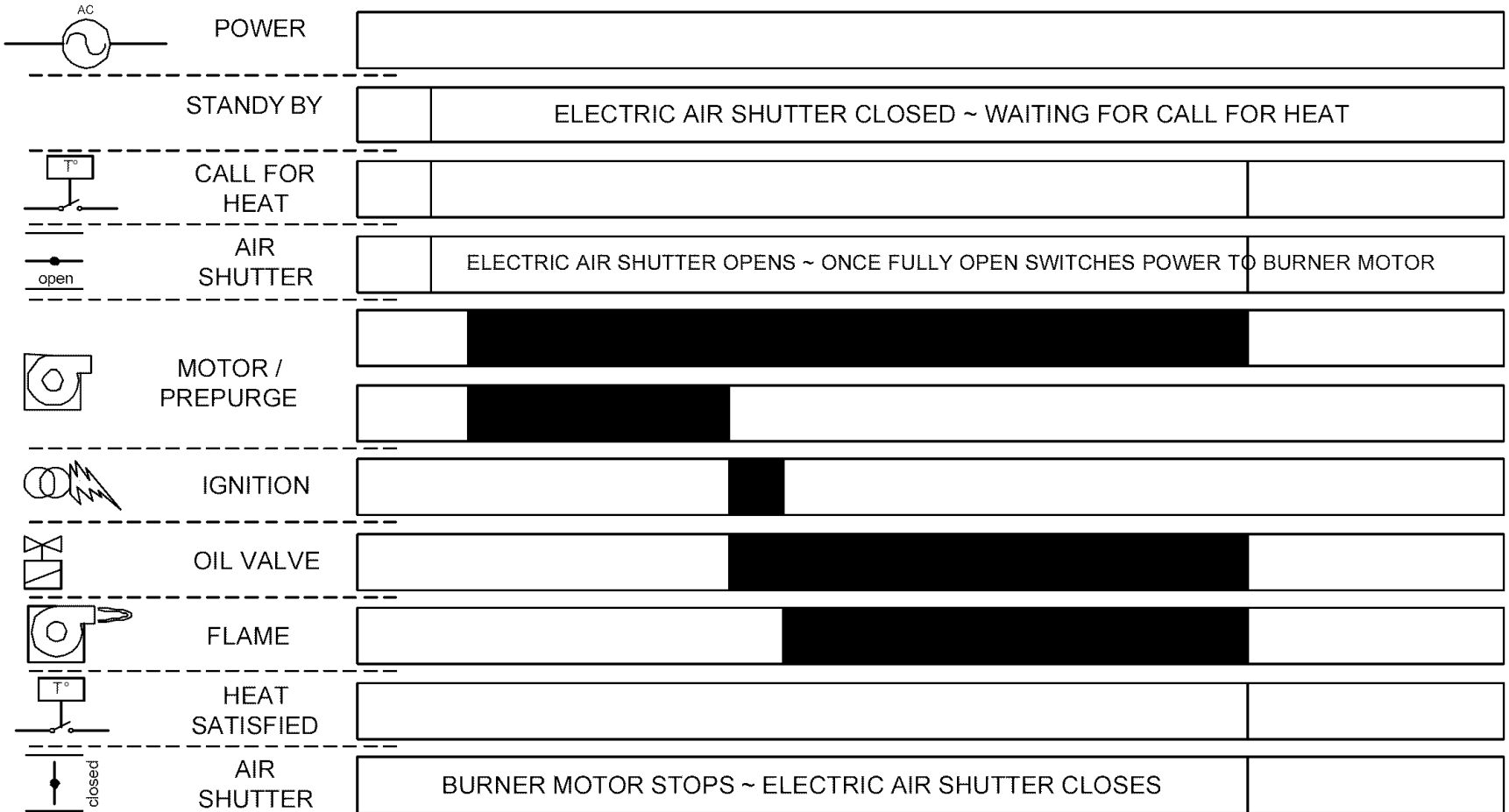



RIELLO 40 SERIES OIL BURNER EQUIPPED WITH ELECTRONIC AIR SHUTTER NO FLAME OPERATIONAL SEQUENCE

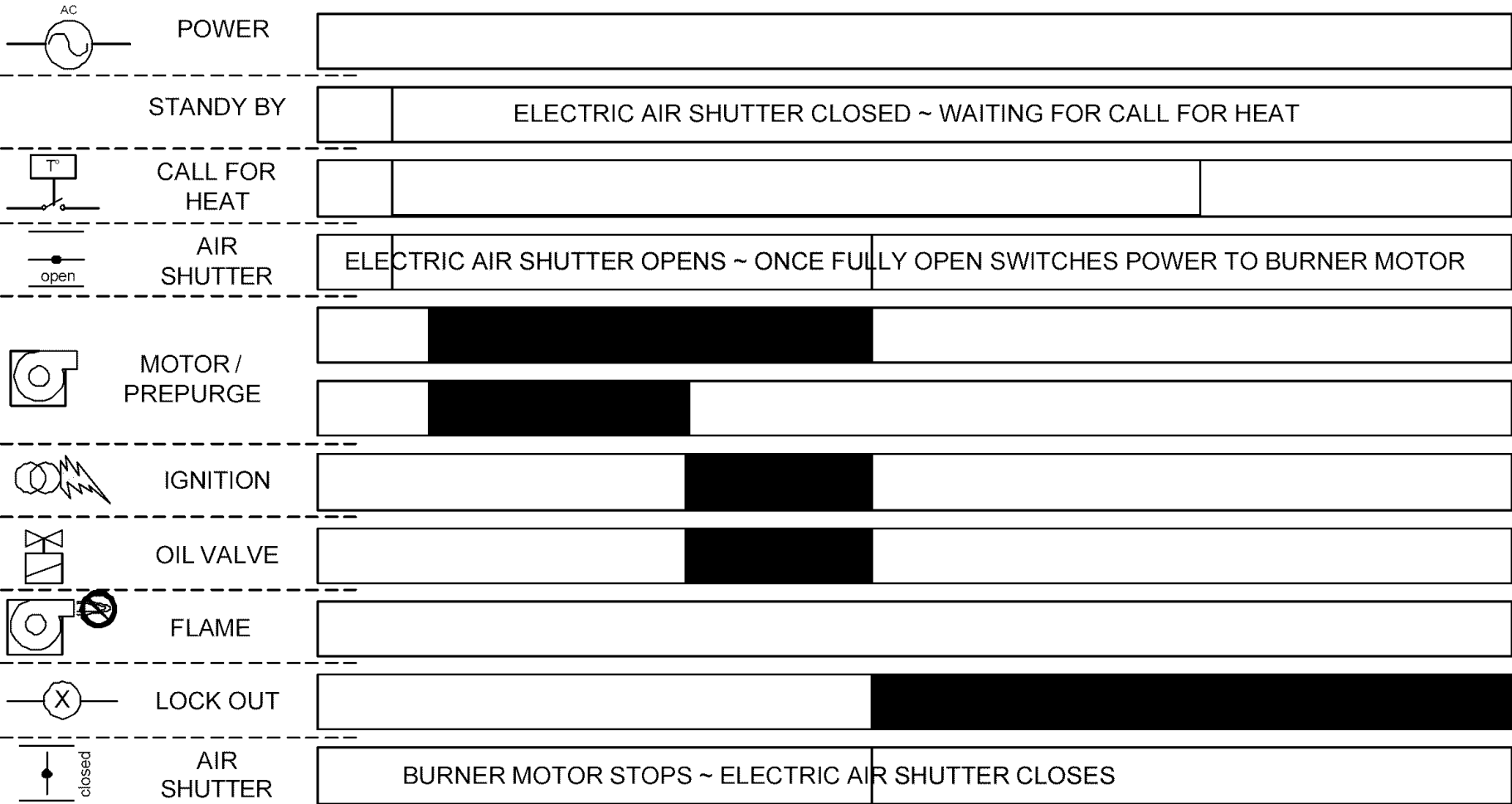

[]	THERMOSTAT OR LIMIT CONTROL	[]	ELECTRIC AIR SHUTTER MODES
[]	40 SERIES OIL BURNER MODES	[]	CONSTANT UNITERUPTED 120V POWER SUPPLY TO ELECTRIC AIR SHUTTER ASSEMBLY

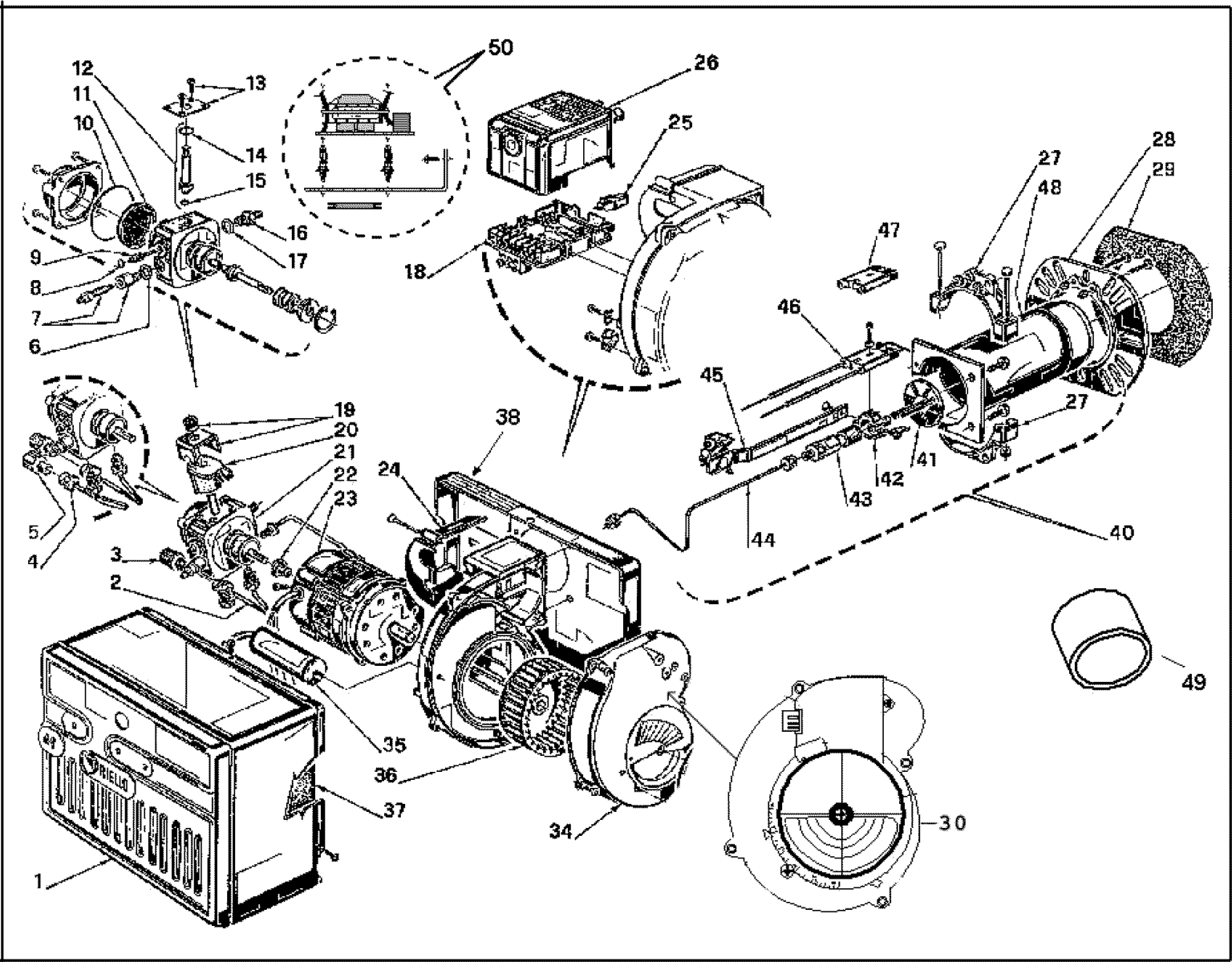

SPARE PARTS

RIELLO SPARE PARTS LIST revised November 6, 2002

• Indicates applicable model for each part.

No	CODE	F3	F5	DESCRIPTION	No	CODE	F3	F5	DESCRIPTION
1	3007232	•		Burner Back Cover	26	N/A	•	•	Primary Control
2	3007233	•	•	Burner Back Cover	27	3005854	•	•	Semi Flange (2 Required)
3	3006992	•	•	Pipe Connector Supply	28	3005855	•	•	Universal Mounting Flange
	3006571	•	•	3/8" NPT/Metric Adapter – Male	29	3005856	•	•	Mounting Gasket
4	3006993	•	•	Pipe Connector Return	30	C7001081	•		F3 replacement air damper kit
5	3005847	•	•	1/4" NPT/Metric Adapter – Female		C7001082		•	F5 replacement air damper kit
6	3007077	•	•	Crushable Metal Washer 3/8" ID					
7	3007568	•	•	Bleeder					
8	3007028	•	•	O-Ring – Pump Pressure Regulator					
9	3007202	•	•	Regulator Screw	34	3007207	•		Air Intake Housing
10	C7010002	•	•	O-Ring – Pump Cover (3007162)		3007208		•	Air Intake Housing
11	3005719	•	•	Pump Screen	35	3005844	•	•	Capacitor 12.5µF
12	3006925	•	•	Valve Stem	36	3005708	•	•	Fan
13	3007203	•	•	Valve Stem Plate	37	C6950050	•		Acoustic Liner
14	3007029	•	•	O-Ring - Valve Stem Upper		3007320		•	Acoustic Liner
15	3007156	•	•	O-Ring - Valve Stem Lower	38	3007221	•		Chassis Front Plate
16	3007268	•	•	Nozzle Outlet Fitting		3007222		•	Chassis Front Plate
17	3007087	•	•	Crushable Metal Washer 5/8" ID					
18	N/A	•	•	Primary Control Sub-Base	OPTIONAL				
19	3006553	•	•	Coil U-Bracket and Knurled Nut	49	C7001033	•	•	Amulet – Cerafelt Sleeve Kit
20	3002279	•	•	Coil					
21	3007802	•	•	Pump	50	C7001066	•	•	Type L 24 volt switching relay
22	3000443	•	•	Pump Drive Key					
23	3005843	•	•	Motor 120VOLT 60Hz					
24	3007315	•		Air Tube Cover					
	3007316	•	•	Air Tube Cover	51	2623141	•	•	Capillary port plug
25	3002280	•	•	Photocell	52	3000932	•	•	Adjustable Steel Flange

VSBT COMBUSTION HEAD					SHORT COMBUSTION HEAD				
40	3948876	•		VSBT Combustion Head 3"	40	3948873	•		Short Combustion Head 6" (271T1)
	3948976		•	VSBT Combustion Head 3"		3948973		•	Short Combustion Head 6" (271T1)
41	3006968	•		Turbulator Disc	41	3006968	•		Turbulator Disc
	3006977		•	Turbulator Disc		3006977		•	Turbulator Disc
42	3006966	•	•	Electrode Support	42	3006966	•	•	Electrode Support
43	3006965	•	•	Nozzle Adapter	43	3006965	•	•	Nozzle Adapter
44	3008627	•		Nozzle Oil Tube	44	3006969	•		Nozzle Oil Tube – Short
	3008629		•	Nozzle Oil Tube		3006973		•	Nozzle Oil Tube – Short
45	3008633	•		Regulator Assembly	45	3006324	•		Regulator Assembly – Short
	3008634		•	Regulator Assembly		3006323		•	Regulator Assembly – Short
46	3008630	•		Electrode Assembly	46	3006330	•		Electrode Assembly – Short
	3008631		•	Electrode Assembly		3006329		•	Electrode Assembly – Short
47	3005869	•	•	Electrode Porcelain	47	3005869	•	•	Electrode Porcelain
48	3008623	•		Air Tube only	48	3007592	•		Air Tube only
	3008626		•	Air Tube only		3007594		•	Air Tube only
8 7/8" COMBUSTION HEAD					LONG COMBUSTION HEAD				
40	3948877	•		Combustion Head 8 7/8"	40	3948874	•		Long Combustion Head 10" (271T2)
	3948975		•	Combustion Head 8 7/8"		3948974		•	Long Combustion Head 10" (271T2)
41	3006968	•		Turbulator Disc	41	3006968	•		Turbulator Disc
	3006977		•	Turbulator Disc		3006977		•	Turbulator Disc
42	3006966	•	•	Electrode Support	42	3006966	•	•	Electrode Support
43	3006965	•	•	Nozzle Adapter	43	3006965	•	•	Nozzle Adapter
44	3008970	•		Nozzle Oil Tube	44	3006970	•		Nozzle Oil Tube – Long
	3008628		•	Nozzle Oil Tube		3006974		•	Nozzle Oil Tube – Long
45	3008846	•		Regulator Assembly	45	3005867	•		Regulator Assembly – Long
	3008635		•	Regulator Assembly		3005878		•	Regulator Assembly – Long
46	3008789	•		Electrode Assembly	46	3005870	•		Electrode Assembly – Long
	3008632		•	Electrode Assembly		3005880		•	Electrode Assembly – Long
47	3005869	•	•	Electrode Porcelain	47	3005869	•	•	Electrode Porcelain
	3008788	•		Air Tube only		48	3007593	•	
48									
		3008625		•	Air Tube only		3007595		•

35 Pond Park Rd.
Hingham, MA 02043
Phone: 781-749-8292
Toll Free: 800-992-7637
Fax: 781-740-2069



2165 Meadowpine Blvd.
Mississauga, On L5H R2
Phone: 905-542-0303
Toll Free: 800-387-3898
Fax: 905-542-1525

BURNER START - UP FORM *

Burner S/N. or Model:	_____	Appliance:	_____
Installer name:	_____		
Company:	_____	Installation date:	_____
Address:	_____		
Phone:	_____	Fax:	_____
Owner Name:	_____		
Address:	_____		
Phone:	_____	E-mail:	_____

Burner Start-up Info (OIL)

Nozzle Info:	_____		
Pump Pressure:	_____		
Air Setting:	Turbulator setting:	_____	
Draft Over fire:	Draft breech:	_____	
CO ₂ :	CO:	O ₂ :	_____
Smoke density:	_____(Bacharach) _____		
Single Line:	<input type="checkbox"/>	Two Lines:	<input type="checkbox"/>

Burner Start-up Info (GAS)

Gas Supply Pressure:	_____		
Pump pressure:	_____		
Air Setting:	Head Setting:	_____	
Draft Over fire:	Draft breech:	_____	
CO ₂ :	CO:	O ₂ :	_____
Manifold pressure:	_____		
Ionization Reading (μAd.c.):	Input BTU/Hr:	_____	

This form was designed and provided in the installation manual for reference and also for providing technical information, which can be faxed or mailed to our technical hot-line coordinator when technical assistance is required. Please complete this form, fax it or mail it at the address/fax above, or send an e-mail with the information listed below to: techservices@riellocanada.com

INSTALLATION PRECAUTIONS

AIR FOR COMBUSTION

Do not install burner in room with insufficient air for combustion. Be sure there is an adequate air supply for combustion if the boiler/furnace room is enclosed. It may be necessary to create a window to permit sufficient air to enter the boiler/furnace room. The installer must follow local ordinances in this regard.

CANADA: It is suggested that the installer follow CSA standard B139.

USA: It is suggested that the installer follow NFPA manual #31.

CHIMNEY

Be sure chimney is sufficient to handle the exhaust gases. It is recommended that only the burner be connected to the chimney. Be sure that it is clean and clear of obstructions.

OIL FILTER

An external oil filter is **REQUIRED**, even though there is an internal strainer in the pump. The filter should be replaced at least once a year, and the filter container should be thoroughly cleaned prior to installing a new filter cartridge.

DRAFT

Follow the instructions furnished with the heating appliance.

The pressure in the combustion area should be kept as close to zero as possible. The burner will operate with a slight draft or pressure in the chamber.

ELECTRICAL CONNECTIONS

CANADA

All electrical connections should be done in accordance with the C.E.C. Part 1, and all local codes. The system should be grounded.

USA

All electrical connections should be done in accordance with the National Electrical Code, and all local ordinances. The system should be grounded.

CONTROL BURNER OPERATION

Check out the burner and explain its operation to the homeowner. Be sure to leave the Owner's Instruction sheet with the homeowner.

FIRE EXTINGUISHER

If required by local codes, install an approved fire extinguisher.

ELECTRICAL CONNECTIONS

In most localities, a number 14 wire should be used inside a metal conduit. The system should be grounded. A service switch should be placed close to the burner on a fireproof wall in an easily accessible location.

RIELLO

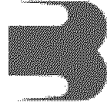

BURNERS

35 Pond Park Road
Hingham, MA 02043
Phone 781-749-8292
Toll Free 800-992-7637
Fax 781-740-2069

www.riellousa.com

2165 Meadowpine Blvd
Mississauga, ON L5N 6H6
Phone 905-542-0303
Toll Free 800-387-3898
Fax 905-542-1525

www.riellocanada.com

Technical Support Hotline

1-800-4-RIELLO

1-800-474-3556