

<Specifications (Precautions and Prohibitions)>

• Precaution on using ROHM Products

- 1) Our Products are designed and manufactured for application in ordinary electronic equipment (such as AV equipment, OA equipment, telecommunication equipment, home electronics appliances, amusement equipment, etc.). If you intend to use our Products in devices requiring extremely high reliability (such as medical equipment, transport equipment, traffic equipment, aircraft/spacecraft, nuclear power controllers, fuel controllers, car equipment including car accessories, safety devices, etc.) and whose malfunction or failure may cause loss of human life, bodily injury or serious damage to property (“Special Applications”), please consult with the ROHM sales representative in advance. Unless otherwise agreed in writing by ROHM in advance, ROHM shall not be in any way responsible or liable for any damages, expenses or losses incurred by you or third parties arising from the use of any ROHM’s Products for Specific Applications.

- 2) ROHM designs and manufactures its Products subject to strict quality control system. However, semiconductor products can fail or malfunction at a certain rate. Please be sure to implement, at your own responsibilities, adequate safety measures including but not limited to fail-safe design against the physical injury, damage to any property, which a failure or malfunction of our Products may cause. The following are examples of safety measures.
 - [a] Installation of protection circuits or other protective devices to improve system safety
 - [b] Installation of redundant circuits to reduce the impact of single or multiple circuit failure

- 3) Our Products are designed and manufactured for use under standard conditions and not under any special or extraordinary environments or conditions, as exemplified below. Accordingly, ROHM shall not be in any way responsible or liable for any damages, expenses or losses arising from the use of any ROHM’s Products under any special or extraordinary environments or conditions. If you intend to use our Products under any special or extraordinary environments or conditions (as exemplified below), your independent verification and confirmation of product performance, reliability, etc. prior to use, must be necessary:
 - [a] Use of our Products in any types of liquid, including water, oils, chemicals, and organic solvents
 - [b] Use of our Products outdoors or in places where the Products are exposed to direct sunlight or dust
 - [c] Use of our Products in places where the Products are exposed to sea winds or corrosive gases, including Cl₂, H₂S, NH₃, SO₂, and NO₂
 - [d] Use of our Products in places where the Products are exposed to static electricity or electromagnetic waves
 - [e] Use of our Products in proximity to heat-producing components, plastic cords, or other flammable items
 - [f] Sealing or coating our Products with resin or other coating materials
 - [g] Use of our Products without cleaning residue of flux (even if you use no-clean type fluxes, cleaning residue of flux is recommended); or Washing our Products by using water or water-soluble cleaning agents for cleaning residue after soldering
 - [h] Use of the Products in places subject to dew condensation

- 4) The products might receive the radio wave interference from electronic devices such as Wireless LAN devices, Bluetooth devices, digital cordless telephone, microwave oven and so on that radiate electromagnetic wave.

- 5) The Products are not subject to radiation-proof design.

- 6) Please verify and confirm characteristics of the final or mounted products in using the Products.

DESIGN	CHECK	APPROVAL	DATE: 21/Oct./2015	SPECIFICATION No. : BP3595-B-001-E(Lead Free)
/	/	/	REV.B	ROHM Co.,Ltd.

<Specifications (Precautions and Prohibitions)>

- 7) This product is a specification to radiate the radio wave. It is necessary to acquire the attestation of decided Radio Law of each region used to use the equipment that radiates the radio wave.
Please inquire about the attestation of Radio Law that this product acquires.
- 8) Confirm that operation temperature is within the specified range described in the product specification.
- 9) ROHM shall not be in any way responsible or liable for failure induced under deviant condition from what is defined in this document.

● Precautions Regarding Application Examples and External Circuits

- 1) If change is made to the constant of an external circuit, please allow a sufficient margin considering variations of the characteristics of the Products and external components, including transient characteristics, as well as static characteristics.
- 2) You agree that application notes, reference designs, and associated data and information contained in this document are presented only as guidance for Products use. Therefore, in case you use such information, you are solely responsible for it and you must exercise you own independent verification and judgment in the use of such information contained in this document. ROHM shall not be in any way responsible or liable for damages, expenses or losses incurred by you or third parties arising from the use of such information.

● Precaution for Electrostatic

This Product is electrostatic sensitive product, which may be damaged due to electrostatic discharge. Please take proper caution in your manufacturing process and storage so that voltage exceeding Products maximum rating will not be applied to Products. Please take special care under dry condition (e.g. Grounding of human body / equipment / solder iron, isolation from charged objects, setting of Ionizer, friction prevention and temperature / humidity control).

● Precaution for Storage / Transportation

- 1) Product performance and soldered connections may deteriorate if the Products are stored in the places where:
 - [a] the Products are exposed to sea winds or corrosive gases, including Cl₂, H₂S, NH₃, SO₂, and NO₂
 - [b] the temperature or humidity exceeds those recommended by ROHM
Temperature: 5°C~40°C, Humidity 40%~60%
 - [c] the Products are exposed to direct sunshine or condensation
 - [d] the Products are exposed to high Electrostatic
- 2) Even under ROHM recommended storage condition, connector mating of products over 1 year old may be degraded.
- 3) Store / transport cartons in the correct direction, which is indicated on a carton as a symbol. Otherwise bent leads may occur due to excessive stress applied when dropping of a carton.

● Precaution for product label

QR code printed on ROHM product label is for ROHM's internal use only, and please do not use at customer site.

● Precaution for disposition

When disposing Products please dispose them properly using an authorized industry waste company.



<Specifications (Precautions and Prohibitions)>

● Precaution Regarding Intellectual Property Rights

- 1) All information and data including but not limited to application example contained in this document is for reference only. ROHM does not warrant that foregoing information or data will not infringe any intellectual property rights or any other rights of any third party regarding such information or data.
- 2) ROHM shall not have any obligations where the claims, actions or demands arising from the combination of the Products with other articles such as components, circuits, systems or external equipment (including software)
- 3) No license, expressly or implied, is granted hereby under any intellectual property rights or other rights of ROHM or any third parties with respect to the Products or the information contained in this document. Provided, however, that ROHM will not assert its intellectual property rights or other rights against you or your customers to the extent necessary to manufacture or sell products containing the Products, subject to the terms and conditions herein.

● Other Matters

- 1) This document may not be reprinted or reproduced, in whole or in part, without prior written consent of ROHM.
- 2) The Products may not be disassembled, converted, modified, reproduced or otherwise changed without prior written consent of ROHM.
- 3) In no event shall you use in any way whatsoever the Products and the related technical information contained in the Products or this document for any military purposes, including but not limited to, the development of mass-destruction weapons.
- 4) The proper names of companies or products described in this document are trademarks of registered trademarks of ROHM, its affiliated companies or third parties.

1. STRUCTURE

P.C.BOARD ASSEMBLY

2. PRODUCTS

HYBRID INTEGRATED CIRCUIT

3. TYPE

BP3595

4. APPLICATION

COMMUNICATION APPLIANCE

5. FUNCTION

WIRELESS LAN COMMUNICATION

6. ABSOLUTE MAXIMUM RATINGS

No.	PARAMETER	SYMBOL	LIMITS	UNIT	REMARKS
1	Power supply voltage	VCC	-0.3 ~ +3.6	V	DC
2	Operating temperature range	Topr	-40 ~ +85	°C	No condensation
3	Storage temperature range	Tstg	-40 ~ +85	°C	No condensation

Note) These are the values that must not be exceeded at any time under any application or any test conditions.
 Please make design keeping enough margins accordingly.

7. RECOMMENDED OPERATING CONDITIONS

No.	PARAMETER	SYMBOL	SPEC			UNIT	REMARKS
			MIN.	TYP.	MAX.		
1	Power supply voltage	VCC	3.1	3.3	3.5	V	-
2	Operating temperature range	Ta	-40	25	85	°C	-

8. MAIN CHARACTERISTICS

No.	PARAMETER	CHARACTERISTICS
1	Frequency width	2,400MHz ~ 2,483.5 MHz (ch1~ch13)
2	Frequency tolerance	Within ± 25 ppm
3	RF output power (*1)	IEEE802.11b : 15dBm \pm 2dB IEEE802.11g : 13dBm \pm 2dB IEEE802.11n : 12dBm \pm 2dB
4	Supported data rates	IEEE802.11b : 1 ~ 11Mbps IEEE802.11g : 6 ~ 54Mbps IEEE802.11n : 6.5 ~ 72.2Mbps
5	Receiving sensitivity (*1)	IEEE802.11b : -94dBm @1Mbps, -89dBm @11Mbps IEEE802.11g : -92dBm @6Mbps, -73dBm @54Mbps IEEE802.11n : -90dBm @6.5Mbps, -68dBm @72.2Mbps
6	Security function	64bit/128bit WEP, TKIP, AES (*2)
7	Host Interface	USB2.0 (High-Speed mode) SDIO Ver.2.00 (High-Speed mode) UART (~921600bps)
8	Power supply voltage	SINGLE 3.3V

(*1) "RF output power" and "Receiving sensitivity" are performance value that is at the electricity supplying point for antenna in the below figure.

(*2) 64bit/128bit WEP, TKIP, and AES are everything processed with hardware.

9. BLOCK DIAGRAM

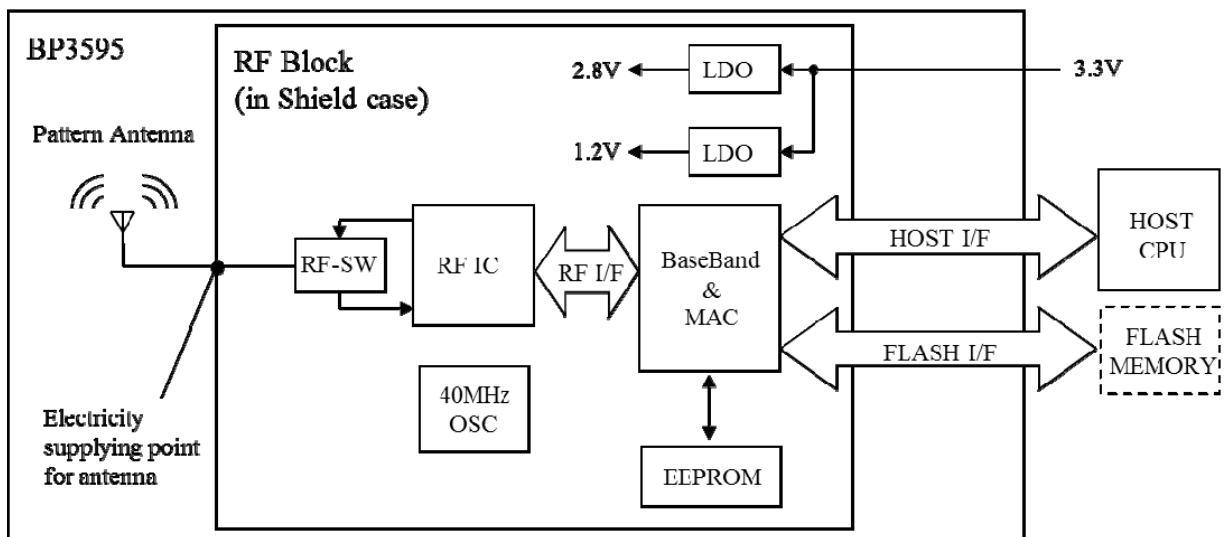

Fig 1. Block diagram

- A Flash memory (option) is necessary for use the flash boot function.

10. ELECTRICAL CHARACTERISTICS

CONDITIONS : Ta=25°C, VCC=3.3V, GND=0.0V

No.	PARAMETER	CONDITION	SPEC			UNIT	REMARKS
			MIN.	TYP.	MAX.		
1	Consumption current	Sending	240	300	360	mA	Continuous
			280	340	400	mA	Continuous (With USB)
		Receiving	160	200	240	mA	-
			200	240	280	mA	With USB
		Sleep mode	-	1	-	mA	-
2	Center frequency	-	2412	-	2472	MHz	-
3	Frequency tolerance	-	-25	-	25	ppm	-
4	RF output power	11b : 11Mbps	13	15	17	dBm	At electricity supplying point for antenna
		11g : 54Mbps	11	13	15	dBm	At electricity supplying point for antenna
		11n : MCS7	10	12	14	dBm	At electricity supplying point for antenna
5	Unnecessary out-of-band radiation	-	-	-	2.5	uW/MHz	-
6	Transmit spectrum mask	DSSS 11Mbps	-	-	-30	dBr	1 st Side-lobe
			-	-	-50	dBr	2 nd Side-lobe
		OFDM 54Mbps	-	-	-20	dBr	±11MHz
			-	-	-28	dBr	±20MHz
			-	-	-40	dBr	±30MHz
7	Receiving sensitivity	11b : 11Mbps	-	-89	-76	dBm	PER<8% At electricity supplying point for antenna
		11g : 54Mbps		-73	-65	dBm	PER<10% At electricity supplying point for antenna
		11n : MCS7	-	-68	-64	dBm	PER<10% At electricity supplying point for antenna
8	Unnecessary radiation for receiving	Fr<1GHz	-	-	4	nW	-
		Fr≥1GHz	-	-	20	nW	-

11. TERMINAL FUNCTIONS

Back side

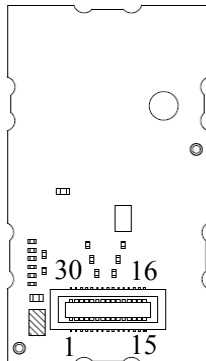

BP3595 Connector (Receptacle) Type

: DF40C-30DS-0.4V(51) (Hirose electric Co., Ltd.)

User-side Connector (Plug) Type

: DF40C-30DP-0.4V(51) (Hirose electric Co., Ltd.)

Table 1. Module Terminal Functions

No.	TERMINAL NAME	I/O	FUNCTIONS	REMARKS
1	BOOT SEL0	I(*)	Boot mode select	(**)
2	GPIO8/32k	I/O	General purpose Input/Output 8	GPIO 8 or 32.768kHz clock input
3	GPIO6	I/O	General purpose Input/Output 6	-
4	GPIO0	I/O	General purpose Input/Output 0	-
5	V28_STBY	I	V28 LDO Stand-by port	Active Hi (VCC Voltage)
6	GPIO2	I/O	General purpose Input/Output 2	-
7	GPIO1	I/O	General purpose Input/Output 1	-
8	V12_STBY	I	V12 LDO Stand-by port	Active Hi (VCC Voltage)
9	UART TXD	O	UART sending data	-
10	UART RXD	I	UART receiving data	-
11	FLASH TXD	I/O	Flash memory sending data	Terminal for flash boot
12	FLASH CLK	O	Flash memory clock	Terminal for flash boot
13	FLASH CSB	O	Flash memory chip select	Terminal for flash boot
14	FLASH RXD	I	Flash memory receiving data	Terminal for flash boot
15	PRST	I	Power on reset	0:Reset, 1:Normal
16	GND	-	Ground	-
17	USB_DM	AI/O	USB data minus	-
18	USB_DP	AI/O	USB data plus	-
19	GND	-	Ground	-
20	SDDATA2	I/O	SDIO data 2	-
21	SDDATA3	I/O	SDIO data 3	-
22	SDCMD	I/O	SDIO command	-
23	VCC	-	Power supply 3.3V	Module power supply input
24	VCC	-	Power supply 3.3V	Module power supply input
25	SDCLK	I	SDIO clock	-
26	SDDATA0	I/O	SDIO data 0	-
27	SDDATA1	I/O	SDIO data 1	-
28	HOST SEL	I(*)	Host I/F select	0:USB, 1:SDIO
29	FLASH SEL	I(*)	Flash memory area select	0:region1, 1:region2
30	BOOT SEL1	I(*)	Boot mode select	(**)

(*) FLASH_SEL/HOST_SEL/BOOT_SEL0/BOOT_SEL1 terminal hold the value after reset (Power On Reset). After reset, these terminals are used for another purpose in the module.

They have pull down resistance inside. Therefore, please set these terminals OPEN in case of setting for "0" and Pull up 3.3V (power supply voltage) with 3kΩ ~ 5kΩ resistor (recommendation is 4.7kΩ resistor) in case of setting for "1".

When the host MCU controls these terminal, please do not connect directly with output terminal of host MCU and insert 3kΩ ~ 5kΩ resistor (recommendation is 4.7kΩ resistor) between them.

When FLASH BOOT function is not used, FLASH_TXD terminal (pin 11) should be connected pull down resistor of 47kΩ.

When FLASH BOOT function is used, FLASH_TXD terminal (pin 11) and FLASH_RXD (pin 14) terminal would be connected pull down resistor, if you need.

PRST is POWER ON RESET terminal. It is connected 4.7kΩ resistor + 2.2uF capacitor at 3.3V inside the module. In case that need to watch the power supply voltage, please connect such as OPEN DRAIN RESET IC for this terminal.

V12_STBY terminal and V28_STBY terminal control LDO which are mounted BP3595.
Hi(VCC voltage): active, Lo(GND):stand-by

Please open the other unused terminals.

(**) BOOT_SEL terminals select the interface to boot the firmware..

BOOT_SEL[1:0]

00:USB, 01:SDIO, 10:FLASH, 11:UART

12. DIMENSIONS

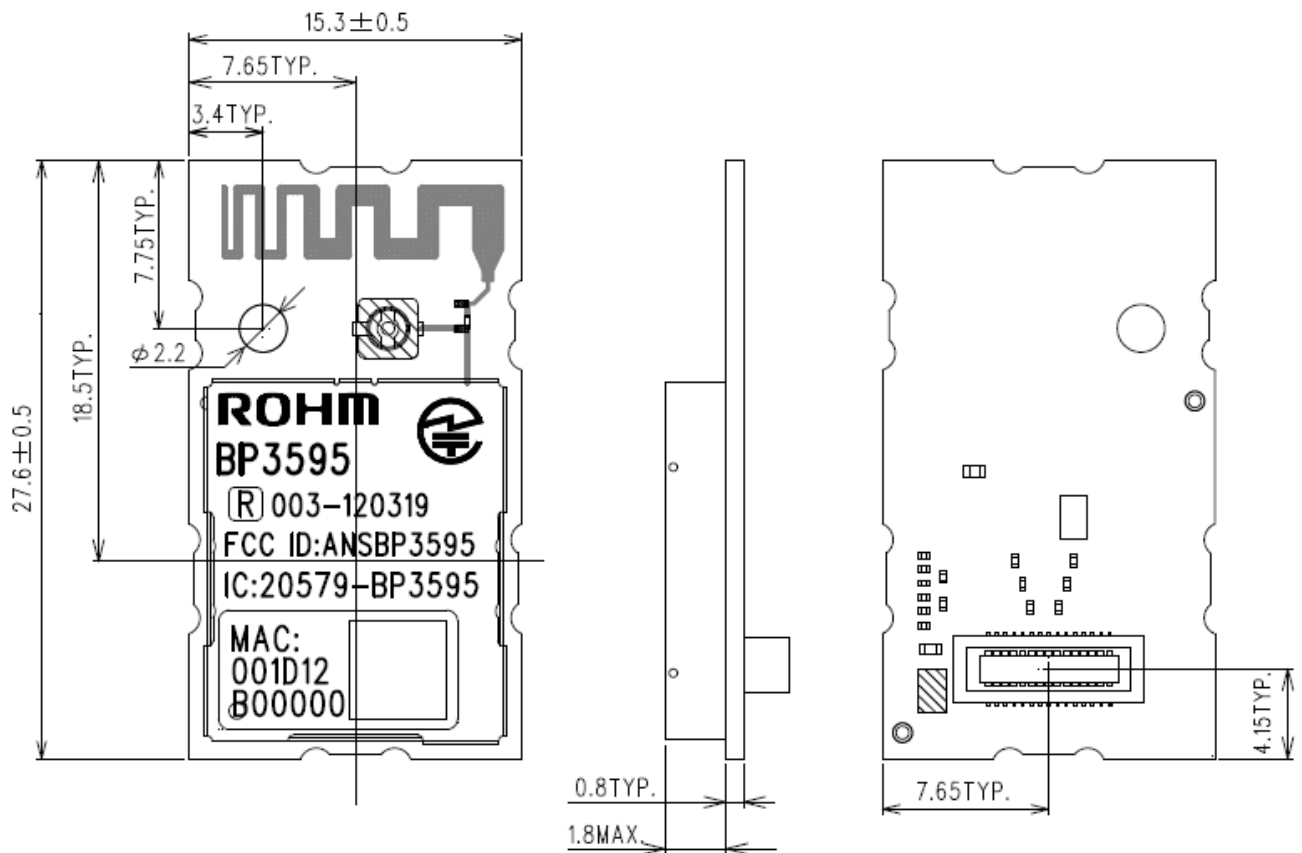

Fig.2 Dimensions (Unit: mm)

13. MARKING SPECIFICATION

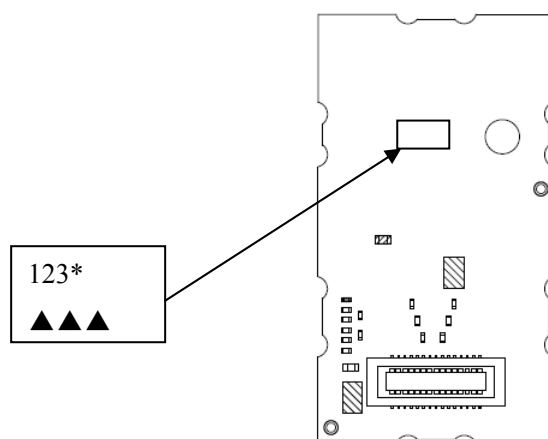

Fig.3 Marking specification (Back side)

Marking

123*: Production lot number (3 digits + 1 internal serial number)
(Example) 123→Year 2011 Week 23th

14. PRECAUTIONS FOR MOUNTING

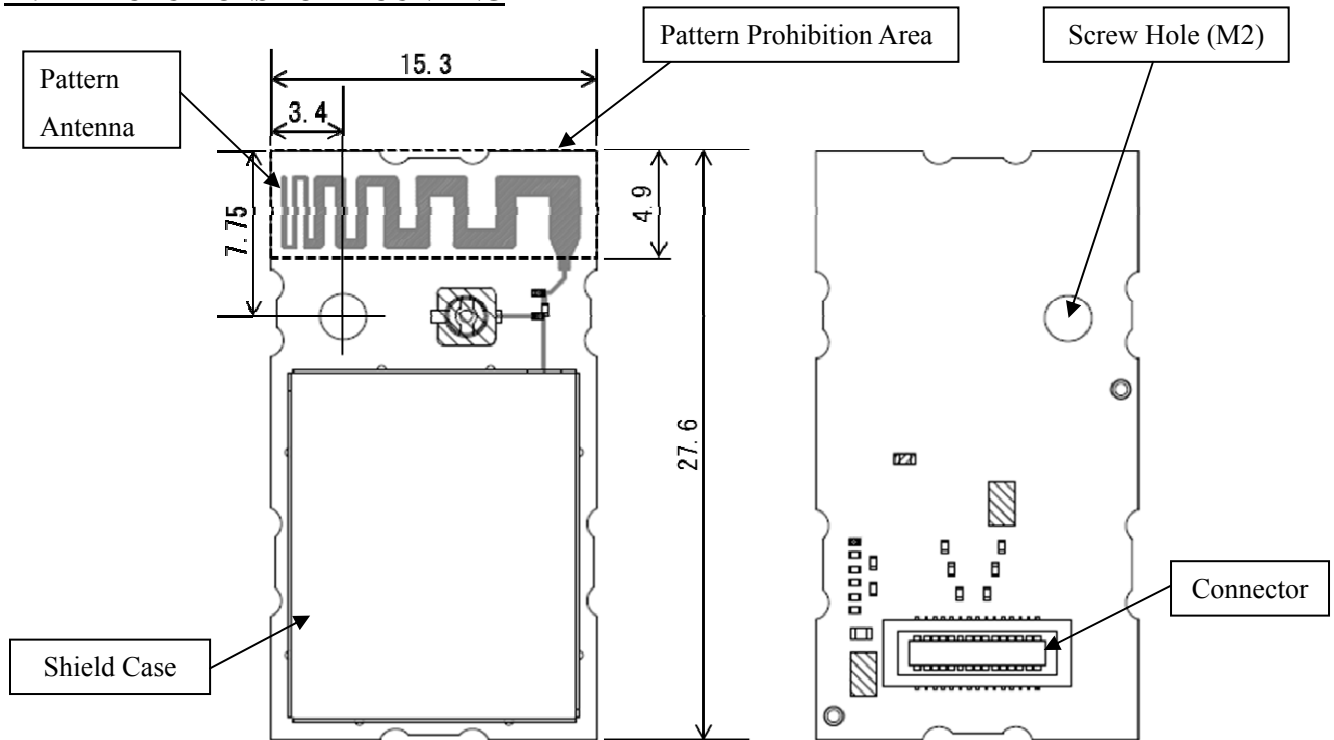

Fig.4 Precautions for Mounting (Unit : mm)

- (1) Please don't patterning the area under "pattern prohibition area" so that there is an adverse effect in a wireless characteristic.
- (2) Please do not set your substrates and chassis around the chip antenna within 1cm.
- (3) Please do not use metals as the material of the chassis.
- (4) Please do not mount parts under this module except a specified connector.

ABOUT THE FIXATION OF THIS MODULE

Please use the M2 screw (made of metal) for fixing BP3595.

M2 screw hole is GND potential of this module, please use the metal spacer of 1.5mm height, between your substrate and this module.

A torque to tighten M2 screw should be more than 1kgf·cm, and do not tighten the screw too much.

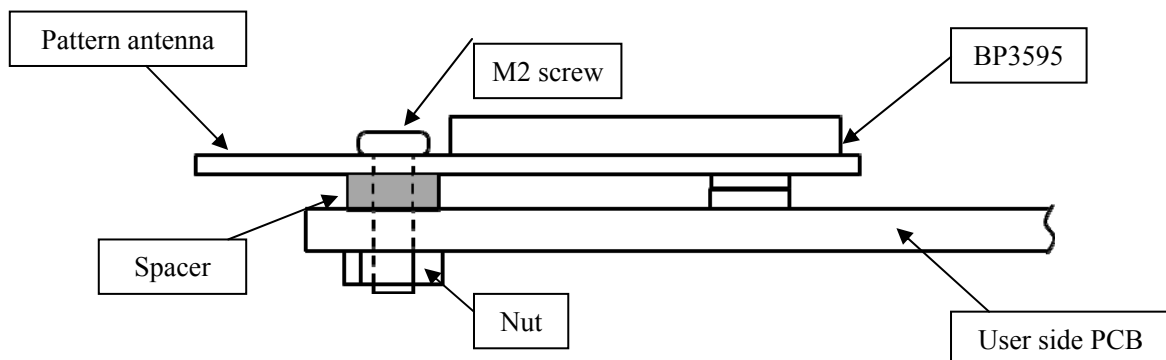

Fig.5 Fixed Module Figure (Side view)

15. PRODUCT LABEL SPEC

The label shown in the following figure is put on the shield case.

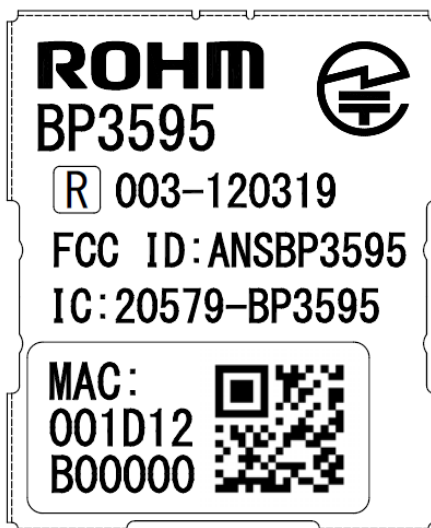

Fig.6 Product Label Spec

*Micro QR code is included in the MAC address information.

(Note)The design of product label might change without previous notice.

16. REFERENCE CIRCUIT

16.1 USB HOST INTERFACE

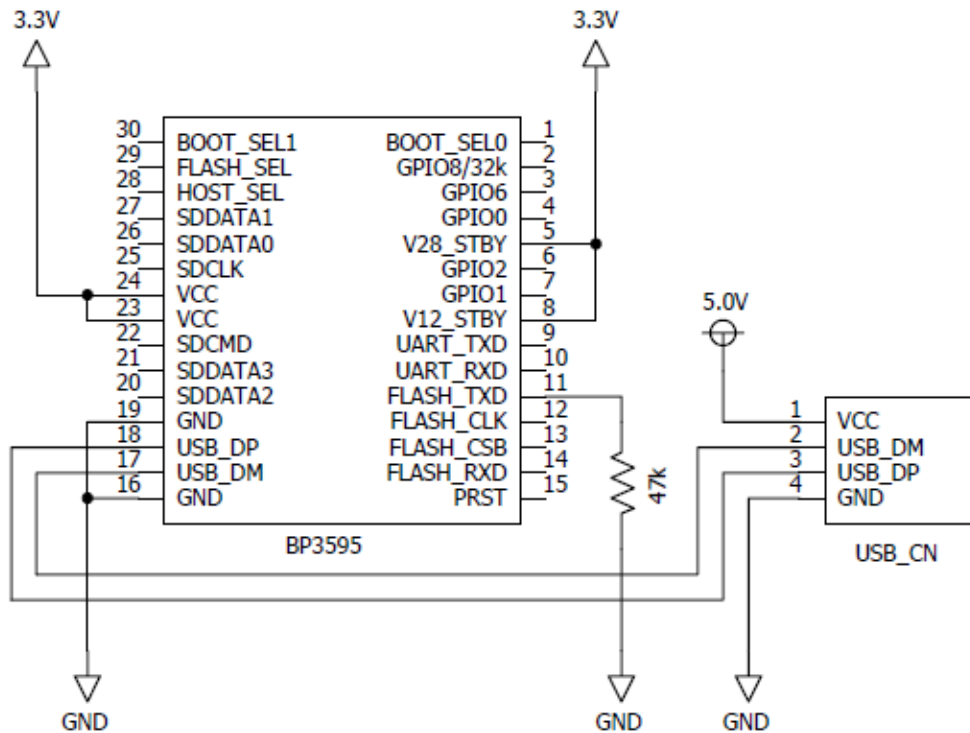

Fig.7 USB Interface Reference Circuit

*About USB_DP and USB_DM Lines

- Please shorten wiring as much as possible.
- Please take the differential impedance matching to $90\Omega \pm 10\%$.
- Please set up to $45\Omega \pm 10\%$ for impedance matching of single end.
- Please wire USB_DP and USB_DM lines as same lengths.
(Difference of the wire length is less than 0.5mm.)
- Please do not bend USB lines many times and make the bend angle small.
- Please do not make thre hole in wiring.
- Please do not cross the USB lines and another signal lines.
- Please do not cross the USB lines and power supply lines.

*Please reduce the ripple of power supply (VCC=3.3V) as much as possible. (less than 10mVpp)

16.2 SDIO HOST INTERFACE

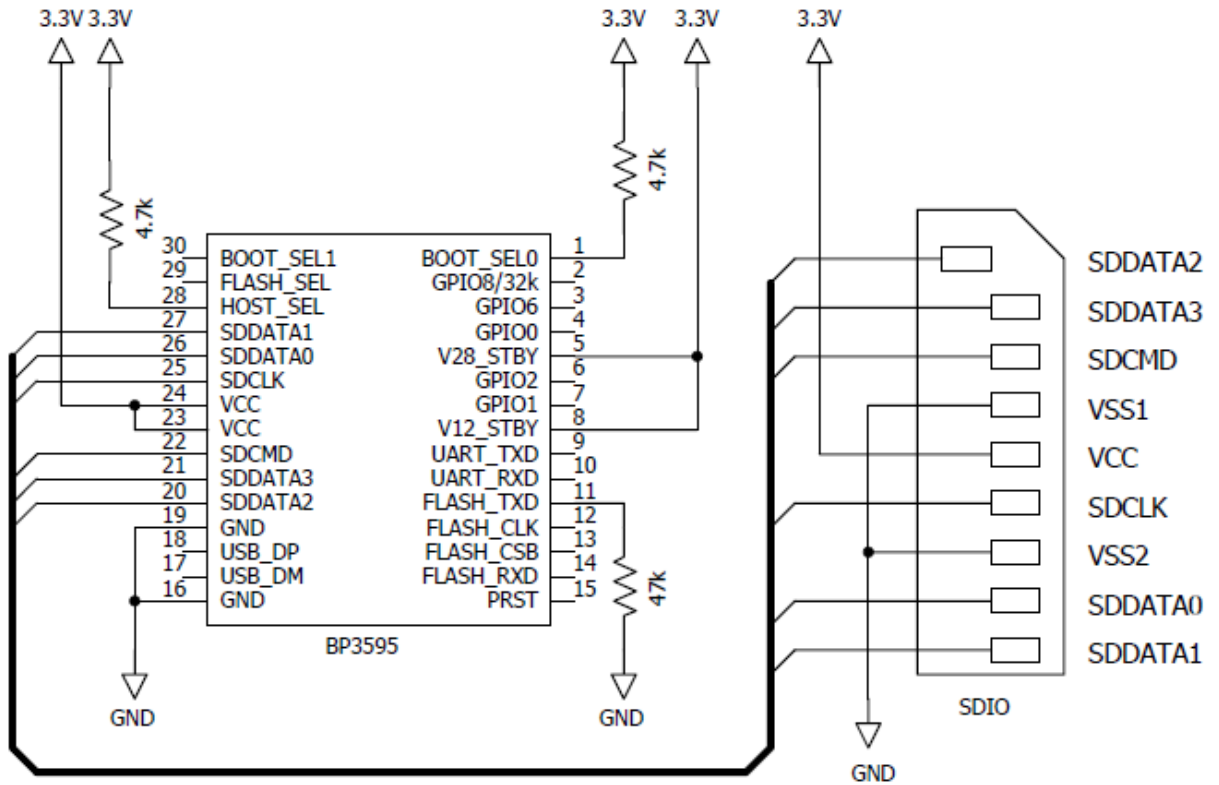

Fig.8 SDIO Interface Reference Circuit

*Please reduce the ripple of power supply (VCC=3.3V) as much as possible. (less than 10mVpp)

*About the line of SDCLK/SDDATA/SDCMD

- Over shoot and under shoot of signal lines cause a lot of damage to wireless performance. Please design your product lower noise levels within the SDIO standard timing. For example it can be insert dumping resistors near the host signal source.

16.3 UART INTERFACE

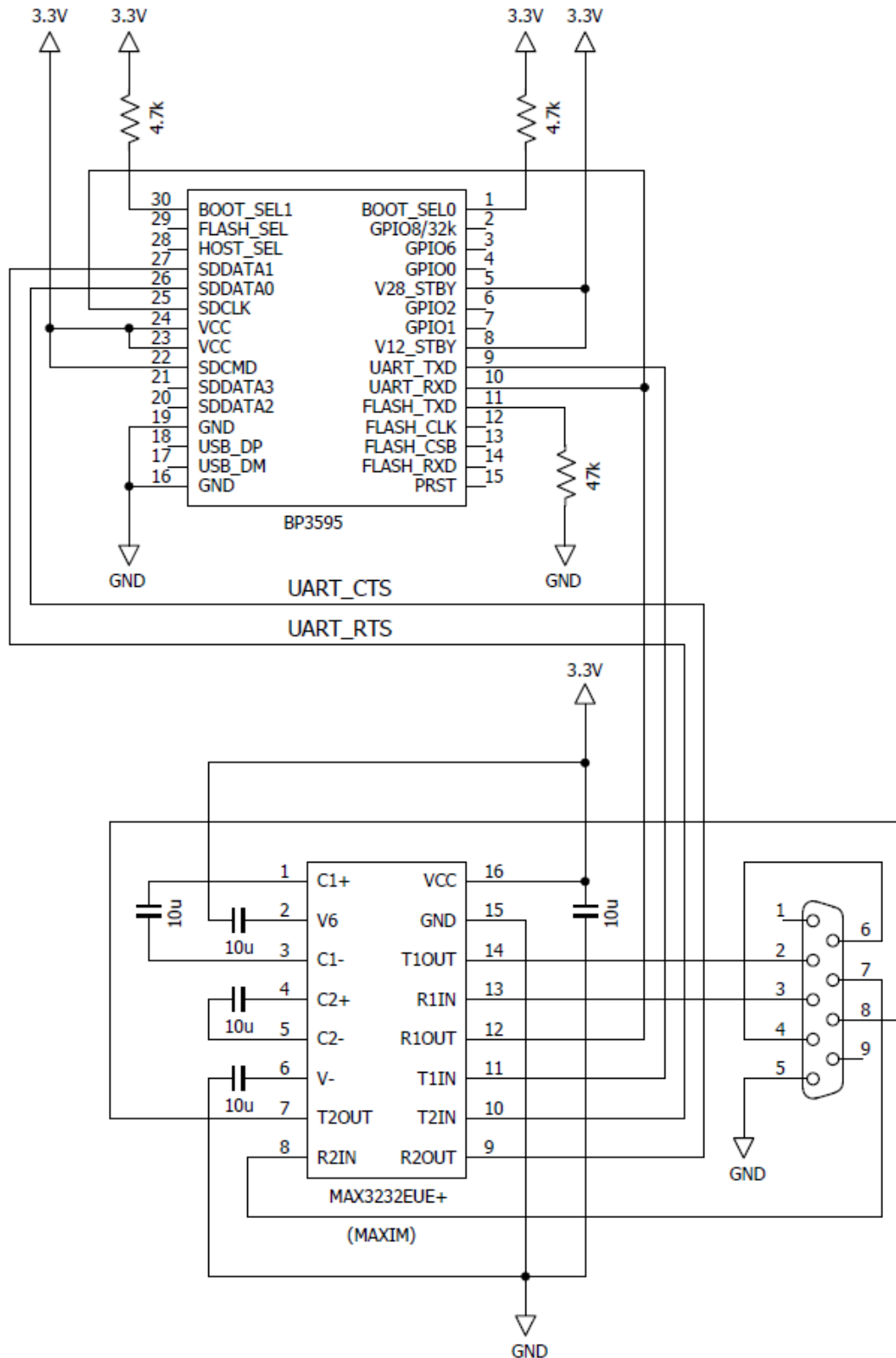

Fig.9 UART Interface Reference Circuit

*Please reduce the ripple of power supply (VCC=3.3V) as much as possible. (less than 10mVpp)

16.4 FLASH BOOT (UART INTERFACE MODE)

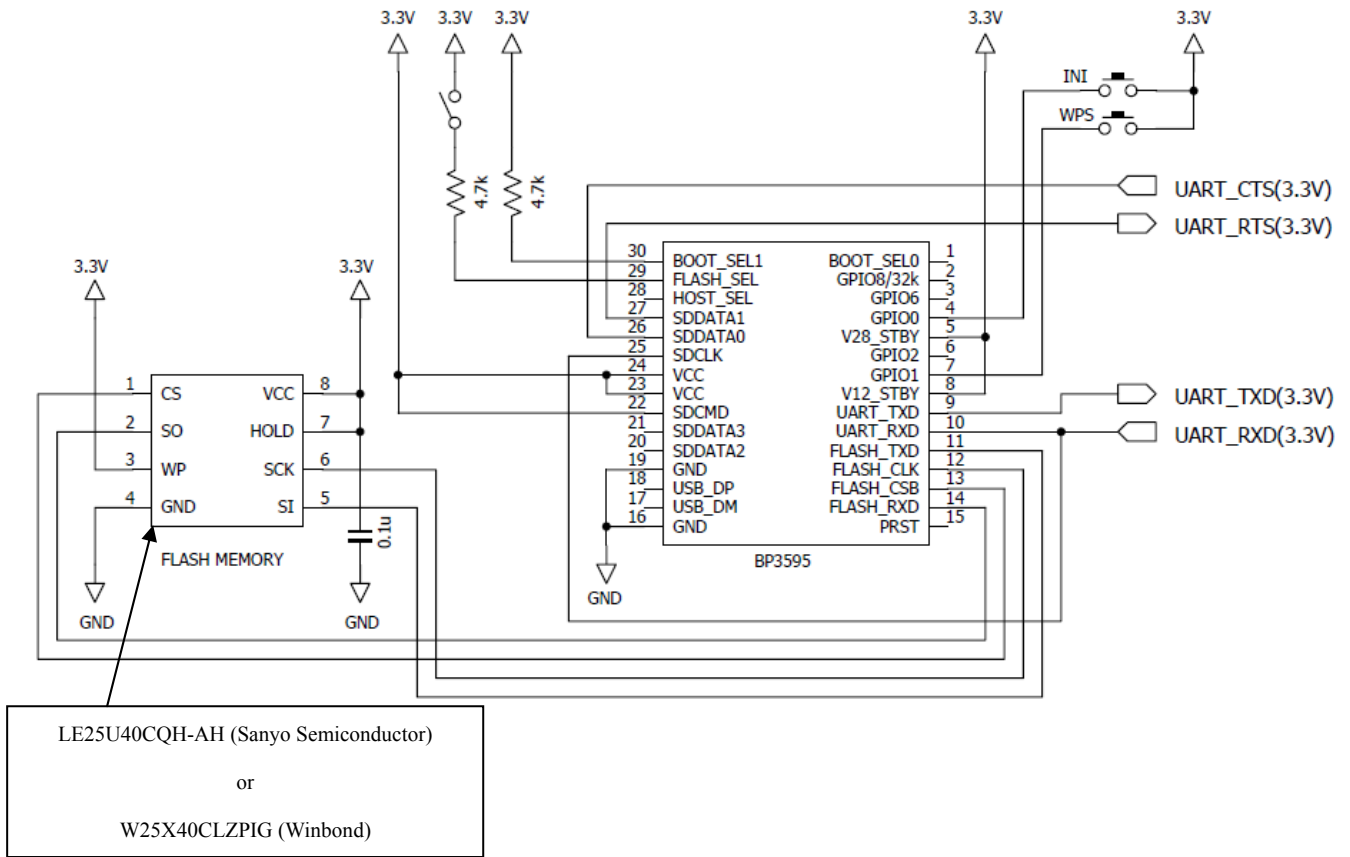

Fig.10 Flash Boot (UART INTERFACE)Reference Circuit

16.5 Reset IC

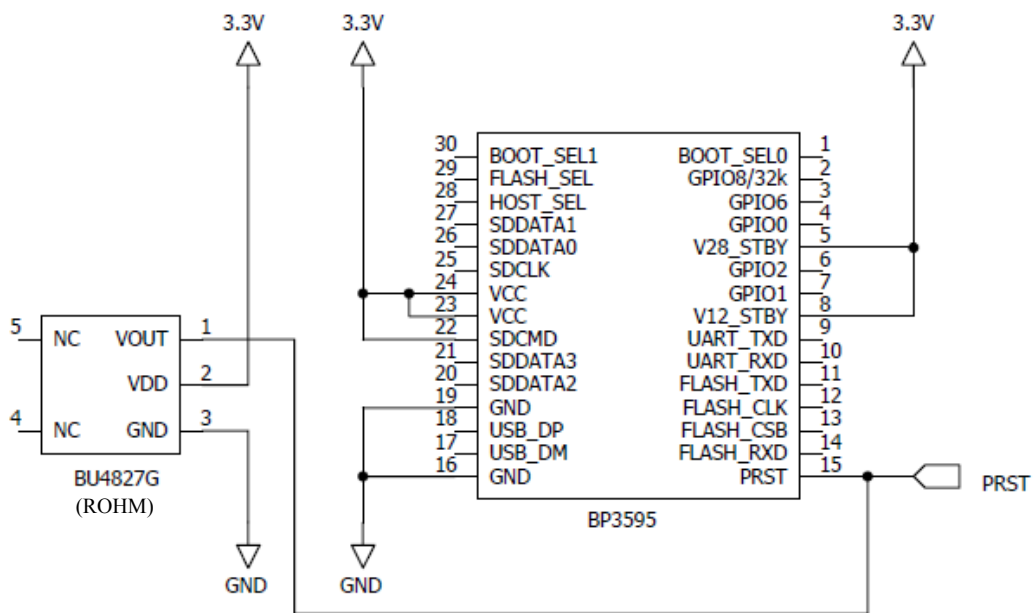

Fig.11 Reset IC Connection Reference Circuit

17. PACKING SPEC

17.1 Packing Method

In principle, 25 pieces of modules should be packaged in the packaging tray, and it should be piled up 12 steps to make 300 pieces, and with an empty pack on the top.
The number of piling might change according to the quantity of delivery without previous notice.

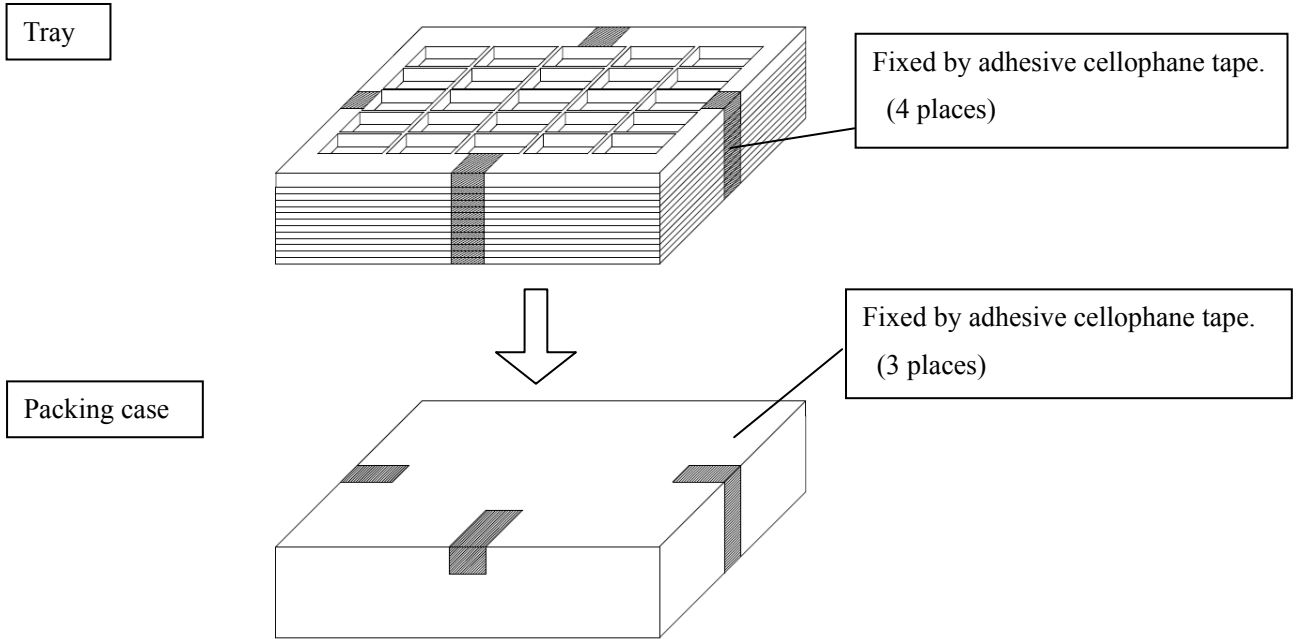

Fig.12 Packing Method

17.2 Label indication

The label with following things is stuck at the packing case.

- ① Type name (BP3595)
- ② Quantity
- ③ Lot No.
- ④ Shipment inspection stamp
- ⑤ Country of origin
- ⑥ Manufacturing company name (Trade mark)
- ⑦ Logotype of lead free

Please refer to the following example of the label indication.



Fig.13 Label Indication

18. MANUFACTURING FACTORY

ROHM APORO CO., LTD. (FUKUOKA, JAPAN)
ROHM ELECTRICS DALIAN CO., LTD. (DALIAN, CHINA)

19. OPERATING PRECAUTIONS

- 1) There is some case that the MAC address does not become sequential number in a same packing.
- 2) About soldering of mounting parts on this product, presence of soldering fillet does not be asked.
- 3) About the products label, deflections does not be asked except coming off, lapping, or not to recognize the characters extremely.
- 4) A connector is possible to break by excessive swing or shock because of the structure of the product.
Efficient evaluation is necessary to use the module when there is a fear of swinging or shocking.
- 5) The connector of BP3595 does not have a specification assumed to do many times of extraction and insertion.
Please be sure that the number of extraction and insertion is within 10 times.

20. PRECAUTIONS AS RESET OPERATION

- Please do not reset (PRST, COMMAND RESET) when BP3595 is accessing to its internal EEPROM.
- BP3595 under writing to the EEPROM is reset (*), which may cause unexpected failure such as incorrect checksum.
- BP3595 under reading from the EEPROM is reset (**), which may cause unstable condition, and you should supply VCC power again.

(*) About write operations of the EEPROM

BP3595 writes to the EEPROM in the following cases.

- ① Recording various settings used in TCP/IP firmware
- ② Recording credential data which is obtained when BP3595 with stand-alone mode acts WPS

() About read operations of the EEPROM**

BP3595 reads from the EEPROM in the following cases.

- ① After reset (≤ 100 ms)
- ② After firmware starting (≤ 100 ms)
- ③ When WID_SERIAL_NUMBER command is issued.

21. PRECAUTIONS AS A WIRELESS EQUIPMENT 1

BP3595 acquired "Construction design attestation" (Article 38-24, Clause1 of Radio Law in Japan) of "Particular wireless equipment: Low power data communications system in the 2.4GHz band, which is a Wireless equipment in Article 2-1(19)"

Therefore, only in Japan, it is possible to use as wireless equipment without applying for wireless office.

- Construction design attestation No. : 003-120319

Be sure to keep following notes to use the module safely as wireless equipment.

- 1) The label on the module is a certification which shows it has "Certification of technical standard conformity."
Please do not remove the label or do not put another label on the label.
- 2) Please do not resolve or remodel strictly because there are some cases of receiving penalty based on Radio Law in Japan.

22. PRECAUTIONS AS A WIRELESS EQUIPMENT 2

BP3595 acquired radio law certified in U.S.A (Federal Communications Commission Part15 Subpart C).
BP3595 is able to use in U.S.A without application of FCC.

- FCC ID: ANSBP3595

Please following the below precautions for using BP3595 as wireless equipment in U.S.A.

- 1) The label on the product is a certification label shown to be acquiring "FCC certification".
Please do not put another label on the label.
- 2) If FCC ID is displayed on BP3595 cannot be seen from the outside of your product, the following displays (*) are needed for your product including BP3595.

"Contains Transmitter Module FCC ID: ANSBP3595"

or

"Contains FCC ID: ANSBP3595"

- (*) The character size can be read easily is required. However it is not required more than 8 points.
And also line break is not permit.

- 3) It is necessary to display the following texts on your product. (*)

This device complies with part 15 of the FCC Rules. Operation is subject to the following two conditions: (1) This device may not cause harmful interference, and (2) this device must accept any interference received, including interference that may cause undesired operation.

- (*) If the text cannot be displayed on your product, you should describe in a manual or a package. It is foundations that the text is indicated on your product.

- 4) It is necessary to indicate all the texts applicable to the manual of your product.
① It is necessary text for all products.

FCC CAUTION

Change or modifications not expressly approved by the party responsible for compliance could void the user's authority to operate the equipment.

- ② It is necessary text for all products . 2

This transmitter must not be co-located or operated in conjunction with any other antenna or transmitter.

- ③ It is necessary text for mobile product or portable product.

A SAR examination is not required at mobile products (*) but is required at portable products (**).

(*) Mobile product The product is used separating from a human body over 20 cm.

(**) Portable product The product is used by human body within 20cm.

- ③-1 It is necessary texts for a mobile product that is not required SAR examination if it is used by human body within 20cm.

This equipment complies with FCC radiation exposure limits set forth for an uncontrolled environment and meets the FCC radio frequency (RF) Exposure Guidelines. This equipment has very low levels of RF energy that it deemed to comply without maximum permissive exposure evaluation (MPE). [※But it is desirable that it should be installed and operated keeping the radiator at least 20cm or more away from person's body.]

- ③-2 It is necessary texts for a mobile product that is required SAR examination if it is used by human body within 20cm.

This equipment complies with FCC radiation exposure limits set forth for an uncontrolled environment and meets the FCC radio frequency (RF) Exposure Guidelines. This equipment should be installed and operated keeping the radiator at least 20cm or more away from person's body (※) .

(※) It is necessary text for the product which is examined Hand SAR or uses always in hand but lower than limit of Hand SAR.

“excluding extremities: hands, wrists, feet and ankles”

- ③-3 It is necessary texts for a portable product that is not required SAR examination.

This equipment complies with FCC radiation exposure limits set forth for an uncontrolled environment and meets the FCC radio frequency (RF) Exposure Guidelines. This equipment has very low levels of RF energy that are deemed to comply without testing of specific absorption rate (SAR).

③-4 It is necessary texts for a portable product that is required SAR examination.

The available scientific evidence does not show that any health problems are associated with using low power wireless devices. There is no proof, however, that these low power wireless devices are absolutely safe. Low power Wireless devices emit low levels of radio frequency energy (RF) in the microwave range while being used. Whereas high levels of RF can produce health effects (by heating tissue), exposure of low-level RF that does not produce heating effects causes no known adverse health effects. Many studies of low-level RF exposures have not found any biological effects. Some studies have suggested that some biological effects might occur, but such findings have not been confirmed by additional research. [product name (model name)] has been tested and found to comply with FCC radiation exposure limits set forth for an uncontrolled environment and meets the FCC radio frequency (RF) Exposure Guidelines.

23. PRECAUTIONS AS A WIRELESS EQUIPMENT 2

BP3595 acquired radio law certified in Canada (Industry Canada: IC).
BP3595 is able to use in Canada without application of IC.

•IC:20579-BP3595

Please following the below precautions for using BP3595 as wireless equipment in Canada.

- 1) The label on the product is a certification label shown to be acquiring "IC certification". Please do not put another label on the label.
- 2) If IC number is displayed on BP3595 cannot be seen from the outside of your product, the following displays (*) are needed for your product including BP3595.

“Contains Transmitter Module IC:20579-BP3595”

or

“Contains IC:20579-BP3595”

(*) The character size can be read easily is required. However it is not required more than 8 points.

- 3) It is necessary to indicate all the texts applicable to the manual of your product.
- ① It is necessary text for all products.

This device complies with Industry Canada license-exempt RSS standard(s). Operation is subject to the following two conditions: (1) this device may not cause interference, and (2) this device must accept any interference, including interference that may cause undesired operation of the device.

Le présent appareil est conforme aux CNR d'Industrie Canada applicables aux appareils radio exempts de licence. L'exploitation est autorisée aux deux conditions suivantes: (1) l'appareil ne doit pas produire de brouillage, et (2) l'utilisateur de l'appareil doit accepter tout brouillage radioélectrique subi, même si le brouillage est susceptible d'en compromettre le fonctionnement.

(※)It is necessary to shown in English with French.

② It is necessary text for mobile product or portable product.

A SAR examination is not required at mobile products (*) but is required at portable products (**).

(*) Mobile product ... The product is used separating from a human body over 20 cm.

(**) Portable product ... The product is used by human body within 20cm.

②-1 It is necessary texts for a mobile product that is not required SAR examination if it is used by human body within 20cm.

This equipment complies with IC radiation exposure limits set forth for an uncontrolled environment and meets RSS-102 of IC radio frequency (RF) Exposure rules. This equipment has very low levels of RF energy that it deemed to comply without maximum permissive exposure evaluation (MPE). [※But it is desirable that it should be installed and operated keeping the radiator at least 20cm or more away from person's body.]

Cet équipement est conforme aux limites d'exposition aux rayonnements énoncées pour un environnement non contrôlé et respecte les règles d'exposition aux fréquences radioélectriques (RF) CNR-102 de l'IC. Cet équipement émet une énergie RF très faible qui est considérée conforme sans évaluation de l'exposition maximale autorisée.

[※Cependant, il est souhaitable qu'il devrait être installé et utilisé en gardant une distance de 20 cm ou plus entre le dispositif rayonnant et le corps.]

②-2 It is necessary texts for a mobile product that is required SAR examination if it is used by human body within 20cm.

This equipment complies with IC radiation exposure limits set forth for an uncontrolled environment and meets RSS-102 of the IC radio frequency (RF) Exposure rules. This equipment should be installed and operated keeping the radiator at least 20cm or more away from person's body (※).

Cet équipement est conforme aux limites d'exposition aux rayonnements énoncées pour un environnement non contrôlé et respecte les règles d'exposition aux fréquences radioélectriques (RF) CNR-102 de l'IC. Cet équipement doit être installé et utilisé en gardant une distance de 20 cm ou plus entre le dispositif rayonnant et le corps (※).

(※) It is necessary text for the product which is examined Hand SAR or uses always in hand but lower than limit of Hand SAR.

English: "excluding extremities: hands, wrists, feet and ankles"

French: "à l'exception des extrémités : mains, poignets, pieds et chevilles"

②-3 It is necessary texts for a portable product that is not required SAR examination.

This equipment complies with IC radiation exposure limits set forth for an uncontrolled environment and meets RSS-102 of the IC radio frequency (RF) Exposure rules. This equipment has very low levels of RF energy that are deemed to comply without testing of specific absorption rate (SAR).

Cet équipement est conforme aux limites d'exposition aux rayonnements énoncées pour un environnement non contrôlé et respecte les règles d'exposition aux fréquences radioélectriques (RF) CNR-102 de l'IC. Cet équipement émet une énergie RF très faible qui est considérée conforme sans évaluation du débit d'absorption spécifique (DAS).

②-4 It is necessary texts for a portable product that is required SAR examination.

The available scientific evidence does not show that any health problems are associated with using low power wireless devices. There is no proof, however, that these low power wireless devices are absolutely safe. Low power Wireless devices emit low levels of radio frequency energy (RF) in the microwave range while being used. Whereas high levels of RF can produce health effects (by heating tissue), exposure of low-level RF that does not produce heating effects causes no known adverse health effects. Many studies of low-level RF exposures have not found any biological effects. Some studies have suggested that some biological effects might occur, but such findings have not been confirmed by additional research. [product name (model name)] has been tested and found to comply with IC radiation exposure limits set forth for an uncontrolled environment and meets RSS-102 of the IC radio frequency (RF) Exposure rules.

Les connaissances scientifiques dont nous disposons n'ont mis en évidence aucun problème de santé associé à l'usage des appareils sans fil à faible puissance. Nous ne sommes cependant pas en mesure de prouver que ces appareils sans fil à faible puissance sont entièrement sans danger. Les appareils sans fil à faible puissance émettent une énergie radioélectrique (RF) très faible dans le spectre des micro-ondes lorsqu'ils sont utilisés. Alors qu'une dose élevée de RF peut avoir des effets sur la santé (en chauffant les tissus), l'exposition à de faibles RF qui ne produisent pas de chaleur n'a pas de mauvais effets connus sur la santé. De nombreuses études ont été menées sur les expositions aux RF faibles et n'ont découvert aucun effet biologique. Certaines études ont suggéré qu'il pouvait y avoir certains effets biologiques, mais ces résultats n'ont pas été confirmés par des recherches supplémentaires. [product name (model name)] a été testé et jugé conforme aux limites d'exposition aux rayonnements énoncées pour un environnement non contrôlé et respecte les règles d'exposition aux fréquences radioélectriques (RF) CNR-102 de l'IC.

24. IMPORTANT NOTE BOTH FCC AND IC

In the event that some conditions cannot be met (for example co-location with another transmitter), then the FCC / IC authorization is no longer considered valid and the FCC / IC ID cannot be used on the final product. In these circumstances, the OEM integrator will be responsible for reevaluating the end product (including the transmitter) and obtaining a separate FCC / IC authorization. As long as a condition above is met, further transmitter test will not be required. However, the OEM integrator is still responsible for testing their end product for any additional compliance requirements required with this module installed (for example, digital device emissions, PC peripheral requirements, etc.)

25. MANUAL INFORMATION TO THE END USER

The OEM integrator has to be aware not to provide information to the end user regarding how to install or remove this RF module in the user's manual of the end product which integrates this module.
The end user manual shall include all required regulatory information/warning as show in this manual.

26. ANTENNA RESTRICTION

The antenna is designed as permanent attached and no consideration of replacement.