



MBU 400™

Installation Guide

41-001271-00

Rev 00



Aastra Telecom will not accept liability for any damages and/or long distance charges, which result from unauthorized and/or unlawful use. While every effort has been made to ensure accuracy, Aastra Telecom will not be liable for technical or editorial errors or omissions contained within this documentation. The information contained in this documentation is subject to change without notice.



Copyright 2008 Aastra Telecom. www.aastratelecom.com
All Rights Reserved.

Important Safety Instructions

When using your telephone equipment, basic safety precautions should always be followed to reduce the risk of fire, electric shock and injury to persons, including the following:

1. Do not use this product near water, for example, near a bath tub, wash bowl, kitchen sink or laundry tub, in a wet basement or near a swimming pool.
2. Avoid using a telephone (other than a cordless type) during an electrical storm. There may be a remote risk of electric shock from lightning.
3. Do not use the telephone to report a gas leak in the vicinity of the leak.
4. Use only the power cord and batteries indicated in this manual. Do not dispose of batteries in a fire. They may explode. Check with local codes for possible special disposal instructions.

5. CAUTION

RISK OF EXPLOSION IF BATTERY IS REPLACED BY AN INCORRECT TYPE. DISPOSE OF USED BATTERIES ACCORDING TO THE INSTRUCTIONS. USE ONLY WITH BAK, BAK06-AS02-101281 3.7V 650mAh LI-ION RECHARGEABLE BATTERY PACK.

SAVE THESE INSTRUCTIONS

Importantes mesures de sécurité

Certaines mesures de sécurité doivent être prises pendant l'utilisation de matériel téléphonique afin de réduire les risques d'incendie, de choc électrique et de blessures. En voici quelquesunes:

1. Ne pas utiliser l'appareil près de l'eau, p.ex., près d'une baignoire, d'un lavabo, d'un évier de cuisine, d'un bac à laver, dans un sous-sol humide ou près d'une piscine.
2. Éviter d'utiliser le téléphone (sauf s'il s'agit d'un appareil sans fil) pendant un orage électrique. Ceci peut présenter un risque de choc électrique causé par la foudre.
3. Ne pas utiliser l'appareil téléphonique pour signaler une fuite de gaz s'il est situé près de la fuite.
4. Utiliser seulement le cordon d'alimentation et le type de piles indiqués dans ce manuel. Ne pas jeter les piles dans le feu: elles peuvent exploser. Se conformer aux règlements pertinents quant à l'élimination des piles.
5. La socklet-sortie sera installée près de l'équipement et sera facilement accessible

6. ATTENTION

Il y a danger d'explosion s'il y a remplacement incorrect de la batterie. Remplacer uniquement avec une batterie du même type ou d'un type équivalent recommandé par le constructeur. Mettre au rebut les batteries usagées conformément aux instructions du fabricant. (BAK, BAK06-AS02-101281 3.7V 650mAh LI-ION RECHARGEABLE BATTERY PACK).

CONSERVER CES INSTRUCTIONS

Software License Agreement

Aastra Telecom Inc., hereinafter known as “Seller”, grants to Customer a personal, worldwide, non-transferable, non-sub licensable and non-exclusive, restricted use license to use Software in object form solely with the Equipment for which the Software was intended. This Product may integrate programs, licensed to Aastra by third party Suppliers, for distribution under the terms of this agreement. These programs are confidential and proprietary, and are protected as such by copyright law as unpublished works and by international treaties to the fullest extent under the applicable law of the jurisdiction of the Customer. In addition, these confidential and proprietary programs are works conforming to the requirements of Section 401 of title 17 of the United States Code. Customer shall not disclose to any third party such confidential and proprietary programs and information and shall not export licensed Software to any country except in accordance with United States Export laws and restrictions.

Customer agrees to not reverse engineer, decompile, disassemble or display Software furnished in object code form. Customer shall not modify, copy, reproduce, distribute, transcribe, translate or reduce to electronic medium or machine readable form or language, derive source code without the express written consent of the Seller and its Suppliers, or disseminate or otherwise disclose the Software to third parties. All Software furnished hereunder (whether or not part of firmware), including all copies thereof, are and shall remain the property of Seller and its Suppliers and are subject to the terms and conditions of this agreement. All rights reserved.

Customer’s use of this software shall be deemed to reflect Customer’s agreement to abide by the terms and conditions contained herein. Removal or modification of trademarks, copyright notices, logos, etc., or the use of Software on any Equipment other than that for which it is intended, or any other material breach of this Agreement, shall automatically terminate this license. If this Agreement is terminated for breach, Customer shall immediately discontinue use and destroy or return to Seller all licensed software and other confidential or proprietary information of Seller. In no event shall Seller or its suppliers or licensors be liable for any damages whatsoever (including without limitation, damages for loss of business profits, business interruption, loss of business information, other pecuniary loss, or consequential damages) arising out of the use of or inability to use the software, even if Seller has been advised of the possibility of such damages.

FCC Information

Contact your System Administrator or Technical Support for any questions regarding your MBU 400. Have your serial number and MAC address ready when contacting support. You can locate the serial number and MAC address on the bottom of the MBU. For inquiries concerning telephony services, contact your Internet Telephony Service Provider. For inquiries concerning your broadband connection, contact your Internet Service Provider (ISP), and for inquiries concerning on-screen information services, contact your information services provider.

For the EU: The telephone's conformity with EU directives is confirmed by the CE symbol. We hereby declare that the MBU and/or the Aastra 420d Handset are in compliance with the essential requirements and other relevant provisions of Directive 1999/5/EC.

For the US: This equipment complies with Part 15 of the FCC rules and Part 68 of the FCC rules, and the requirements adopted by the Administrative Council for Terminal Attachments (ACTA). Located on the equipment is a label that contains, among other information, the FCC registration number, and the ringer equivalence number (REN). If requested, this information must be provided to the telephone company.

The REN is used to determine the number of devices which may be connected to the telephone line. Excessive RENs on the telephone line may result in devices not ringing in response to an incoming call. In most, but not all areas, the sum of the RENs should not exceed five (5.0). To ascertain the number of devices that may be connected to the line, as determined by the total RENs, contact the telephone company to determine the maximum REN for the calling area.

This equipment cannot be used on the telephone company-provided coin service. Connection to Party Line Service is subject to State Tariffs.

If this equipment causes harm to the telephone network, the telephone company will notify you in advance that temporary discontinuance of service may be required. If such advance notice is not practicable, the telephone company will notify the customer as soon as possible. Also, you will be advised of your right to file a complaint with the FCC if you believe this is necessary.

The telephone company may make changes in its facilities, equipment, operations, or procedures that could affect the operation of the equipment. If this happens, the telephone company will provide advance notice to enable you to make the necessary modifications in order to maintain uninterrupted service. If the trouble is causing harm to the telephone network, the telephone company may request you to disconnect the equipment from the network until the problem is resolved.

This equipment uses the following USOC jacks: RJ11C.

It is recommended that the customer install an AC surge arrester in the AC outlet to which this device is connected. This is to avoid damage to the equipment caused by local strikes of lightning and other electrical surges.

This product is manufactured for Aastra Telecom, Inc. Copyright© 2008. All rights reserved. Any copying or reproduction of the product or its associated user manual is strictly prohibited. The content of this document is subject to change without prior notice.

US Service Center:

Aastra Telecom US - Service Center
900 Technology Park Drive
Billerica, MA, 01821, USA
Phone (978) 262-3200

For Industry Canada: “This product meets the applicable Industry Canada technical specifications.”

Before installing this equipment, users should ensure that it is permissible to be connected to the facilities of the local telecommunications company. The equipment must also be installed using an acceptable method of connection. In some cases, the company’s inside wiring associated with a single line individual service may be extended by means of a certified connector assembly (telephone extension cord). The customer should be aware that compliance with the above conditions may not prevent degradation of service in some situations.

Repairs to certified equipment should be made by an authorized Canadian maintenance facility designated by the supplier. Any repairs or alterations made by the user to this equipment, or equipment malfunctions, may give the telecommunications company cause to request the user to disconnect the equipment.

Users should ensure for their own protection that the electrical ground connections of the power utility, telephone lines and internal metallic water pipe system, if present, are connected together. This precaution may be particularly important in rural areas.

CAUTION: Users should not attempt to make such connections themselves, but should contact the appropriate electric inspection authority, or electrician, as appropriate.

“The Ringer Equivalence Number is an indication of the maximum number of terminals allowed to be connected to a telephone interface. The termination on an interface may consist of any combination of devices subject only to the requirement that the sum of the Ringer Equivalence Numbers of all the devices does not exceed five.”

Le présent matériel est conforme aux spécifications techniques applicables d'Industrie Canada. L'indice d'équivalence de la sonnerie (IES) sert à indiquer le nombre maximal de terminaux qui peuvent être raccordés à une interface téléphonique. La terminaison d'une interface peut consister en une combinaison quelconque de dispositifs, à la seule condition que la somme d'indices d'équivalence de la sonnerie de tous les dispositifs n'excède pas 5.

Consumer Information

- a) This equipment complies with Part 68 of the FCC rules and the requirements adopted by the ACTA. On the back of this equipment is a label that contains, among other information, a product identifier in the format US:T7HIP06B8015. If requested, this number must be provided to the telephone company.
- b) An applicable certification jacks Universal Service Order Codes (USOC) for the equipment is provided (i.e., RJ11C) in the packaging with each piece of approved terminal equipment.
- c) A plug and jack used to connect this equipment to the premises wiring and telephone network must comply with the applicable FCC Part 68 rules and requirements adopted by the ACTA. A compliant telephone cord and modular plug is provided with this product. It is designed to be connected to a compatible modular jack that is also compliant. See installation instructions for details.
- d) The REN is used to determine the number of devices that may be connected to a telephone line. Excessive RENs on a telephone line may result in the devices not ringing in response to an incoming call. In most but not all areas, the sum of RENs should not exceed five (5.0). To be certain of the number of devices that may be connected to a line, as determined by the total RENs, contact the local telephone company. [For products approved after July 23, 2001, the REN for this product is part of the product identifier that has the format US:T7HIP06B8015. The digits represented by ## are the REN without a decimal point (e.g., 06 is a REN of 0.6). For earlier products, the REN is separately shown on the label.]

- e) If this equipment MBU 400 causes harm to the telephone network, the telephone company will notify you in advance that temporary discontinuance of service may be required. But if advance notice isn't practical, the telephone company will notify the customer as soon as possible. Also, you will be advised of your right to file a complaint with the FCC if you believe it is necessary.
- f) The telephone company may make changes in its facilities, equipment, operations or procedures that could affect the operation of the equipment. If this happens the telephone company will provide advance notice in order for you to make necessary modifications to maintain uninterrupted service.
- g) Should you experience trouble with this equipment, please contact: Aastra Telecom US – Service Centre, 900 Technology Part Drive, Billerica, MA, 01821, USA, Phone (978) 262-3200, for repair or warranty information. If the equipment is causing harm to the telephone network, the telephone company may request that you disconnect the equipment until the problem is resolved.
- h) Please follow instructions for repairing if any (e.g. battery replacement section); otherwise do not alternate or repair any parts of device except specified.
- i) Connection to party line service is subject to state tariffs. Contact the state public utility commission, public service commission or corporation commission for information.
- j) **NOTICE:** If your home has specially wired alarm equipment connected to the telephone line, ensure the installation of this 1.9GHz DECT Product for VoIP and PSTN does not disable your alarm equipment. If you have questions about what will disable alarm equipment, consult your telephone company or a qualified installer.
- k) This equipment is hearing aid compatible.

NOTICE: According to telephone company reports, AC electrical surges, typically resulting from lightning strikes, are very destructive to telephone equipment connected to AC power sources. To minimize damage from these types of surges, a surge arrester is recommended.

Applicable for Coin or Pay Phone Only

To comply with state tariffs, the telephone company must be given notification prior to connection for customer-owned coin or credit card phone. In some states, the state public utility commission, public service commission or corporation commission must give prior approval of connection.

Safety Information

Important Safety Information

Charge the battery or handset only in combination with 420d Charger and the SALOM SSW-1444 adapter that comes with the product. Plug the SALOM SSW-1444 AC/DC adaptor in a wall outlet socket near the equipment for easy access/removal of the AC/DC adaptor.

Important Battery Information

This product uses rechargeable Lithium-ion batteries 3.7V, 650mAh. Only use batteries that come with the handset or dedicated spare batteries marked with “Battery Pack 3.7V 650mAh Li-ion”. Do not use any other type, since this may present a risk of leakage, fire, explosion or other hazardous situation. For battery replacement or removal please remove the battery cover of the handset. Never disassemble, customize or short-circuit batteries. Do not place battery in fire or heat the battery. Charge the battery or handset only in combination with 420d Charger and the SALOM SSW-1444 adapter that comes with the product.

Sensitive Electronic Environment

Any radio-based equipment can potentially cause interference with other equipment and can be interfered from other equipment. This also applies for DECT equipment. However due to the very low transmission power level the chances for interference are very small. Research proves that operational DECT phones normally don't influence electronic equipment however some precautions must be taken into account for sensitive electronic equipment e.g. sensitive laboratory equipment. When DECT phones operate in straight nearness of sensitive electronic equipment incidental influence can appear. You are advised not to place the DECT phone on or close (less than 10cm) to this kind of equipment, even in standby mode. Please also use the other documentation supplied with the various parts of your telephone system.

Product Disposal Information

For countries in the European Union



The symbol depicted here has been affixed to your product in order to inform you that electrical and electronic products should not be disposed of as municipal waste.



Electrical and electronic products including the cables, plugs and accessories should be disposed of separately in order to allow proper treatment, recovery and recycling. These products should be taken to a designated facility where the best available treatment, recovery and recycling techniques are available. Separate disposal has significant advantages: valuable materials can be re-used and it prevents the dispersion of unwanted substances into the municipal waste stream. This contributes to the protection of human health and the environment.

Please be informed that a fine may be imposed for illegal disposal of electrical and electronic products via the general municipal waste stream. In order to facilitate separate disposal and environmentally sound recycling, arrangements have been made for local collection and recycling. In case your electrical and electronic products need to be disposed of please refer to your supplier or the contractual agreements that your company has made upon acquisition of these products.

For countries outside the European Union

Disposal of electrical and electronic products in countries outside the European Union should be done in line with the local regulations. If no arrangement has been made with Aastra or your supplier, please contact the local authorities for further information.

Battery Disposal Information

Defect or exhausted batteries should never be disposed of as municipal waste. Return old batteries to the battery supplier, a licensed battery dealer or a designated collection facility. Do not incinerate batteries.

Regulatory Information

Europe

Declaration of Conformity

Hereby, “Aastra Telecom”, declares that this “MBU 400” is in compliance with the essential requirements and other relevant provisions of Directive 1999/5/EC.

Aastra Telecom, Inc.
155 Snow Blvd.
Concord, Ontario
Canada L4K 4N9



United States

Interference Information:

This device complies with Part 15 of the FCC Rules. Operation is subject to the following two conditions: (1) this device may not cause harmful interference, and (2) this device must accept any interference received, including interference that may cause undesired operation.

NOTE: This equipment has been tested and found to comply with the limits for a Class B digital device, pursuant to Part 15 of the FCC Rules. These limits are designed to provide reasonable protection against harmful interference in a residential installation. This equipment generates, uses and can radiate radio frequency energy and, if not installed and used in accordance with the instructions, may cause harmful interference to radio communications. However, there is no guarantee that interference will not occur in a particular installation. If this equipment does cause harmful interference to radio or television reception, which can be determined by turning the equipment off and on, the user is encouraged to try to correct the interference by one or more of the following measures:

- Reorient or relocate the receiving antenna.
- Increase the separation between the equipment and receiver.
- Connect the equipment into an outlet on a circuit different from that to which the receiver is connected.
- Consult the dealer or an experienced radio/TV technician for help.

WARNING: Changes or modifications to this equipment not expressly approved by the party responsible for compliance could void the user’s authority to operate the equipment.

Privacy of communications may not be ensured when using this phone.

Exposure to Radio Frequency (RF) Signals:

This wireless phone is a radio transmitter and receiver. It is designed and manufactured not to exceed the emission limits for exposure to radio frequency (RF) energy set by the Federal Communications Commission (FCC) of the U.S. Government. These limits are part of comprehensive guidelines and establish permitted levels of RF energy for the general population. The guidelines are based on the safety standards previously set by both U.S. and international standards bodies. These standards include a substantial safety margin designed to assure the safety of all persons, regardless of age and health. This device and its antenna must not be co-located or operating in conjunction with any other antenna or transmitter.

This product has been shown to be capable of compliance for localized specific absorption rate (SAR) for uncontrolled environment/general population exposure limits specified in ANSI/IEEE Std. C95.1-1992 and had been tested in accordance with the measurement procedures specified in FCC/OET Bulletin 65 Supplement C (2001) and IEEE 1528-2003” .

CAUTION: To maintain the compliance with the FCC’s RF exposure guideline, place the base unit at least 20 cm from nearby persons. For body worn operation, this handset has also been tested and meets the FCC RF exposure guideline when used with the Aastra belt clip supplied for this product. Use of other accessories may not ensure compliance with FCC RF exposure guidelines.

Hearing Aid Compatibility (HAC/VC):

This handset meets the FCC standard for Hearing Aid Compatibility.

Canada

Interference Information:

Operation is subject to the following two conditions: (1) this device may not cause harmful interference, and (2) this device must accept any interference received, including interference that may cause undesired operation.

Privacy of communications may not be ensured when using this equipment.

Exposure to Radio Frequency (RF) Signals:

This wireless phone is a radio transmitter and receiver. It is designed and manufactured not to exceed the emission limit for exposure to radio frequency (RF) energy set by the Ministry of Health (Canada), Safety Code 6.

These limits are part of comprehensive guidelines and established permitted levels of RF energy for the general population. These guidelines are based on the safety standards previously set by international standard bodies. These standards include a substantial safety margin designed to assure the safety of all persons, regardless of age and health.

This device and its antenna must not be co-located or operating in conjunction with any other antenna or transmitter.

This device has been shown to be capable of compliance for localized specific absorption rate (SAR) for uncontrolled environment / general public exposure limits specific in ANSI/IEEE C95.1-1992 and had been tested in accordance with the measurement procedures specified in IEEE 1528-2003.”

For body worn operation, this handset has also been tested and meets the RF exposure limits of IC RSS-102 when used with the belt clip supplied with this product. Use of other accessories may not ensure compliance with IC RSS-102 RF exposure limits.

This Class B digital apparatus complies with Canadian ICES-003.

Cet appareil numérique de la classe B est conforme à la norme NMB-003 du Canada.

Le présent matériel est conforme aux spécifications techniques applicables d'Industrie Canada.

Hearing Aid Compatibility (HAC/VC):

This handset meets the IC CS-03 issue 9 Part V standard for Hearing Aid Compatibility.

Table of Contents

Important Safety Instructions	iii
Importantes mesures de Sécurité	iii
Software License Agreement	v
FCC Information	vi
Consumer Information	viii
Safety Information	x
Important Safety Information	x
Important Battery Information.....	x
Sensitive Electronic Environment.....	x
Product Disposal Information.....	x
Battery Disposal Information.....	xi
Regulatory Information	xii
Europe	xii
United States	xii
Canada.....	xiii
Congratulations	1
About This Guide	2
Documentation.....	2
MBU 400 Features	3
MBU Features	3
Aastra 420d Handset Features	4
Requirements	5
What's in the MBU 400 Box?	6
MBU 400 Hardware	7
Aastra 420d Handset - Front View.....	7
Aastra 420d Handset - Side View	8
Aastra 420d Handset Charger - Front View.....	9
Aastra 420d Handset Charger - Rear View.....	9
MBU - Top View.....	10
MBU - Rear View	10
Installing the MBU 400	11
Installing on a Desktop	11
Installing on a Wall	12
Installation sur un mur	13
Connecting the MBU 400	14
Installing and Registering the Handset	16
Optional MBU and Handset Tasks	19

Resetting the MBU	19
Manually Registering/De-registering a Handset.....	19
Registering Additional Handsets with the MBU	20
Factory Defaulting the MBU	20
Viewing the MBU 400 IP Address and Status Information	21
Accessing the MBU 400 Web UI.....	22
Using the MBU 400	24
Handset Idle Screen	24
Idle Mode Options	25
Handset Main Menu.....	26
Using the Volume Control.....	28
Using the Speakerphone	28
Locking/Unlocking the Keypad.....	28
Troubleshooting.....	29
Index.....	Index-1

Congratulations!

And thank you for choosing Aastra Telecom's MBU 400.

The MBU 400 consists of a Mobility Base Unit (MBU) and the Aastra Digital Enhanced Cordless Telephone (DECT) handset (420d) that provide telephony service over the Internet and over the Public Service Telephone Network (PSTN) or landlines. You can install the MBU on a desktop or on a wall, while the 420d handset sits in its charging cradle on a desktop. You can register up to 8 handsets with the MBU. The MBU supports up to 3 SIP calls and 1 PSTN call simultaneously.

You can setup your MBU 400 in your business or home environment to act as a small hub with group calling, voicemail, individual SIP accounts, or SIP lines shared across a group. Once installed, the handset(s) can handle all calls for every line (IP calls and PSTN calls). Your System Administrator can configure your phone via a file transfer of a configuration file over TFTP or HTTP, a local web interface, or the handset user interface.

The MBU can be connected to the Internet (service provider required) via an Ethernet cable connected to the LAN port, and/or the PSTN via a regular telephone cable connected to the LINE (or landline) port. The LINE connection also allows for emergency calling and provides the handling of call overflow on the MBU.



Congratulations!

About This Guide

This Installation Guide provides the information required to install and quickly configure the MBU 400 on your business or home network. It includes a description of the features and functions of the MBU and the Aastra 420d Handset. We recommend reviewing the material in this guide before installing the system on your network.

Documentation

The following documentation can be found on the Aastra Telecom website at www.aastratelecom.com:

- ***MBU 400 Installation Guide*** – Contains installation and set-up instructions, general features and functions of the MBU and Handset. This Installation Guide is included in the box with your MBU 400.
- ***MBU 400 User Guide*** – Describes the most commonly used features and functions for an end user. Provides brief configuration information.
- ***MBU 400 Administrator Guide*** – Contains advanced Administrator information and procedures for setting up and using the MBU and Aastra 420d Handset. It also includes advanced configuration information. This Administrator Guide is intended for the System Administrator only.

MBU 400 Features

The MBU 400 provides the following features.

MBU Features

Call and Telephony Features

- VoIP calling (based on SIP 2.0 - RFC3261)
- (optional) Landline calling over Public Service Telephone Network (PSTN)
- Up to 8 paired handsets, one line per handset (MBU supports up to 3 SIP calls and 1 PSTN call simultaneously)
- VoIP DTMF digit support (inband, SIP Info, RFC2833)
- Voicemail support (indicators for receiving and handling of voicemail, and call-to-voicemail server)

Other MBU Features

- System Administrator Web Interface Support (in English only)
- SIP accounts configured via WebUI, TFTP, or from the handset.

Quality of Service

- Type of Service (ToS)

CODECs

- Pulse Code Modulation A-law (PCMA) (G.711, 64 kbps)
- Pulse Code Modulation u-law (PCMU) (G.711, 64 kbps)
- iLBC (20 ms)
- G.729

Maintenance, administration, and provisioning

- DECT interface
- Firmware updates via:
 - Over-the-air programming
 - File transfer of a configuration file over TFTP or HTTP, local Web interface, or the handset user interface (System Administrator PIN required)
- Provisioning allowed via a configuration file, Web interface, or the handset user interface*
- Debug and SIP trace report ability (via Web interface)

* The configuration file provisioning allows full access to all configuration parameters. The local Web interface allows access to only a limited set of configuration settings. The handset user interface enables access to some VoIP account settings (access is controlled by a System Administrator PIN code).

Aastra 420d Handset Features

Display

- 128 x 128 pixels, 65K color support, backlight
- Graphical menu system

Call and Telephony Features

- 12 numerical keys, 5 navigation keys, 2 function keys
- Auto answer (when handset is lifted from the charger)
- Key lock option
- Call forward - all, busy, no answer
- Call timer
- Call transfer and call hold (for internal calls)
- Call waiting indication
- Caller ID with name from phone book
- Distinctive ringing
- Call log of incoming/outgoing/missed calls
- Call return (from call log)
- Customizable phone settings
- Intercom (handset to handset through MBU)
- Contact List (up to 200 entries and up to 4 numbers per entry)
- Voicemail message support
- Speed dial support
- Three-way conferencing (2 handsets)
- Call hang up (upon return to charging cradle)
- On-hook dialing (pre-dial numbers before pressing off-hook button)

Audio Features

- Mute (disable microphone)
- Receiver volume control
- Ring tone melodies
- Ringer volume control
- Key sounds (click, DTMF, and special tones)
- Low battery and out-of-range audible warnings
- Speakerphone
- Headset jack (2.5 mm)

Other Handset Features

- Separate charging station for handset
- Hearing aid compatible
- Multi-language support (Danish, German, English, Spanish, French, Italian, Dutch, Portuguese, Finnish)
- Li-Ion battery pack
- Automatic or fixed registration of handset to MBU
- Status indicators in idle mode (signal, battery level, date and time)
- Message waiting indicator (missed calls, voicemail)
- Vibrator mode on handset

Requirements

Before installing the MBU 400 on your network, the following may be required depending on your network connection:

- Broadband Internet connection – cable, DSL, or equivalent
- Internet Telephony Service Provider subscription – to make voice calls over your Internet connection
- Analog telephone line subscription – to make ordinary phone calls (and emergency calls) over the LINE port on the MBU (optional)
- In addition, before you start the installation process, the following may be required:
 - (optional) Wired Ethernet router or broadband modem for network and IP connections
 - (required) Power outlets for the MBU and the handset charger
 - (optional) Telephone wall outlet used for landline telephony

What's in the MBU 400 Box?

The following parts are contained in your product packaging. Verify that you have all of the items referenced below. If you are missing parts, please contact your System Administrator.

Note: In addition to the parts below, the MBU 400 includes a wall mounting template, wall mounting screws, and wall anchors.

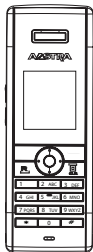

420d Handset



420d Charger Base



Lithium Ion Battery



420d Swivel Belt Clip



420d Charger Base
AC 110/220V
Power Adapter

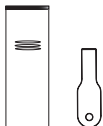

420d Fixed Belt Clip
and Insert Tool



420d Swivel Belt
Clip Attachment

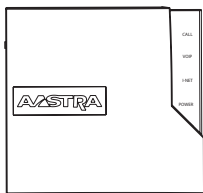

Mobility Base Unit (MBU)



MBU Power Adapter

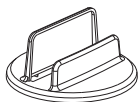

MBU Stand



Ethernet Cable



RJ-11 Telephone Cable



Installation Guide

MBU 400 Hardware

The MBU 400 consists of an MBU and the Aastra 420d Handset. The following illustrations describe the ports, indicators, and keys on the MBU 400 hardware.

Aastra 420d Handset - Front View

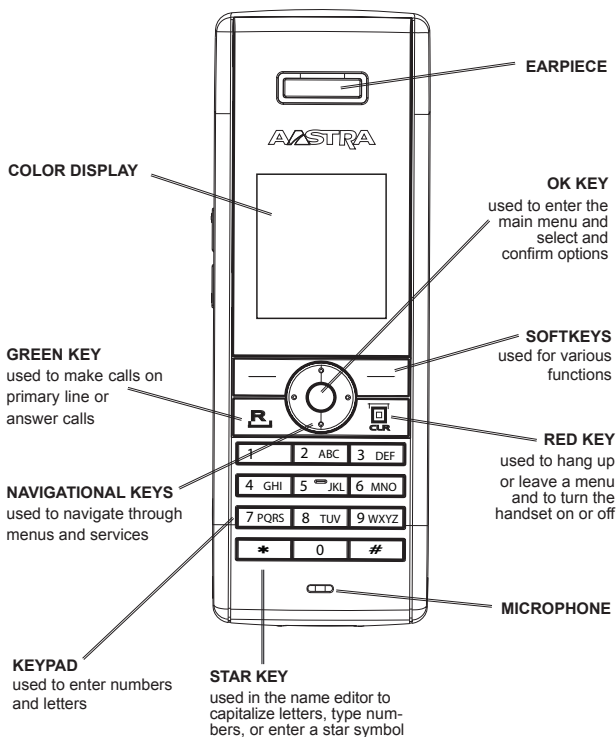

Aastra 420d Handset - Side View

Aastra 420d Handset - Side View

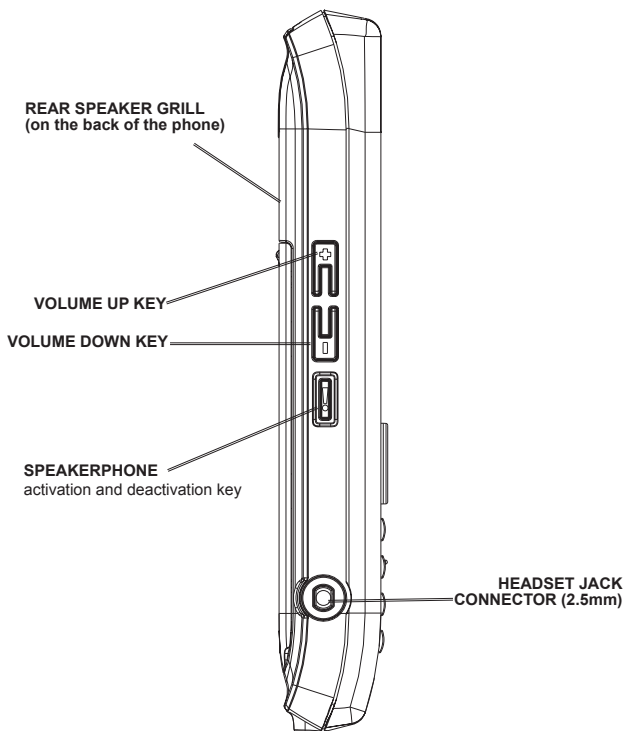

Aastra 420d Handset Charger - Front View

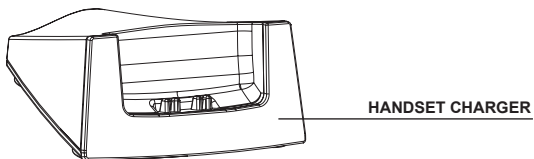

Aastra 420d Handset Charger - Rear View



MBU - Top View

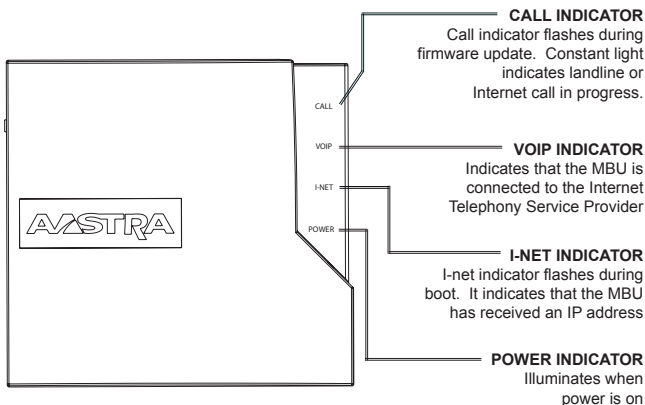

MBU - Rear View

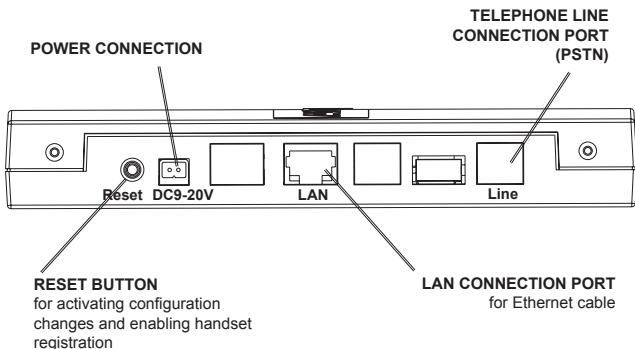

Installing the MBU 400

This section provides procedures for installing your MBU and Aastra 420d Handset.

Before beginning the installation process, review the installation requirements as described in the section, “**Requirements**”, on page 5.

Installing on a Desktop

You can install the MBU on any flat desktop using the MBU stand included with your unit.

To install the MBU 400 on a desktop:

1. Place the MBU stand on a flat surface.
2. Hold the top of the MBU 400 with the back panel facing left.
3. Slide the bottom of the MBU 400 into the stand and push to make sure it is secure.
4. Proceed to “**Connecting the MBU 400**” on page 14 to connect your MBU 400 using the cables provided.

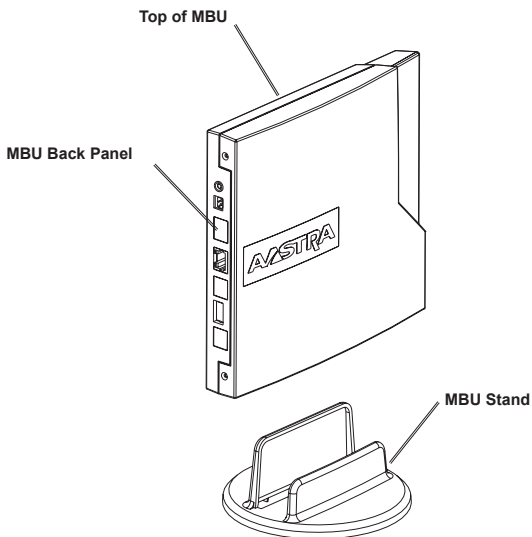

Installing on a Wall

You can install the MBU on a wall if required. The MBU has two pre-drilled wall mounting holes on the back of the unit (see illustration below).

To install the MBU on a wall:

1. Using the wall mount drilling template, locate and mark the position for the mounting screws on the wall. Depending on the wall type, you may need to use the wall anchors. Both the wall mounting screws and wall anchors are included with your MBU.
2. If required, insert the wall anchors into the wall.
3. Insert the screws either into the wall anchors or into the wall (if no wall anchors were required).
4. On the back of the MBU locate the wall mount holes and place these holes over the screw heads on the wall.
5. Pull down and left to lock the unit into place.
6. Proceed to “**Connecting the MBU 400**” on page 14 to connect your MBU using the cables provided.

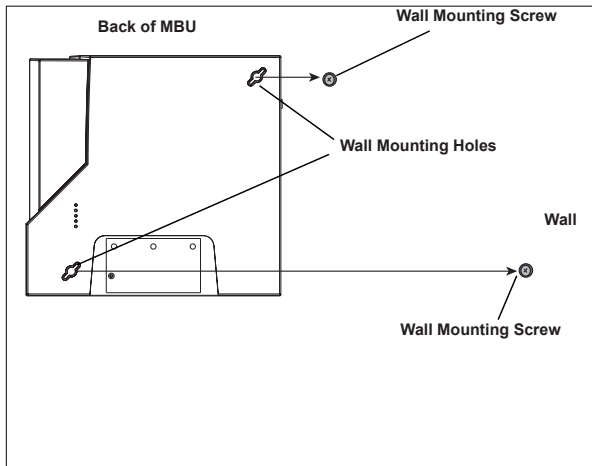

Installation sur un mur

Vous pouvez installer le MBU sur un mur, si nécessaire. Le MBU dispose de deux ouvertures déjà percées au dos de son boîtier en vue d'un montage mural (voir l'illustration ci-dessous).

Pour installer le MBU sur un mur:

1. A l'aide des ouvertures au dos du boîtier, localiser et marquer au mur l'emplacement qu'auront les vis de montage. Suivant le type de mur, vous pourrez avoir besoin d'utiliser les chevilles murales. Les vis de montage et les chevilles murales sont fournies avec le MBU.
2. Si nécessaire, introduisez les chevilles murales dans le mur.
3. Introduisez les vis, soit dans les chevilles, soit dans le mur si les chevilles ne sont pas nécessaires.
4. Repérez les ouvertures de montage mural au dos du MBU et placez les sur les têtes des vis au mur.
5. Tirez le boîtier vers le bas et vers la gauche pour le verrouiller à cette position.
6. Suivez la procédure "Connexion du MBU 400" à la page 14 pour connecter votre MBU en utilisant les câbles fournis.

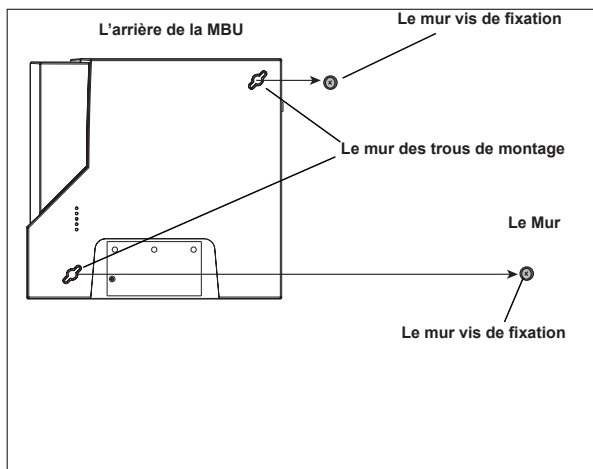

Connecting the MBU 400

1. To prepare the MBU for Internet telephony, connect the Ethernet cable from the LAN port on the MBU to the LAN port on your broadband modem or router.

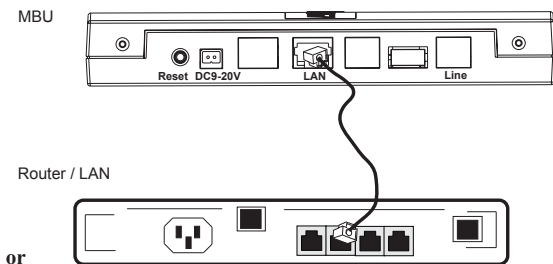

Connect the Ethernet cable from the **LAN** port on the MBU to the Ethernet connection on your network as shown below.

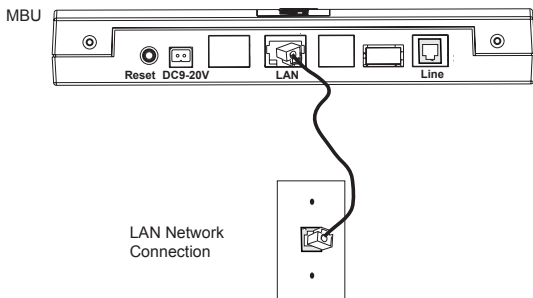

2. To prepare the MBU for analog telephone line calls, connect the telephone cord from the **LINE** port on the MBU to the telephone wall outlet.

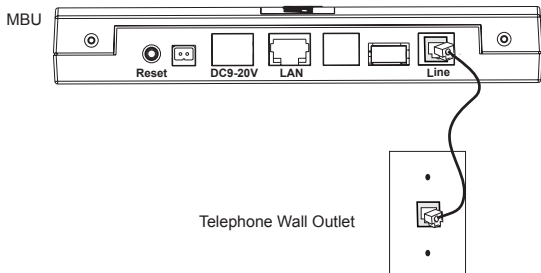

3. Connect the MBU power adapter to the MBU, and plug-in the other end to an active power outlet (preferably a continuous power outlet without a switch to interrupt its power).

MBU

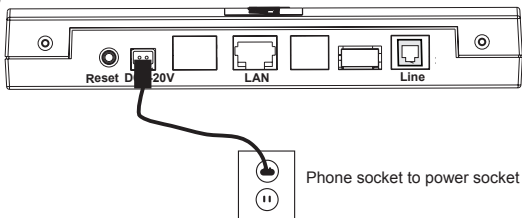

The **POWER** LED on the MBU lights up steady and the **I-NET** LED flashes as the MBU proceeds to power up.

When the power cycle is complete, the **I-NET** LED goes out, the **POWER** LED lights up steady, and then the **I-NET** LED lights up steady indicating the MBU has obtained an IP address and is ready to be configured.

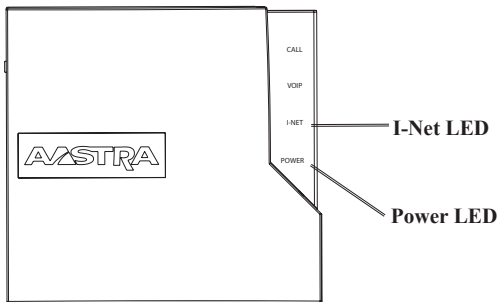

Note: The **Call** LED lights up steady during incoming or outgoing VoIP and landline calls.

Installing and Registering the Handset

1. On the back of the phone, insert your thumbnail into the slot at the bottom of the phone, and pull up.

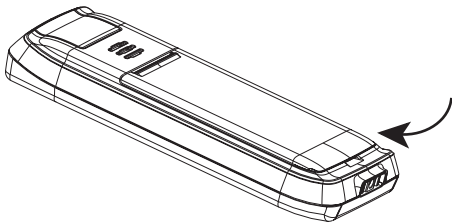

2. Insert the Lithium-ion battery face-up into the handset, making sure that the contacts on the battery connect to the contacts in the body of the phone as shown in the illustration, and then replace the battery cover to the back of the phone.

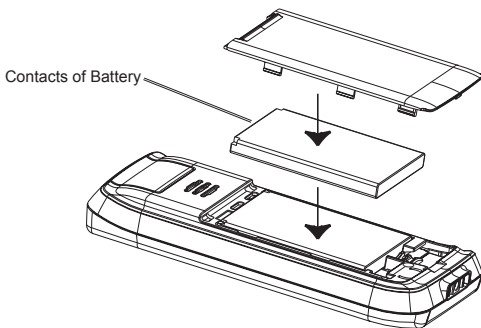

3. Connect the Handset Charger Base Power Adapter to the 420d Handset Charger, and plug-in the other end to an active power outlet (preferably a continuous outlet without a switch to interrupt its power).

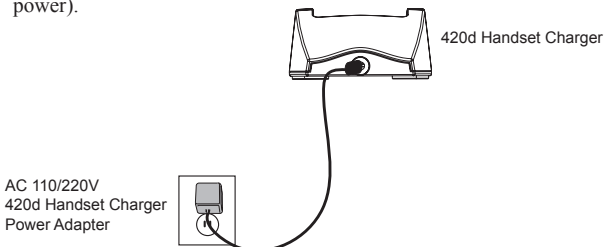

4. Place the handset in the charger, and charge the battery. We recommend that you charge the battery fully before first use. **This takes approximately 10 hours.** When you place the handset in the charger, the handset automatically registers with the MBU, provided you have just reset the MBU. Place the handset near the MBU during the registration process.

Note: After registration of the first handset, there is a 5-minute period during which you can register any additional handsets. If you want to register additional handsets after the 5-minute period has expired, press the **Reset** button once (do not hold down) on the rear of the MBU to start a new 5-minute registration period.



Optional MBU and Handset Tasks

This section provides optional tasks you can perform, if required, on the MBU and Aastra 420d Handset(s).

Resetting the MBU

In order for the handsets to register with the MBU, you must press the **Reset** button on the rear of the MBU. Each time you reset the MBU, the handsets must re-register. Make sure the handset(s) are within range of the MBU for the handset to register properly.

Note: When you reset the MBU, the MBU waits until active calls have been completed on the handsets before starting the reset process. If a registered handset is off during an MBU reset, it reconnects when turned on, as long as the MBU was not factory defaulted.

To reset the MBU:

- Press and release the **Reset** button once (do not hold down) on the rear of the MBU.
The POWER LED lights up steady, and the I-NET LED flashes.
When the reset is complete, the I-NET LED lights up steady, indicating the MBU is ready to use.

Note: Check to be sure all handsets registered (or reconnected) properly with the MBU after the reset is complete.

Manually Registering/De-registering a Handset

If required, you can manually register and deregister a handset. Make sure your handset is within range of the MBU before registering/deregistering your handset.

To register/deregister the handset:

1. In Idle mode, press **OK** to display the Main Menu.
2. Press **Settings**.
3. Select **System Settings**, and press **OK**.
4. Select **Handset Settings**, and press **OK**.
5. To deregister the handset, select **Deregister handset** and press **Yes** at the prompt. The handset prompts to be placed in its charger cradle, so that auto-registration can occur.

- To manually register the handset, select **Settings->System Settings ->Handset Settings->Register handset** and press **Yes** at the prompt. The handset begins the registration process immediately.

Note: If multiple handsets are registered with the MBU, you can also select a specific handset by selecting **Handsets** in the **Handset Settings** menu, choosing the required handset, and pressing the **Register** or **Deregister** softkey.

Registering Additional Handsets with the MBU

You can register additional handsets (up to 8 handsets) with your MBU. Make sure your handsets are within range of the MBU before registering them.

To register additional handsets:

- Press and release the **Reset** button once (do not hold down) on the rear of the MBU.
- Manually De-register the handset being added to initiate the auto-registration process.
- Place the handset in the charger.
When the new handsets have successfully registered, the status indicator in the upper left corner of the screen turns white.

Factory Defaulting the MBU

If required, you can set the MBU back to its factory default settings.

To factory default the MBU:

- Press and HOLD the **Reset** button on the rear of the MBU for approximately 12 seconds, until all the LEDs (Power, I-Net, VOIP, and Call) on the MBU light up at the same time.
- Release the **Reset** button. The LEDs go off as the MBU proceeds to factory default.
When the factory default is complete, the Power LED lights up steady and all other LEDs are off.

Note: Factory defaulting the MBU automatically de-registers all associated handsets. You must manually re-register the handset(s) with the MBU using the procedure in the section, **“Manually Registering/De-registering the Handset”** on page 19.

Viewing the MBU 400 IP Address and Status Information

You can view the MBU 400 IP address and status information from the Handset screen.

To view the IP address and status of the MBU:

1. After pairing the handset to the MBU, press the + (UP) button on the side of the handset to connect to the base.
2. Scroll down to see the IP address and other status information about the MBU.

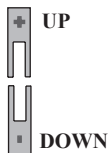

IP Address

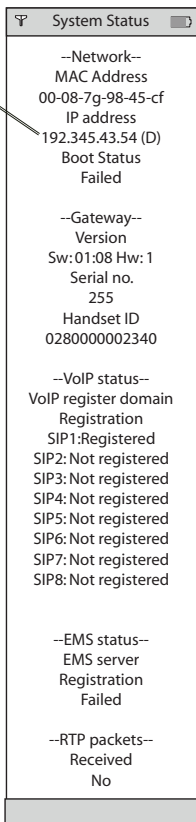

Accessing the MBU 400 Web UI

You can access the MBU 400 Web User Interface using your browser and the IP address of the MBU 400.

To access the MBU 400 Web UI:

1. Open your web browser and enter the MBU's IP address (in dotted decimal format) into the address field, and press **Enter**. (For example, `http://192.168.0.13`.)

Note: To find the IP address of your MBU 400, see “**Viewing the MBU 400 IP Address**,” on page 21.

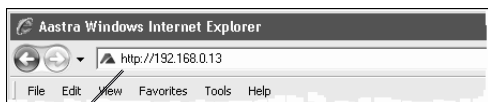

Enter IP Address

The Login window displays.



2. Enter your username and password and click **OK**.

Note: For a user, the default user name is “**admin**” and the password is “**22222**”.

The MBU 400 Welcome screen displays.

AASTRA Mobility Base Unit

Home
VoIP Account 1
VoIP Account 2
VoIP Account 3
VoIP Account 4
VoIP Account 5
VoIP Account 6
VoIP Account 7
VoIP Account 8
Management Settings
NAT/RTP Settings
IP Settings
Pincode Settings
PSTN Settings
Telephony Settings
Time Settings
Debug
SIP Trace
Settings

Welcome

Please select a configuration page in the index pane on left.

System information:

Phone Type: DECT-SIP-Phone
MAC-Address: 00087B074808
IP-Address: 192.168.0.13
Firmware-Version: Aastra-ip8014-DECT-SIP/99.95i/19-Aug-08 20:17
Firmware-URL: http://update.dualphoneonline.com/Updates/Alex-sip8014/

SIP Identity Status:

Identity 1 Status:	@	Not in use
Identity 2 Status:	@	Not in use
Identity 3 Status:	@	Not in use
Identity 4 Status:	@	Not in use
Identity 5 Status:	@	Not in use
Identity 6 Status:	@	Not in use
Identity 7 Status:	@	Not in use
Identity 8 Status:	@	Not in use

If you have changed any settings you need to reboot.
Press button to reboot.

3. To logout, close the browser window.

For more information about using the options in the MBU 400 Web UI, see the *MBU 400 User Guide*, or your System Administrator.

Using the MBU 400

This section briefly describes how to use your MBU 400.

For more detailed information about using the features on your MBU 400, and to customize your Aastra 420d handset, see your *MBU 400 User Guide*. For information about configuring and upgrading your MBU 400, see your *MBU 400 Administrator Guide*.

Handset Idle Screen

After successful registration of the handset to the MBU, the idle screen displays. The following illustration describes the icons that appear on the idle screen.

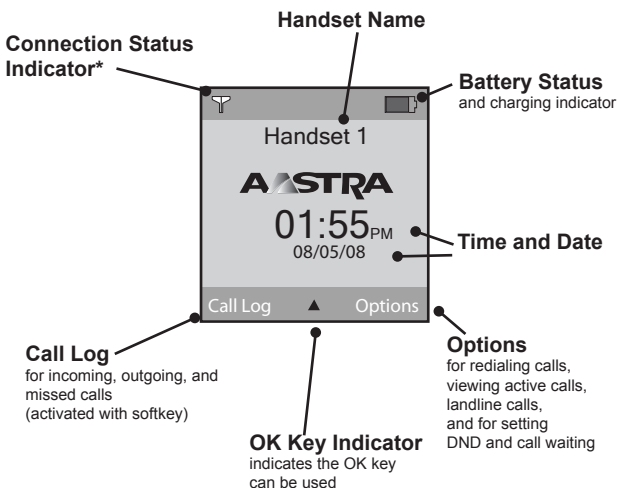

* The following map key shows the various states for the connection status indicator.



Black | Black - Indicates out of range of the MBU



Blue | Black - Indicates within range of the MBU, but not ready for SIP calls



White | White - Indicates within range of the MBU and ready for SIP calls on primary line

Idle Mode Options

When in idle mode, an Options softkey displays in the lower right corner of the screen. Pressing the Options softkey displays the following options:

Idle Mode Options	
Redial	Allows you to redial the last number dialed
Active Calls	Displays the active calls for all handsets registered to the same MBU
Landline	Allows you to place a call using the landline
DND	Allows you to enable/disable Do Not Disturb on your phone
Call Waiting	Allows you to enable/disable Call Waiting on your phone

For more information about using the options softkey in idle mode, see your *MBU 400 User Guide*.

Handset Main Menu

To display the Main Menu on the handset, press the OK button in the center of the navigation keys as shown below.

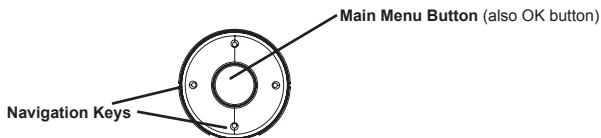

The Main Menu displays. The following illustration describes the icons on the Main Menu screen.

Main Menu

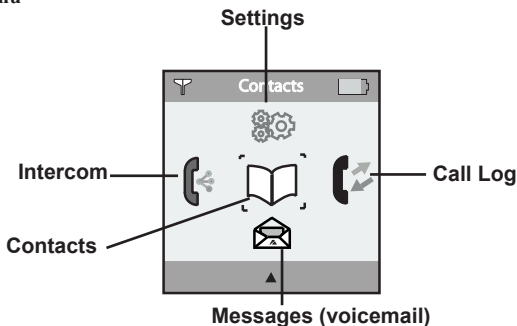

The Handset Main Menu has 5 options you can select to customize and operate the phone.



Intercom - Allows you use the Intercom to communicate between two handsets registered to the same MBU. For more information, see the *MBU 400 User Guide*.



Messages - Allows you to access and play your voicemail messages. Your voicemail service can be provided by your Service Provider or a local mail server. If using a Service Provider for voicemail, contact that provider for more information on how to use your voicemail service. For more information, see the *MBU 400 User Guide*.



Call Log - Allows you to access and view the Call Log which contains a list of all incoming, outgoing, and missed calls. From the Call Log, you can also perform the following:

- Add a selected entry as a contact in the Contact List
- Remove an entry from the Call Log and place it in the Contact List
- Place a call from the entry over a landline
- Place a call from the entry over VoIP
- Edit the entry for placing a call
- Delete a single entry
- Delete all entries

For more information, see the *MBU 400 User Guide*.



Settings - Allows you to customize your phone using the following settings:

- Audio Settings
- Telephony Settings
- VoIP Settings
- Internet Settings
- System Settings

For more information, see the *MBU 400 User Guide*.



Contacts - Allows you to access and view your Contact List. From the Contact List, you can also perform the following:

- Place a call over the landline
- Place a call over VoIP
- Add a contact
- Edit a contact
- Delete a contact
- Delete all contacts
- Set up a speeddial
- Set up a group

For more information, see the *MBU 400 User Guide*.

Using the Volume Control

The volume control is located on the left side of the phone. You can increase or decrease the volume while on an active call as required.

To adjust the volume on the phone:

1. Press the + key to increase the volume as required.
2. Press the - key to decrease the volume as required.

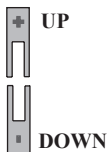

Using the Speakerphone

The speakerphone control is located on the left side of the phone beneath the volume control. You can use the speakerphone key before or during an active call to turn the speakerphone on and off.

To turn the speakerphone on and off:

1. Press the speakerphone key to turn the speakerphone on.
2. Press the speakerphone key again to turn the speakerphone off.



Locking/Unlocking the Keypad

You can lock and unlock the keypad on the phone when required. When locked, it prevents unauthorized users from using your phone, and prevents you from accidentally hitting the keypad if you are carrying the phone around.

To lock the keypad:

1. In Idle Mode, press the “*” key.
2. Press the “Lock” softkey.

To unlock the keypad:

1. To unlock the keypad, press the “*” key.
2. Press the “Unlock” softkey.

Note: The keypad unlocks automatically when you answer an incoming call, or if you make an emergency call. For more information about emergency calls, see the *MBU 400 User Guide*.

Troubleshooting

The following is a list of solutions to the most common issues that you may experience when you install and use the MBU 400. Most of the problems you can easily solve yourself, whereas others require that you contact your service provider. To view the most recently updated troubleshooting information, go to www.aastratelecom.com.

Issue	Causes	Solutions
The handset display is black.	<ol style="list-style-type: none">1) Handset is in power saving mode.2) Batteries are drained.3) Power is not turned on.	<ol style="list-style-type: none">1) Press any key.2) Charge the batteries.3) Check that the batteries are inserted with the plus and minus ends facing the correct way. Press and hold the Red key.
The handset does not charge.	<ol style="list-style-type: none">1) The charger is not powered.2) Batteries are not inserted correctly.	<ol style="list-style-type: none">1) Check that the power cord is connected properly to the charger, and that power is turned on.2) Check that the batteries are inserted with the plus and minus ends facing the correct way.
The handset registration failed, and the status indicator on the display is black.	<ol style="list-style-type: none">1) Handset is out of range of the MBU.	<ol style="list-style-type: none">1) Move the handset closer to the MBU, place it in the charger, and reset the MBU.
The display reads, “Searching for Gateway”.	<ol style="list-style-type: none">1) Handset is out of range of the MBU.2) MBU is not powered.	<ol style="list-style-type: none">1) Move the handset closer to the MBU.2) Plug MBU into a power outlet. (If possible, a continuous power outlet.)

Issue	Causes	Solutions
The POWER indicator on the MBU is not lit.	<ol style="list-style-type: none"> 1) MBU is not powered. 	<ol style="list-style-type: none"> 1) Check that the MBU power cord is connected properly, and that the adapter is plugged into a power outlet. (If possible, a continuous power outlet.)
The I-NET indicator on the MBU is not lit.	<ol style="list-style-type: none"> 1) The Ethernet cable is not connected. 2) The router or modem is not powered. 3) The MBU cannot retrieve an IP address. 	<ol style="list-style-type: none"> 1) Check that the Ethernet cable between the WAN port on the MBU and the LAN port on your modem or router is connected properly. 2) Turn on the power to the modem or router. 3) In Internet settings, check that the IP mode corresponds to the IP mode of your Internet connection.
There is no audio when I make Internet calls.	<ol style="list-style-type: none"> 1) The router blocks audio. 	<ol style="list-style-type: none"> 1) Use port forwarding. Check your router's user manual to see how to configure port forwarding.
I cannot make landline calls.	<ol style="list-style-type: none"> 1) The landline cable is not connected. 2) The landline is out of order. 	<ol style="list-style-type: none"> 1) Check that the landline cable between the Line port on the MBU and the telephone wall outlet is connected properly. 2) Contact your landline provider.

Issue	Causes	Solutions
I cannot receive landline calls.	1) The country setting is wrong.	1) Check that you have chosen the country that you are in. Open the System settings menu, choose Country selection, and then choose the country that you are in.
I cannot make Internet calls, the VoIP indicator on the MBU is not lit, and the right status indicator in the upper left corner of the display is black.	1) The configuration of the phone is not complete. 2) The MBU has not been reset after you saved the configuration. 3) The router uses port forwarding.	1) Check that you have configured your phone properly. Go to www.aastratelecom.com and then click Configuration. For more information, contact your Internet Telephony Service Provider or your System Administrator. 2) Reset the MBU and allow the MBU 2 minutes to log in at your Internet Telephony Service Provider. 3) Check that you have configured your router so that it always assigns the same IP address to your phone's MAC address when using port forwarding. Otherwise incoming traffic is probably not forwarded to your phone. For more information, check your router's manual.

Issue	Causes	Solutions
	<p>4) The router blocks Internet telephony.</p> <p>5) The router firmware needs updating.</p>	<p>4) a) Use port forwarding. The default SIP port is 5060, and the default RTP port is 5004. Ensure that your router always assigns the same IP address to your phone when using port forwarding. For more information, check your router's manual.</p> <p>5) Check your router's user manual to see how to update the firmware.</p>
<p>When I make Internet calls, the sound quality is poor.</p>	<p>1) There is too much simultaneous data traffic on your broadband connection.</p> <p>2) Your Internet Telephony Service Provider's Quality of Service is based on a "best efforts" rather than a guaranteed voice priority method.</p>	<p>1) a) Reduce the amount of traffic on your broadband connection. b) Sign up for a Quality of Service agreement with your broadband provider. c) Order a connection with higher speed from your broadband provider.</p> <p>2) Contact your Internet Telephony Service Provider regarding ensured voice prioritization across the network.</p>

Issue	Causes	Solutions
I cannot make Internet calls, but it worked yesterday.	<ol style="list-style-type: none"> 1) The MBU is not logged in at the Internet Telephony Service Provider. 2) The router is turned off. 3) The SIP server is down. 4) The Internet connection is down. 	<ol style="list-style-type: none"> 1) Check that all cables are connected properly, and check that power is turned on, and then reset the MBU. 2) Turn on the router. 3) Contact your Internet Telephony Service Provider. 4) Contact your broadband provider.
How do I determine the software version of my Handset?	<ol style="list-style-type: none"> 1) I need to know the software version currently installed on my MBU 400. 	<ol style="list-style-type: none"> 1) <ol style="list-style-type: none"> a) Press the + (UP) button on the side of the handset to connect to the base. b) Scroll down to see the Version SW: xx.xx field. <p>For more information about viewing the MBU 400 software version, see “Viewing the MBU 400 IP Address and Status Information” on page 21.</p>

Index

Symbols

- 410d Handset
 - main menu 26
- 420d Handset 7
 - features 4
 - idle mode 25
 - idle screen 24
 - installing 16
 - registering 16
 - registering/de-registering 19
- 420d Handset Charger 9

A

- About This Guide 2
- adding handsets 20

D

- Documentation 2

F

- factory defaulting 20

I

- idle mode, handset 25
- idle screen, handset 24
- Introduction 1
- IP address, finding 21

K

- keypad
 - locking and unlocking 28

M

- main menu, handset 26
- MBU 400
 - about the hardware 7
 - connecting 14
 - features 3
 - hardware included 6
 - installing on a desktop 11
 - installing on a wall 12
 - IP address for 21
 - registering additional handsets 20
 - requirements 5
 - set factory defaults 20
 - status display 21
 - using 24
- MBU gateway 10
- Mesures de Sécurité iii

R

- Regulatory Information xii
- resetting the MBU 19

S

- Safety Information x
 - Battery Disposal Information xi
 - Product Disposal Information x
- Safety Instructions iii
- Software License Agreement v
- speakerphone 28
- status of MBU, finding 21

T

troubleshooting 29

V

volume control 28

W

Web UI, accessing 22

If you've read this owner's manual and consulted the Troubleshooting section and still have problems, please visit our Web site at www.aastratelecom.com, or call 1-800-574-1611 for technical assistance.

© Aastra Telecom Inc. 2008
41-001271-00 Rev 00