

Important Safety Instruction

When using your telephone equipment, basic safety precautions should always be followed to reduce the risk of fire, electric shock and injury to persons, including the following:

- Do not use this product near water, for example, near a bath tub, wash bowl, kitchen sink or laundry tub, in a wet basement or near a swimming pool. Do not allow the handset to come into contact with liquids or moisture.
- Avoid using a telephone (other than a cordless type) during an electrical storm. There may be a remote risk of electric shock from lightning.
- Do not use the telephone to report a gas leak in the vicinity of the leak.
- Use only the power cord and batteries indicated in this manual. Do not dispose of batteries in a fire. They may explode. Check with local codes for possible special disposal instructions.
- Plug the adaptor to the socket-outlet that near the equipment and shall be easily accessible.
- Do not open the handset, base station or charger. This could expose you to high voltage.
- Do not allow the charging contacts of the charger or the battery to come into contact with extraneous conductive materials.
- Young children should be supervised to ensure that they do not play with the telephone.
- Since the phone works by sending radio signals between the base unit and the handset, wearers of hearing aids may experience interference in the form of a humming noise.
- We advise that this phone should not be used near intensive care medical equipment or by persons with pacemakers.
- Your phone can interfere with electrical equipment such as answering machines, TV, and radio sets if placed too close. It is recommended that you position the base unit at least one meter from such appliances.

SAVE THESE INSTRUCTIONS

Accessories & Content

The following items are included in the package of JACOB JENSEN™ Telephone 10, with interchangeable speaker-cover/battery door and country adaptor (optional):

1. Telephone Handset
2. Base Station
3. Table Stand
4. Screws and plugs
5. Power supply unit
6. Li-ion 3.7V 650mAh Battery
7. Combo jack
8. Combo cord.
9. Line cord

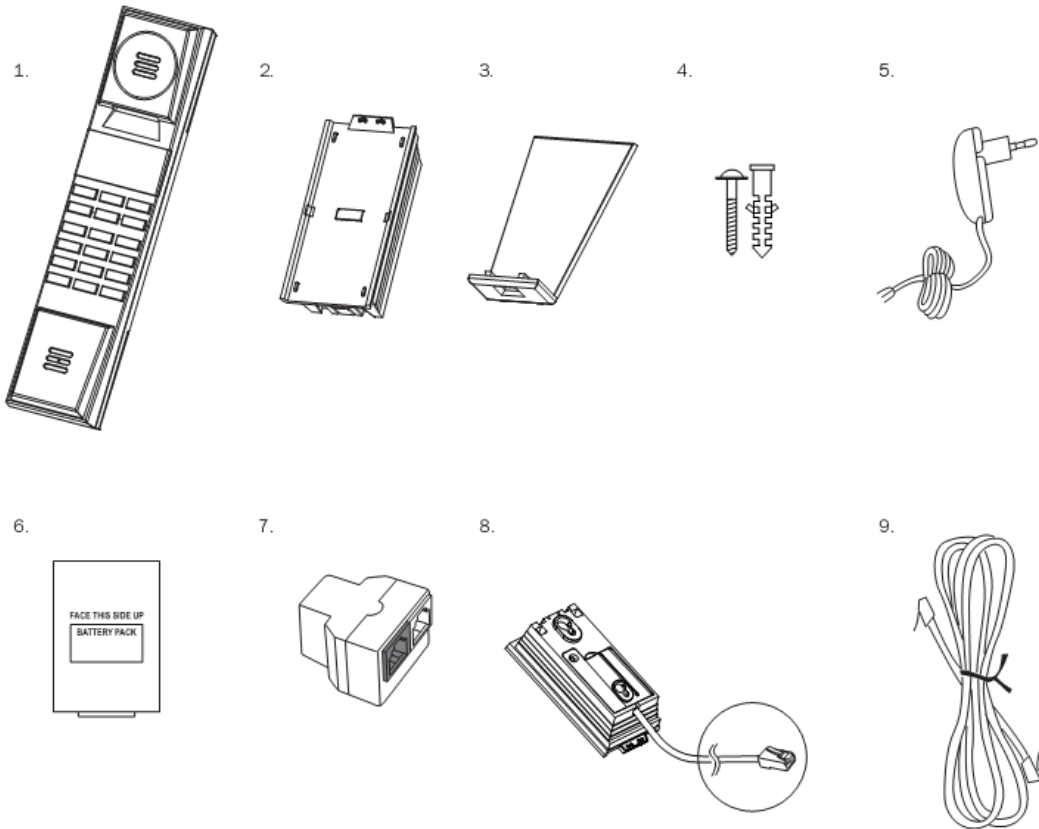

Illustration Diagram

Handset

1. Earpiece
2. Rear Speaker
3. LCD screen
4. Function Keys
5. Dial number Keys
6. Microphone
7. Changeable Speaker-cover and Battery Compartment (user handset)
8. Handset charging contact

Base

9. Base charge contacts
10. Charge indicator
11. Page Key

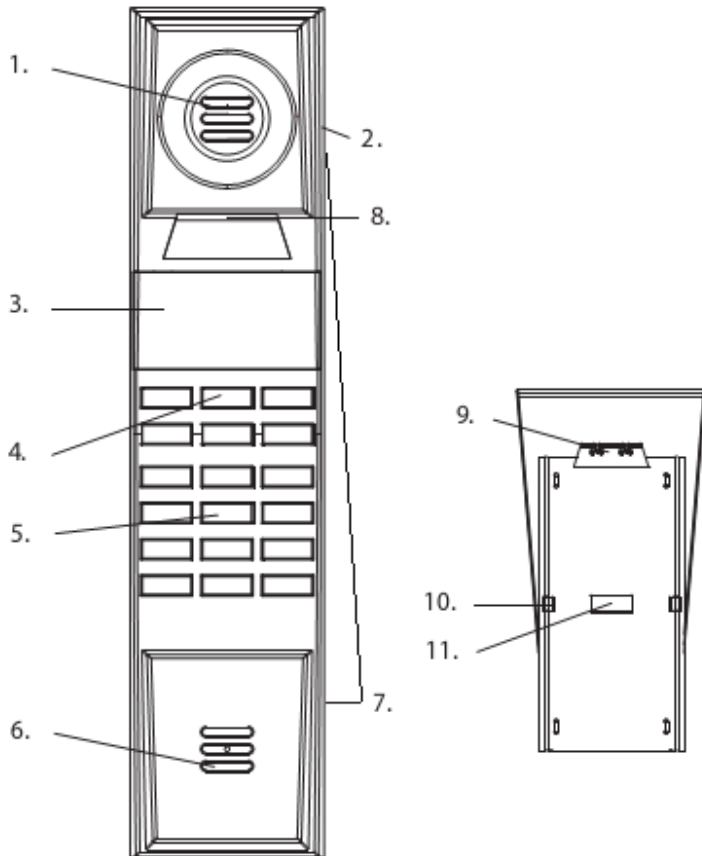

Main Feature List

- 12 hours talk time
- 7 days standby time
- Indoor range 50m
- Outdoor range 300m
- Low radiation
- LCD type, 14 digit x 3 line + icons
- Flash selectable 80 ~ 800mS
- Caller ID Type 1 & 2 and DTMF
- Call log List
- Hands-free
- Speaker and ringer volume
- 100 phonebook memory locations
- HS intercom
- 3-Party conference
- Call Transfer between HS
- Alarm call and date reminder
- 8 midi/polyphonic ringtones
- Room monitor
- Equalizer
- Li-ion Battery

A.	INSTALLATION AND START-UP.....	7
B.	DISPLAY SYMBOLS AND THEIR INDICATION	12
C.	BUTTONS AND THEIR FUNCTIONS.....	13
D.	PREPARATION BEFORE USE.....	16
E.	NORMAL OPERATION	23
F.	PHONE BOOK.....	26
G.	CALLER IDENTIFICATION MEMORY (CALLER ID)	29
H.	PERSONALIZING YOUR PHONE	31
I.	ADVANCED OPERATION	33
J.	REVERTING TO FACTORY DEFAULT SETTING.....	37
K.	MAINTENANCE	38
L.	TROUBLESHOOTING	39
M.	SAFETY PRECAUTIONS	41
N.	WARRANTY AND SERVICE.....	42
O.	FCC COMPLIANCE	43

Congratulations with your new JACOB JENSEN™ Telephone.

The Telephone 10 is designed in Denmark by Jacob Jensen, whose products have gained international recognition for their original, simple and classic design. It is a state of art device created with consideration of form and function. The Telephone 10 is designed for both desktop and wall mounting and a wall mount bracket is included in the gift box.

The Telephone 10 is powered with latest digital technology – DECT system (Digitally Enhanced Cordless Telecommunication). It brings you digital sound, penetrating range and user-friendly menu-driven functions. According to the DECT system standard (GAP compatible), 6 different handsets can be registered to a single base unit to perform function of a mini-PABX system which offers you functions of intercom and call transfer between handsets. In addition, its built-in Caller ID decoder, Phone Book, Redial List and Caller ID memory provide you great convenience to manage your phone calls.

The Telephone 10 is equipped with a low radiation feature in both the base and the handset. It works intelligent by detecting and adjusting the strength of the radio frequency (RF) signal depending on the distance between the handset and the base as well as the number of handsets attached. This is done automatically where the system always adjusts the RF-signal to the minimum radiation according to the working conditions.

This DECT telephone can only work under constant main power supply. It is advisable to connect another corded phone (which works without main power supply) to your telephone system for emergency calls in case of power failure.

A. INSTALLATION AND START-UP

The cordless phone system can only work under constant power supply to the base station. It is advisable that another corded phone (works without main power supply) is connected to your phone system for emergency call purpose in case of power failure.

Caution

- Use only the Ktec Model KSLFB0750035W1US power adaptor unit that came with unit. Using other power adaptors may damage the unit and invalidate your warranty.
- Plug the adaptor to the socket-outlet that near the equipment and shall be easily accessible.

1. Unscrew the back cover from the base station.

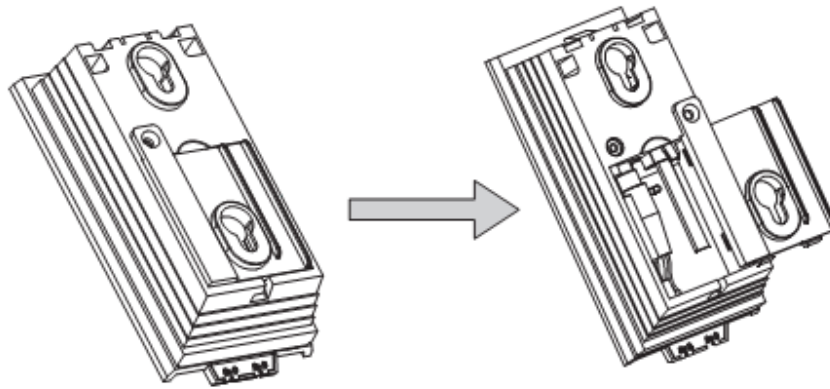

2. Connect the combo cord to the RJ45 jack of the combo jack.

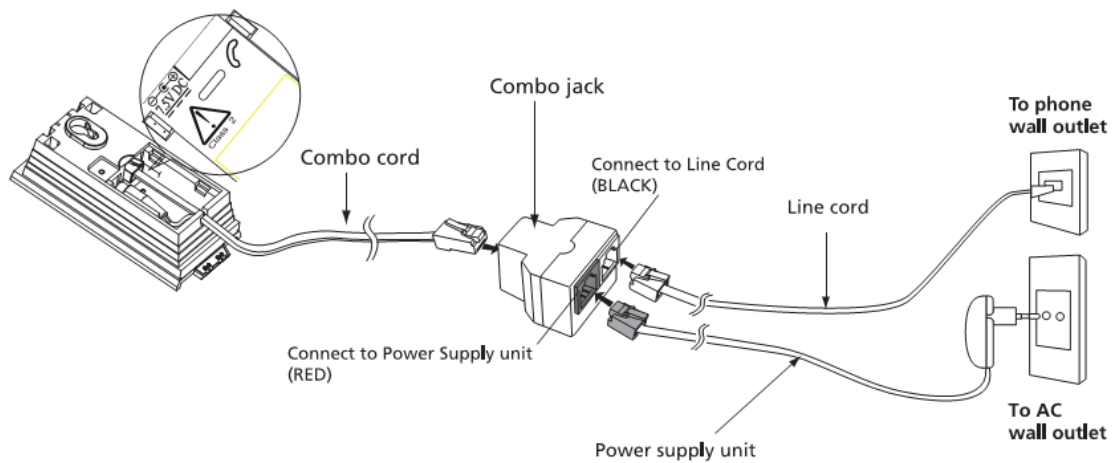

3. Plug the power supply into the main wall outlet and connect the other end to the RED jack of the combo jack
4. Connect one end of the telephone line cord to the BLACK jack of the combo jack; connect the other end of the telephone line cord to the country telephone plug adaptor (optional).
5. Connect the country telephone plug adaptor to the wall outlet for telephone.

A.1 Assembling the table stand

Slide the canals of the table stand into the tracks of the back side on the base station. The table stand is mounted when you hear a click.

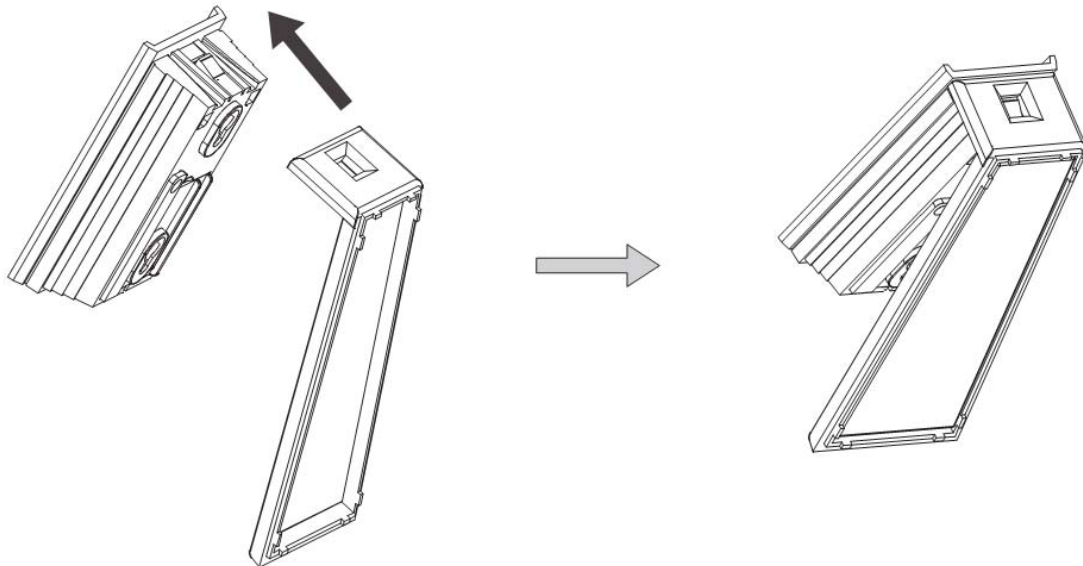

A.2 Wall Mount

If you desire wall mount, please follow the following procedures:

1. Push the button inside the square hole at the bottom of the base station, using a pen or a finger, and pull the bracket away from the base station at the same time.

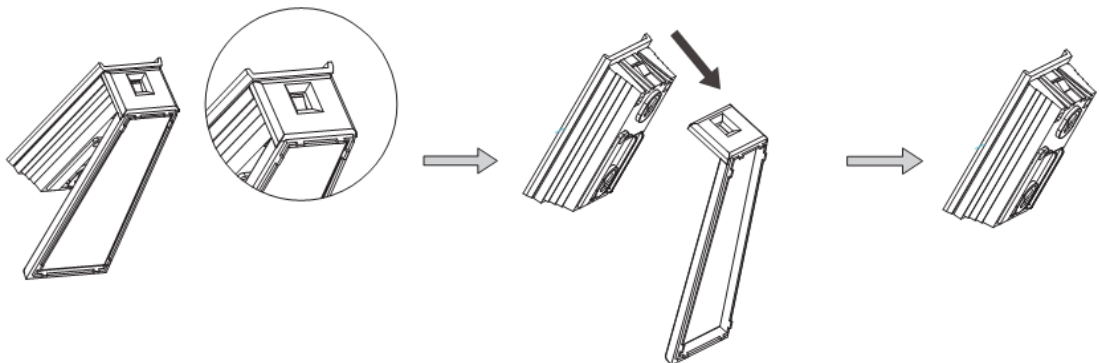

2. Pull the combo cord downwards through the groove in order to let it out at the bottom and connect it to the combo jack.

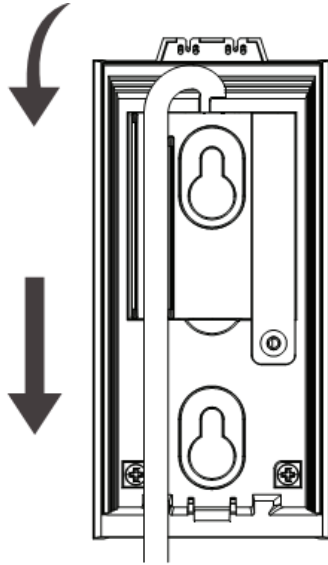

3. Mount the base station by the enclosed screws and plugs for 6mm drill.

A.3 Fixing battery

1. On the handset, firmly slide and remove the handset back cover, install the rechargeable battery into the the battery compartment. Slide back the handset back cover. The LCD screen will light up as soon as battery installed.

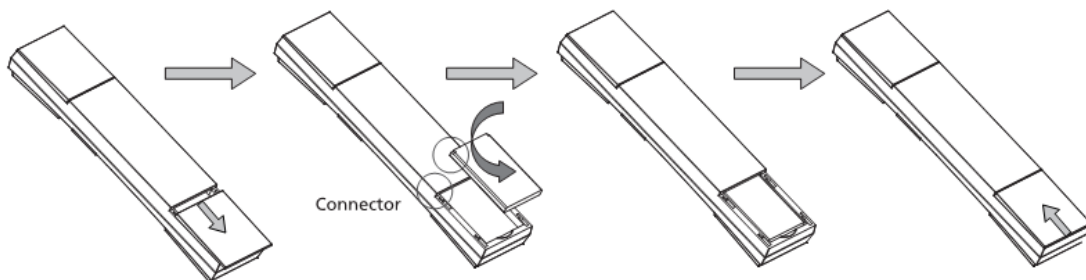

Caution

- Risk of explosion if battery is replaced by an incorrect type. Use only the RTX battery model 60020437 , 3.7V 650mAh Li-ion rechargeable battery pack.
 - Dispose of used batteries according to the instructions.
 - You must install the handset batteries before using the cordless handset.
 - Li-ion batteries must be disposed of in accordance with the applicable waste disposal regulations.
 - Do not dispose of the battery(ies) in fire. They may explode. Check with local codes for possible special disposal instructions.
 - Keep batteries out of the reach of children
2. Put the handset into the base unit, according to the picture shown below. Make sure that the LED charge indicator on the base unit lights up to show charging is in progress.

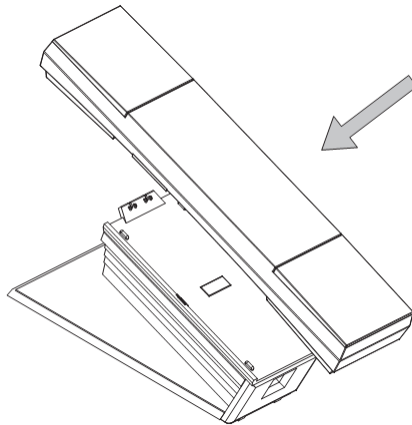



Important Notice

- To obtain best battery performance, keep the handset being charged for 6 hours after first time installation.
- When handset is removed from the base, the LED in the base will stay on for approximately 5 seconds before it will fade off.
- Remove battery form this product if storing over 30 days.

A.4 Setting language

Depending on product package (refer to information on packaging), additional handsets with standalone charging units may be included in package. Simply connect batteries of the additional handset as described above, and connect power adapter of standalone charging unit to the wall outlet. Then you may put additional handset onto standalone charging unit for initial 6 hours recommended charging.

After the initial charging of 6 hours you can start using your telephone. If you would like to choose another language than the pre-set English do as follows:

Press  and press  3 times to select **Display** → press  → press  twice to select **Select Lang**. Press  → press  to select your desired language: **English, Deutch, Francais, Italiano, Nederlands, Espanol, Dansk, Svenska, Türkse, Norsk** and press 

A.5 Replacement of Batteries

Depending on your usage, it is recommended to change rechargeable batteries every year to achieve best performance.

To replace batteries, follow instructions below:-

1. Prepare one rechargeable batteries, 3.7V 650mAH Li-ion battery, part number 60020437.
2. Gently remove the handset back cover, remove the old battery.
3. Observe polarity marks inside the battery compartment, and insert the rechargeable battery. It is not possible to connect the battery with wrong polarity.
4. Replace the handset back gently; making sure the orientation of battery compartment cover is correct.

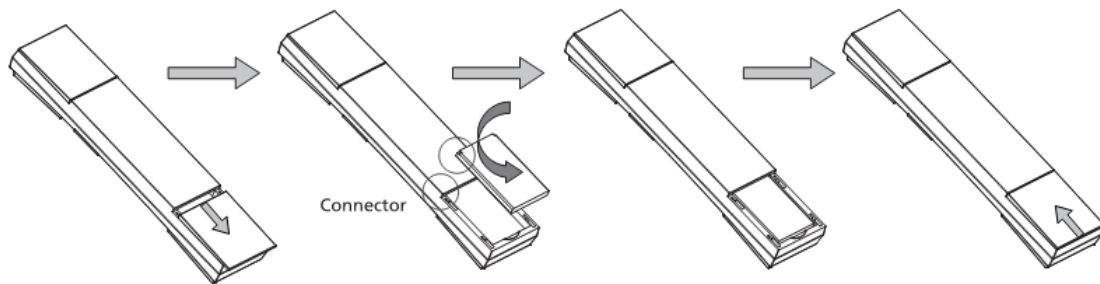

A.6 Operation

To lift off the handset, gently press on the upper part of the handset with your index finger and the handset falls into your hand.

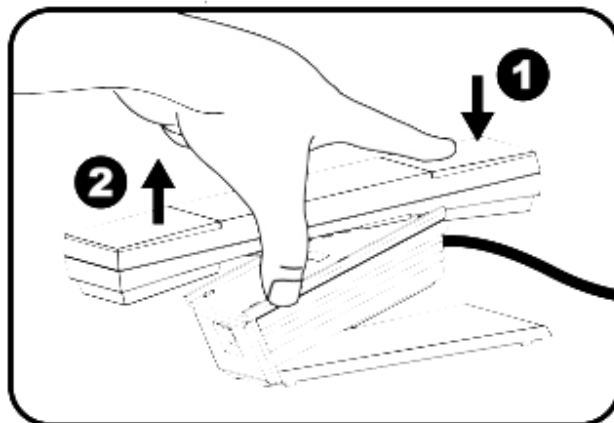

B. DISPLAY SYMBOLS AND THEIR INDICATION



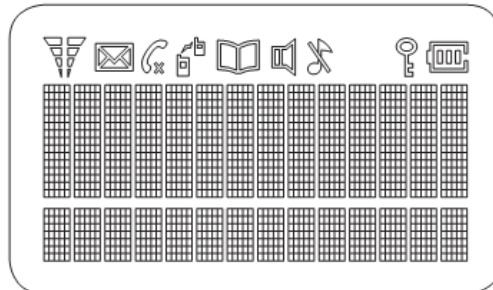



In standby/Idle mode:





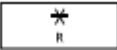







Symbol	Indication
01/20	It shows the current date in month/date format
14:05	It shows the current time in 24 hours format
	Always displays when your handset is on, shows the battery status
	Battery fully charged
	Battery half charged
	Empty and you hear a warning tone – the battery capacity is low and needs charging. Remains steady when the line is in use.
	Displayed when the ringer volume is set to OFF
	Phone book review mode. It shows when Phone Book records are being viewed.
	It shows the phone is in on-hook mode. Flashes while connecting and receiving calls
	It shows the phone's microphone is muted
	Message Waiting Indicator. Depending on your operator's service, this symbol turns on when voice message is left in your message box registered with telephone operator.
	Hand-free speaker phone is on
	Keypad lock. It shows when keypad is locked.
	Intercom/internal call. It shows when intercom is made
	A constant receiving power symbol shows good reception and transmission power of radio signal. The bars will be the receiving signal and will always at a high level when the handset is close to the base unit. The bars will be at a low level as the receiving power is weaker when the handset is far away from the base.

C. BUTTONS AND THEIR FUNCTIONS

Before going through the following keypad functions, it is a good idea to understand multiple functions may be assigned to a single button in order to reduce buttons cluster. To some buttons, short and long pushes on one button give you different functions in different mode. Pay attention to the following description regarding long and short push. Short push means push and release immediately. Long push means push and hold for approximately 2 seconds.

Button	In standby mode	In conversation mode	In programming / viewing mode
On Handset unit			
	Push this button to access the menus.		In programming mode, press this button to confirm a setting.
	To enter digit 0-9	To enter digit 0-9	To enter digit 0-9 or to enter alphabet characters.
	This button functions as  when a short push is given.	To enter 	
	To enter This button switches the handset keypad lock on and off after a long push.	To enter #	

Button	In standby mode	In conversation mode	In programming / viewing mode
	<p>In standby mode, a short push to this button will bring you redial function. Last 10 called numbers will be kept in the redial memory. Numbers stored in the redial list can be up to 24 digits long.</p> <p>Use the key  and  key to select desired number. Press the  button to dial the displayed number.</p>	<p>In conversation mode, this button functions as "volume up" for both the earpiece or the speaker phone volume.</p>	<p>In programming & memory review mode, this button functions as "scroll up" when a short push is given. Use to scroll through the phonebook, menu, redial list, or caller ID log.</p>
	<p>In standby mode, a short push on this button will show you the phonebook list. The display shows the first alphabetical entry in the phonebook.</p> <p>Use the  key and  key to scroll through the entries and display the entry you want. Or search alphabetically for the entry by entering the first letter of the name you want using the keypad.</p>	<p>In conversation mode, this button functions as "volume down" for both the earpiece or the speaker phone volume.</p>	<p>In programming & memory review mode, this button functions as "scroll down" when a short push is given. Use to scroll through the phonebook, menu, redial list, or caller ID log.</p>

Button	In standby mode	In conversation mode	In programming / viewing mode
	<p>Press to end a call. Press to exit the menu mode and return to standby.</p> <p>Press and hold to turn handset on or off.</p> <p>When the handset is turned off, you cannot make or receive calls on that handset.</p> <p>To turn the handset on again, press and hold this button once again or simply place the handset in the charger.</p>		
	<p>While the phone rings, press and hold this button for three seconds to turn off the ringer temporarily.</p>		<p>In programming mode, this button functions as Cancel or Delete. Press it to delete incorrect digits or letters. Press this to go back to previous menu.</p>
	<p>Press to make and receive calls.</p>		
On Base unit			
<p>PAGE Press and hold for 5 sec to enable registration mode</p>	<p>Push this button to make a page ring at the handset.</p>		

D. PREPARATION BEFORE USE



Attention

Your DECT phone is protected by PINs (personal identification numbers). Never change the PINs of your handset nor base unit unless you are familiar with electronics products and you have a real need to protect your phone by special PINs. A forgotten PIN could stop operation of your DECT phone and may result in expensive technical support services.

Please refer to the ADVANCED OPERATION SECTION FOR DETAILS.

D.1 THE OK/MENU BUTTON

This DECT phone is built with a user-friendly MENU function. All essential functions of this phone can be programmed via the MENU button  by a question & answer (Q&A) approach.

By pushing the  button on the handset, it leads you to browse through the following function menus in a circular manner. You may push  to browse upward and  to browse downward.

Call log list > Internal call> Audio setting >Display > Auto Talk > Time & Alarm > Add. Settings > Base settings > Room Monitor >



Throughout the remaining part of this Instruction For Users, a quick Key Map will lead you to different programming areas where you will be asked to make your selections.

D.2 SETTING LANGUAGE

English is factory-programmed display language. To change the language setting:-

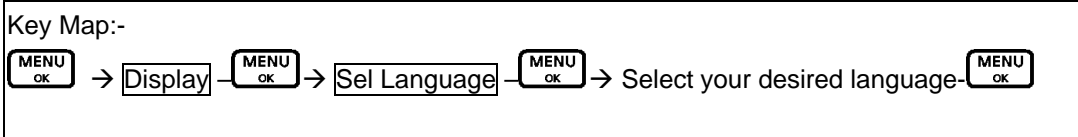
Display language on handset:-



1. Use the  /  buttons to browse through available language
2. When desired language is shown, push  again to confirm.

D.3 SETTING DATE/TIME



Depending on country and telephone operation, usually every caller ID memory will be stored with its incoming date and time information. It is not necessary to set date/time for use of this DECT

phone in country with FSK caller ID system as date/time information will be received automatically from caller ID signal.

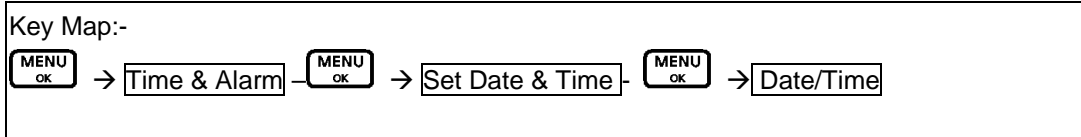

For use in country with DTMF caller ID system (or countries with FSK system where date/time is not sent from telephone operator), go through the following procedures to set date/time information:-



24 Hours mode (For EU version)

1. Use the numeric button on the handset to enter DATE information (DD/MM/YY format), e.g. 030605 for 3rd June 2005, push  again to enter TIME information (24:00 hour format). When finish, push  again to confirm. Press the  button to return to standby mode.

12 Hours AM/PM mode (for US version)

1. Use the numeric button on the handset to enter DATE information (MM/DD/YY format), e.g. 060305 for 3rd June 2005, push  again to enter TIME information (12:00 hour format). Use * key so select between AM/PM. When finish, push  again to confirm. Press the  button to return to standby mode.

D.4 KEYPAD LOCK

You may lock the keypad of your handset to avoid accidental operation. To lock the keypad of your handset, give a long push on the  button on your handset.

When your keypad is locked, symbol of keylock will show on the screen. When the keypad lock is on, you can still receive calls by pressing the  button.

To unlock your keypad, repeat the above procedure and keypad will be unlocked.

D.5 AUTOMATIC CALL PICK-UP

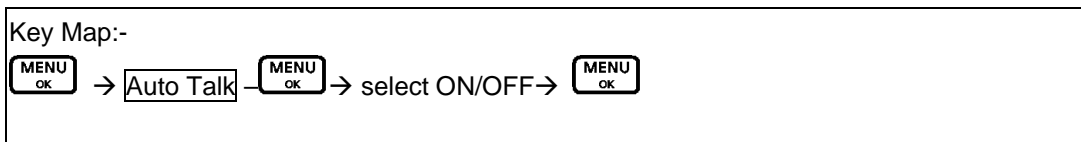



Incoming call may be taken automatically when handset is lifted from the base unit. This is on condition that Off Hook mode is set to ON. If the automatic call pick-up is off, you have to press the

 button to answer a call, even if a handset is on the base or charger. The default setting is “On”.









Press the  button to return to standby mode.

D.6 SOUND ENHANCER

Key Map:-

 →  → Sound Enhancer → 







You can adjust the Audio Tone of the earpiece. Your phone gives you four audio tone options: Normal, Bass, Alto, or Treble.

1. Press  button or during a call, press the  button to access the main menu.
2. Press  /  button to select “SoundEnhancer”. Press  button.
3. Press  /  button to select one from “Normal, Bass, Alto, or Treble. Press  button to confirm.

D.7 MUTE/UNMUTE

Key Map:-

 →  → Mute/Unmute → 







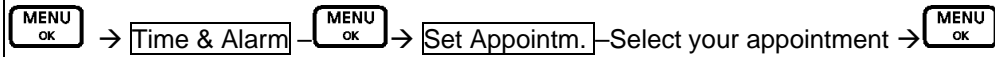







1. Press  button or during a call, press the  button to access the main menu.
2. Press  /  button to select “Mute”. Press  button.
3. The mute icon  will show on the screen.
4. To unmute the phone, follow the above procedure and select the “unmute”. Press  button. The mute icon will disappear from the screen.

D.8 APPOINTMENT

Key Map:-



The Date and Time must be set before you can access the Calendar menu option. To set Date and Time, see the section of setting Date and Time. Your phone allows you to set 5 personalized date and time appointments.







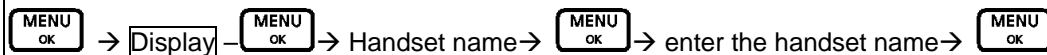

1. Press the  button to access the main menu.
2. Press  /  button to select "Time & Alarm". Press  button.
3. Press  /  button to select "Set Appointm.". Press  button.
4. Press  /  button to select one from "Appointment 1" to "Appointment 5". Press  button.
5. Press  /  button to select "On". Press  button.
6. Enter date and time for the appointment. Refer to the section of setting date and time. Press  button.
7. Enter the appointment name using the keypad(up to 13 characters). Press  button.

D.9 HANDSET NAME

Key Map:-



You can change the name your phone displays on the screen. If you have more than one handset, you can use the name to identify your handset.

1. Press the  button to access the main menu.
2. Press  /  button to select "Display". Press  button.
3. Press  /  button to select "Handset Name". Press  button.
4. "Handset Name" appears. Enter the name using the number keypad. Press  button.
5. Press the  button to exit and return to standby mode.

D.10 HANDSET NAME

You can select the type of information displayed during a call – the time or the call or the caller's number (if available). The default setting is Time.

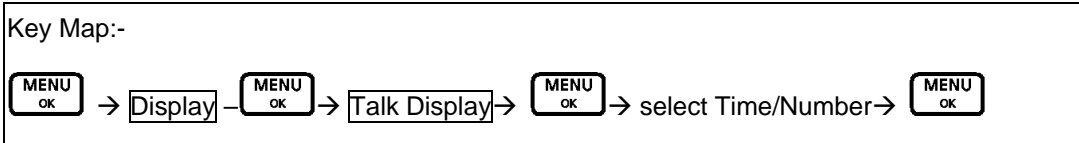

1. Press the button to access the main menu.
2. Press / button to select “Display”. Press button.
3. Press / button to select “Talk display” . Press button.
4. Press / button to select “Time” or “Number”. Press button.
5. Press the button to exit and return to standby mode.

D.11 TONES

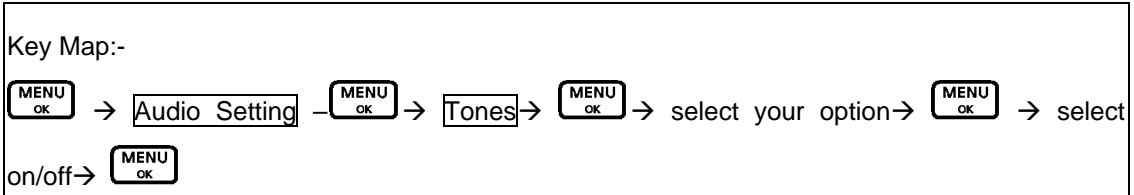

You can switch on or off the tones for key touch, confirmation, call waiting, and out-of-range alarm. For example, when the key tone is set to ON, you will hear a tone each time you press a keypad button.

1. Press the button to access the main menu.
2. Press / button to select “Audio Settings”. Press button.
3. Press / button to select “Tones” . Press button.
4. Press / button to select the option (i.e. Warning, Call waiting, Range Alarm) and to confirm.
5. Press / button to display either “On” or “Off” and press button to confirm.
For key tone, select from pattern 1-3 or off and press button.
6. Press the button to exit and return to standby mode.

D.12 DIAL MODE

You can set your phone to use either Tone or Pulse dialing. The pre-set setting is Tone dialing, where you will hear a tone beep each time you dial a number. Most modern exchanges and switchboards use Tone dialing, so you should not need to change this setting. Only change it if your switchboard uses Pulse dialing or if you cannot make a call using Tone dialing.

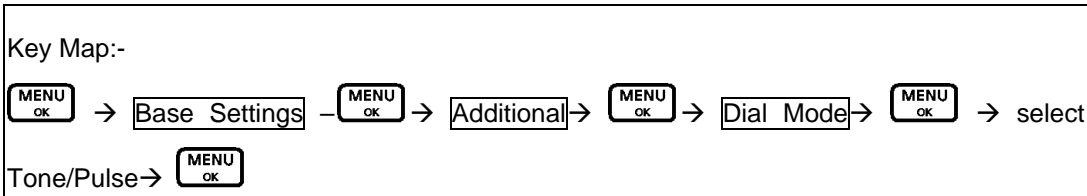

1. Press the button to access the main menu.
2. Press / button to select “Base Settings”. Press button.
3. Press / button to select “Additional”. Press button.
4. Press / button to select “Dial Mode”. Press button. The current setting is displayed.
5. Press / button to select either “Tone” or “Pulse”. Press button to confirm.
6. Press the button to exit and return to standby mode.

Tone dialing Switch-Over

If you have set your phone to use Pulse dialing, you can switch temporarily to Tone dialing for the duration of a call:

1. Press button.
2. Enter the number you want. Press and hold “D” will be displayed. Any digits entered after the “D” will be dialed using tone dialing.

D.13 PREFIX DIALING

If you need to add a prefix to the number for a long distance call, or if you need to add your saved area code to the number, do the following:

Key Map:-

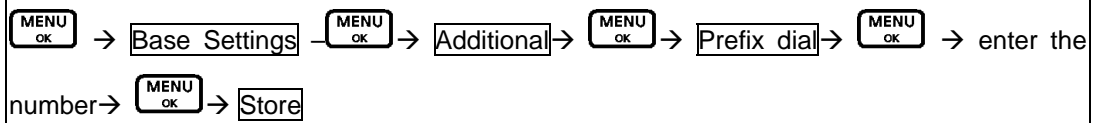

1. Press the button to access the main menu.
2. Press / button to select "Base Settings". Press button.
3. Press / button to select "Additional" . Press button.
4. Press / button to select "Prefix dial" .Press button. The current setting is displayed.
5. Enter the number using the number keypad or press the button to clear. Press button to confirm.
6. Press the button to exit and return to standby mode.

D.14 CALL BARRING

When switched on, Call Barring prevents calls from being made to a specific number, area code or international code.

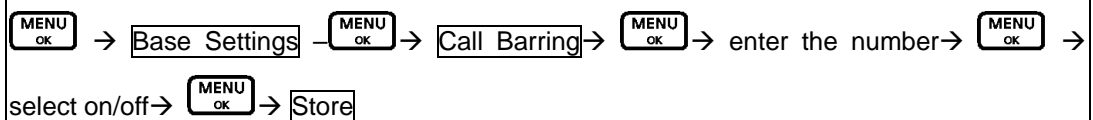

Key Map:-





1. Press the button to access the main menu.
2. Press / button to select "Base Settings". Press button.
3. Press / button to select "Call Barring" . Press button.
4. Enter the number using the number keypad or to clear. Press button to confirm.
5. Press / button to select "On" or "Off". Press button to confirm.
6. Press the button to exit and return to standby mode.

E. NORMAL OPERATION

E.1 TO MAKE A NEW CALL

1. You can only make call with your handset. You cannot make call from your base unit.
2. On the handset, press the  button and the . When you hear the dial tone, enter the telephone number to be called. Entered number will be dialed automatically. After a short delay, the call timer will start timing the call.
4. Press the  button to exit and return to standby mode.

E.2 TO RECEIVE A CALL

1. You may receive calls through the handset only. When you receive a call, the handset(s) will ring as long as the handset ring volume is not set to off. The telephone icon on the handset screen will flash.
2. If you have subscribed to caller ID service with your telephone operator, caller's number will show on the screen while the handset is ringing. If the caller's number is stored already in the Phone Book of your handset (refer to the Phone Book section), the matched name will be displayed on the handset display screen when the phone receives a call.
3. Simply push the  button to answer the call or simply lift the handset from the base. (providing the automatic call pick-up is set to on, see the section of "Automatic call pick-up section). After a short delay, the call timer will start timing the call.
4. To end a call, push  button on the handset to disconnect the line.

E.3 TO MAKE & RECEIVE INTERNAL CALLS (INTERCOM)

In a standard package, your phone comes with a handset and a base unit. Depending on the package you have purchased (please consult product packaging), separate handset may be included for extended usage.

Internal communication (INTERCOM) can be made between handsets – like intercom, call transfer & conference conversation.









Your handset is given an individual extension number. This individual extension number will be used when making intercom, call transfer & conference conversation.

Extension number for handset(s) starts from 1 to 6.

In a standard package, your phone comes with one handset and one base unit.

E.4 TO MAKE AN INTERNAL CALL FROM HANDSET TO ANOTHER HANDSET

You may make intercom from your handset to a specific handset extension.

1. On the handset, press the  button and select the "Internal call". The  icon is displayed and you will hear the internal call dialing tone.
2. Use the  or the  button to select the name, number, or the handset you want to call. Press  button or  button. The handset will ring.
3. When the called handset answers, press the  button or place the handset back on the base to end the call.
4. To answer an intercom ring, simply push the  button on the called extension unit.

E.5 TO PAGE ALL HANDSETS FROM THE BASE

You can only page all registered handsets at the same time by pushing  button on the base unit.





If you have misplaced your handset, you may also use the  function from the base unit to make a page ring at the handset.

E.6 CALL TRANSFER & CONFERENCE CONVERSATION



Transferring a call

You can transfer an external caller from your handset to another handset

During an external call:

1. Press  button and select the "internal call". The external caller is put "on hold"
2. Press  or the  button to select name, number or the handset you want to transfer the call to and press  or the  button. The called handset will ring.









Note: If you do not select another handset to transfer the call to within 60 seconds, your caller will automatically be taken off of hold allowing you to continue your conversation.

3. When the called handset answers, press the  button to transfer the call. If the called handset does not answer, press the  button to return to the external caller.

Conference call

You can hold a 3 way conversation (conference call) between your handset, an external caller and another internal handset user.

During an external call:

1. Press the  button and select “internal call. The external caller is put “on hold”
2. Press  or the  button to select name, number or the handset you want to have a conference call with and press  or the  button. The called handset will ring.
3. When the called handset answers, press  scroll down to **FLASH** and press  to start your conference call.
4. Any handset can press  button at any time to leave the conference call.

F. PHONE BOOK

There are 100 phone book memory banks built inside this DECT phone (13 characters & 24 digits). You may store frequently used number into these memory banks.

If more than one handset comes with your product package (refer to information on package), phone book memories are independent among handsets. Phone book memory will not be automatically transferred from one handset to the others.

F.1 TO MAKE A NEW ENTRY

Key Map:-

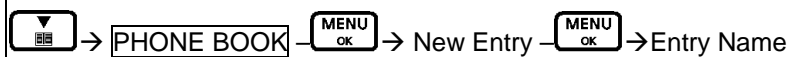

1. Use the alphanumeric buttons (2 to 9) to enter a name for the record in the same manner as you manage alphabet input from your mobile phone. Push [MENU OK] again to confirm. Press [CLEAR ←] to delete an incorrect letter.



If you enter a letter and the next letter is on the same button, press the [↓ ☐] button to move the cursor to the right or wait 3 seconds for the cursor to move. To switch between upper and lower case, press [* R] button

2. Use the numeric buttons to enter phone number (timed pause can be inserted inside telephone number if connection after PABX), push [MENU OK] again to save the record. Press [CLEAR ←] to delete an incorrect letter.
3. Press the [▲ REDIAL] button to select a tone type and press [MENU OK] to confirm.
4. Press the [▲ REDIAL] button to select [save] or [go back] and press [MENU OK] to confirm.
5. The phonebook entry is now stored. Press the [☐] button to return to standby model.







F.2 TO MAKE A NEW ENTRY FROM CALLER ID MEMORY AND REDIAL LIST

You may copy a number stored in Caller ID memory and Redial list to Phone Book. (Consult sections of Caller ID and Last Number Redial for more details)

1. When a desired number is shown while you are reviewing caller ID memory or redial list, push



 button once. **Store to Phbk** is displayed. Press . Enter a name using the keypad and press  button to confirm.

If you enter a name that is already stored in the phonebook, you will be prompted to enter another name.

2. The number is displayed. To confirm and save the entry to the phonebook, press  to confirm.
3. If necessary, you can edit the number using the  button to delete any incorrect digits and enter new ones using the keypad.
4. Press  /  button to select a distinctive ring.
5. When finished, push  button again to complete.
6. Press the  button to exit and return to standby mode.

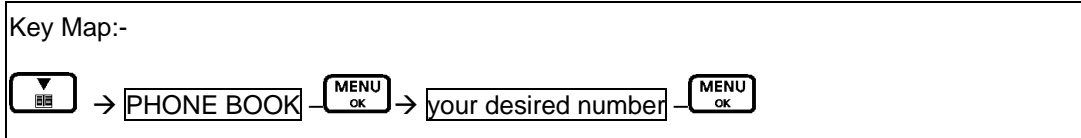



F.3 TO MAKE A CALL FROM PHONE BOOK MEMORY

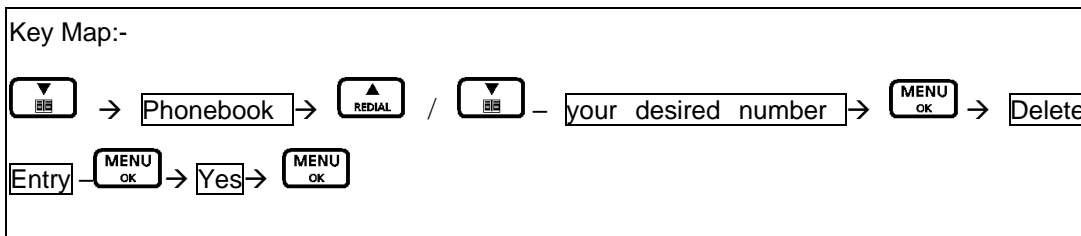

1. Use the alphanumeric keypad to enter first letter of a desired name inside the phone book.
First record starting with the entered letter will be shown on the screen.
2. Use  /  buttons to start browsing until desired name is shown.
3. Push  button to make the call.

F.4 TO DELETE PHONE BOOK MEMORY









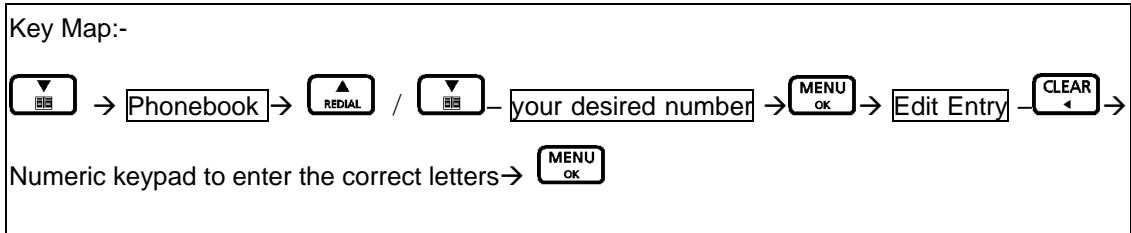

1. Use the  /  buttons to scroll until desired name is shown on the screen.
2. Push  to confirm or press  button to go back to the menu screen without deleting.

You will be asked to confirm permanent deletion of phone book record. To confirm, push  again and the selected phone book record is deleted and a long beep will be heard.

F.5 TO CHANGE PHONE BOOK MEMORY



1. Use the  /  buttons to scroll until desired name is shown on the screen.
2. Push  to confirm.
3. You may use  button to delete letters of the name entry and make correction.
4. When name entry is finished, push . You may use  button to delete numbers of the phone number entry and make correction.
5. Push  again to save the record.
6. Select a tone type and press .

G. CALLER IDENTIFICATION MEMORY (CALLER ID)

If caller ID service is available from your service operator and you have subscribed to this service, telephone number of the caller will be shown on the screens of handset when there is an incoming call. In FSK caller ID system, name of the caller and date time stamp will also be displayed and stored if they are available. Only the first 13 letters of the caller's name are displayed.

This DECT phone stores last 30 caller ID records into caller ID memory. It can store up to 24 digits long and names up to 13 characters long. Oldest record will be replaced by newest record.





If the caller has withheld their listing, "Unavailable" or "Private" will be displayed or, if the number is unavailable the display will show "Unavailable". You will not be able to dial back an entry with one of these messages.

Call waiting tone



This model has a special call waiting tone in addition to the one you typically hear from your local service provider. This tone will be heard after the standard tone when you receive a call waiting notification. This tone is provided as an extra feature and will have to be turned on in order to activate as the default setting is set of "off". To turn this feature on, go to the menu, select audio setting, tones, and call waiting – then set the feature to "on"

G.1 TO REVIEW CALLER ID RECORDS

Caller ID records can be reviewed at only one handset at a time because the records is only store in base unit.

1. To review Caller ID records in handset, press the  button and select the "Call log list".
Use  /  button to scroll among records. Or press the  button to exit and return to standby.

G.2 TO MAKE A CALL FROM CALLER ID RECORDS

You may make a call from the caller ID records. Press  button and select the "Call log list". Push  button on the handset to dial the desired caller's number (or name) when reviewing caller ID records.







G.3 TO STORE A NUMBER FROM CALLER ID RECORDS TO PHONE BOOK MEMORY

You may store a number from the caller ID record to a new Phone Book memory. Please refer to PHONE BOOK section for details.

G.4 TO DELETE CALLER ID MEMORY

You may delete either a single or all records in the caller ID memory.

On the handset

1. Press the  button and select the “call log list”. Use the  /  buttons to scroll and select the desired entry you intend to delete. If you want to delete all entries, skip this step.
2. Press  to select “Delete Entry” or “Delete List”.
3. Press  to select “Yes” or “No”. Then press  button to confirm.

G.5 MESSAGE WAITING INDICATOR (MWI)

If Voice Message service is available from your service operator and you have subscribed to this service, the symbol of message waiting  will be shown on the screen when voice message is left in your message box registered with telephone operator.

Depending on your service operator’s service, Message Waiting Indicator should turn off automatically when you have checked your left message in the operator’s server.

H. PERSONALIZING YOUR PHONE

This DECT phone is built with features to offer you personalized settings, such as ringing melody, ringing volume, key click and key lock.

Referring to the description of MENU button in previous section, all those personalized settings can be programmed via Menu Programming mode.

H.1 SETTING RING VOLUME & MELODY

Different ringer volume and melody can be programmed to each handset.

Handset ringer volume

Key Map:-

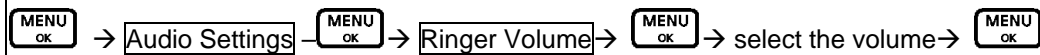





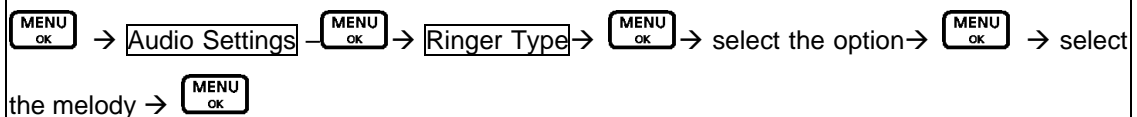

1. To arrive at this menu, push button in standby mode, and use / button to start browsing until “Audio Setting” is shown on the screen. Press .
2. Press / button to select “ringer Volume” and press .
3. Press / button to select the volume you want. (you will hear a sample of each as you scroll through), then press to confirm.
4. Press power off button to exit and return to standby. If you select Volume “Off”, will be displayed.

Handset ringer type

Key Map:-



1. To arrive at this menu, push button in standby mode, and use / button to start browsing until “Audio Setting” is shown on the screen. Press .
2. Press / button to select “ringer Type” and press .

3. Press  /  button to select the “External”, “Internal”, “Paging”, “Alarm”, or “Appointment” and press  to confirm.
4. Press  /  button to select the melody you want. (you will hear a sample of each as you scroll through), then press  to confirm your selection.
5. Press  button to exit and return to standby.

I. ADVANCED OPERATION

Special Attention!!!

Following sections are only for users who are familiar with electronics products.

Failure in following steps correctly may stop your DECT phone from normal operation.

I.1 REGISTERING A NEW HANDSET

When you register a new handset to your base, you will be asked to enter your base PIN code.

To enable registration mode on base unit, press and hold the **PAGE** button for 5 seconds.

Before registering, make sure the new handset is fully charged and that you have the base and handset in front of you. Also, make sure all handsets and the base are in standby.

On the handset you want to register:

Key Map:-

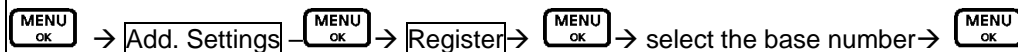

1. Press button to access the main menu.
2. Press / button to select "Add. Settings" and press .
3. Press / button to display "Register" press to confirm.
4. Press / button to select your base number and press to confirm.

If the base already has the maximum number of 6 handsets registered to it you will need to de-register one of the existing handsets before you can register the new handset.

See the section for de-registering handsets.

On the handset:

Enter the base PIN code.

Pre-set base PIN code is 0000.

You will hear a confirmation tone when registration is complete.

When in standby, the new handset number will be displayed.

The handset will automatically be allocated with the next available handset number.









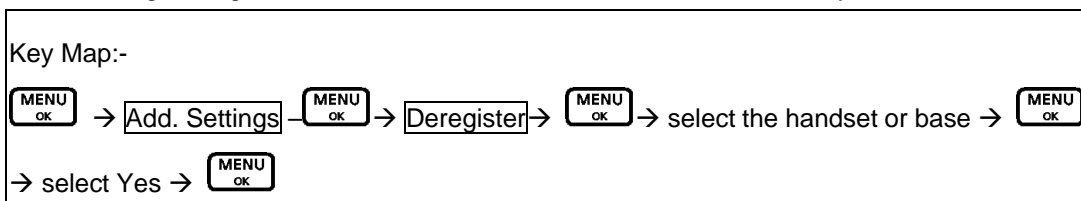





If registration is unsuccessful, the display will show "Not registered" and you will need to follow the registration procedure again.

1.2 DEREGISTERING A HANDSET OR A BASE

If you have more than one handset registered to your base or more than one base registered to your handset(s), you can deregister both the handset from the base or the base from the handset.

Before deregistering, make sure all handsets and the base are in standby.



1. Press  button to access the main menu.
2. Press  /  button to select "Add. Settings" and press .
3. Press  /  button to display "Deregister" press  to confirm.
4. Press  /  button to select "Handset" or "Base" and press  to confirm.
5. Press  /  to select "Yes" and press . If the handset deregisters to the base successfully, you will hear a confirmation tone.
6. Press the  button to exit and return to standby.

1.3 CHANGING THE PIN CODE

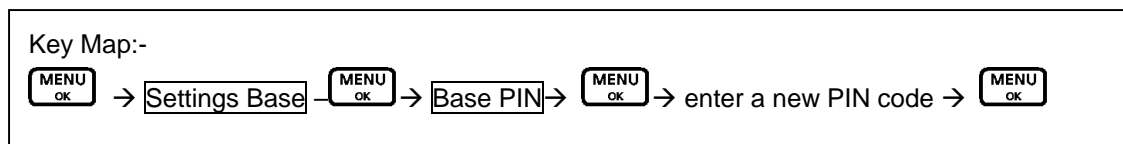

The default Base Pin code is 0000. If you want to change to a new PIN code, follow the above procedures while enter a new 4 digits base PIN code.

1.4 SELECTING A BASE

You can register the handset with up to 4 bases, e.g. one at work and one at home or one upstairs and one in the garage, and switch between them.

Once your handset is registered with other bases, you can either specify the base you want to use or, select “Automatic” for your handset to choose your base with the strongest signal.

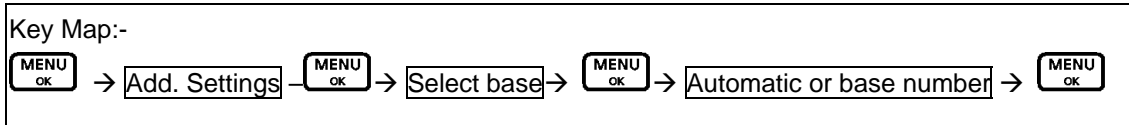

1. Press button to access the main menu.
2. Press / button to select “Add. Settings” and press .
3. Press / button to select “Select Base” press to confirm.
4. Press / button to select “Automatic” or the base number. Press to confirm.

1.5 RESETTING YOUR PHONE

If you reset your phone, both the base and handset will return to their default settings. The time, date, handset, and phonebook will not return to default.

If you have more than one handset registered to your base and you complete the following procedure, only the handset you reset and the base will go back to the default settings.

For the base:

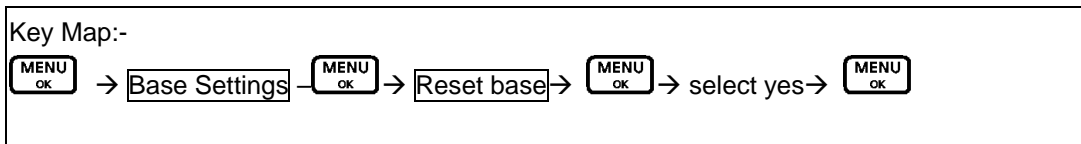









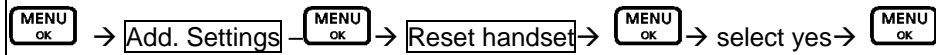

1. Press button to access the main menu
2. Press / button to select “Base Settings” and press .
3. Press / button to display “Reset base” press to confirm.
4. Press / button to select “Yes” and press to confirm.

5. Press the  button to exit and return to standby.

For the handset:

Key Map:-



1. Press  button to access the main menu.
2. Press  /  button to select "Add. Settings" and press .
3. Press  /  button to display "Reset Handset" press  to confirm.
4. Press  /  button to select "Yes" and press  to confirm.
5. The handset will beep.

J. REVERTING TO FACTORY DEFAULT SETTING

You may change all setting in your DECT phone back to factory default setting. The only way to reset the handset or base is to go into the menu and choose “handset reset” or “base reset”. Please refer to the above section of “Resetting your phone”. All programming and settings you have made to the phone will lose automatically. It could be useful if you have programmed too many things at the same time, making conflicts between your settings and affecting normal operation.

Following memory banks will remain unchanged after resetting to factory default:-

- Caller ID memory
- Last Number Redial List
- Base unit and handsets registration



To change all settings back to factory default, go to the section of **Resetting your phone**.

K. MAINTENANCE

1. Do not expose this product to dust, strong sun light, humidity, high temperature, or mechanical shock.
 2. Do not use corrosive or abrasive cleansers on this product. Keep the unit dust free by wiping it with a soft, dry cloth.
 3. Do not disassemble this product, it contains no user-serviceable parts.
 4. In case of a thunderstorm, it is advised to disconnect the power adapter, as product warranty does not cover damage caused by lightning/serge.
 5. Only use adapter and battery pack come with the package.
-
-

L. TROUBLESHOOTING

Q1. My phone does not work!

- A1. Make sure if you have NOT locked your keypad of your handset. When keypad lock is turned on, a  symbol will show on the screen. To remove the keypad lock, push and hold the  button on your handset for approximately 2 seconds and release the button.
- A1. Make sure all connection of adapter and line cord are connected securely to the jacks.
- A1. Make sure you have inserted battery pack into the handset battery compartment, and they are charged with good capacity and inserted with correct polarity.
- A1. If you have connected more than one phone to the same telephone line, make sure all other telephones connected are put on hook. In some telephone systems, when the first phone on the same telephone line is used, all other telephones are electrically disconnected.
- A1. Try to connect another telephone to the telephone socket, if the problem persists, it appears that there is a problem with your telephone line system, consult your network provider.
- A1. If the person of the other end of the conversation does not hear your voice, make sure you have not activated the MUTE function. To test, activate the MUTE function once more and your phone should resume to normal operation.
- A1. Check if the receiving symbol bar “” on the screen is flashing. If it is at a weak level, it indicates your handset is too far away from the base unit and radio signal is too weak. You should get nearer to the base unit and try again.
- A1. If your handset rejects to dial a number, check if that number is barred (Refer to CALL BARRING SECTION).
- A1. In some critical situation, if the handset is without normal battery charging for a prolonged period of time, it may lock itself when battery level becomes too low. Try to disconnect the batteries and put it back on again and put the handset on charger for 16 hours to resume.

Q2. My phone does not ring!

- A2. Check if the ringing volume is set to “off” (details refer to Section of Setting Ring Volume & Melody). Your phone will not ring if the ringing volume is set to “off”. Change the ringing volume to higher setting ranges.
- A2. Make sure if your handset is not switched off.
- A2. Make sure the connection of line cord is connected securely to the jacks.
- A2. Check if you have selected the right base unit via base selection function (if you have

registered more than 1 base unit to your handset.

Q3. The phone book memories do not work as expected!

- A3. Make sure you do not enter telephone number longer than limits mentioned in the phone book section.
- A3. If your phone is connected behind a PABX system, consult your system provider for information of timed pause delay required to make an external call.

Q4. Caller's number does not show on my phone!

- A4. Make sure your phone line is provided with caller ID function from the phone service provider. In most countries, caller ID function must be paid and subscribed separately from normal phone function. For details, please consult phone service provider.
- A4. Callers may suppress their caller's number when making their phone call. Caller's number does not necessary display when a call is received. For details, please consult phone service provider.
- A4. If a call is made from abroad, caller's number cannot be transmitted.

Q5. My handset does not work after I have registered my handset to a base unit from different maker!

- A5. According to DECT standard (GAP compatible), handset can be registered to any DECT system base unit. However, maker specific functions may not be compatible between products. It may happen that only basic function can be operated if handset and base unit from 2 makers are registered together.
- A5. Check if the other base unit is GAP compatible according to DECT standard. Only GAP compatible products can be compatible to each other.

M. SAFETY PRECAUTIONS

When using your telephone equipment, basic safety precautions should always be followed to reduce the risk of fire, electric shock and injury to persons, including the following:

- Do not use this product near water, for example, near a bath tub, wash bowl, kitchen sink or laundry tub, in a wet basement or near a swimming pool. Do not allow the handset to come into contact with liquids or moisture.
- Avoid using a telephone (other than a cordless type) during an electrical storm. There may be a remote risk of electric shock from lightning.
- Do not use the telephone to report a gas leak in the vicinity of the leak.
- Use only the power cord and batteries indicated in this manual. Do not dispose of batteries in a fire. They may explode. Check with local codes for possible special disposal instructions.
- Connect the adaptor to a socket-outlet near the equipment which is easily accessible.
- Do not open the handset, base station or charger. This could expose you to high voltage.
- Do not allow the charging contacts of the charger or the battery to come into contact with extraneous conductive materials.
- Young children should be supervised to ensure that they do not play with the telephone.
- Since the phone works by sending radio signals between the base unit and the handset, wearers of hearing aids may experience interference in the form of a humming noise.
- We advise that this phone should not be used near intensive care medical equipment or by persons with pacemakers.
- Your phone can interfere with electrical equipment such as answering machines, TV, and radio sets if placed too close. It is recommended that you position the base unit a least one meter from such appliances.

N. WARRANTRY AND SERVICE

Warranty

The warranty is the only warranty applicable to this product. All other warranties, express or implied (including all implied warranties of merchantability or fitness for a particular purpose) are hereby disclaimed. No verbal or written information given by Bell Xpress A/S., its agents, or employees shall create a guaranty or in any way increase the scope of this warranty.

Repair or replacement as provided under this warranty is the exclusive remedy of the consumer. Bell Xpress A/S. shall not be liable for incidental or consequential damages resulting from the use of this product or arising out of any breach of any express or implied warranty on this product. Except to the extent prohibited by applicable law, any implied warranty of merchantability or fitness for a particular purpose on this product is limited to the applicable warranty period of 12 months.

Service Centers

Europe

Bell Xpress A/S

Sletvej 50 – 8310 Tranbjerg J.- Denmark

Phone: +45 70 22 60 33

Fax: +45 87 38 02 60

USA

Improvee Corporation

5289 Ne Elam Young Parkway Ste G200

Hillsboro, OR 97124

Email: sales@improvee.com

Toll-Free phone: 888 880 8090

O. FCC COMPLIANCE

Your telephone equipment is approved for connection to the public switched telephone network and is in compliance with parts 15 and 68, FCC Rules and Regulations and the Technical Requirements for Telephone Terminal Equipment published by ACTA.

United States FC Compliance

This equipment has been tested and found to comply with the limits for a Class B digital device, pursuant to Part 15 of the FCC Rules. These limits are designed to provide reasonable protection against harmful interference in a residential installation. This equipment generates uses and can radiate radio frequency energy and, if not installed and used in accordance with the instructions, may cause harmful interference to radio communications. However, there is no guarantee that interference will not occur in a particular installation. If this equipment does cause harmful interference to radio or television reception, which can be determined by turning the equipment off and on, the user is encouraged to try to correct the interference by one or more of the following measures:

- Reorient or relocate the receiving antenna.
- Increase the separation between the equipment and receiver.
- Connect the equipment into an outlet on a circuit different from that to which the receiver is connected.
- Consult the dealer or an experienced radio/TV technician for help.

Any changes or modifications to the equipment not expressly approved by the party responsible for compliance could void the user's authority to operate the equipment.

This device complies with Part 15 of the FCC Rules. Operation is subject to the following two conditions: (1) this device may not cause harmful interference, and (2) this device must accept any interference received, including interference that may cause undesired operation.

Privacy of communications may not be ensured when using this phone.

FC RF Radiation Exposure Statement

This equipment complies with FCC RF radiation exposure limits set forth for an uncontrolled environment. This equipment should be installed and operated with a minimum distance of 20 cm between radiator and your body. This transmitter must not be co-located or operating in conjunction with any other antenna or transmitter.

For hand held operation, this handset has been tested and meets the FCC RF exposure guidelines. Use of other accessories may not ensure compliance with FCC RF exposure guidelines.

DECT 6.0

The telephone is compliant with the DECT 6.0 Standard which operates in the 1.92GHz to 1.93GHz frequency range.

Consumer Information:

- a) This equipment complies with Part 68 of the FCC rules and the requirements adopted by the ACTA. On the **bottom** of this equipment is a label that contains, among other information, a product identifier in the format **US:T7HW400BRTX3072**. If requested, this number must be provided to the telephone company.
- b) An applicable certification jacks Universal Service Order Codes (USOC) for the equipment is provided (i.e., **RJ11C**) in the packaging with each piece of approved terminal equipment.
- c) A plug and jack used to connect this equipment to the premises wiring and telephone network must comply with the applicable FCC Part 68 rules and requirements adopted by the ACTA. A compliant telephone cord and modular plug is provided with this product. It is designed to be connected to a compatible modular jack that is also compliant. See installation instructions for details.
- d) The REN of T80 is 0.0. It is used to determine the number of devices that may be connected to a telephone line. Excessive RENs on a telephone line may result in the devices not ringing in response to an incoming call. In most but not all areas, the sum of RENs should not exceed five (5.0). To be certain of the number of devices that may be connected to a line, as determined by the total RENs, contact the local telephone company.
- e) If this equipment T80 causes harm to the telephone network, the telephone company will notify you in advance that temporary discontinuance of service may be required. But if advance notice isn't practical, the telephone company will notify the customer as soon as possible. Also, you will be advised of your right to file a complaint with the FCC if you believe it is necessary.
- f) The telephone company may make changes in its facilities, equipment, operations or procedures that could affect the operation of the equipment. If this happens the telephone company will provide advance notice in order for you to make necessary modifications to maintain uninterrupted service.
- g) Should you experience trouble with this equipment, please contact Improvee Corporation, 5289 Ne Elam Young Parkway Ste G200, Hillsboro, OR 97124 and phone number 888 880 8090 for repair or warranty information. If the equipment is causing harm to the telephone network, the telephone company may request that you disconnect the equipment until the problem is resolved.
- h) Please follow instructions for repairing if any (e.g. battery replacement section); otherwise do not alternate or repair any parts of device except specified.
- i) Connection to party line service is subject to state tariffs. Contact the state public utility commission, public service commission or corporation commission for information.
- j) **NOTICE:** If your home has specially wired alarm equipment connected to the telephone line, ensure the installation of this DECT Phone does not disable your alarm equipment. If you have questions about what will disable alarm equipment, consult your telephone company or a qualified installer.
- k) This equipment is hearing aid compatible.

This is your guarantee of an authentic JACOB JENSEN™ Telephone.

The individual number below matches the one on your telephone.

Individual No.

.....

Name:

.....

.....

Address:

.....

.....

.....

.....

Bought from:

.....

.....

Date of purchase

.....

Product by: Bell Xpress A/S · Sletvej 50 · 8310 Tranbjerg J · Denmark

www.jacobjensen.com