

# DMR Repeater user manual

Version 1v2



**Radio Activity S.r.l.**

## Index

<b>1</b>	<b>RADIO ACTIVITY DMR REPEATER AND EXPANDIBILITY TO SIMULCAST NETWORK</b>	<b>4</b>
<b>2</b>	<b>PARAMETERS CONFIGURATION AND REMOTE CONTROL</b>	<b>5</b>
<b>3</b>	<b>HARDWARE COMPOSITION OF A BASE STATION</b>	<b>6</b>
3.1	PSU: POWER SUPPLY UNIT MODULE	6
3.2	DSP: DIGITAL SIGNAL PROCESSOR	7
3.3	RECEIVER	8
3.4	TRANSMITTER	9
3.5	I/O AND SERVICES MODULE	10
<b>4</b>	<b>TECHNICAL DATA</b>	<b>11</b>
4.1	REGULATIONS COMPLIANCE	11
4.2	GENERAL CHARACTERISTICS	11
4.3	IP interfacing	12
4.3.1	LAN protocol	12
4.3.2	LAN requirements	12
4.3.3	Ports and connectors	13
4.3.4	Codec VoIP	13
4.4	Radio frequency	14
4.4.1	Transmitter	14
4.4.2	Receiver	15
4.4.3	Frequency bands	17
4.4.4	Commutation band (without duplexer)	17
4.4.5	Branching requirements	17
4.4.5.1	TX to antenna duplex isolation requirements @10W TX RF power	17
4.4.5.2	Suggested RX max input limits on unwanted signals	18
4.5	Other specifications	18
4.5.1	Environmental parameters	19
4.5.2	Power supply	19
4.5.3	Mechanical characteristics	19
4.5.4	Audio balanced interfaces	19
<b>5</b>	<b>EQUIPMENT INSTALLATION AND MAINTENANCE</b>	<b>20</b>
5.1	CONNECTIONS AND PINOUTS	20
5.2	EQUIPMENT START UP, RUNNING AND ALARMS: INDICATOR LAMPS	27
5.2.1	PSU	27
5.2.2	DSP	27

---

5.2.3	RX .....	28
5.2.4	TX.....	28
5.2.5	I/O .....	28
<b>5.3</b>	<b>GENERAL RECOMMENDATIONS AND NOTES .....</b>	<b>29</b>
5.3.1	Improper use .....	29
5.3.2	Thermal dissipation.....	29
5.3.3	Power supply system .....	29
5.3.4	Antenna.....	30
5.3.5	AF interface .....	30
5.3.6	Manual settings.....	30
5.3.7	Self-calibration process.....	31
5.3.8	PPS signal .....	31

## 1 RADIO ACTIVITY DMR REPEATER AND EXPANDIBILITY TO SIMULCAST NETWORK

Radio Activity DMR repeater is designed to be modular from both HW and SW point of view, to maximize its flexibility and minimize costs, physical dimensions, consumptions.

Basic model already has all the characteristics to work as a double standard repeater with all the features of analogical and digital service. It can be equipped with double receiver to counteract fading effects through diversity space reception. It is set to host communication and synchronization embedded devices to make the network expandable to a multi-frequency or iso-frequency multi-site system, with different type of links, operating with different transportation system topology, like microwave, UHF, fiber optics, generic TCP/IP connections.

Privileged communication interface is ethernet standard type, maximally compatible with more diffused technology. This interface supports not only voice and data digital traffic, but also remote control management, which for Radio Activity equipment is very powerful: it is possible to have a complete monitor system of equipment status, it is possible to modify each parameter, to down-load each SW and configuration, launch self-test and calibration functions, to perform specific tests through internal embedded function generators and software analyzers of the station. For analogical voice traffic instead, a 2/4 wire and criteria line interface is available.

Remote control service can be performed through an ethernet connection pre-existing in the site, or through GPRS modem which can be integrated into the station, or through the radio channel and another Radio Activity station.

Fully modular structure allows to best configure the radio equipment, by adding and/or changing the required HW and SW functional blocks, to work as simple repeater, multi-frequency multi-site repeater, iso-frequency multi-site repeater. The basic structure of a base station is made of:

- ∞ PSU module (not isolated 12Vdc from battery);
- ∞ DSP module;
- ∞ RX module;
- ∞ TX module.

Optional modules and accessories are:

- ∞ I/O module with line interface with or without GSM/GPRS and GPS unit;
- ∞ PSU module for isolated power supply sources at 12V, 24V or 48V dc;
- ∞ RX module with diversity receiver;
- ∞ Duplexer, circulator or both;

- ∞ Multi-receiver block for star-shaped network architectures with RF links;
- ∞ Antenna active splitter board.

If a network architecture is needed, Radio Activity base stations can be connected through both a RF or ethernet link.

## 2 PARAMETERS CONFIGURATION AND REMOTE CONTROL

Working parameter of the station are completely programmable through a SW package and a PC connection. The visible (and programmable) parameters set is very wide and extends from radio channel setting to tuning voltage measure of each local oscillator. The software is called **DMR Manager** for single base-stations or **DMR NetControl** for network systems.

Remote diagnostic of radio stations from PC can be performed through the Ethernet interface of the station. This interface is absolutely standard and very diffused, so relatively simple to be remoted. Radio Activity stations can be equipped with an embedded GPRS modem which will provide remote access to the station, if the installation site is covered by this service. Each operation can be remotely performed, exactly the same as in local connection, including FW down-loading, configuration Down-loading and up-loading, station check, parameters changing.

Communication and supervision unit can spontaneously transmit diagnostic messages if defined “self-alarmed” events happen. This is useful to automatically check the stations.

Here following an example of remote control forms:

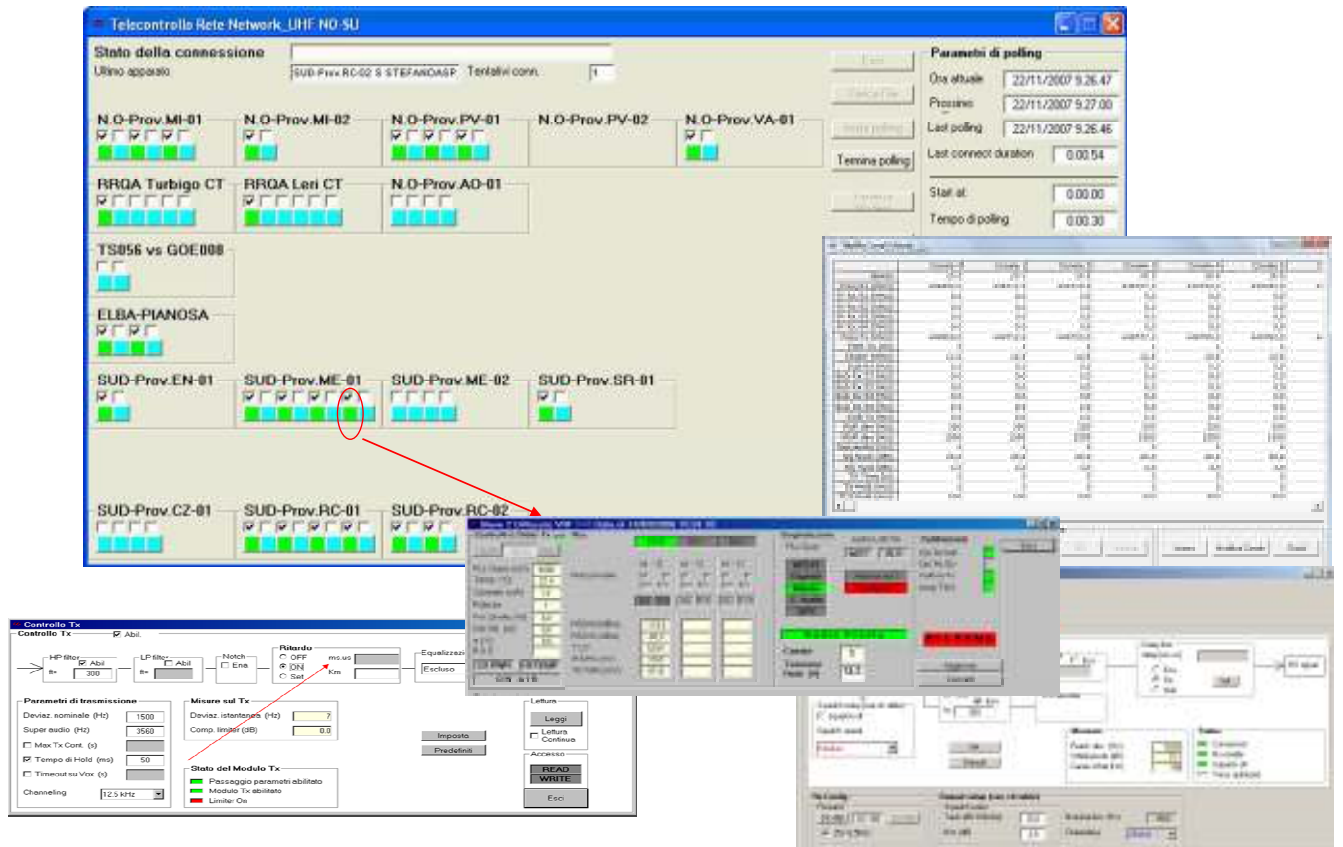

For further details about remote control software, refer to proper documentation (SW user manuals).

### 3 HARDWARE COMPOSITION OF A BASE STATION

#### 3.1 PSU: POWER SUPPLY UNIT MODULE

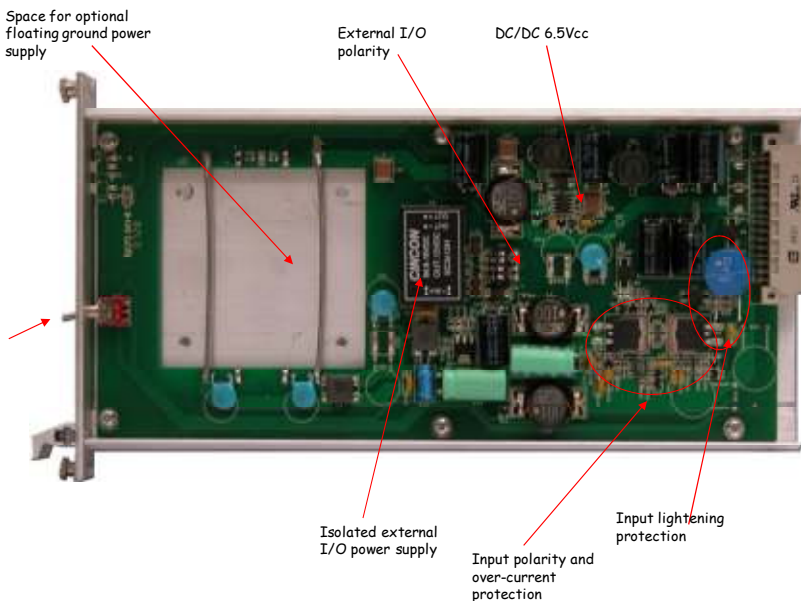

Equipment is power supplied by nominal 13,8Vdc from battery with negative shorted to ground and with a maximum current absorption of 5 A. In case of other power supply sources, other PSU models are available, DC/DC (nominal 12-24-48V, isolated) or AC/DC (nominal 220V) with battery charger.

### 3.2 DSP: DIGITAL SIGNAL PROCESSOR

The core of system's "physical layer" is this unit which via software performs every function of signal processing inside radio station. What other equipments implement by adding boards (like synchronizers, phase and amplitude equalizers, signal decoders, modem, etc.), here are implemented by routines which can be freely matched, down-loaded and with superior performance.

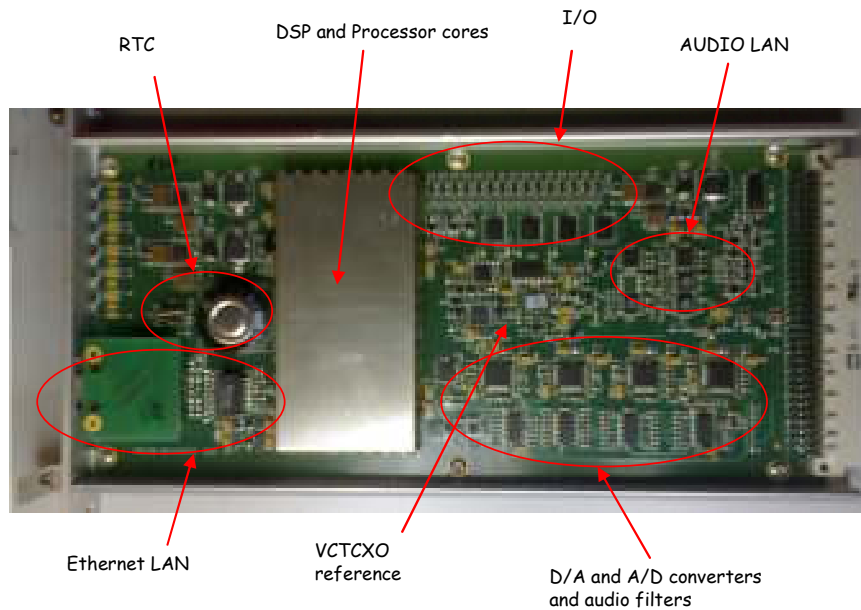

This board can process up to 8 analogical duplex signals ensuring 70 dB of SNR; it can manage 16 logical signals which can be configured both as input and output.

Communication and control functions of module are entrusted to a microprocessor which manages communications with external world and with other equipment modules. The microprocessor is based on LINUX operative system; it can manage a LAN ethernet 10/100 interface both for copper line and for fiber optic links, it is equipped with 4 serial ports to manage radio modules, GPS, auxiliary devices, external hosts; it is equipped with a Real Time Clock with tampon battery; it controls an embedded PLL to synchronize the entire station upon an internal (VCTCXO 0.5 ppm) or external temporal reference. DSP module is equipped with a synchronous serial port according RS485 standard levels, which can be programmed up to 16Mbit/s and can be used to interconnect together more transceiver or additional equipments.

Main performed functions are the following:

- ∞ Frequency self-tuning device
- ∞ Deviation self-calibration device
- ∞ Analogical and digital demodulation
- ∞ RF circuits testing
- ∞ Phase modulator calibration
- ∞ RF output power control
- ∞ Low frequency lines management
- ∞ DMR protocols management
- ∞ Digital signals processing
- ∞ Management, conditioning and routing of traffic and remote control signals from and towards external world

### 3.3 RECEIVER

Receiver can be supplied as single or double for space diversity reception. Main and diversity channels are completely independent and coherent (sharing the same local oscillators) and they are designed according to a triple conversion heterodyne structure, with 45 MHz and 10.7 MHz intermediate frequencies and with vectorial conversion to base-band.

Channel standard bandwidth is 12.5 KHz, but the receiver is prepared to accept also a settable channel bandwidth of 25 KHz (with double funnel option) for special applications.

Vectorial receiver gives to the DSP input the electromagnetic field vector, as received from antennas, without performing any demodulation. By this way the DSP can sum with the appropriate phases the received signals to obtain a "soft diversity" reception. This corresponds to an electronic antennas alignment in order to receive the maximum available information along the incoming signal direction.

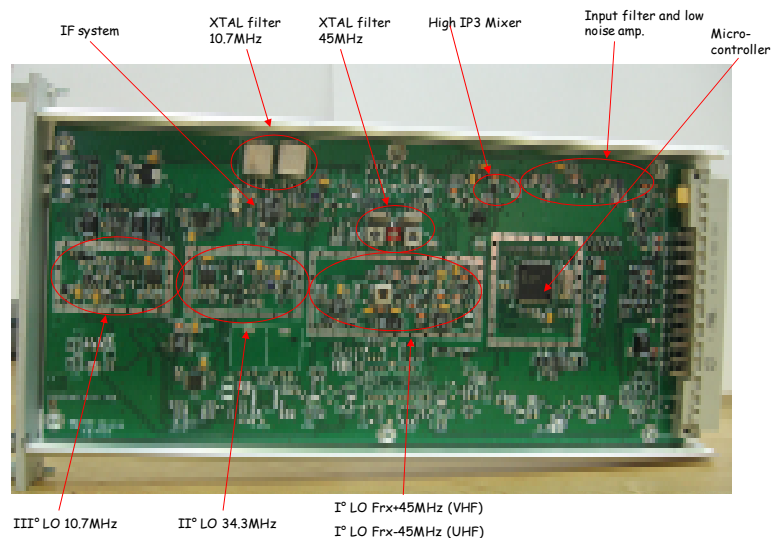

A further input (TX Test input), common for both receivers (main and diversity) is available, for the receiver self-test and for modulator calibration. Through a DSP command, the receiver can switch its input onto test signal generated inside transmission synthesizer module. That signal, amplitude calibrated by Factory, is modulated at receiving frequency and received by DSP. A fundamental test loop is close by this way.



The switching between normal and test input is implemented through PIN diodes.

Receiver modules is managed by a microcontroller unit whose program is hosted inside internal e2prom flash memory to lower parasitic emissions. This FW can be loaded through serial connection. The microcontroller, in addition to managing internal function of the unit, transfers measured parameters to the control unit through 115.2 Kb/s serial line.

The board is realized with surface mounting components (SMD) to maximally reduce dimensions.

Modular unit is housed in a shielded, 4TE high box for 220mm Eurocards. On the frontal panel 2 LEDs are placed for monitoring internal PLLs lock status.

### 3.4 TRANSMITTER

Transmitter module is realized with surface mounting components (SMD) and it is housed in a shielded, 8TE box for 220mm Eurocards, with an heatsink mounted on side, with a thermal resistance of about 1.2°K/W. The unit can be extracted from the front side of the rack.

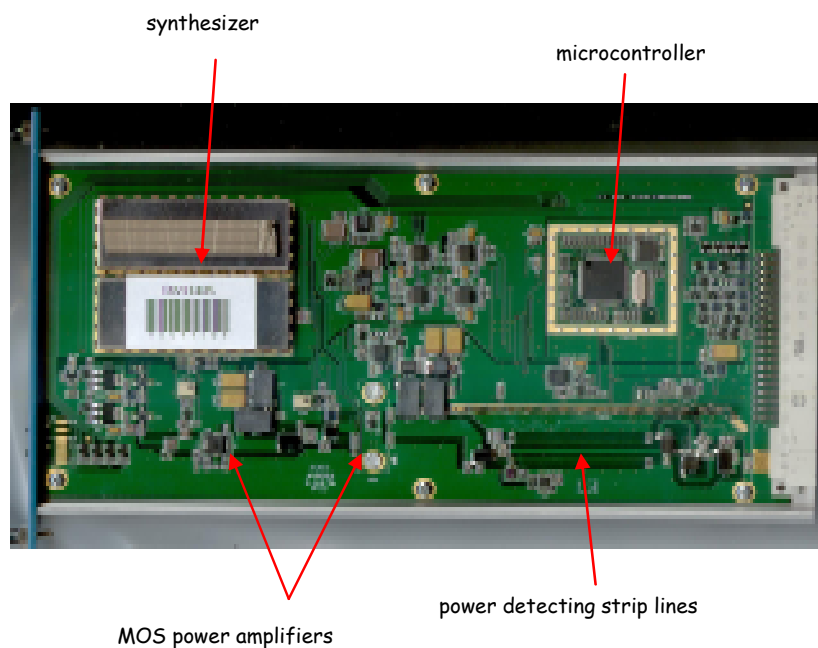

On the frontal panel two LEDs are placed to monitor the transmitter status.

Base-band functions, equalizing, limiting, low-pass filtering and eventual emphasis functions are performed by the DSP unit, which provides also for nominal and maximum deviation calibration by looping modulator with receiver.

Modulator is digital vectorial, then the synthesized signal by local oscillator implements the frequency shifting of the signal which has been directly modulated in base-band by DSP unit and transferred to transmitter through its I and Q components.

The amplifier is realized by three cascaded stages and RF output power regulation (between 1 and 25W) is implemented by controlling the gates voltages of MOSFET amplifier stages. Power amplifier works in C class and ensures a very high efficiency, lowering the needed power from supply system and lowering the thermal dissipation inside the cabinet. Direct and reflected output power are measured by a directional coupler. Power control circuit acts in a closed loop and keeps constant the total power at MOSFET drain. Inside the module a thermal sensor is hosted and it is directly connected to the internal microcontroller which enables the command for air forced cooling fan of the cabinet if the temperature rises over 85°C. Anyway, if reflected power or mosfet temperature exceeds protection threshold, regulation circuit will lower output power up to safe levels for transmitter.

The current flowing into final amplifier transistor is continuously monitored by microcontroller to verify the correct functioning and to reveal an eventual efficiency degradation.

The module is equipped with an harmonic filter to lower spurious emissions under required levels by existing regulations.

### 3.5 I/O AND SERVICES MODULE

I/O and Services module is a unit integrating different interfaces and functions, that for some applications can be optional but for others become essential. For this reason the module can be differently equipped with its different logical blocks, according to the particular application. The embedded block are the following:

- ∞ *Telephone line interface*: 2/4W+E&M line interface to remote analogical audio and perform automatic routing through telephonic line
- ∞ *Opto-isolated I/O*: 2 input + 2 output contacts programmable (both N.O. or N.C.) for remote monitoring local sensors and remote controlling local actuators
- ∞ *Opto-isolated alarms*: two alarms output (1 warning + 1 fatal)
- ∞ *Analogical input*: 2 not isolated inputs, 1 for voltage sensing (0..20V referred to ground) + 1 for current sensing (4...20mA). These input can be connected the first in parallel and the latter in series with the analogous ones of other similar equipments
- ∞ *GSM/GPRS modem*: embedded communication module for remote control if the site is covered by GSM or GPRS service. It requires only an external passive antenna
- ∞ *GPS receiver*: embedded receiver for GPS service, with high precision Pulse Per Second (PPS) output function in order to synchronize the station. Only an external active antenna is required
- ∞ *RS232 converter*: 115.2Kbit/s serial interface for remote control

I/O and services module is equipped with 8 LEDs on the frontal panel to monitor the status of opto-isolated I/O, the status of GPRS modem and the presence of PPS.

Modular unit is housed in a shielded, 4TE high box for 220mm Eurocards.

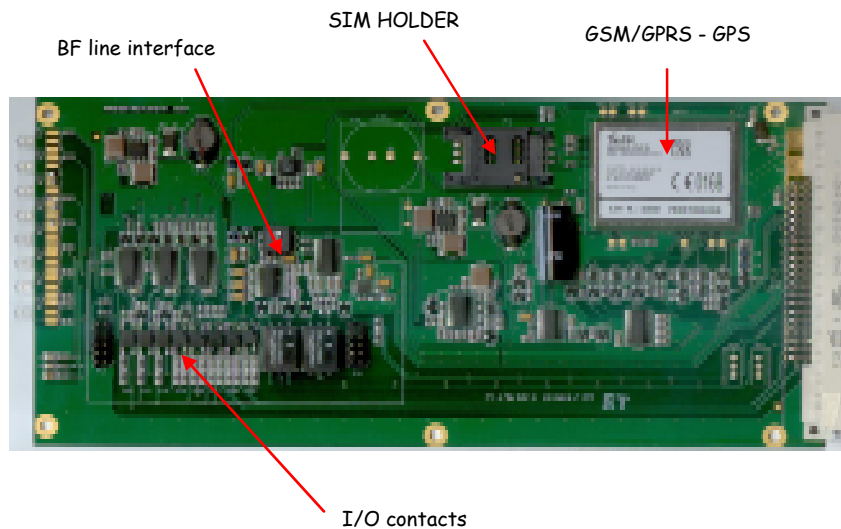

## 4 TECHNICAL DATA

### 4.1 REGULATIONS COMPLIANCE

Equipments are compliant with existing regulations, in particular:

1. **EN 300 086-2**: Technical characteristics and test conditions for radio equipment for analogue speech.
2. **EN 300 113-2**: Technical characteristics and test conditions for non speech radio equipment for the transmission of data.
3. **ETSI TS 102361**: Electromagnetic compatibility and Radio spectrum Matters (ERM); Digital Mobile Radio (DMR) Systems.

The equipment is able to manage OSI stack layers 1 – 2 – 3 of DMR protocol, making active interaction possible with mobile terminals.

### 4.2 GENERAL CHARACTERISTICS

Funnel	12.5 KHz (25KHz optional for special purpose)
Maximum channels number	200
Operating mode	Dual-standard, analogical and digital
Operating mode selection	Totally automatic
Frequency stability	+/- 0.5 ppm
I/O	4 opto-isolated OUT (2 alarms + 2 generic) 4 IN (2 digital opto-isolated + 2 analogical referred to ground)
Voice/data digital interface	LAN 10/100 copper or fiber optic
Analogical audio interface	2/4W + E/M (BCA-C/U optional)

Base Bandwidth	Audio 300-3400 Hz $\pm$ 1dB Modulation 0-5 KHz
Calibration and tests	Automatic at start-up and/or by remote control
Remote control	Via ethernet / serial RS232 / GPRS

### 4.3 IP INTERFACING

#### 4.3.1 LAN PROTOCOL

Protocols for voice packets	UDP/IP (ipv4), unicast (from RA-TI-XXX to master) and multicast (from master to RA-TI-XXX), with DSCP set to <b>"EF"</b> ( <i>Telephony service class</i> ), according to RFC 4594
Protocols for BS "internal" network control	UDP/IP (ipv4), unicast and multicast, with DSCP set to <b>"CS6"</b> ( <i>Network Control service class</i> ), according to RFC 4594
Protocols for remote control, setup and surveillance	UDP/IP and TCP/IP (ipv4) unicast and broadcast with DSCP set to <b>"AF13"</b> ( <i>High-Throughput Data service class</i> ), according to RFC 4594
Audio format	Analog: 64 kb/s – 8 bit x 8 KHz linear coded DMR: AMBE II+™ (Advanced Multi-Band Excitation)
Audio frame block net payload	Analog: 60 ms – 480 bytes/samples DMR selectable single/double timeslot: 60 ms – 27 bytes each timeslot

#### 4.3.2 LAN REQUIREMENTS

Jitter (deviation of averaged packet time delay)	The Base Station is able to compensate Jitter delay up to 200 ms. The total delay averaged + jitter must not exceeds 400ms (each way)
Maximum delay	The Base Station is able to compensate round trip delay less then 900ms (jitters included)
Packet loss	< 0.1 %
Minimum bandwidth (network signaling and remote control polling inclusive)	SLAVE: 70 kb/s in analog to/from Master 24 kb/s in DMR to/from Master (both timeslots)
	MASTER to serve <b>N</b> SLAVES (both timeslots): 70 kb/s in analog to Slaves, 70 kb/s x <b>N</b> from Slaves 24 kb/s in DMR to Slaves, 24 kb/s x <b>N</b> from Slaves

#### 4.3.3 PORTS AND CONNECTORS

UTP LAN Port	Ethernet 10BT/100TX (auto MDI/MDI-X) on an RJ45 socket
Optical LAN Port (option)	Ethernet 100FX on SC-SC socket
Serial control Port	RS232 V.24 asynchronous 600 ÷ 115200 bps on a DB9 female connector
BUS control Port	TTL on a dual-in-line 10 pins male connector

#### 4.3.4 CODEC VOIP

Uncoded audio source	64 kbps – 8bitx8KHz
Net bit-rate (1CH)	2450 bps
FEC Coded bit-rate (1CH)	3600 bps
Audio frame block	20ms

Coder algorithm	AMBE II+™ (Advanced Multi-Band Excitation)
DMR compatibility	Motorola Mototrbo series

#### 4.4 RADIO FREQUENCY

Radio Transceiver model RA080, RA160, RA450, RA900, typical values.

##### 4.4.1 TRANSMITTER

Module output power	1/5/10/15/20/25 W
RF final transistor protection to high temperature	85°C +/- 5°C progressively reducing the RF power
Available modulation	FM, PM, GFSK, 4FSK
Modulation bandwidth	0 .. 5000 Hz
Synthesis step	4/5/6,25/10 KHz
Transmitting duty cycle	Continued 100%
ROS protection	Min.10' in short circuit as well as in open circuit
Adjacent channel noise	-75 dBc @25KHz -65 dBc @12.5KHz
FM distortion	< 1.5 %
Noise	-56 dBp @25KHz -50 dBp @12.5KHz

Frequency stability	0.5 p.p.m.
Max reverse input signal	-20dBm to avoid intermodulation +20dBm no damage

#### 4.4.2 RECEIVER

Maximum sensitivity	-113 dBm @20 dBp SINAD -118dBm @5% BER without diversity -121dBm @5% BER with diversity
Operating maximum input	-10 dBm
Maximum input without permanent damages	+10 dBm
Reception mode	Vectorial I e Q
Received signal band	0..5000 Hz
Synthesis step	6,25 KHz
Co-channel protection	8 dB @25 KHz 12 dB @12.5KHz
Adjacent channel selectivity	73 dB @25 KHz 62 dB @12.5 KHz
Blocking protection	80 dB
Intermodulation protection	75 dB
Intercept 3° order IP3in	+15 dBm

Distortion	<2 %
Noise	-53 dBp @25 KHz -47 dBp @12.5 KHz -60 dBp (with voice search option)
Frequency stability	0.5 p.p.m.



#### 4.4.3 FREQUENCY BANDS

Model	Frequency band
RA-900	UHF – HH => 865-925 MHz
RA-450	UHF – H => 410-440 MHz
RA-450	UHF – L => 430-470 MHz
RA-160	VHF – H => 145-174 MHz
RA-080	VHF – L => 68-88 MHz

#### 4.4.4 COMMUTATION BAND (WITHOUT DUPLEXER)

Band	TX	RX
UHF – H	30 MHz	14 MHz
UHF – L	30 MHz	12 MHz
VHF – H	28 MHz	28 MHz
VHF – L	20 MHz	20 MHz

#### 4.4.5 BRANCHING REQUIREMENTS

##### 4.4.5.1 TX to antenna duplex isolation requirements @10W TX RF power

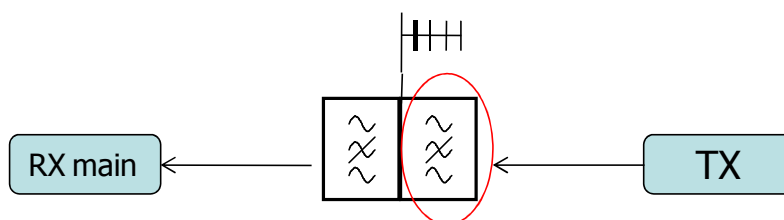

Band	+/-40MHz	+/-9MHz	+/-4.5MHz	+/-3MHz	+/-1.5MHz	+/-0.8MHz
UHF – HH	75dB					
UHF – H/L	75dB	75dB				
VHF – H	75dB	75dB	75dB	78dB	81dB	85dB
VHF – L	75dB	75dB	75dB	75dB	78dB	81dB

**4.4.5.2 Suggested RX max input limits on unwanted signals**

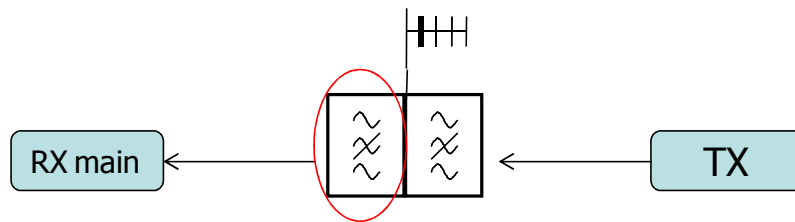

Band	+/-1MHz	+/-500KHz	+/-100KHz	+/-50KHz	+/-25KHz	+/-12.5KHz
UHF – HH	-32dBm	-43dBm	-45dBm	-47dBm	-49dBm	-58dBm
UHF – H/L	-32dBm	-41dBm	-43dBm	-44dBm	-48dBm	-56dBm
VHF – H	-32dBm	-40dBm	-42dBm	-43dBm	-47dBm	-54dBm
VHF – L	-32dBm	-36dBm	-38dBm	-40dBm	-43dBm	-50dBm

**4.5 OTHER SPECIFICATIONS**

**4.5.1 ENVIRONMENTAL PARAMETERS**

Operating Temperature	-25 ÷ +55 °C
Storage Temperature	-40 ÷ +70 °C
Relative Humidity	Max 80% not condensed

**4.5.2 POWER SUPPLY**

Nominal Voltage	11 - 15 Vcc (neg. ground) 19 – 36 Vcc (floating ground) 38 – 60 Vcc (floating ground)
Max ripple	30 mVpp
Polarity reversal protection	-70 V
Short-circuit protection	Electronic protection with automatic restore and double fuse on input line
Power consumption	TX: 55 W @20W RF RX: 8 W

**4.5.3 MECHANICAL CHARACTERISTICS**

Dimensions	128 x 426 x 280 mm 1/2 rack 19" x 3TU x 280 mm mounting
Weight	6.0 Kg

**4.5.4 AUDIO BALANCED INTERFACES**

Interface type	2/4 wires isolated balanced line on RJ45 socket
Line isolation	1500 V
Used audio bandwidth	300÷3400 Hz
Input/output Impedance	600 Ohm

Side tone reflection	< - 20 dB
Output nominal level	-20 .. 0 dBm
Input nominal level	-20 .. 0 dBm
Hang line current	10..50 mA
Level adjust	software by 0.1dB step
Ring detect	60..120 Vpp @25Hz
Ring generator (option)	90Vpp @25Hz
Release tone detection	3 pulses of 425Hz @50% duty 250ms/250ms

## 5 EQUIPMENT INSTALLATION AND MAINTENANCE

### 5.1 CONNECTIONS AND PINOUTS

RA-XXX base-stations require a reduced set of connections for normal working conditions (power supply, with optional “power good” and “inhibit” controls, antennas, eventual ethernet link for remote control or for multi-site link). The transceiver is equipped with other sockets in order to connect it to auxiliary equipment, like other transceivers, multi-receivers, audio interfaces, remote site control devices, fan cooler, and so on.

On the front side of the equipment there are only the 10BT/100TX ethernet connector for the remote control of the equipment and for data/audio packets communication, the power on/off switch and the LEDs for monitoring the status of the equipment. All other connectors are placed on the back side of the transceiver.

The following picture shows the fundamental connections in red color and the optional ones in blue color.

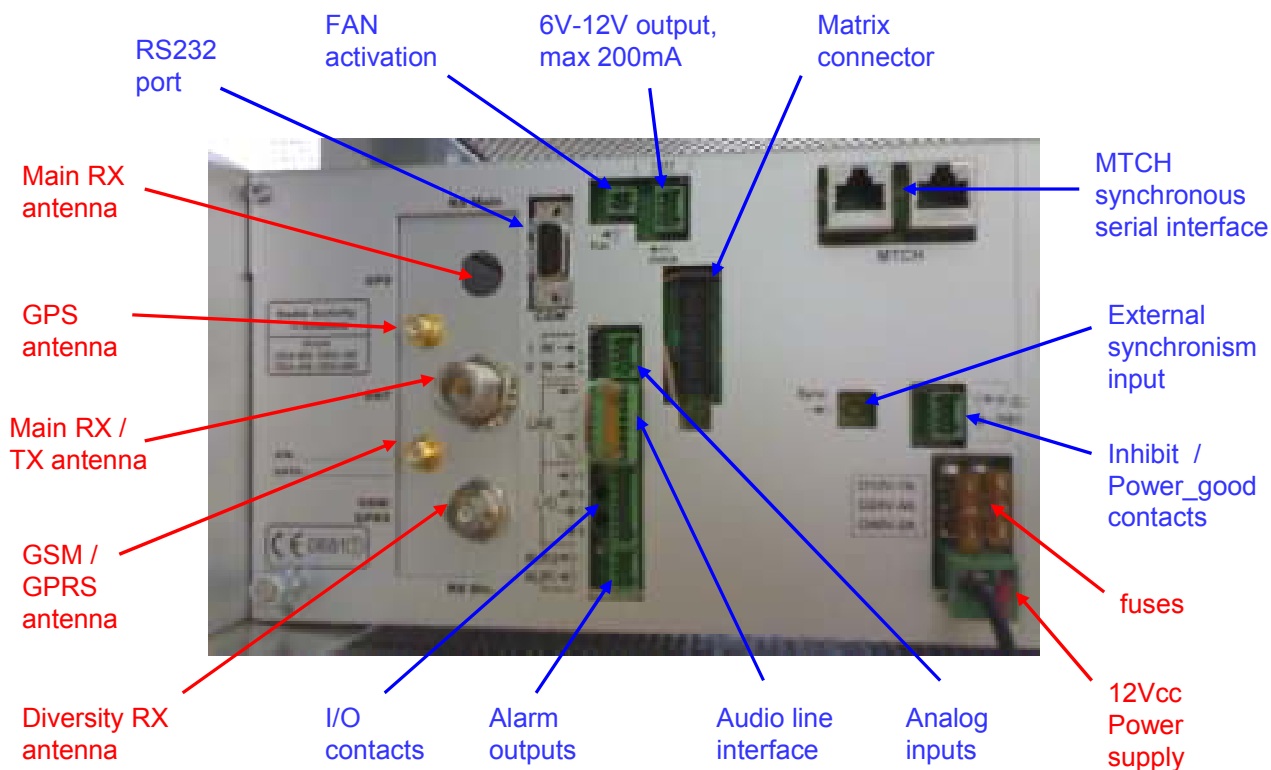

The following connections are available (for each one, a picture of the connector and the related schematic diagram of back plane PCB are shown):

- ∞ **Power Supply:** 13.2Vdc with negative to ground, or optionally 24Vdc or 48Vdc isolated. The equipment is protected from polarity inversion. Two automotive type 10A fuses work against accidental short circuits. The connector has 3 poles (+Vin, rack ground, -Vin) with 5.08mm pitch

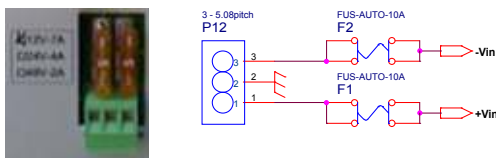

- ∞ **Power supply control:** normally closed optically isolated “PG” (Power Good) contact ensures the presence of internal correct supplies; “INH” (Inhibit) contact should be kept closed/open to switch off/on the equipment. Input contact is internally polarized with +/-12V.

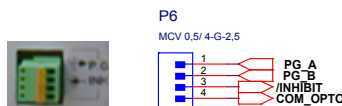

- ∞ **Antennas:** up to 5 antenna connectors can be mounted according to the specifications of equipment.
  1. A female N-type connector is connected to the output of the duplexer (if present) or to the output of the TX (if branching is not mounted inside the equipment);
  2. A female BNC-type connector (above the N-type one) is present if duplexer is not mounted inside the equipment. It is connected to main RX;

3. A female BNC-type connector (below the N-type one) is present if the base station is equipped with the diversity receiver. This connector is directly connected to the input of the diversity receiver, without any cavity filter/isolation inside the equipment. Care should be taken in designing external branching and radiant system;
4. A female SMA-type connector for embedded GPS receiver. The equipment supplies 5Vdc through this connector for the remote active antenna (which is requested with a minimum gain of 20dB and possibly equipped with a rejecting filter for out-of-band spectral components);
5. A female SMA-type connector for GSM/GPRS embedded transceiver. A passive antenna is required. (The SIM holder is mounted inside I/O module.).

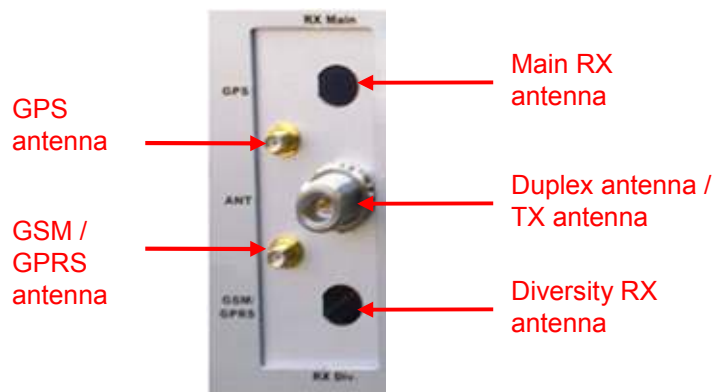

- ∞ **COM port:** 9 poles D-SUB type socket, connected to an optional RS232 serial port (115.2Kbit/sec, 8,N,1) for remote controlling the equipment by a PC. This is a secondary access port to the base station, auxiliary/alternative respect to the main ethernet port. The RS232 driver is mounted on the I/O module.

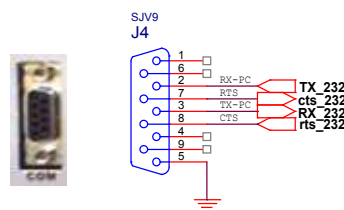

- ∞ **“Fan” and “Auxiliary power supply output”:** the first is an active low, open collector type contact, not isolated, which can activate an optional external cooling system if RF power amplifier temperature would rise over 90°C. In normal ambient and working conditions, no cooling system is required. The second connector supplies 12Vdc 200mA and 6Vdc 200mA (not isolated) for eventual auxiliary devices



- ∞ **“MTCH”**: two 8 poles RJ45 connectors (connected in parallel) give access to internal digital audio multichannel (synchronous, TDMA, 4Mbit/s speed, serial interface with custom protocol). These connectors are used to implement any particular system and network architectures which require the base station to be connected to other devices equipped with the same MTCH interface.

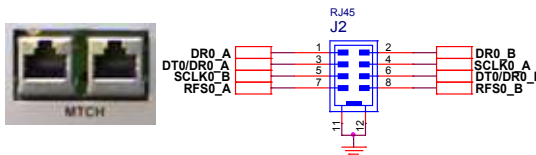

- ∞ **Analog inputs**: a 4 poles connector with 2 not isolated analog inputs, one for current (dc, from 0 to 20mA) and one for voltage (dc, from 0 to 20V referred to GND). Current inputs of different equipments can be connected in series; voltage inputs of different equipment can be connected in parallel.

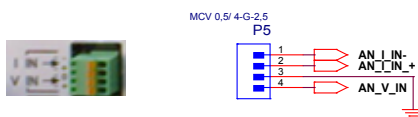

- ∞ **AF line interface**: a 8 poles connector to connect the base station to a telephone or console line (both 2 or 4 wire lines, also with E and M criteria) to monitor analog traffic only or for synchronization aim. Starting from the top, the pinout is as following: output line (use this contacts in case of 2 wire line – bidirectional -), squelch input contact (optically isolated, normally open), PTT output contact (optically isolated, normally open, internally polarized with +/-12V), input line(only for 4 wire line).

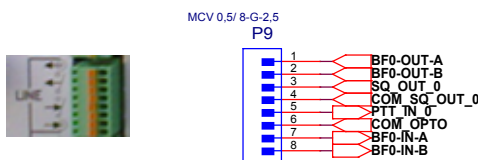

- ∞ **Digital I/O**: a 8 poles connector with 4 optically isolated digital contacts, 2 outputs (in the upper part, normally open) and 2 inputs (in the lower part, normally closed). Input contacts are internally polarized with +/-12V.

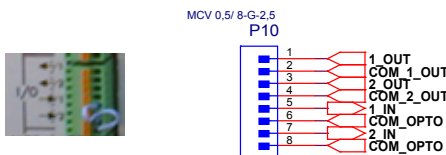

- ∞ **Alarm outputs**: a 4 poles connector with 2 optically isolated digital contacts (normally open). Alarm 2 output will be closed if the base station undergoes a temporary out of service or if a slight problem happens (warning); alarm 1 output will be closed during power on of the station or if a heavy problem happens (stable out of service).

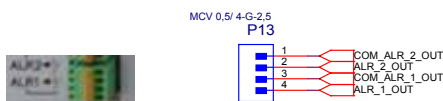

- ∞ **“Matrix” connector:** a 20 poles connector (2x10, pitch 2.54mm) and a coaxial MCX-type connector with a set of signals which can be used to implement any particular system and network architectures which require the base station to be connected to other devices equipped with the same MTCH interface.

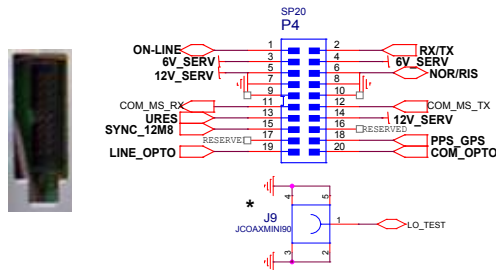

- ∞ **SYNC IN:** a MCX coaxial connector for eventual external synchronization input signal. Normally this input is unused, it is needed for special applications which require an external synchronization source (sinusoidal, at 12.8MHz, with level between -10 and 0 dBm).

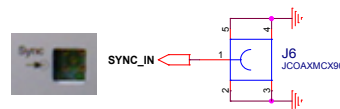



For example, the following picture shows how two repeaters should be connected to implement a simulcast network with **ethernet links**.

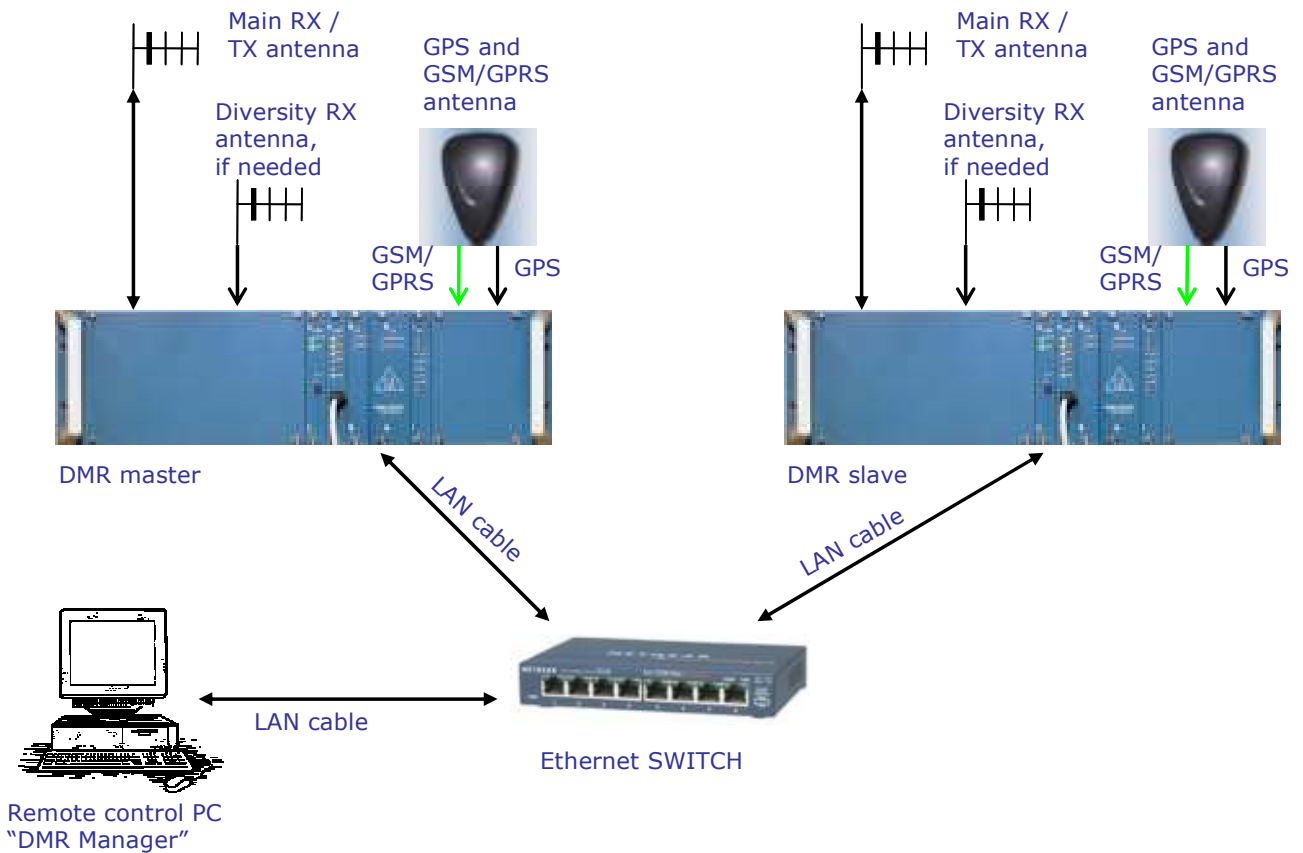

In case of UHF links, 2 transceivers are needed for each site, one for local broadcasting and the other for the link between master and satellite. They can be mounted into the same rack 19" 3U. The following picture shows the back side of a RF linked satellite.

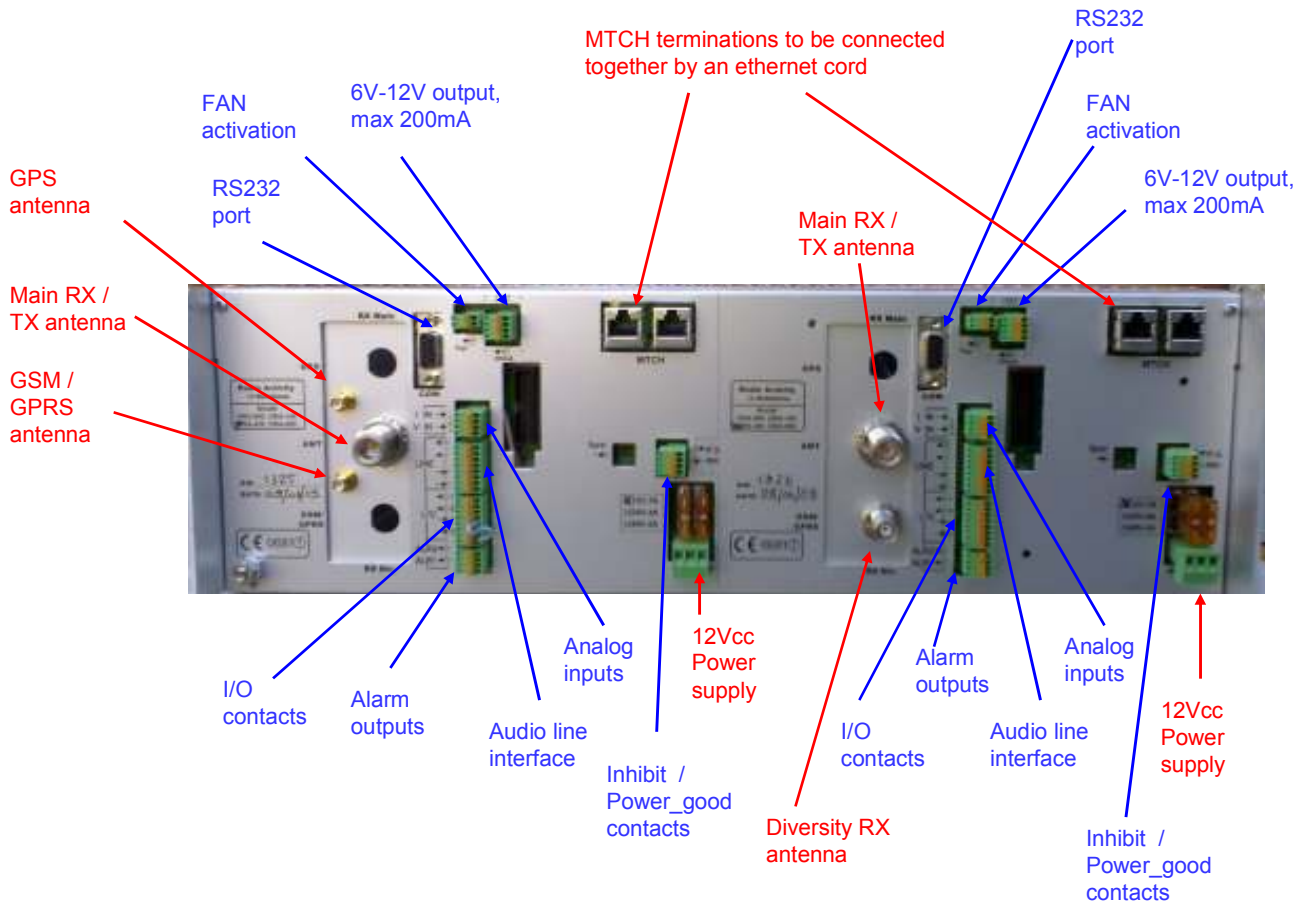

For this example, the following picture shows how two repeaters should be connected to implement a simulcast network with **UHF links**. Two ethernet patch cord are needed to connect together the MTCH ports and the ethernet ports of the two radios; they are represented in pink color.

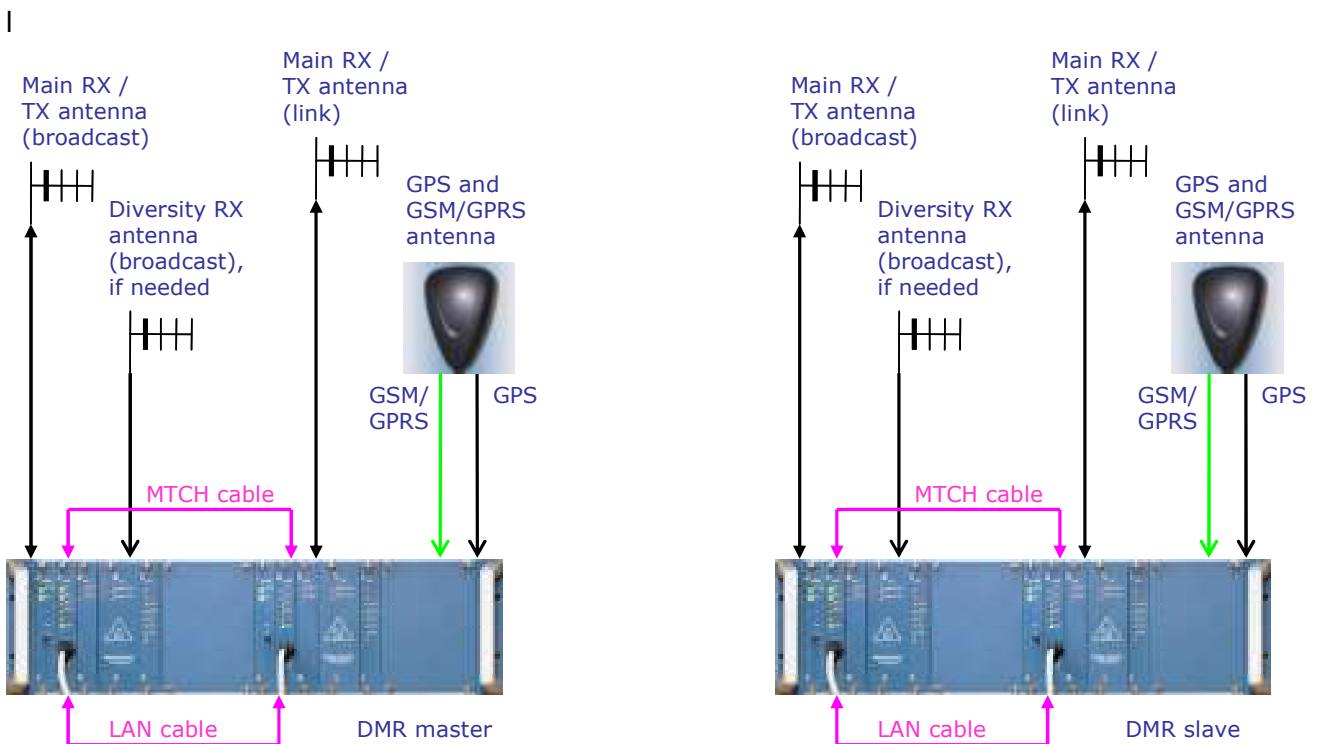

## 5.2 EQUIPMENT START UP, RUNNING AND ALARMS: INDICATOR LAMPS

The base stations of RA-xxx series are designed to reduce as much as possible the maintenance work. To this aim, specific solutions have been implemented to prevent aging drifts.

Each time the base station is switched on, a self-calibration process is performed in order to finely tune the modulation and the demodulation parameters. This process checks the total loop BF-TX-RX-BF by looping the synthesizer output of the TX on the input of the RX and the DSP unit can store the results into flash memory and update the older ones which have been previously saved. The correct results of a calibration process are symptom of an optimal tune of the radio transceiver. If the calibration process ends with errors, the transceiver can anyway work correctly by loading the older tuning parameters and the newer ones are not saved.

On the frontal panel of the RA-xxx base stations, there are some LED lamps for monitoring the status of the equipment. They have different meanings, during power on process, respect to normal running condition. Here following, a description of the meaning of the LEDs, grouped module by module. In general, if the equipment works correctly, all leds are off or green; if a warning arises, one or more leds start flashing in red color; if a problem or an alarm arises, one or more leds are red. (An exception should be made for eventual leds which show the status of line output criteria: they are red if the corresponding criteria are enabled).

### 5.2.1 PSU

When the base station is switched on, the 2 leds of PSU module should be green both:

- ∞ the upper led is red if the supplied input voltage is too low or too high; it is off in case of inverted polarity of connection to power supply system; it is green if the supplied input voltage belong to the correct working range;
- ∞ the lower led is green if the secondary internal voltages are correctly supplied by PSU module, otherwise it is off.

### 5.2.2 DSP

When the base station is switched on, DSP module performs a booting process, during which the upper 4 leds are orange; the lower 2 leds respectively monitor the activity through ethernet connection (the 5<sup>th</sup> led flashes with orange color during data communication) and the connection to ethernet network (the 6<sup>th</sup> led is green if the connection is established), therefore they are independent from the logical status of the module. At the end of the booting process, the DSP module executes the following steps in sequence, which are also visually indicated by leds:

- ∞ FW uploading to clock generator (3<sup>rd</sup> led flashes in orange color);
- ∞ FW uploading to DSP and reset of peripheral modules (2<sup>nd</sup> led flashes in orange color)
- ∞ DSP startup (1<sup>st</sup> led flashes in orange color)
- ∞ RX self-calibration (2<sup>nd</sup> led flashes in red color)
- ∞ TX self-calibration (1<sup>st</sup> led flashes in red color)
- ∞ TX→RX loop self-calibration (3<sup>rd</sup> led flashes in red color)

- ∞ Frequency setup of working channel (1<sup>st</sup> led flashes in red color in case of fine calibration of parameters)

At this point the DSP reaches its normal running status and the leds behave as follows:

- ∞ 1<sup>st</sup> upper led: it flashes in green color if calibration of TX failed; it is green during transmission on TS1; it flashes in red color if multichannel is enabled but the DSP cannot receive data correctly (this function will be assigned to the 2<sup>nd</sup> led in future SW version); otherwise it is off;
- ∞ 2<sup>nd</sup> led: it flashes in green color if calibration of RX failed; it is green during transmission on TS2; it flashes in red color if multichannel is enabled but the DSP cannot receive clock correctly (this function will be assigned to the 3<sup>rd</sup> led in future SW version); otherwise it is off;
- ∞ 3<sup>rd</sup> led: it flashes in green color if calibration of TX→RX loop failed; it is green during reception from TS1; otherwise it is off;
- ∞ 4<sup>th</sup> led: it flashes in green color if the system clock is locked to the synchronism source; it is green during reception from TS2; it flashes in red color if the DSP is not locked to the synchronism source as set in "AFC" routine; otherwise it is off;
- ∞ 5<sup>th</sup> led: it flashes in orange color during data communication through ethernet port; otherwise it is off;
- ∞ 6<sup>th</sup> led: it is green if the ethernet connection is established; otherwise it is off.

During analog transmission (or reception), both the leds related to transmission (or reception) on TS1 and TS2 are green, because both the timeslot are busy during analog communication.

### 5.2.3 RX

RX module is equipped with two leds:

- ∞ the upper led flashes very fast in green-red color during data reception-transmission through control serial port of the module (during FW upload process on peripheral microprocessor); it is red in case of unlock of the upper local oscillator which is used to tune the RX; otherwise it is off;
- ∞ the lower led flashes in red color if there is no application (main) FW uploaded to peripheral microprocessor; it flashes in green color during start-up booting process; it is red in case of unlock of at least one of the IF local oscillators; otherwise it is off.

### 5.2.4 TX

TX module is equipped with two leds:

- ∞ the upper led flashes very fast in green-red color during data reception-transmission through control serial port of the module (during FW upload process on peripheral microprocessor); it is red in case of unlock of the local oscillator or during transmission if the generated RF power is less than a half of its set value; it is green during transmission with a greater RF power than 10W; otherwise it is off;
- ∞ the lower led flashes in red color if there is no application (main) FW uploaded to peripheral microprocessor; it flashes in green color during start-up booting process; it is red in case of excessive SWR and consequent forced interruption of transmission; it is green during transmission with a lower (or equal) RF power than 10W; otherwise it is off.

### 5.2.5 I/O

I/O module is equipped with eight leds, of which the upper 6 reflect the status of corresponding digital I/O contacts that are present on the back side of the equipment, while the lower 2 reflect the status of the embedded GSM/GPRS-GPS device. They behave as follows:

- ∞ the upper led is red if a heavy problem happens to the base station or during its booting process (meaning a stable out of service status); the corresponding alarm 1 is active; otherwise the led is off;
- ∞ the 2<sup>nd</sup> led is red if the base station undergoes a temporary out of service (example during a channel change) or if a slight problem happens (warning); the corresponding alarm 2 is active; otherwise the led is off;
- ∞ the 3<sup>rd</sup> led is green if the output contact 1 is active (normally open);
- ∞ the 4<sup>th</sup> led is green if the output contact 2 is active (normally open);
- ∞ the 5<sup>th</sup> led is green if the input contact 1 is active (normally closed);
- ∞ the 6<sup>th</sup> led is green if the input contact 2 is active (normally closed);
- ∞ the 7<sup>th</sup> led flashes in green color if PPS signal is generated (Attention: after the first reception of a valid GPS signal for generating PPS signal, this signal is always generated by the module, it is eventually locked to local clock of the device in case of temporary unlock with GPS reference. The DSP module checks its effective validity); otherwise it is off;
- ∞ the 8<sup>th</sup> led flashes in green color if embedded GSM/GPRS module is enabled; it flashes fast if the SIM card is missing, slower if the SIM card is present; it is red during transmission of GSM bursts; otherwise it is off.

## 5.3 GENERAL RECOMMENDATIONS AND NOTES

### 5.3.1 *IMPROPER USE*

It is recommended to install the equipments in closed cabinet, to allow only authorized people to access to them, in order to avoid handling or improper use of equipments and to avoid accidental contact with hot surfaces.

### 5.3.2 *THERMAL DISSIPATION*

Outlet cabinet containing the equipments should be designed to ensure a good internal air flux for heating dissipation. A free slot of at least 1UT is recommended between two near equipments.

In case RF transmitter is set for its maximum power, it is active with a duty-cycle near to 100% and ambient temperature could be above 40°C, a larger respect area must be considered around the rack and an air forced cooling system should be eventually designed ("FAN" contact of the equipment can be used to switch on and off cooling system). The transmitter is protected against over-temperature: if the RF mosfet temperature arises over 90°C, the microprocessor will automatically decrease the generated RF power in order to make the amplifier work in safety conditions. The nominal RF power will be restored as soon as the mosfet temperature will decrease below 60°C.

### 5.3.3 *POWER SUPPLY SYSTEM*

Internal power supply voltage is nominally set to 13.2V dc from battery, with negative pole connected to ground, and it is protected against polarity inversion, over-voltage, under-voltage, short-circuits. Isolated PSU modules can be optionally supplied for 12V/24V/48V dc input voltage.

The equipment is designed to be powered by a safe supply source which grants a double insulation of output voltage from dangerous voltages. The electric plant must contain a switch to cut off power supply lines, according to national law and directives.

It is recommended to use power supply sources with low impedance output stage to make the hot swap controller of PSU properly work. For example, if power supply has an output filter with an inductive equivalent impedance, a capacitor can be added in parallel in order to reduce the resulting output impedance.

Power supply cable dimensions must be calculated for a maximum current absorption of 7A @13.2V DC, or 4A @24V, or 2A @48V, in order to avoid significant voltage drop, especially after fast transient. They should be protected by a fuse or a short circuit protection system which should be placed as near as possible to power supply source.

The transceiver is equipped with a couple of automotive type fuses, placed near power supply input connector, for short circuits protection. This type of fuses is designed for battery up to 55 Ah; for bigger battery power, other more effective devices should be placed before the transceiver to grant a correct power cut off.

It is also recommended to connect a good ground reference to the rack and to its metal components, by using both central pin of power supply connector and the screw on the right side of the rack. A second screw for ground connection is placed on the back side of the rack.

#### 5.3.4 ANTENNA

Antenna dischargers are recommended to prevent damages due to eventual atmospheric discharges. These devices should be placed on antenna connection cable, just before equipment's installation shelter, and they must be connected to an optimum ground reference.

Attention must be paid also to connect the eventual diversity receiver to the radiant system: the input of this receiver is directly connected to BNC connector on the back side of the rack, without any filter. The corresponding antenna must be placed far enough from the transmitting antenna in order to avoid receiver desensitization and to get the correct isolation. To avoid any problem, it is recommended to insert a notch or a pass-band cavity to protect the receiver.

If an external branching is connected to the equipment, it must be designed to ensure the needed isolations between transmitter and receivers.

#### 5.3.5 AF INTERFACE

If a 2/4W telephone line is connected to the equipment, external primary dischargers are recommended to prevent damages due to eventual atmospheric discharges on the line. The internal AF interface is protected only by secondary dischargers.

#### 5.3.6 MANUAL SETTINGS

The equipments of RA-xxx series are designed to minimize the set of needed hardware settings. Before installing the equipments the following manual settings must be verified if digital I/O and AF interface are used respectively:

- ∞ voltage polarity, used to supply the optically isolated digital input contacts: inside PSU module, a 4 poles dip-switch allows to set the polarity, according the following table:

1 ON	
2 ON	+12V
3 OFF	
4 OFF	
1 OFF	
2 OFF	-12V
3 ON	
4 ON	

- ∞ AF line interface characteristics: inside I/O module, a 2 pole dip-switch allows to set the line type (2W or 4W) and the input impedance of eventual 4W line (600 ohm or high), according the following table:

1 ON	Zin (4W) = 600 ohm
1 OFF	Zin (4W) = High
2 ON	2W
2 OFF	4W

### 5.3.7 SELF-CALIBRATION PROCESS

During self-calibration process internal parameters of modulator and demodulators are tuned by generating a signal through the synthesizer of the transmitter, by automatically connecting its output to the input of the receiver and by analyzing the received signal. If a strong signal is received by the external antenna during self-calibration, it is possible that the process ends with errors (a corresponding “warning” alarm will be displayed on both frontal leds and monitor of PC for remote control). In this case the DSP will load from flash memory the previously saved parameters without any problem for the transceiver.

To obtain better results from self-calibration process, it is recommended to set the calibration frequency as near as possible to the transmitter frequency; if there is a range of allowed frequencies for transmission, it is recommended to set the centre of this range as the calibration frequency.

### 5.3.8 PPS SIGNAL

For applications in simulcast networks where the source of synchronization is the PPS signal by GPS, if this signal is missing, the radio coverage of the areas which are reached by several repeaters with the same field strength, is not ensured. Attention must be paid in choosing and placing the GPS antenna.