

Owner's Manual

1/25 Scale Radio Control Tank
M1A2 ABRAMS TANK

Printed in MALAYSIA

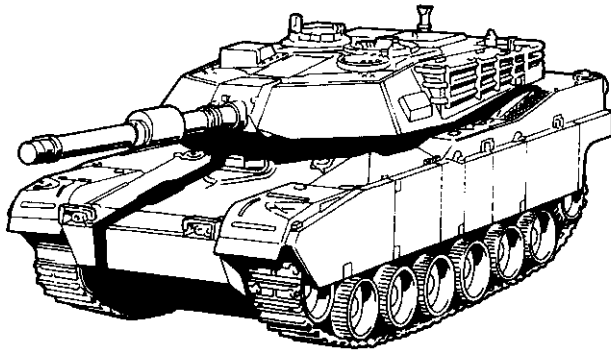

CAUTION: ELECTRIC TOY
Not recommended for children under 8 years of age. As with all electric products, precautions should be observed during handling and use to prevent electric shock.
Input: 120 vac, 60 HZ 12W only.
Output: 12 VDC, 3.6W

ATTENTION PARENTS
It is recommended that this toy and all accessories be periodically examined for potential hazards and that any potentially hazardous parts be repaired or replaced.



RadioShack®

- Please read carefully before starting to operate.
- "Warning! use under the direct supervision of an adult.
- KEEP THE DISPLAYBOX AND THE MANUAL FOR FUTURE REFERENCE.

FEATURES

- * 2-channel 9-function vehicle with forward-reverse drive, left-right turn, left-right spin, and stop functions.
- * Turret can be turned to the left/right by transmitter operation.
- * 2-motor system enables circular (spin) turns.
- * Real-sound system (Firing sound, idling sound, caterpillar rolling sound)
- * LED light-up

BATTERY REQUIREMENTS

- * Transmitter: One 9V(006P) battery
- * Tank: Ni-Cd cassette pack (6.0V)

English

NAMES OF THE PARTS

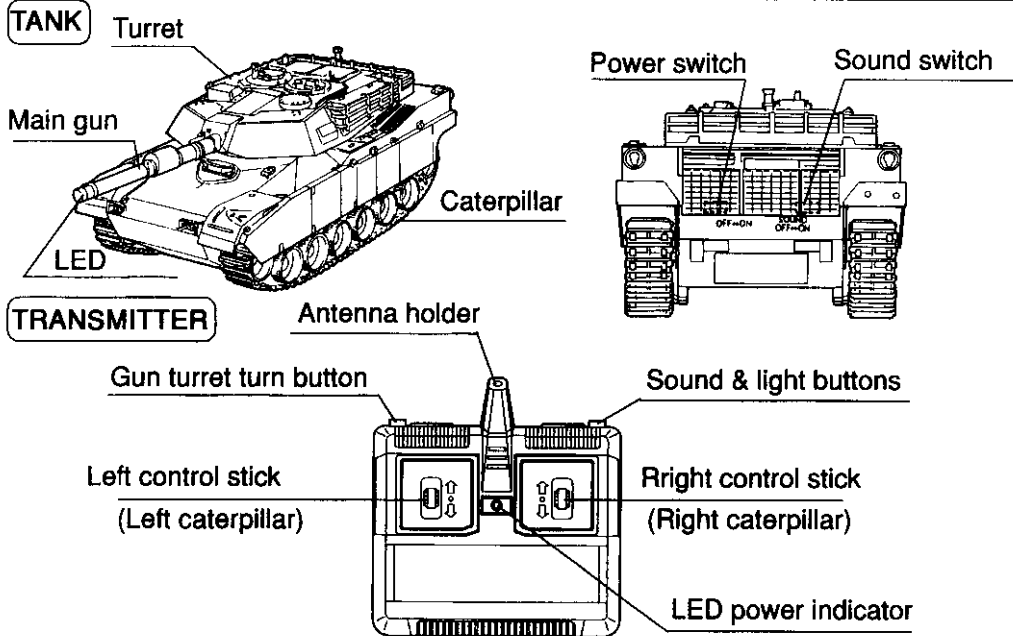

RECHARGING

* The newly purchased Ni-Cd pack(6.0V,600mAh)is not charged. Recharge before starting.

- ① Install the Ni-Cd battery pack into the battery compartment of the battery charger.
- ② Plug the charger into an ordinary household outlet.

* The (LED)light on charger should light up when the battery pack is being charged.
* Average recharging time is approximately 4 to 5 hours.

- ③ When the recharging is over, remove the charger from the household outlet.
- ④ Push the lever of battery charger and disconnect the battery pack from the battery charger.

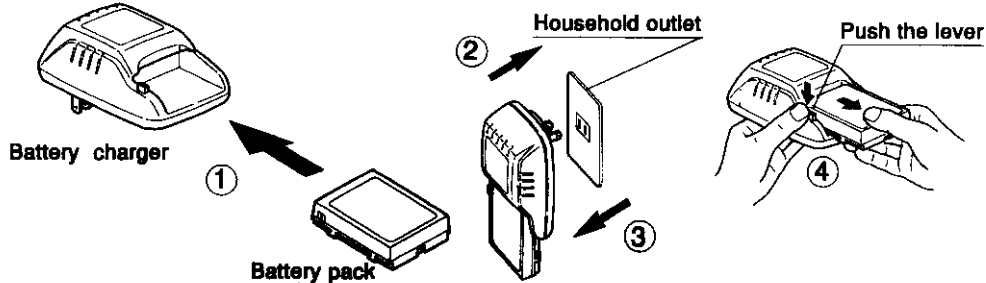

Caution

- Charge only nickel cadmium type rechargeable batteries. Other types of batteries may burst causing injury to persons and damage.
- Never let the charger or battery pack get wet or damp.
- Overcharging can damage the battery pack. Follow the indicated recharging time.
- Do not recharge in high temperatures or bring the battery pack near a flame.
- Check the batteries regularly for leakage.
- Remove empty batteries from the vehicle.
- Never try to charge non-rechargeable batteries.
- Removable batteries which can be recharged must be removed from the vehicle prior to charging.
- Do not take the charger or battery pack apart.
- Do not recharge the battery pack while it is still heated after use. Wait until it cools to recharge.
- Rechargeable batteries may only be charged under the supervision of an adult.
- Use only the recommended batteries or batteries of equal quality.

PREPARATION FOR OPERATION

How to attach the transmitter antenna

Insert the antenna in the antenna holder of the transmitter and screw in clockwise to fasten in place.

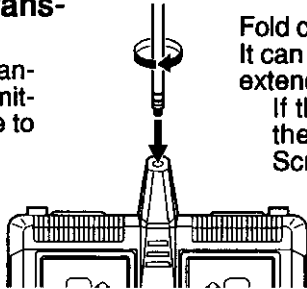

Fold down the antenna before attaching. It can be dangerous to try and attach an extended antenna.
If the antenna is screwed in loosely, the tank may not function properly. Screw in the antenna securely.

BATTERY INSTALLATION

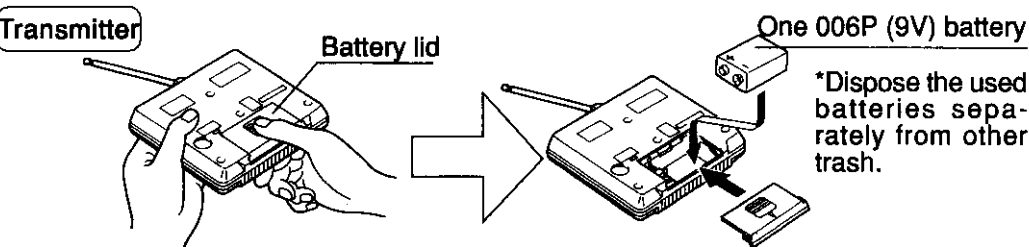

Transmitter **Battery lid** **One 006P (9V) battery**

*Dispose the used batteries separately from other trash.

① To remove the battery lid, press the place marked "OPEN" and slide the lid downward. ② Install the battery in the right direction

English

TANK Make sure that the power switch of the tank is turned OFF before installing the battery.

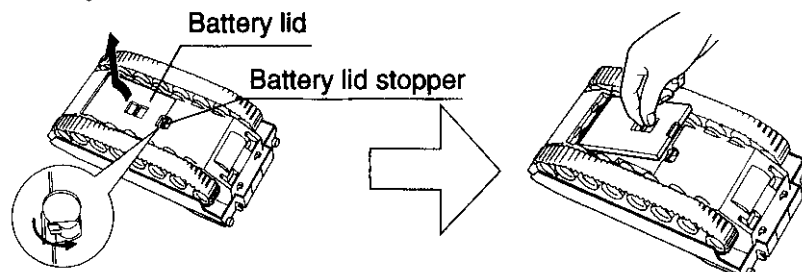

- ① Turn the battery lid stopper with a coin, as shown in the diagram.
- ② Pull up the battery lid to open.

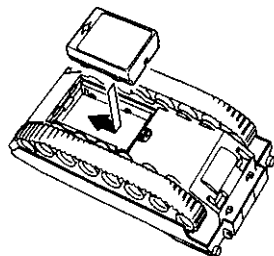

- ③ Install the Ni-Cd cassette pack in the battery compartment as shown in the diagram. The Ni-Cd cassette pack is designed so that the + and - poles must be positioned properly or else the pack cannot be installed.

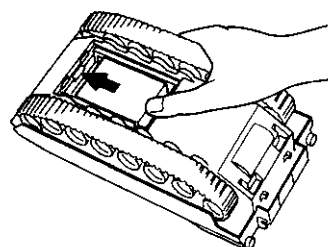

- ④ Slide the Ni-Cd cassette pack forward as shown in the diagram. The battery compartment lid cannot be closed unless the pack is pushed all the way in to the end.
- ⑤ Close the battery lid, and move the battery lid stopper back to the original position.

HOW TO OPERATE

1. Extend the transmitter antenna to its full length. The tank can be controlled to a longer distance by holding the transmitter upright as high as possible.
2. Move the control stick of the transmitter. (The LED power indicator will light up.)

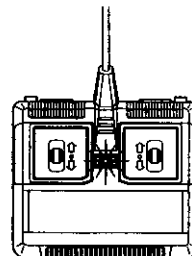
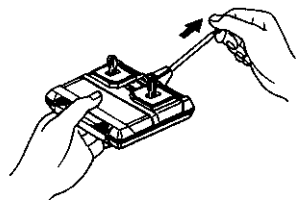

* Auto Power Off transmitter (With power save function): If the transmitter is not operated for a while, the transmitter will power off automatically.

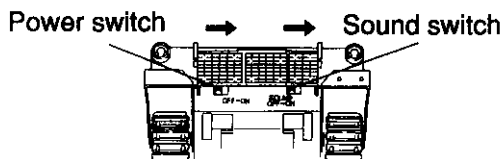

English

When the tank is operated, it will start to emit the caterpillar rolling sound.

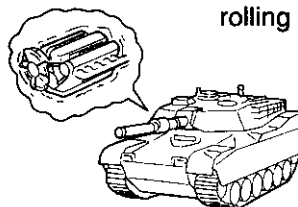

3. Turn the power switch of the tank ON. When the sound switch is turned ON, the tank will emit an idling sound, caterpillar rolling sound, or firing sound.

★ The sound can be stopped by turning the sound switch OFF.

4. Transmitter operations and tank movements.

● Straight forward movement ● Straight reverse movement ● Circular turn (clockwise)

● Forward right turn ● Reverse right turn ● Circular turn (counterclockwise)

● Forward left turn ● Reverse left turn

Turning the turret

● When the TURN button on the transmitter is pressed, the turret will make repeated turns to the left and right.

● When the FIRE button on the transmitter is pressed, the LED lamp at the tip of the main gun will light up and the firing sound is emitted.

English

5. When you have finished playing, turn the power switch and the sound switch of the tank OFF.
6. Remove the batteries from the transmitter and the tank.

Power switch Sound switch

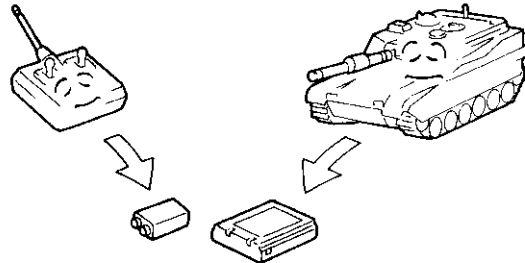
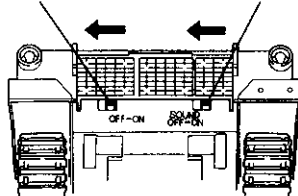

OPERATING SAFETY RULES

Select a **SAFE** place to operate your vehicle. Do not drive in the street. Avoid driving on **SAND** or through puddles of **WATER**. These hazards can impair performance. Check the surface ahead of you and watch for obstacles. The radio receiver in your vehicle and transmitter are sensitive instruments. Do not leave Vehicle or Transmitter near sources of **HEAT** or under **DIRECT SUNLIGHT** for long periods of time.

Avoid leaving Vehicle or Transmitter **OUTSIDE OVERNIGHT**. **NIGHT DAMPNES** IS HARMFUL to **INTERIOR MECHANISM**.

DO NOT try to take apart or remodel any of the parts.

CHANGES OR MODIFICATIONS NOT EXPRESSLY APPROVED BY THE MANUFACTURER FOR COMPLIANCE COULD VOID THE USER'S AUTHORITY TO OPERATE THE EQUIPMENT.

RADIO INTERFERENCE: Sometimes erratic behavior or loss of control of vehicle is the result of interference caused by high tension wires, high voltage transformers certain types of building, concrete walls or narrow places where **RADIO SIGNALS** sent from your transmitter **MAY BE SCATTERED** thus making it **DIFFICULT** for your vehicle to receive a **GOOD RADIO SIGNAL**. If you encounter this type of behavior or loss of control, **CHANGE TO A DIFFERENT LOCATION**.

You will encounter **INTERFERENCE** if **ANOTHER** radio controlled vehicle or **CB** radio is operating in the vicinity on your **SAME FREQUENCY**.

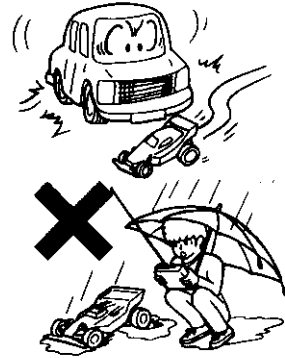

Cleaning and maintenance:

This toy vehicle needs periodic maintenance and cleaning.

Warning to the parents

The charger for the Ni-Cd battery pack needs periodic inspection to see that the lead wires, plugs, outer case, and other parts are not damaged in any way. If any of the parts are damaged, do not use the charger until it is completely repaired.

Caution

Keep out of reach of small children under 36 months old as there is danger of getting hurt.

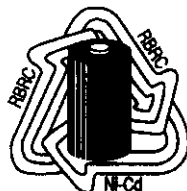

THE RBRC™ Seal on the nickel cadmium battery pack indicates that NikkoAmerica is voluntarily participating in an industry program to collect and recycle these batteries at the end of their useful life. The RBRC program provides a convenient alternative to disposing nickel-cadmium batteries into the trash or municipal waste stream, which is illegal in some areas.

Nikko America's payments to RBRC makes it easy for you to drop off the spent battery pack at local retailers who sell replacement nickel-cadmium batteries.

You may also contact your local recycling center for information on where to return the spent battery pack.

RBRC is a trademark of the Rechargeable Battery Recycling Corporation.

THE FCC WANTS YOU KNOW

This device complies with part 15 of the FCC Rules, Operation is subject to the following two conditions:

(1) This device may not cause harmful interference.

(2) This device must accept any interference received, including interference that may cause undesired operation.

Your R/C car might cause TV or radio interference even when it is operating properly.

To determine whether your R/C car is causing the interference, turn off your R/C car.

If the interference goes away, your R/C car is causing the interference.

Try to eliminate the interference by:

- Moving your R/C car away from the receiver.
- Contacting your local store for help.

If you cannot eliminate the interference, the FCC requires that you stop using your R/C car.

CAUTION

- *Check the batteries regularly for leakage.
- *Remove empty batteries from the toy.
- *Never try to charge non-rechargeable batteries.
- *Rechargeable batteries may only be charged under the supervision of an adult.
- *When inserting the batteries take care not to reverse their polarity.
- *Never use batteries of different manufacturers, and do not mix old and new batteries.
- *Use only the recommended batteries or batteries of equal quality.
- *Never short-circuit the terminals.
- *Removable batteries which can be recharged must be removed from the toy prior to charging.

*** CHANGES OR MODIFICATIONS NOT EXPRESSLY APPROVED BY THE MANUFACTURER FOR COMPLIANCE COULD VOID THE USER'S AUTHORITY TO OPERATE THE EQUIPMENT.**