

RadioShack
Dr. Seuss'
The Cat in the Hat
S.L.O.W. Vehicle
 60-4349

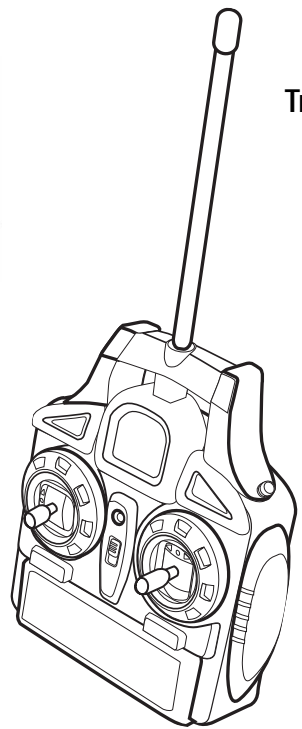

Transmitter

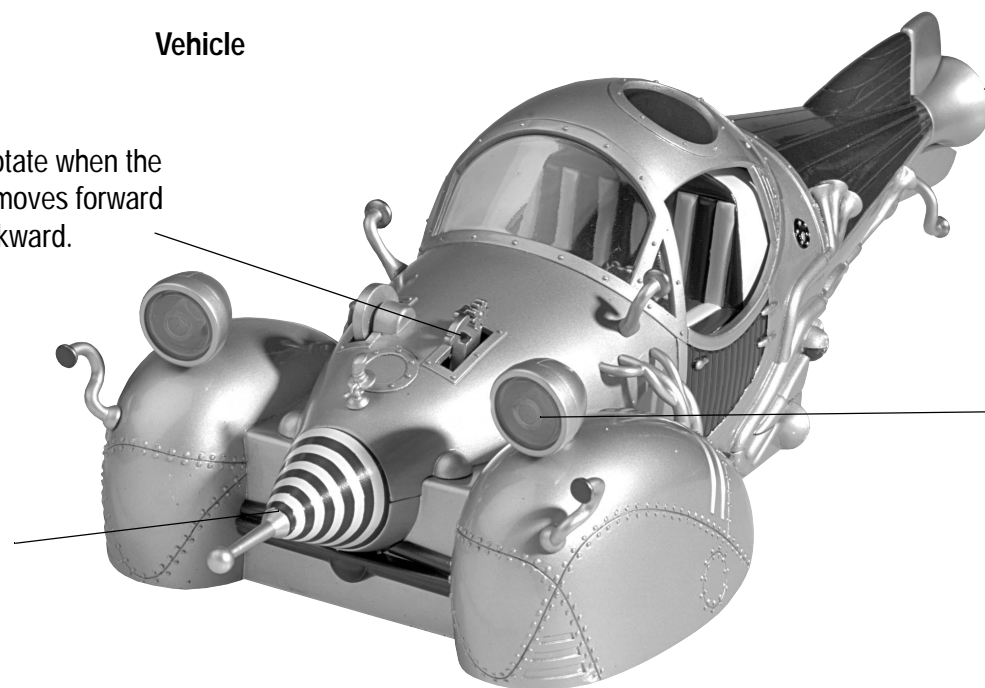

Vehicle

Red light illuminates when the vehicle moves in reverse.

Gears rotate when the vehicle moves forward and backward.

Lights move side to side when the vehicle moves left and right.

The cone spins when the vehicle moves forward or backward.

What's Included

- Vehicle
- Transmitter
- Battery box for AA batteries

Step One

Installing the Transmitter Battery

Your transmitter requires one 9V battery (not supplied) for power. When the transmitter's range decreases, replace the battery.

1. Slide **ON/OFF** on the transmitter to **OFF**.
2. Slide the battery compartment cover in the direction of the arrow to remove it.
3. Place the battery in the transmitter as indicated by the polarity symbols marked inside.

4. Replace the cover.

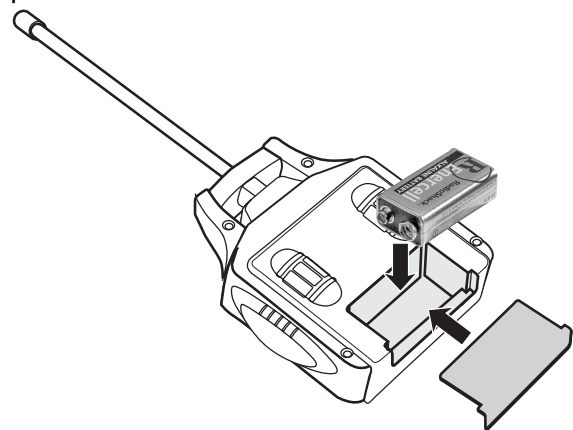

Step Two

Installing the Vehicle Battery Pack

Your vehicle requires either four AA batteries or one 6V rechargeable battery pack (neither supplied).

In the Vehicle

1. Slide **ON/OFF** on the vehicle to **OFF**.
2. Use a coin to turn the battery compartment latch in the direction of the arrow to open it.
3. Use a coin to loosen the screw on the battery adapter cover, and remove the cover. Insert four AA batteries according to the polarity symbols marked inside. Replace the cover, securing it with the screw. Place the battery pack close to the latch and slide it in the direction of the arrow until it stops. When using a 6V rechargeable battery pack, place the battery pack in the compartment according to the polarity symbols (+ and -) marked inside. Close the latch, and push the battery pack forward until it stops.
4. Use a coin to turn the battery compartment's latch opposite from the arrow until it stops.

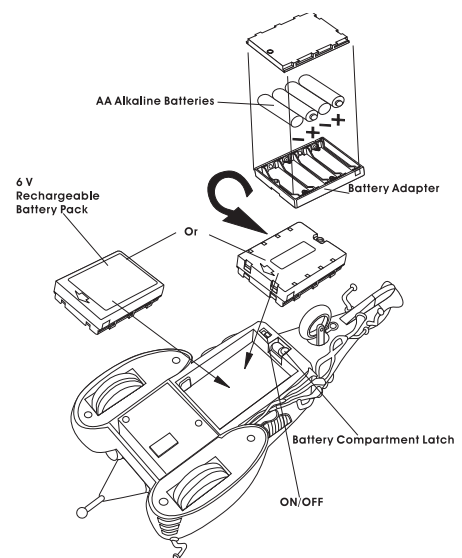

Replacing the Vehicle Battery Pack

1. Use a coin to turn the battery compartment latch in the direction of the arrow to open it.
2. Slide the battery pack towards the latch and lift it to replace it with a new one.

Step Three

Driving the Vehicle

1. Slide **ON/OFF** on the vehicle and transmitter to **ON**. The transmitter's LED lights and the vehicle's headlights illuminate.
2. Use the transmitter's control levers to control the vehicle.

Left Control Lever

- Push forward to move forward.
- Release to stop.
- Pull back to reverse.

HORN — Press to sound the horn.

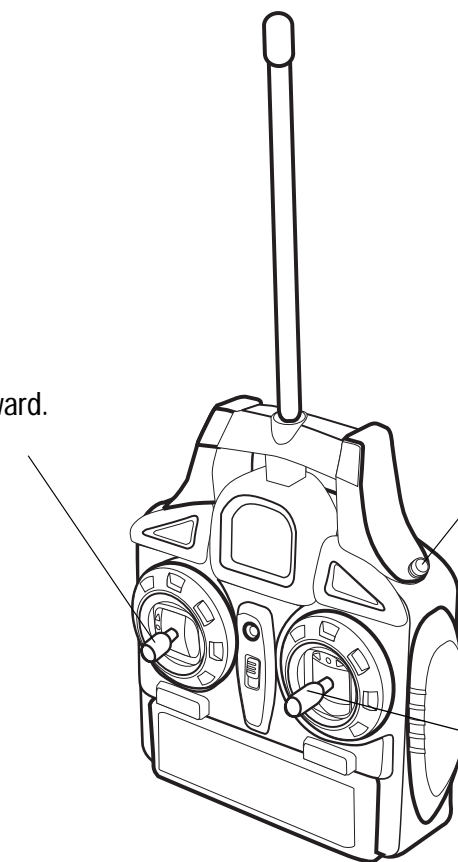

Right Control Lever

- Push left to move left.
- Release to go straight.
- Push right to move right.

3. When you finish driving the vehicle, slide **ON/OFF** on the vehicle and the transmitter to **OFF**.

Wheel Alignment

If the vehicle does not drive in a straight line when you release the right control lever, adjust the wheel alignment control on the bottom of the vehicle. Turn the control toward **L** (left) if the vehicle is pulling to the right or **R** (right) if the vehicle is pulling to the left.

Battery Notes

- Batteries purchased for use in this toy may pose a hazard to children. Please check the safety notice supplied with the batteries before use.
- Before using the battery pack, you must charge it using a special battery charger (not supplied, available at your local RadioShack store). Follow the charger's instructions to charge the battery pack. You can install and drive the car using alkaline batteries while the battery pack is charging.
- If the vehicle runs slowly, not at all, or does not respond to the transmitter, recharge the battery pack, or replace the AA batteries.
- Do not charge or recharge the battery pack while it is in the vehicle.
- After you charge or recharge the battery pack, disconnect it from the charger. Overcharging the battery pack could damage it.
- If you use alkaline batteries to power the motor, they will get very hot. Be sure to wait a few minutes after you stop using the vehicle before you remove the batteries.
- Using alkaline batteries slightly decreases your vehicle's speed.
- Dispose of old batteries promptly and properly.
- Do not burn or bury batteries.
- Use only fresh batteries of the required size and recommended type.
- Do not mix old and new batteries, different types of batteries (standard, alkaline, or rechargeable), or rechargeable batteries of different capacities.
- If you do not plan to use the vehicle for a week or more, remove the batteries. Batteries can leak chemicals that can damage electronic parts.

Helpful Hints

- Running your vehicle continuously for long periods of time generates high heat levels. Heat causes wear and tear on the motor. To keep heat levels down, let the vehicle cool at least 10 minutes before installing a new or newly charged battery pack.
- If the vehicle's motor runs but it does not respond to the transmitter, move closer to the vehicle and try again.
- If someone uses a CB nearby, it might interfere with control of the vehicle. If this happens, move the vehicle away from the CB.
- You cannot operate your vehicle near devices with transmitters that use the same frequency as your vehicle (27 MHz or 49 MHz). Check your vehicle's box to see which frequency your vehicle uses.
- If the vehicle moves slowly and you just installed a fully charged battery pack, check the wheel mechanisms for lint, thread, hair, or dust.
- Do not drive the vehicle in puddles, on a wet floor, on sand, in mud, rain, or snow. This can damage the vehicle.
- If the vehicle gets stuck under an object, immediately release the control levers and retrieve the vehicle.

FCC Information

FCC Declaration of Conformity

This device complies with Part 15 of the *FCC Rules*. Operation is subject to the following two conditions: (1) this device may not cause harmful interference, and (2) this device must accept any interference received, including interference that may cause undesired operation.

Product:	Dr. Seuss' The Cat in the Hat S.L.O.W. Vehicle
Model:	60-4349
Responsible Party:	RadioShack 100 Throckmorton Fort Worth, TX 76102
Phone:	817-415-3200



The FCC Wants You to Know

This equipment has been tested and found to comply with the limits for a Class B digital device, pursuant to Part 15 of the *FCC Rules*. These limits are designed to provide reasonable protection against harmful interference in a residential installation. This equipment generates, uses and can radiate radio frequency energy and, if not installed and used in accordance with the instructions, may cause harmful interference to radio communications.

However, there is no guarantee that interference will not occur in a particular installation. If this equipment does cause harmful interference to radio or television reception, which can be determined by turning the equipment off and on, the user is encouraged to try to correct the interference by one or more of the following measures:

- Reorient or relocate the receiving antenna.
- Increase the separation between the equipment and receiver.
- Connect the equipment into an outlet on a circuit different from that to which the receiver is connected.
- Consult your local RadioShack store or an experienced radio/TV technician for help.
- If you cannot eliminate the interference, the FCC requires that you stop using your vehicle.

Changes or modifications not expressly approved by RadioShack may cause interference and void the user's authority to operate the equipment.

Care

Keep the vehicle dry; if it gets wet, wipe it dry immediately. Use and store the vehicle only in room temperature environments. Handle the vehicle carefully; do not drop it. Keep the vehicle away from dust and dirt, and wipe it with a damp cloth occasionally to keep it looking new.

If your vehicle is not performing as it should, take it to your local RadioShack store for assistance. To locate your nearest RadioShack, use the store locator feature on RadioShack's website (www.radioshack.com), or call 1-800-The Shack (843-7422) and follow the menu options.

Modifying or tampering with the vehicle's internal components can cause a malfunction and might invalidate its warranty and void your FCC authorization to operate it.

Limited 90-Day Warranty

This product is warranted by RadioShack against manufacturing defects in material and workmanship under normal use for ninety (90) days from the date of purchase from RadioShack company-owned stores and authorized RadioShack franchisees and dealers. EXCEPT AS PROVIDED HEREIN, RadioShack MAKES NO EXPRESS WARRANTIES AND ANY IMPLIED WARRANTIES, INCLUDING THOSE OF MERCHANTABILITY AND FITNESS FOR A PARTICULAR PURPOSE, ARE LIMITED IN DURATION TO THE DURATION OF THE WRITTEN LIMITED WARRANTIES CONTAINED HEREIN. EXCEPT AS PROVIDED HEREIN, RadioShack SHALL HAVE NO LIABILITY OR RESPONSIBILITY TO CUSTOMER OR ANY OTHER PERSON OR ENTITY WITH RESPECT TO ANY LIABILITY, LOSS OR DAMAGE CAUSED DIRECTLY OR INDIRECTLY BY USE OR PERFORMANCE OF THE PRODUCT OR ARISING OUT OF ANY BREACH OF THIS WARRANTY, INCLUDING, BUT NOT LIMITED TO, ANY DAMAGES RESULTING FROM INCONVENIENCE, LOSS OF TIME, DATA, PROPERTY, REVENUE, OR PROFIT OR ANY INDIRECT, SPECIAL, INCIDENTAL, OR CONSEQUENTIAL DAMAGES, EVEN IF RadioShack HAS BEEN ADVISED OF THE POSSIBILITY OF SUCH DAMAGES.

Some states do not allow limitations on how long an implied warranty lasts or the exclusion or limitation of incidental or consequential damages, so the above limitations or exclusions may not apply to you.

In the event of a product defect during the warranty period, take the product and the RadioShack sales receipt as proof of purchase date to any RadioShack store. RadioShack will, at its option, unless otherwise provided by law: (a) correct the defect by product repair without charge for parts and labor; (b) replace the product with one of the same or similar design; or (c) refund the purchase price. All replaced parts and products, and products on which a refund is made, become the property of RadioShack. New or reconditioned parts and products may be used in the performance of warranty service. Repaired or replaced parts and products are warranted for the remainder of the original warranty period. You will be charged for repair or replacement of the product made after the expiration of the warranty period.

This warranty does not cover: (a) damage or failure caused by or attributable to acts of God, abuse, accident, misuse, improper or abnormal usage, failure to follow instructions, improper installation or maintenance, alteration, lightning or other incidence of excess voltage or current; (b) any repairs other than those provided by a RadioShack Authorized Service Facility; (c) consumables such as fuses or batteries; (d) cosmetic damage; (e) transportation, shipping or insurance costs; or (f) costs of product removal, installation, set-up service adjustment or reinstallation.

This warranty gives you specific legal rights, and you may also have other rights which vary from state to state

RadioShack Customer Relations, 200 Taylor Street, 6th Floor, Fort Worth, TX 76102

12/99