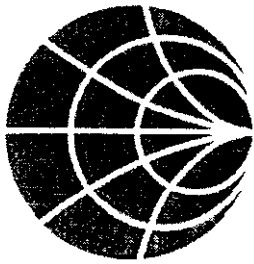



**EXHIBIT 8**  
OWNER'S MANUAL



# **RadioConnect**

**C O R P O R A T I O N**

*"Wireless That Works"*

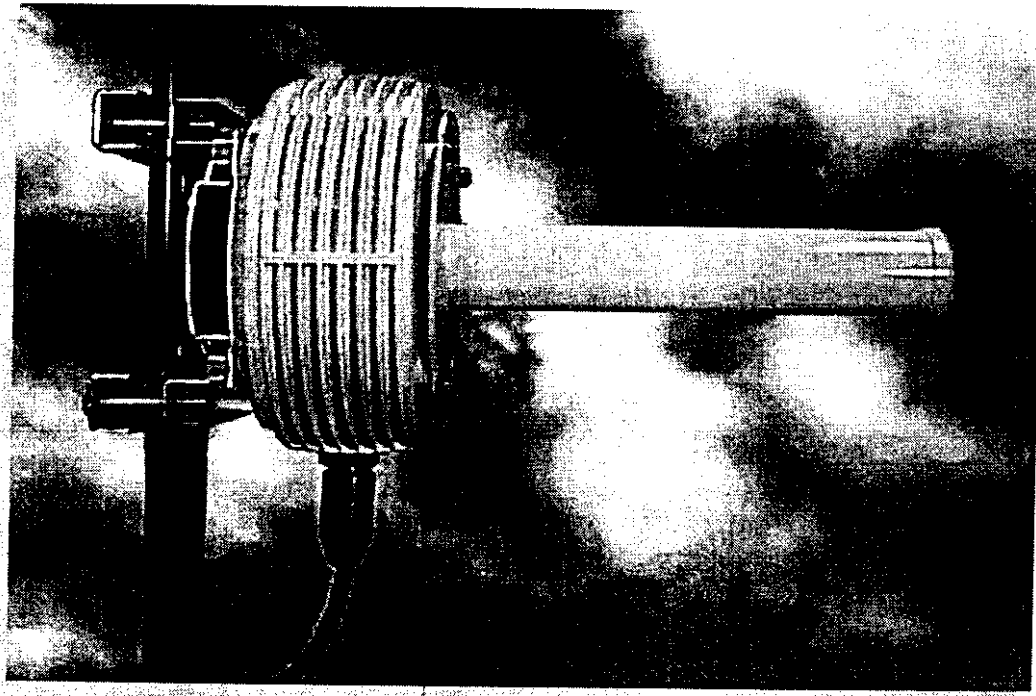

**Including:**

- ◆ System Description
- ◆ Installation
- ◆ Operation
- ◆ Troubleshooting

## **RadioWire<sup>®</sup>**

*Wireless Internet Service Link*

## **User's Manual**

FCC ID: NFX-RCC0001-00



***RadioConnect***  
**C O R P O R A T I O N**

*"Wireless That Works"*

**RadioWire<sup>®</sup>**

*Wireless Internet Service Link*

**User's Manual**

RadioConnect Corporation

6041 Bristol Parkway  
Culver City, CA 90230

Tel: (310) 338-3388

Fax: (310) 338-3399

Internet: <http://www.radioconnect.com/>

P/N 950-0002-00

Rev. A      04/98

FCC ID: NFX-RCC0001-00

## **All Rights Reserved**

Copyright 1998 RadioConnect Corporation, World Rights Reserved

RadioConnect Corporation provides this document "as is," without warranty of any kind, either expressed or implied, including, but not limited to the implied warranties of merchantability and fitness for a particular purpose. RadioConnect Corporation may make changes and improvements to the product described in this manual at any time and without notice. RadioConnect Corporation assumes no responsibility for its use, nor any infringements of patents or other rights of third parties that would result.

This document could contain technical inaccuracies or typographical errors. Periodic changes are made to the information contained herein. These changes will be incorporated into new editions of the manual.

## **Disclaimers**

### Product Compatibility

Although many different communications products and networks have been tested with this product, RadioConnect makes no claim of compatibility between its products and other vendor's equipment. The user has the responsibility to thoroughly evaluate this product's performance in his/her communications environment.

### Safety

General safety precautions must be followed during all aspects of the operation of this product. Failure to follow these precautions or specific warnings in this manual willfully violates integrity of the design, manufacture, and intended use of the product. RadioConnect Corporation assumes no liability for the customer's failure to comply with these requirements.

The product must be grounded. An ungrounded unit poses an unnecessary electrical shock risk.

There are no user maintainable or adjustable components inside this product. The cover should not be removed by anyone other than authorized RadioConnect service personnel.

Installing substitute parts or performing any unauthorized modifications to the Wireless Internet Service Link (WISL) constitutes a violation of the warranty. If the product needs repair, contact the Customer Service Department at RadioConnect to obtain a Return Material Authorization (RMA) number before returning the unit.

### Tower Construction

Local zoning and tower construction regulations must be followed when installing the WISL unit. Commonly, permits must be obtained before tower installation begins. For additional information, check with your local zoning and aviation authorities.

### Exportability

Wireless Internet Service Link products are subject to the export and re-export regulations of the U.S. government. No WISL product may be exported or re-exported in violation of the applicable regulations. Contact RadioConnect Corporation for further information about export regulations.

### Criticality

The Wireless Internet Service Link is not intended for life-critical situations, or as a critical component in a life support system or device.

## FCC ID: NFX-RCC0001-00

### Trademark Acknowledgments

RadioWire and RadioConnect are registered trademarks of RadioConnect Corporation. Wireless Internet Service Link and WISL are trademarks of RadioConnect Corporation. All other product names mentioned herein are used for identification purposes only, and may be the trademarks or registered trademarks of their respective companies.

### Regulatory Approvals

All components used in the Wireless Internet Service Link are certified to meet the following specifications:

FCC: Part15, Subpart J, Class B

UL Declaration of Conformity

### FCC Statement

This equipment has been tested and found to comply with the limits for a Class B digital device, pursuant to part 15 of the FCC Rules. These limits are designed to provide reasonable protection against harmful interference in a residential installation. This equipment generates, uses and can radiate radio frequency energy and if not installed and used in accordance with the instructions, may cause harmful interference to radio communications. However, there is no guarantee that interference will not occur in a particular installation. If this equipment does cause harmful interference to radio or television reception, which can be determined by turning the equipment off and on, the user is encouraged to try to correct the interference by one or more of the following measures:

- Reorient or relocate the receiving antenna.
- Increase the separation between the equipment and receiver.
- Connect the equipment into an outlet on a circuit different from that to which the receiver is connected.
- Consult the dealer or an experienced radio/TV technician for help.

This equipment has been certified to comply with the limits for a class B computing device pursuant to FCC Rules. In order to maintain compliance with FCC regulations, shielded cables must be used with this equipment. Operation with non-approved equipment or unshielded cables is likely to result in interference to radio and TV reception. The user is cautioned that changes and modifications made to the equipment without the approval of the manufacturer could void the user's authority to operate this equipment.

## Table of Contents

<i>All Rights Reserved</i> .....	<i>i</i>
<i>Disclaimers</i> .....	<i>i</i>
<i>Trademark Acknowledgments</i> .....	<i>ii</i>
<i>Regulatory Approvals</i> .....	<i>ii</i>
<i>FCC Statement</i> .....	<i>ii</i>
<b>PREFACE</b> .....	<b>V</b>
READER RESPONSE.....	V
<b>1 INTRODUCTION</b> .....	<b>1-1</b>
1.1 WIRELESS INTERNET SERVICE LINK (WISL) FEATURES.....	1-1
1.2 UNPACKING YOUR SYSTEM.....	1-2
<b>2 SYSTEM DESCRIPTION</b> .....	<b>2-1</b>
2.1 RADIOWIRE MODEM.....	2-1
2.1.1 <i>Alignment Indicators</i> .....	2-1
2.1.2 <i>Antenna</i> .....	2-2
2.1.3 <i>Mounting Bracket</i> .....	2-2
2.1.4 <i>RWM-to-NIM Cable</i> .....	2-2
2.2 NETWORK INTERFACE MODULE.....	2-6
2.2.1 <i>Rear Panel Connectors</i> .....	2-6
2.2.2 <i>Front Panel Display and Indicators</i> .....	2-7
2.2.3 <i>Synchronization Cable</i> .....	2-8
<b>3 INSTALLATION</b> .....	<b>3-1</b>
3.1 SYSTEM INSTALLATION KIT.....	3-1
3.2 INSTALLATION PROCEDURE.....	3-1
3.3 CONFIGURING YOUR SYSTEM.....	3-3
3.4 CONFIGURATION COMMANDS.....	3-3
3.4.1 <i>Pseudo-Random Spreading Code</i> .....	3-4
3.4.2 <i>Frequency Channel</i> .....	3-4
3.4.3 <i>Master/Slave Status</i> .....	3-4
3.4.4 <i>Synchronization Generator Status</i> .....	3-6
3.4.5 <i>Transmit Power Control Mode and Level</i> .....	3-6
3.4.6 <i>(NIM-related commands)</i> .....	3-6
3.5 PRE-INSTALLATION TESTING.....	3-9
3.5.1 <i>Troubleshooting</i> .....	3-9
3.6 INSTALLING THE RADIOWIRE MODEM.....	3-10
3.6.1 <i>Attaching the RWM and Antenna to the Pole</i> .....	3-10
3.6.2 <i>Cable Installation</i> .....	3-13
3.7 INSTALLING THE NETWORK INTERFACE MODULE.....	3-14
3.7.1 <i>Electrical Requirements</i> .....	3-15
3.8 ANTENNA ALIGNMENT PROCEDURE.....	3-15
3.9 CONNECTING TO USER'S EQUIPMENT.....	3-15
<b>4 OPERATION</b> .....	<b>4-1</b>
4.1 OPERATING COMMANDS.....	4-1
4.2 TROUBLESHOOTING.....	4-1
4.3 CUSTOMER SUPPORT.....	4-2

**APPENDIX A    TECHNICAL SPECIFICATIONS - RADIOWIRE MODEM .....A-1**

**APPENDIX B    TECHNICAL SPECIFICATIONS - WISL NETWORK INTERFACE MODULE .... B-1**

**APPENDIX C    LINK CONFIGURATION WORKSHEET ..... C-1**

**APPENDIX D    NETWORK INTERFACE SPECIFICATION (SERIAL)..... D-1**

**APPENDIX E    NETWORK INTERFACE SPECIFICATION (ETHERNET) .....E-1**

**APPENDIX F    RWM-TO-NIM CABLE SPECIFICATION ..... F-1**

**FCC ID: NFX-RCC0001-00**

**Preface**

*This manual is intended for use by installers, operators and system administrators who install, configure or operate Wireless Internet Service Links (WISLs). Each end of a RadioConnect wireless link consists of a RadioWire Modem (RWM) and a Network Interface Module (NIM). General guidelines for installation preparations are covered in this manual. If you do not have a working knowledge of data communications, telecommunications, and radio frequency equipment, or if you are uncomfortable with any facet of installing radio communications equipment, including all electrical regulations and safety practices that apply to the installation site, contact a qualified installer. If you need assistance locating a qualified installer, contact RCC's customer service department at (310) 338-3388.*

**Reader Response**

We at RadioConnect encourage you to respond to our products and documentation. Submit your comments, suggestions, and ideas to improve our product to:

RadioConnect Corporation  
6041 Bristol Parkway  
Culver City, CA 90230, U.S.A.

Tel: (310) 338-3388  
Fax: (310) 338-3399  
Internet: <http://www.radioconnect.com>  
E-mail: [info@radioconnect.com](mailto:info@radioconnect.com)



**FCC ID: NFX-RCC0001-00****1 Introduction**

This manual is intended for use by installers, network engineers, network administrators or other individuals who have the responsibility for installing, configuring and operating RadioConnect® Wireless Internet Service Link (WISL) systems. It provides unpacking instructions, a detailed description of system components, configuration and installation procedures, as well as operating and troubleshooting guidelines.

The manual assumes that link Configuration Worksheets are available that were previously prepared under the guidelines provided in the:

- RadioWire® System Overview and Planning Manual (P/N 950-0001-00)

If Configuration Worksheet(s) have not been prepared, we strongly recommend that you do so before proceeding.

**1.1 Wireless Internet Service Link (WISL) Features**

Your RadioConnect WISL systems offer the following features and capabilities:

- Spread-spectrum operation in the 2.4000 - 2.4835 GHz (S-Band) frequency range.
- 256 kbps full-duplex user-data throughput.
- Up to 20-mile (32-km) range.
- Three different antenna choices depending on range and path requirements.
- Patented direct sequence encoding, with a code sequence length of 32,768 chips.
- More than 16,000 unique software-selectable pseudo-random spreading codes.
- Patented end-to-end synchronization over the airwaves, for 'coherent' networking.
- Circularly polarized antennas, for substantial attenuation of multipath interference.
- Automatic error correction across the link, transparent to the user's protocol.
- Maximum cold-start signal acquisition time of 10.5 sec. each way.
- Built-in signal quality and signal strength indicators, for antenna alignment.
- Small and lightweight.
- No antenna feedline – so no feedline loss.
- Diverse interfaces available for connection to user equipment.
- Master transmit synchronization among co-located units.
- Five selectable channels within the operating band (three non-overlapping).
- Repeater capability for expanded coverage.
- Remote test capabilities.

**FCC ID: NFX-RCC0001-00****1.2 Unpacking Your System**

Carefully inspect the packages containing your new system as soon as they arrive. Make sure there are no signs of poor handling or abuse. Look for damaged corners, holes or wrinkles in the packaging. All of the equipment was carefully inspected before leaving RCC. Report any shipping damage immediately to the delivery company.

Verify that you received the following items, which are illustrated in Figure 1-1 (with the exception of the floppy disk and manual):

- RadioWire Modem (RWM)
- Pole mounting bracket
- Antenna - one of the three different models shown, as ordered
- RWM-to-NIM cable - length as specified in your order
- Network Interface Module (NIM)
- NIM-to-NIM synchronization cable
- AC power cord
- Configuration software on floppy disk
- User's Manual

If any items are missing, please contact the reseller from whom you purchased the system, and notify them of the discrepancy.

RadioWire Modem

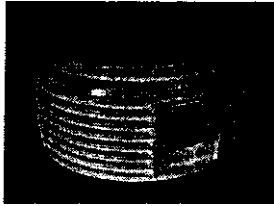

Pole mounting bracket



+14dBi gain antenna

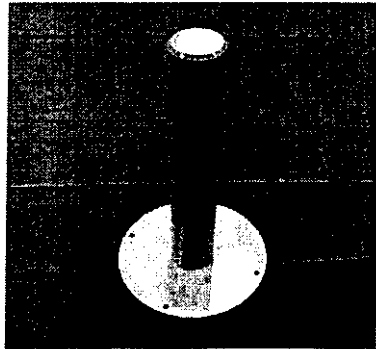

+20dBi gain antenna

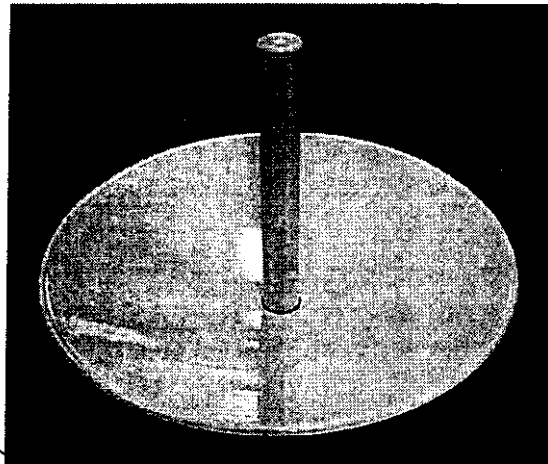

+24dBi gain antenna

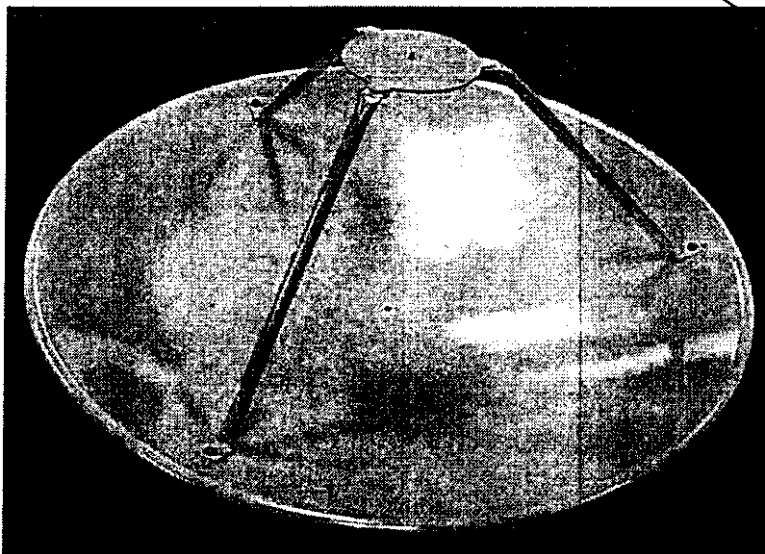

Three optional antennas

RWM-to-NIM cable



Sync cable, NIM, and power cord

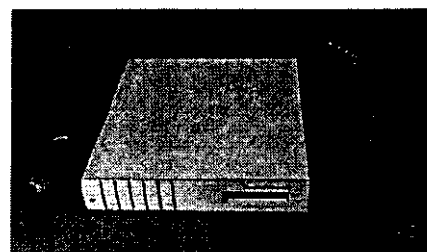

**Figure 1-1. WISL System Hardware Components**

FCC ID: NFX-RCC0001-00

## 2 System Description

### 2.1 RadioWire Modem

The RadioWire Modem is housed in a cast aluminum casing designed to withstand severe weather conditions. It contains no parts that require user access, and should not be opened by anyone except RadioConnect's authorized service personnel.

#### 2.1.1 Alignment Indicators

Two alignment indicators are inset into the underside of the RWM case for ease of viewing from a distance and in bright sunlight. These indicators are light emitting diodes (LEDs) - one green, and one red:

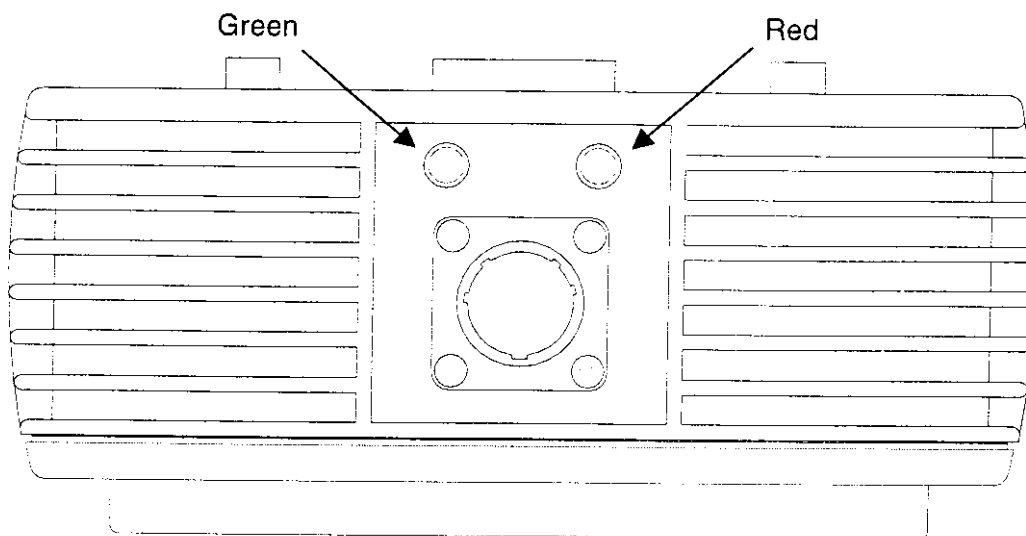

Figure 2-1. Alignment Indicator LEDs

The indicator lights have the following functions:

Green = Signal Quality/Power:

Flashes at 0.5 Hz rate, 25% duty cycle, when power is present but no correlation.

Flashes at 2 Hz rate, 25% duty cycle, when signal is detected.

Duty cycle ('on' state) increases as signal quality improves. Duty cycle reaches 100% (i.e. the LED is on continuously) when the received signal achieves a 20 dB margin level above the  $10^{-6}$  BER receiver sensitivity level.

Red = Packet error:

Indicates the occurrence of a link level error.

Duty cycle varies from 0% to 100% depending on re-transmission rate.

## FCC ID: NFX-RCC0001-00

**2.1.2 Antenna**

Figures 2-3 through 2-5 provide details of the three antenna types available with the RWM. It is not necessary to use the same type of antenna at the two ends of a link. The actual combination depends on the range required. Table 2-1 shows the range capabilities of each possible combination in free space conditions, assuming that a link margin of at least 25 dB is pre-requisite. Note that the upper limit of 20 miles is governed by protocol constraints, and not by the antenna gain.

	<b>Helical</b>	<b>0.6m dish</b>	<b>1.0m dish</b>
<b>Helical</b>	Range: 5 miles (8 km) Link margin: 25.7 dB		
<b>0.6m dish</b>	Range: 10 miles (16 km) Link margin: 25.7 dB	Range: 20 miles (32 km) Link margin: 25.7 dB	
<b>1.0m dish</b>	Range: 16 miles (26 km) Link margin: 25.5 dB	Range: 20 miles (32 km) Link margin: 29.7 dB	Range: 20 miles (32 km) Link margin: 33.7 dB

**Table 2-1. Range and Link Margin with Different Antenna Combinations**

**2.1.3 Mounting Bracket**

RadioConnect antenna mounting brackets are designed to allow tilting in the vertical plane, to accommodate elevation differences between the RWM units at the two ends of a link. This capability is especially useful for relatively short links. The brackets are calibrated with tilt angles above and below horizontal. Once the RadioWire Modems have been installed and aligned with each other, and the brackets firmly locked in their optimum positions, you should record the tilt angles read from the mounting brackets, in your Configuration Worksheet.

**2.1.4 RWM-to-NIM Cable**

The cable that runs between the roof-mounted RWM and the in-building NIM is a special serial cable that carries low voltage power up to the RWM, as well as carrying data between the units. This cable is offered in standard lengths from 25 feet to 200 feet, and in two different fire-resistance ratings - standard or plenum-rated. Custom lengths are also available to special order. Check that the lengths of the cables you receive match your order, and if there is any discrepancy, notify your reseller as soon as possible.

The standard PVC cable is satisfactory for use in vertical wall cavities and shafts, while plenum-rated cable is required for routing through under-floor plenum space. In either case, the cable is supplied as a kit, with the connector not installed at one end in order to facilitate feeding the cable between the RWM and NIM. The connector for attachment to the RWM is molded on to the cable, while the DB-25 for attachment to the NIM is not installed. Instead, the open end of the cable has a sleeve on it, as shown in Figure 2-2.

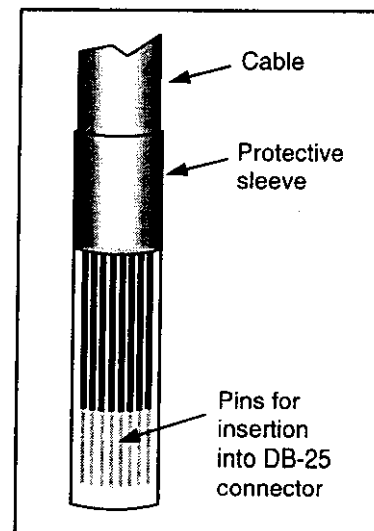

**Figure 2-2. NIM End of Cable, as Shipped.**

FCC ID: NFX-RCC0001-00

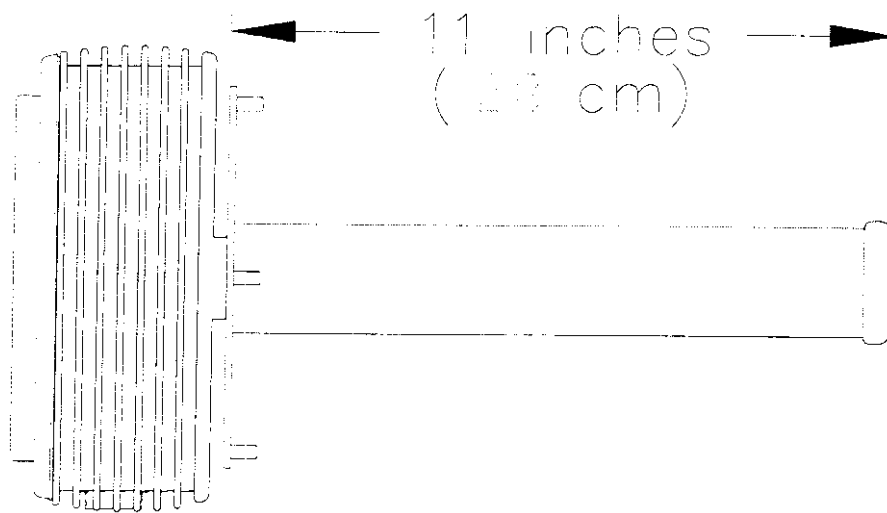
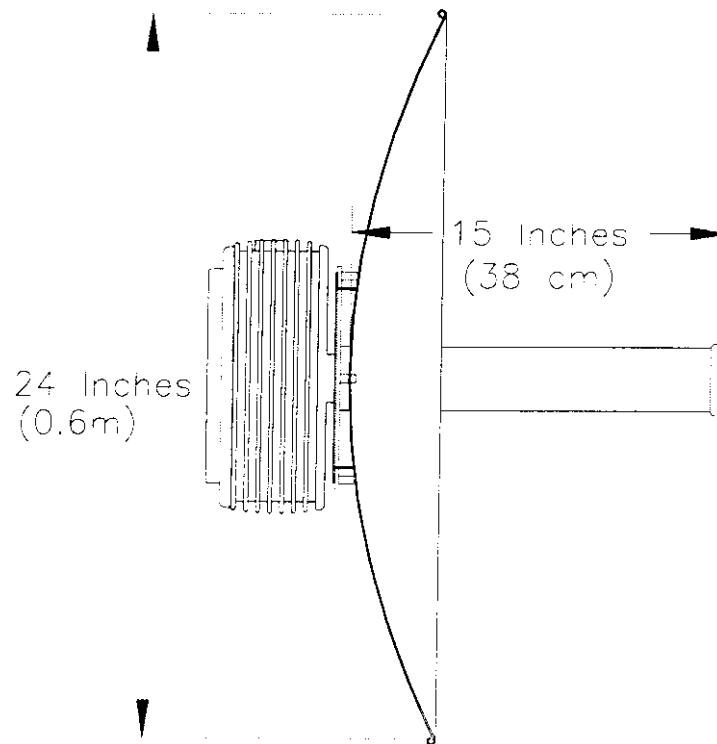

Figure 2-3. Helical Antenna

Dimensions:	Approx. 2.1 in [5.3 cm] diameter, 11 in [27.9 cm] length	
Weight:	Less than 4.5 lbs. [2 kg.] (Antenna Only)	
Electrical Characteristics:	50 ohm; 1:1.3 VSWR	
Gain pattern:	14 dBi, 35-degree beam width, right-hand or left-hand circularly polarized.	
Wind Survivability:	125 mph [200 km/h]	
Wind Load:	0.4 sq. ft. [0.04 sq. m]	
Part Numbers:	Right-hand polarization (White Cap)	250-0001-00
	Left-hand polarization (Blue Cap)	250-0001-01

**FCC ID: NFX-RCC0001-00****Figure 2-4. 0.6 Meter Dish Antenna**

Dimensions:	Approx. 24 in [61 cm] diameter, 15 in [38.1 cm] length	
Weight:	Less than 13.5 lbs. [6 kg.]	
Electrical Characteristics:	50 ohm; 1:1.3 VSWR	
Gain pattern:	20 dBi, 15-degree beam width, right-hand or left-hand circularly polarized.	
Wind Survivability:	125 mph [200 km/h]	
Wind Load:	3.3 sq. ft. [0.3 sq. m]	
Part Numbers:	Right-hand polarization (White Cap)	250-0002-00
	Left-hand polarization (Blue Cap)	250-0002-01

## 2.2 Network Interface Module

FCC ID: NFX-RCC0001-00

The Network Interface Module (NIM) provides the connection point between user equipment and the WISL system. It may be installed as a stand-alone unit, or pairs of NIM units may be coupled together side-by-side and mounted in a standard 19" rack. RadioConnect offers a custom kit for this purpose (part number 250-0001-00). When installed in a rack, the NIM units occupy 1U height.

### 2.2.1 Rear Panel Connectors

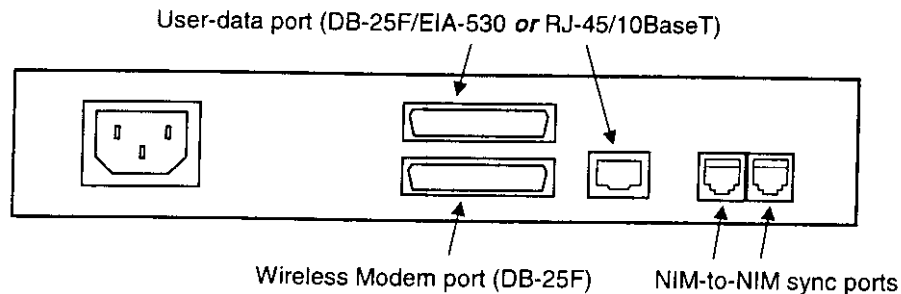

**Figure 2-6. Rear Panel**

The NIM rear panel is illustrated in Figure 2-6. The following connectors are present on both models of the NIM (serial or Ethernet):

- AC Power: Standard IEC male connector.  
90-264 VAC (auto-sensing), 47-63 Hz
- RWM port: DB-25 female connector, for attachment of RWM-to-NIM cable. See Appendix F for signals and pinouts.
- NIM-to-NIM ports: RJ-H connectors, for synchronization among multiple co-located NIM units.

For the WISL system with serial interface, there is an additional connector for the:

- Serial port: DB-25 female, for attachment to user equipment. See Appendix D for EIA-530 signals and pinouts. For connection to Cisco routers in the following families, use Cisco cable CAB-530MT (part number 72-0797-01): Cisco 7000 series, 4000 series, 3600 series, 2500 series, 1600 series, Cisco access servers, and AccessPro cards.

For the WISL system with Ethernet interface, there is an additional connector for the:

- Ethernet port: RJ-45, for attachment to user's 10BaseT LAN.



## 2.2.2 Front Panel Display and Indicators

FCC ID: NFX-RCC0001-00

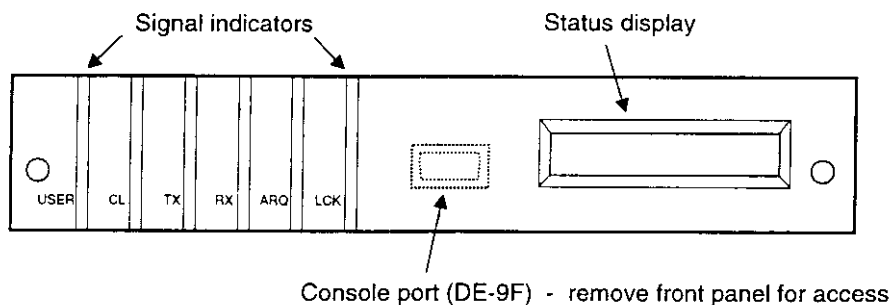

Figure 2-7. Front Panel

Figure 2-7 shows the NIM front panel layout. The liquid crystal display (LCD) at the right side of the panel displays ongoing status information, as selected by the user during setup. The status information is updated automatically at 30-second intervals.

At the left side of the panel, six light emitting diodes (LEDs) serve as signal indicators:

- **USER**  
(Green LED) An active connection exists between the NIM and the user's equipment. For the serial NIM, this implies that the cable between the NIM and the user's equipment is installed, and that the DTR (Data Terminal Ready) signal is asserted. For the Ethernet NIM, the LED indicates that an active Ethernet cable is connected to the NIM.
- **CL**  
(Red LED) For the serial NIM, this LED indicates that the NIM clocking signal is present. This is the signal that enables synchronous transmission to occur. For the Ethernet NIM, this LED flashes whenever a collision is detected.
- **TX**  
(Yellow) This LED is on whenever the user's equipment is transmitting data to the NIM.
- **RX**  
(Yellow) This LED is on whenever the NIM is forwarding the data it has received from the RWM, to the user's equipment.
- **ARQ**  
(Red) The ARQ LED flashes at the receiving end of a link when a packet error is detected.
- **LCK**  
(Red/Green) This LED has a dual function. It flashes red while the RadioWire modems at the two ends of the link are attempting to synchronize with one another. Once synchronized, the LED changes to a solid green display, indicating that the two ends are locked.

For initial configuration or re-configuration of the WISL system, the front panel of the NIM unit may be removed to provide access to the Console port. The port comprises a female DE-9 connector, to which either a PC-compatible computer or a dumb terminal may be attached. The cable required is a 9-pin straight-through male-to-female serial cable. A 6-foot cable of this type is included in the System Installation Kit available separately from RadioConnect (part number 004-0001-00). Such cables are also readily available at most computer stores.

FCC ID: NFX-RCC0001-00

## 3 Installation

### CAUTION

If you are not familiar with working on towers and antennas, get help from an experienced installer. Installing tower structures and mounting antennas can be dangerous and life threatening. Make sure the tower or pole you are using is of appropriate size to carry the weight and wind load of the RadioWire Modem and antenna system.

### 3.1 System Installation Kit

RadioConnect offers a System Installation Kit (part number 004-0001-00) which may be purchased separately from your WISL systems. Although not pre-requisite for installing a link, the kit is recommended. It is re-usable for installing multiple links, and contains the following items:

- 3-foot RWM-to-NIM cable, required if units are to be configured prior to installation
- 6-foot Console cable
- RF emulation cable
- Cable pull grip
- Cable assembly/continuity tester for RWM-to-NIM cable (comprises 2 components – loop-back terminator for RWM end of cable, and display terminator for NIM end.)
- Tools: Allen key, screwdriver and wrench
- Magnetic compass

In addition to these items, the person installing the link may also need a steel-tape cable puller (also referred to as a "snake"), and some nylon cable ties. A cable tie will be used to attach the cable pull grip to the cable puller, as explained in Section 3.6.1 below.

### 3.2 Installation Procedure

Figure 3-1 shows a high level flowchart of the required and optional steps for installing a link. The WISL equipment can be installed without requiring initial configuration. However, this is not recommended, as it is much easier to configure and test both units together at a single location, before they are transferred to their eventual (remote) sites.

In either case, at least one configuration parameter *must* be set before the two WISL systems can communicate. That parameter is the 'Master/Slave Status' (Section 3.4.3). Until one end of the link is set as Master, and the other end as Slave, installed units cannot be aligned.

FCC ID: NFX-RCC0001-00

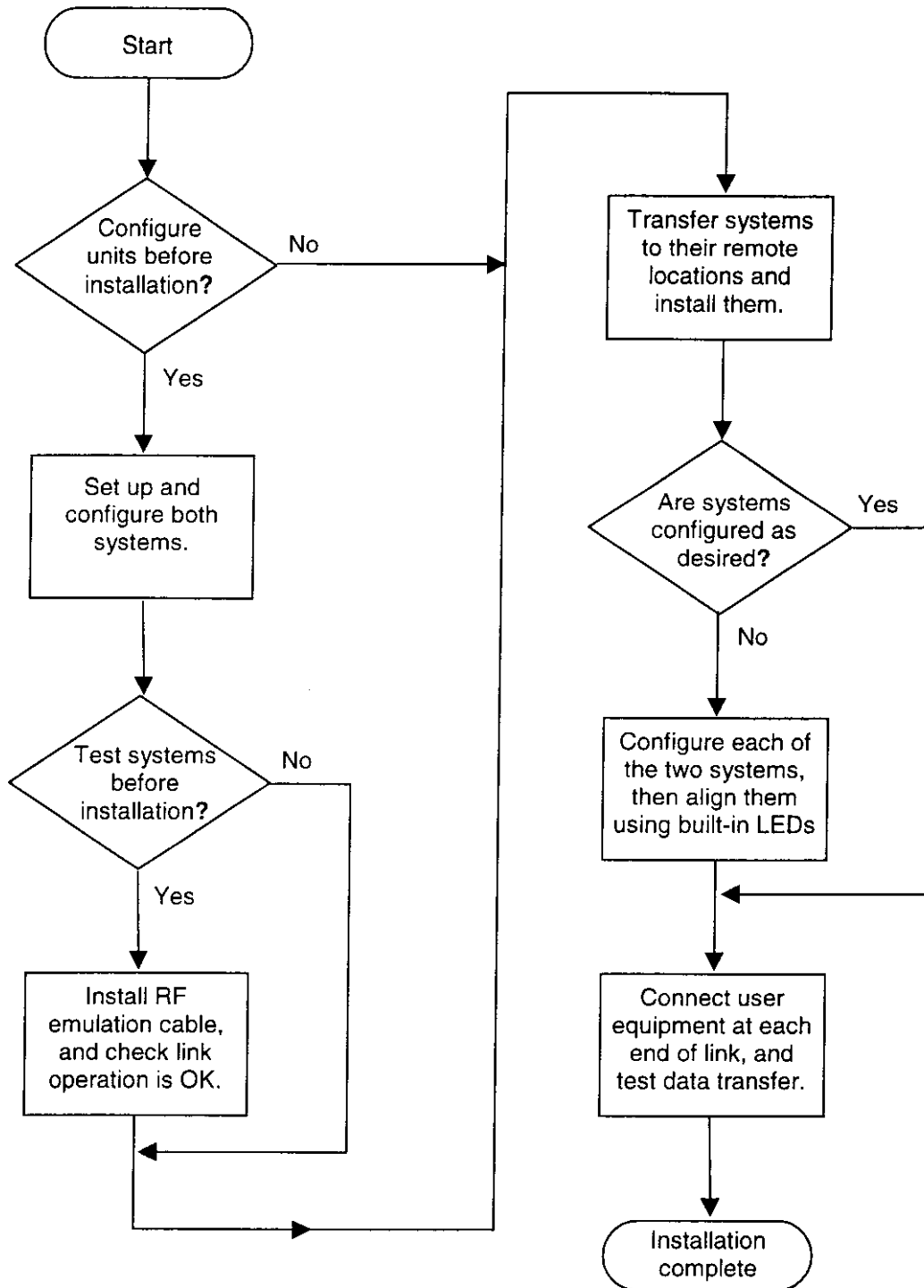

Figure 3-1. Installation Procedure

FCC ID: NFX-RCC0001-00

### 3.3 Configuring Your System

The first step towards configuring each of your WISL systems is to complete the link Configuration Worksheet (Appendix C). Refer to the System Overview and Planning Manual (part number 950-0001-00) for guidance in preparing the Worksheet. There are several important parameters that must be configured correctly for proper operation:

- 1) Pseudo-random spreading code
- 2) Frequency channel
- 3) Master/Slave status
- 4) Synchronization generator status
- 5) Transmit power control mode and level

Each of these parameters is discussed in detail below, and a completed Worksheet example is shown in Figure 3-6.

Next, take the following steps in preparation for configuring each unit:

- If the configuration process is being carried out before a WISL system has been installed, connect the RWM and NIM together using the 3-foot cable provided in the System Installation Kit.
- If the configuration process is being carried out after installation, the RWM and NIM are already connected.
- Connect a personal computer (PC) to the NIM console port (section 2.2.2) using a standard serial cable (9-pin, straight through, male-to-female). One such cable is provided in the System Installation kit. If no PC is available, an ASCII terminal can be used instead, setting it for operation at 9600bps, no parity, and 1 stop bit.
- Power up both the PC and the NIM, and then load the RadioWire configuration software provided with your WISL system. Simply follow the on-screen instructions to enter the configuration parameter values. If an ASCII terminal is being used, commands are entered as described in the following sections. Valid parameter values are the same, whether a PC or a terminal is being used.

### 3.4 Configuration Commands

If using a terminal for configuring your system, press the <Enter> key (↵), and you should see the messages:

```
RadioConnect Corporation
RadioWire Modem Configuration Program, Ver. 1.0 (C) 1998
Enter command:
>
```

The general format of commands is the following:

```
> XX[n]↵
```

Where **XX** is a two-character command identifier, **n** is a variable-length decimal numeric string, and ↵ is the <Enter> or carriage return key. If **n** is omitted from a command that normally requires a numeric value, the parameter is reset to its default value.

After setting parameters according to your specific installation needs, terminate the configuration process by typing:

```
> exit
```

### 3.4.1 Pseudo-Random Spreading Code

There are more than 16,000 possible pseudo-random spreading codes available to ensure the privacy of RadioWire links, and which contribute towards the extraordinary interference rejection characteristics of RWM units. The same value must be configured for both ends of a link. If multiple links are to be installed, select a different code for each link.

Many RWMs can share the same frequency channel with negligible interference when a different pseudo-random code is selected for each different link.

*Command format:*                      PCn  
Where n = 0 - 16,383                      (default = 0)

### 3.4.2 Frequency Channel

The RadioWire Modem supports three discrete, non-overlapping frequency channels within the 2.4 GHz band allocated for unlicensed use in the U.S.A. These are shown in the Configuration Worksheet as channels 1, 3 and 5. The other two channels (2 and 4) partially overlap their neighbors. In general, use channels 1, 3 or 5 only, unless you are co-locating more than three RWM units at the same site.

*Command format:*                      CHn  
Where n = 1 - 5                              (default = 1)

### 3.4.3 Master/Slave Status

One unit on each point-to-point link must be configured as the link Master. The other unit must be the link Slave. The link Master controls transmit and receive timing for a given link. When multiple RWM units are co-located, they will typically all be specified as Masters (Figure 3-2). However, if a hierarchical network is being built, similar to that shown in Figure 3-3, all nodes except the central one will have at least one Slave coupled to one or more subsidiary Masters through appropriate user equipment such as an Ethernet hub or a serial synchronous time-division multiplexer (TDM).

*Command format:*                      MA              (Master)                      (default)  
    SL              (Slave)

## FCC ID: NFX-RCC0001-00

**3.4.4 Synchronization Generator Status**

When multiple RWMs are co-located at a site, they must be synchronized to all transmit at the same time and all receive at the same time, to help avoid mutual interference. To accomplish this, every RWM is equipped with the ability to generate a synchronous clock signal. However, only one unit can be the active synchronization generator at any given time, and all other co-located units must receive the synchronization signal through the 'daisy-chain' of cables that couple their NIMs together. The RWM that will be the active synchronization generator must be specified as the 'Primary', in the Configuration Worksheet.

In the event of failure of the primary unit, another RWM may be designated to take over the role of synchronization generator. This unit is specified as the 'Secondary'. Similarly, in the event of failure of the Secondary unit, a third unit may be designated to take over. It is specified in the Worksheet as the 'Tertiary'. This is illustrated in Figure 3-4. Note that designation of Secondary and Tertiary synchronization generators are recommended, but not pre-requisite.

A special requirement applies at all subsidiary nodes of a hierarchical network. At all such nodes, only Slave units may take the role of synchronization generators. This is because a Slave unit derives its clock from the airwave signal it receives from its associated Master. In the example shown in Figure 3-5, two links from the central node (using different frequency channels) feed a subsidiary node, and several downlinks emanate from the latter. The two Slaves at the subsidiary node are designated as Primary and Secondary, while the subsidiary Masters must all be configured with their synchronization generator parameters set to 'None'.

*Command format:*

GNn↓

Where: n = 0 means 'None' (default = 0)  
 n = 1 means 'Primary'  
 n = 2 means 'Secondary'  
 n = 3 means 'Tertiary'

**3.4.5 Transmit Power Control Mode and Level**

This parameter may be set to either 'Auto' or 'Manual' mode. Under most circumstances, Auto mode should be specified. However, some countries require a lower transmit power level than the +24dB permitted in the U.S.A. In such cases, specify Manual mode and set the appropriate power level.

*Command format:*

TA↓ (Auto) (default)

TMn↓ (Manual)

Where: n = 0 - 38 for -14dB to +24dB  
 (i.e. n = 0 means -14dB  
 n = 38 means +24dB)

**3.4.6 (NIM-related commands)**

*(To be determined)*

FCC ID: NFX-RCC0001-00

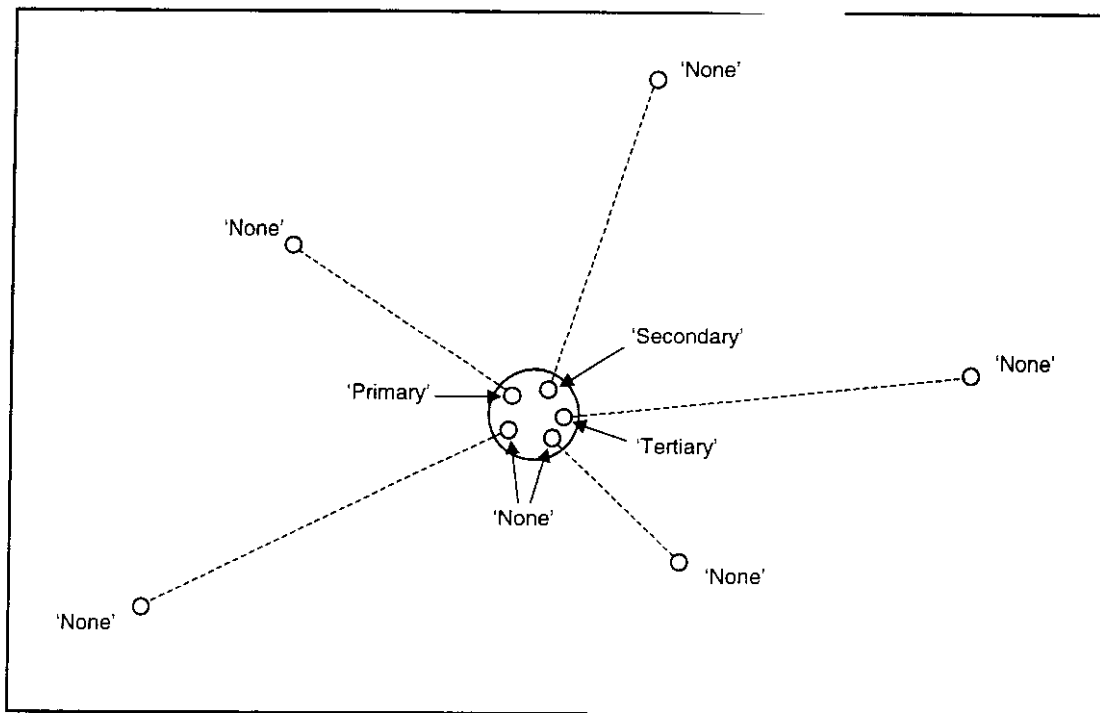

Figure 3-4. Synchronization Generators in a Star Network

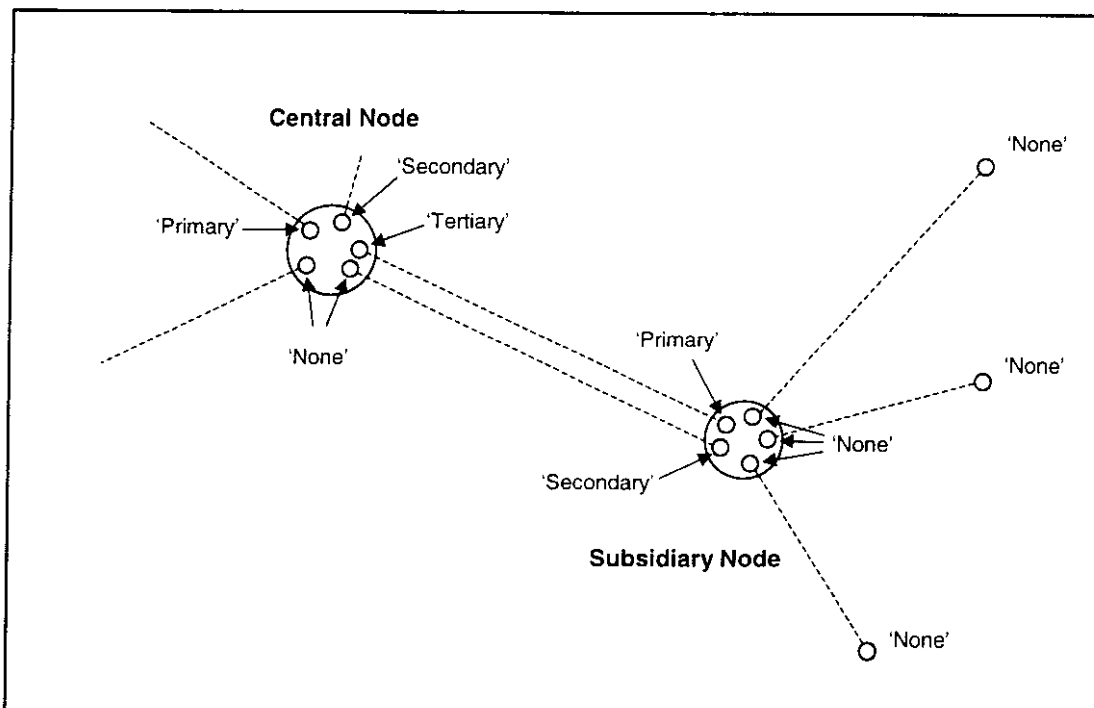

Figure 3-5. Synchronization Generators in a Hierarchical Network

## FCC ID: NFX-RCC0001-00

Location A		Location B	
<b>Name (for ref. only)</b>	Headquarters	<b>Name (for ref. only)</b>	Branch 01
<b>Serial Number</b>	xxxxxxxxx	<b>Serial Number</b>	xxxxxxxxx
<b>Location</b>	Culver City	<b>Location</b>	Long Beach
<b>Latitude</b>	33 deg. 59 min. 10 sec.	<b>Latitude</b>	33 deg. 45 min. 20 sec.
<b>Longitude</b>	118 deg. 23 min. 20 sec.	<b>Longitude</b>	118 deg. 11 min. 40 sec.
<b>Elevation of RWM</b>	93 feet	<b>Elevation of RWM</b>	57 feet
<b>Distance (A to B)</b>	19.43 miles		
<b>Azimuth of Loc. B</b>	144.94 deg.	<b>Azimuth of Loc. A</b>	324.94 deg.
<b>Heading to Loc. B</b>	deg	<b>Heading to Loc. A</b>	deg.
<b>Antenna Type</b> <i>(may be different at the 2 locations)</i>	<input type="checkbox"/> Helical <input checked="" type="checkbox"/> 0.6 m dish <input type="checkbox"/> 1.0 m dish	<b>Antenna Type</b>	<input type="checkbox"/> Helical <input checked="" type="checkbox"/> 0.6 m dish <input type="checkbox"/> 1.0 m dish
<b>Ant. Cap Color</b>	<input checked="" type="checkbox"/> White <input type="checkbox"/> Blue	<b>Ant. Cap Color</b>	Same as location A
<b>Antenna Angle in Vertical Plane</b>	0 deg. (horizontal)	<b>Antenna Angle in Vertical Plane</b>	0 deg. (horizontal)
<b>Pseudo-Random Spreading Code #</b> <i>(0 - 16,383)</i>	17	<b>Pseudo-Random Spreading Code #</b> <i>(0 - 16,383)</i>	Same as location A
<b>Freq. Channel</b>	<input type="checkbox"/> CH1 (2,415.6MHz) <input type="checkbox"/> CH2 (2,428.4 MHz) <input checked="" type="checkbox"/> CH3 (2,441.2 MHz) <input type="checkbox"/> CH4 (2,454.0 MHz) <input type="checkbox"/> CH5 (2,466.8 MHz)	<b>Freq. Channel</b>	Same as location A
<b>Master or Slave</b> <i>(one end must be Master, other end must be Slave)</i>	Master	<b>Master or Slave</b>	Slave
<b>Sync Generator Status</b>	<input type="checkbox"/> None <input checked="" type="checkbox"/> Primary <input type="checkbox"/> Secondary <input type="checkbox"/> Tertiary	<b>Sync Generator Status</b>	<input checked="" type="checkbox"/> None <input type="checkbox"/> Primary <input type="checkbox"/> Secondary <input type="checkbox"/> Tertiary
<b>Transmit Power</b> <i>(If manual, specify value from +24 dB to -14 dB)</i>	<input checked="" type="checkbox"/> Auto <input type="checkbox"/> Manual	<b>Transmit Power</b>	<input checked="" type="checkbox"/> Auto <input type="checkbox"/> Manual

Figure 3-6. Sample Configuration Worksheet (Complete)



## FCC ID: NFX-RCC0001-00

### 3.5 Pre-Installation Testing

To ensure satisfactory operation between two WISL systems, they may be tested together before being transferred to their eventual destinations. For testing in close proximity, the RF emulation cable supplied in the System Installation kit must be used.

**CAUTION**

Do not under any circumstances attempt to test two RadioWire Modems in close proximity, with their antennas installed. To do so may result in severe damage to both units, due to excessive signal load on the receivers.

- Two units equipped with +14dBi helical antennas may not work satisfactorily at any distance less than 130 meters.
- Two units equipped with +24dBi helical antennas may not work satisfactorily at any distance less than 1.3 kilometers.

The procedure for pre-installation testing is as follows:

- 1) After configuring each of the two WISL systems, disconnect power to both of them.
- 2) Carefully remove each RWM from its antenna using the Allen key supplied in the System Installation kit. Set aside the antennas for later re-attachment.
- 3) Place the two RWM units on a flat surface about 2-3 feet apart, with their antenna sockets uppermost. Connect the RF emulation cable between the two sockets.
- 4) Connect each RWM to its NIM (if not already connected), using the 3-foot cables supplied in the System Installation kit.
- 5) Power up both systems. Within about 20 seconds, the green LED on each RWM should turn on solidly and the red LED should be off. In addition, the 'Lock' (LCK) indicator on the NIM front panels should both be on (green), and the 'Error' (ARQ) indicator should be off. If this is the situation, the two WISL systems are communicating satisfactorily, and you can move on to step 6). Otherwise, refer to 'Troubleshooting' (Section 3.5.1) below.
- 6) This step is optional. If you have the necessary equipment available for transferring user data across the link, make the necessary connections to the two NIMs, and ensure that data transfer is working correctly. If not, refer to 'Troubleshooting' (Section 3.5.1) below.

#### 3.5.1 Troubleshooting

**FCC ID: NFX-RCC0001-00**

Attach the combined RWM/antenna assembly to the mounting bracket on the pole. Once again, the method of attachment for the 1-meter antenna is different than for the other two antennas. (\*\* 1-meter antenna TBD \*\*).

For the two smaller antennas, it is the RWM that attaches to the mounting bracket. On the rear of the RWM enclosure, there is a metal strip that serves as a hook. It allows the RWM to be hung on the mounting bracket in the correct position for the large knurled fasteners to be screwed into the RWM (Figure 3-7). This hook-and-lip system makes it possible to complete attachment of the RWM/antenna assembly using only a single hand, which may be necessary in situations where you need to use your second hand for support.

Later on, elevation and azimuth adjustments will be made via the mounting bracket, in order to align the RWM units at the two ends of the link. But for the moment, the next step is to install the cable from the roof down to the NIM location. Begin by securely connecting the cable to the RWM. This will anchor the upper end of the cable while the other end is being pulled down.

FCC ID: NFX-RCC0001-00

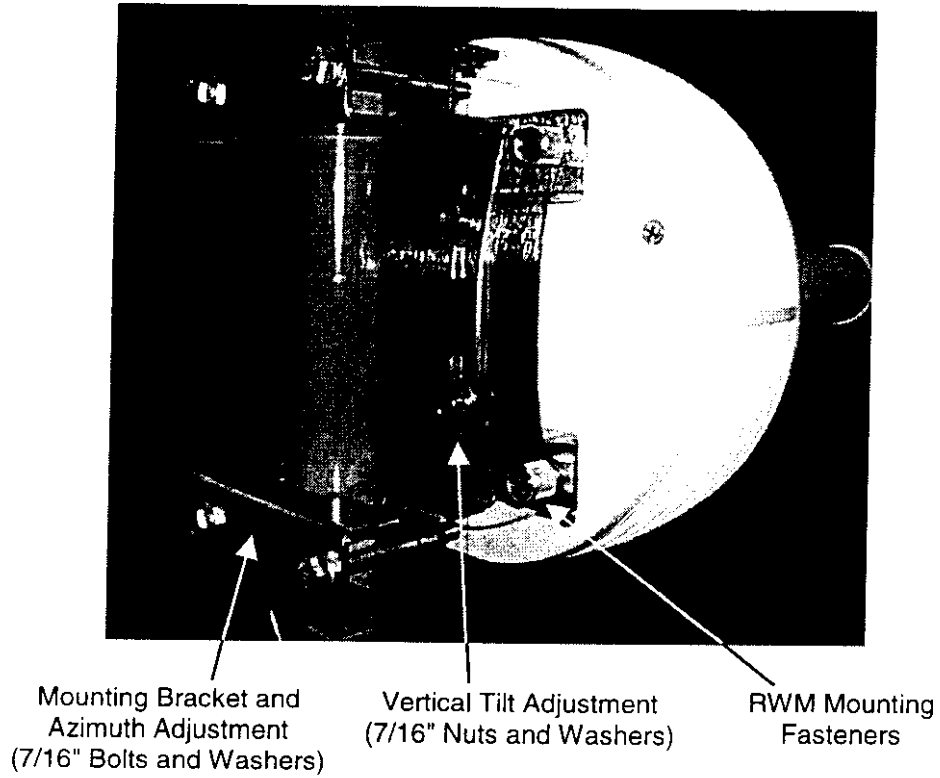

Figure 3-7. RWM Mounting Bracket

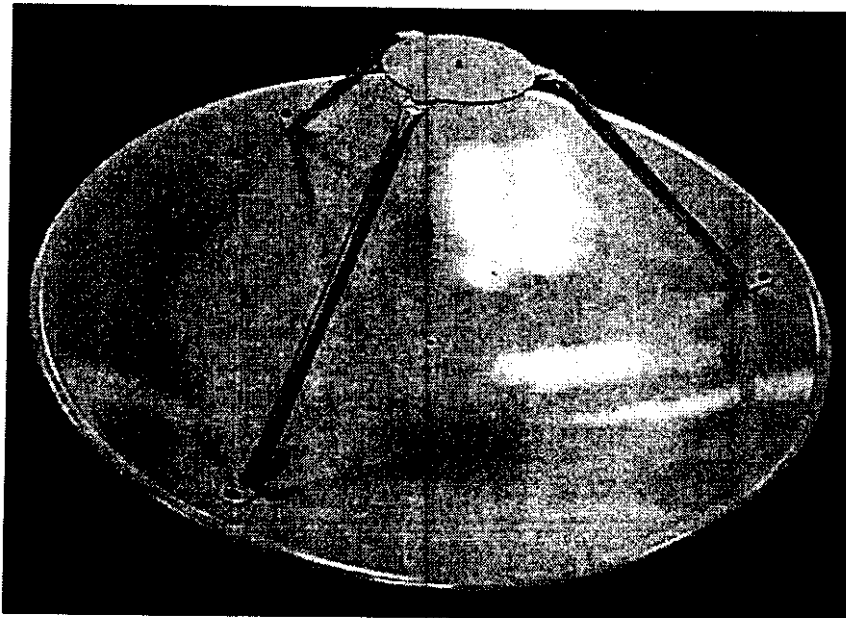
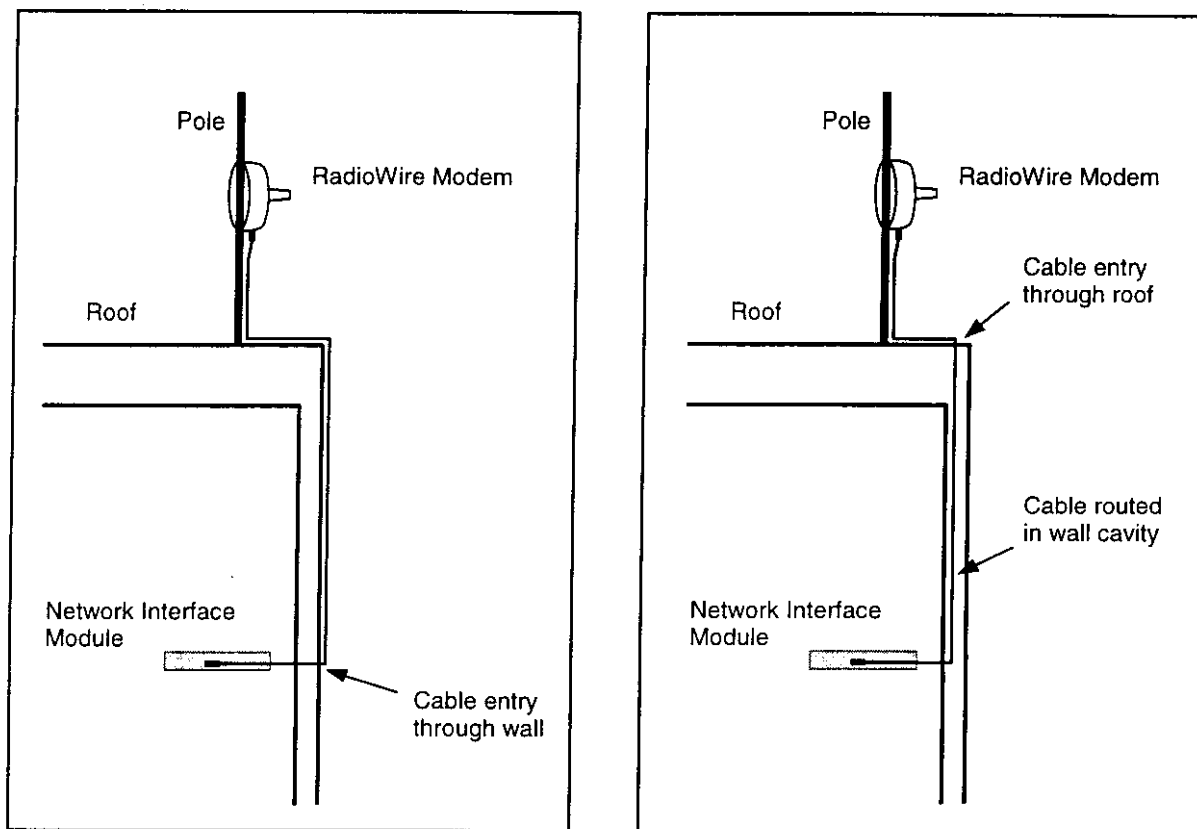

Figure 3-8. 1-meter Antenna

## FCC ID: NFX-RCC0001-00

**3.6.2 Cable Installation**

At this point, you must determine whether a cable puller tool will be needed. For example, if the cable will be run external to the building walls, the tool will probably not be needed (Figure 3-9). Similarly, if a clear vertical path is available within the wall cavity, the cable can be installed without the need for a puller.



**Figure 3-9. Internal and External Cable Routing**

However, cable routing is typically not as straightforward as shown here. Often, obstacles within the wall cavities must be circumvented, or the cable must travel through a combination of wall and floor cavities. In these cases, use a cable puller, starting from the NIM location and working the steel tape up to the roof.

Next, return to the roof, and slide the cable pull grip fully over the open end of the cable, ensuring that no slippage occurs once the grip is in place (Figure 3-10). Now connect the loops at the ends of the cable pull grip and the steel tape, using a nylon tie wrap threaded through them both. Trim the free end of the tie wrap, so that it will not catch on anything as it passes through wall and/or floor cavities.

Return to the NIM location, and proceed to carefully reel-in the steel tape until the cable reaches you. During this procedure, it may be useful or necessary to have the assistance of a second person on the roof to feed the cable, ensuring that it does not get tangled.

You are now ready to install the DB-25 connector on the NIM end of the cable. Remove the cable pull grip from the cable end, by pushing it off from its open end. This compresses the mesh, thus releasing its friction grip on the cable and allowing it to slide off.

**FCC ID: NFX-RCC0001-00**

Separate the two halves of the DB-25 connector shell and remove the main body (see Figure 3-11). Using the pin-out information provided in Appendix F, carefully insert the pins into the numbered holes, from the rear of the main body. Ensure that all pins are fully seated and protrude from the connector an equal amount. Clamp the two shell halves back over the cable and main body assembly, ensuring that the braided grounding sheath of the cable makes full contact with the shell halves at the cable-entry collar. Insert and tighten the screw that holds the two halves together.

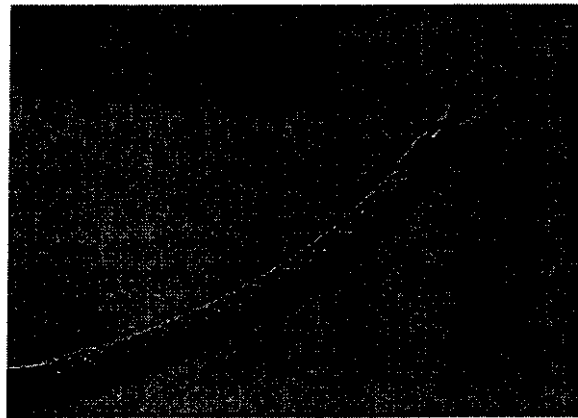

**Figure 3-10. Cable Pull Grip**

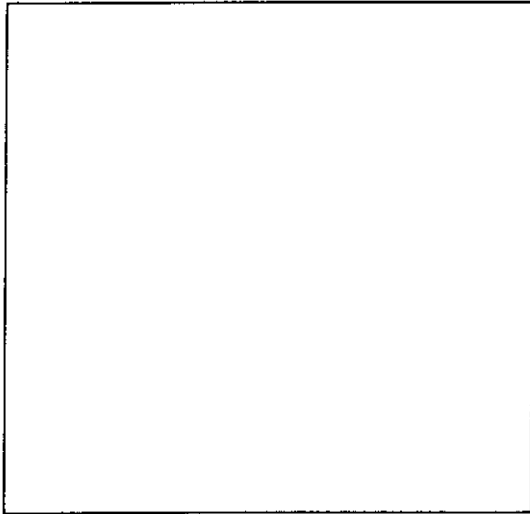

**Figure 3-11. DB-25 Connector**

At this point you may optionally test the complete cable for correct assembly and lead continuity, using the tester provided in the System Installation kit. To do so, go up to the roof, disconnect the cable from the RWM, and install the loop-back terminator on the cable connector. Return to the NIM location and install the display terminator component of the tester.

(\*\*\*\* Add tester operating procedure \*\*\*\*)

After removing the test terminators, reconnect the cable to the RWM.

### **3.7 Installing the Network Interface Module**

The Network Interface Module must be located in the vicinity of the user equipment to which it will be connected. It may either be installed as a freestanding unit on a suitable surface such as a shelf, or a pair of NIM units may be attached side-by-side and rack-mounted in a standard 19" rack. A special RadioConnect Universal Rack-Mount kit (Figure 3-xx) is available from your reseller for this purpose (part number 250-0001-00).

If multiple WISL systems are being installed at the same location, they must be interconnected using the synchronization cables provided. Refer to Section 2.2.3 for details of how to "daisy-chain" multiple NIM units together.

After physically installing the NIM unit(s), connect the cable from the RWM, to the appropriate DB-25 socket on the rear panel.

**FCC ID: NFX-RCC0001-00****3.7.1 Electrical Requirements**

The system is now ready to be powered up. Connect the power cord to the NIM. For compliance with safety regulations, the NIM must be connected to a properly grounded electrical circuit.

The foregoing procedure for mounting the RadioWire Modem and antenna, installing the RWM-to-NIM cable, and installing the Network Interface Module, must next be repeated for the WISL system at the other end of the link. Once this has been done, you are ready to proceed with alignment of the systems.

**3.8 Antenna Alignment Procedure**

With power applied to both WISL systems, return again to the roof at one end of the link. Inspect the LEDs on the underside of the RadioWire Modem. If the green LED is on solidly, and the red LED is off (i.e. not flashing), no further adjustment is needed. Simply tighten all bolts and fasteners as much as possible, using the tools provided.

If the status of the LEDs is not as required, carefully loosen the mounting bracket bolts just enough to be able to rotate the Modem around the pole. Be sure that while you do this, you support the unit so that it does not slide down the pole. Next, adjust the azimuth in small increments to the left or right, until the optimum LED status is achieved. If it is not possible to find an ideal position at which the green LED is on solidly and the red LED is fully off, then the best position is that at which the flashing of the red LED is minimized. Once this is accomplished, tighten the mounting bracket bolts as much as possible.

You may also try optimizing the LED status by adjusting the elevation angle of the RWM. Do this by loosening the vertical tilt bolts on the mounting bracket, then tilting the unit up or down in small increments.

Once the best possible combination of red and green LED status is achieved, tighten all bolts and fasteners as much as possible.

Repeat this alignment procedure at the other end of the link.

**3.9 Connecting to User's Equipment**

The final step in installing your Wireless Internet Service Link is to connect the NIM at each end of the link to its associated user equipment. (\*\*\*) More information to be added (\*\*\*)

## FCC ID: NFX-RCC0001-00

## 4 Operation

### 4.1 Operating Commands

(\*\* TBD \*\*)

### 4.2 Troubleshooting

The table below is provided to assist in troubleshooting any difficulty you are likely to encounter. (\*\* Following table to be revised and enhanced \*\*)

Symptoms	Possible Causes
Both LEDs on bottom of RWM off.	NIM not powered
	Cable between RWM and NIM not connected or damaged.
Green LED (Signal Quality/Power) flashes once every two seconds.	Polarity of antennas not the same at both locations. Antenna cap colors must match at both location.
	Antenna(s) not pointed properly..
	RWM at other end not powered.
	Master/Slave configured improperly. Only one end of link must be a master and other a slave.
Red LED (ARQ) continuously on.	Pseudo-random Code Channel configured improperly. Both RWMs must be configured with identical Pseudo-random Code Channel.
	Transmit Power Attenuation set too high at far end. Set Transmit Power Attenuation to 0 at far end.
	Channel Selection configured improperly. Both RWMs must be configured with identical Frequency Channel.
	One or both RWM is in Self-Test mode. Reconfigure RWM to Normal mode.
LEDs appear normal, but no data.	Interfering transmitter. Select a different Frequency channel and Pseudo-random Code Channel.
	Multiple RWMs operating at same site. Attach synchronization cables between all RWMs at site and assign Timing Leader numbers to all units.
LEDs appear normal, but no data.	One RWM within link is configured in Loopback mode. Reconfigure RWM to Normal mode.
	One or both RWM within link is configured in Diagnostic mode. Reconfigure RWM to Normal mode.

**Table 4-1. Troubleshooting Chart**

**FCC ID: NFX-RCC0001-00****4.3 Customer Support**

If your problem can not be fixed by reading the troubleshooting section in this manual (Chapter 4) and your local distributor can not resolve the situation, please contact RadioConnect Corporation Technical Support at 310-338-3388 between 9:00 AM and 5:00 PM Pacific Standard Time.

RadioConnect Corporation  
6041 Bristol Parkway  
Culver City, CA 90230  
Tel: (310) 338-3388  
Fax: (310) 338-3399  
Internet: [www.radioconnect.com](http://www.radioconnect.com)  
e-mail: [info@radioconnect.com](mailto:info@radioconnect.com)



FCC ID: NFX-RCC0001-00

**APPENDIX A Technical Specifications - RadioWire Modem**

Operating frequency:	2,400 - 2,483.5 MHz
Burst clocking rate:	800 kbps
User-data throughput:	256 kbps, full-duplex
RF channel bandwidth:	25.6 MHz (main lobe)
RF channels:	3 (non-overlapping), 5 (with overlap)
Receiver sensitivity:	-90 dBm @ $1 \times 10^{-6}$ BER
Transmit power:	<0 to +24 dBm
Range with: +24 dBi antenna	20 miles (32 km) – limited by protocol.
+20 dBi antenna	20 miles (32 km)
+14 dBi antenna	6 miles (10 km)
Data modulation:	OQPSK
Code division channels:	>16,000
Spreading method:	Direct sequence
Spread code length:	32,768 chips
Process gain:	15 dB
Max acquisition time:	10.5 sec. each way
Max signal loss time w/o loss of sync.	More than 1 second
Antenna polarization:	Circular - right or left
Built-in alignment LEDs:	Signal strength, Packet errors
Size:	8.50"(dia.) x 4.00"(w/o antenna)
Environment temperature:	-40 to +60 deg. C
Environment humidity:	10% - 100%, condensing

FCC ID: NFX-RCC0001-00

## APPENDIX B Technical Specifications - WISL Network Interface Module

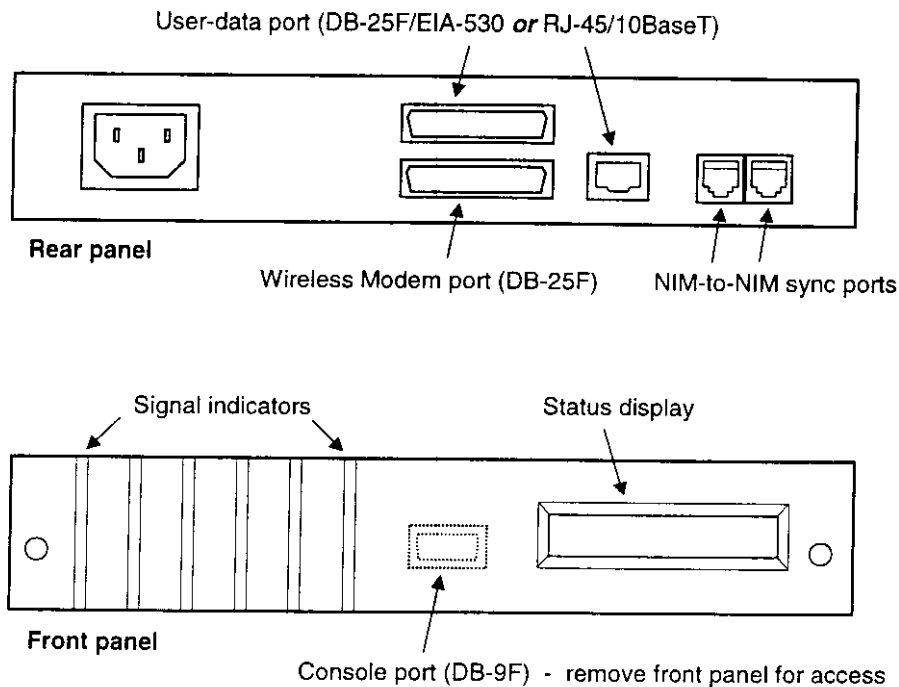

- Ports:
  - User-data
  - Wireless modem
  - NIM-to-NIM synchronization
  - Console
- User interface:
  - Serial (EIA-530) **or** Ethernet (10BaseT)
- Connectors:
  - DB-25 (serial interface) **or** RJ-45 (Ethernet)
- Serial link layer:
  - Protocol-independent
- Ethernet link layer:
  - Bridge
- Power:
  - 90 - 264 VAC (auto-sensing), < 1.0 Amp, 47-63 Hz
- NIM location:
  - Stand-alone **or** rack-mount
- NIM size:
  - 8.62"(W) x 8.85"(D) x 1.60"(H)
- Certifications:
  - (pending)
- Operating temperature:
  - 0 to +40 deg. C
- Operating humidity:
  - 10% - 95%, non-condensing

FCC ID: NFX-RCC0001-00

## APPENDIX C Link Configuration Worksheet

Location A		Location B	
<b>Name</b> <i>(for ref. only)</i>		<b>Name</b> <i>(for ref. only)</i>	
<b>Serial Number</b>		<b>Serial Number</b>	
<b>Location</b>		<b>Location</b>	
<b>Latitude</b>		<b>Latitude</b>	
<b>Longitude</b>		<b>Longitude</b>	
<b>Elevation of RWM</b>		<b>Elevation of RWM</b>	
<b>Distance (A to B)</b>			
<b>Azimuth of Loc. B</b>		<b>Azimuth of Loc. A</b>	
<b>Antenna Type</b> <i>(may be different at the 2 locations)</i>	<input type="checkbox"/> Helical <input type="checkbox"/> 0.6 m dish <input type="checkbox"/> 1.0 m dish	<b>Antenna Type</b>	<input type="checkbox"/> Helical <input type="checkbox"/> 0.6 m dish <input type="checkbox"/> 1.0 m dish
<b>Ant. Cap Color</b>	<input type="checkbox"/> White <input type="checkbox"/> Blue	<b>Ant. Cap Color</b>	Same as location A
<b>Antenna Angle in Vertical Plane</b>		<b>Antenna Angle in Vertical Plane</b>	
<b>Pseudo-Random Spreading Code #</b> <i>(0 - 16,383)</i>		<b>Pseudo-Random Spreading Code #</b> <i>(0 - 16,383)</i>	Same as location A
<b>Freq. Channel</b>	<input type="checkbox"/> CH1 (2,415.6 MHz) <input type="checkbox"/> CH2 (2,428.4 MHz) <input type="checkbox"/> CH3 (2,441.2 MHz) <input type="checkbox"/> CH4 (2,454.0 MHz) <input type="checkbox"/> CH5 (2,466.8 MHz)	<b>Freq. Channel</b>	Same as location A
<b>Master or Slave</b> <i>(one end must be Master, other end must be Slave)</i>		<b>Master or Slave</b>	
<b>Sync Generator Status</b>	<input type="checkbox"/> None <input type="checkbox"/> Primary <input type="checkbox"/> Secondary <input type="checkbox"/> Tertiary	<b>Sync Generator Status</b>	<input type="checkbox"/> None <input type="checkbox"/> Primary <input type="checkbox"/> Secondary <input type="checkbox"/> Tertiary
<b>Transmit Power</b> <i>(If manual, specify value from +24 dB to -14 dB)</i>	<input type="checkbox"/> Auto <input type="checkbox"/> Manual	<b>Transmit Power</b>	<input type="checkbox"/> Auto <input type="checkbox"/> Manual

**FCC ID: NFX-RCC0001-00**

## **APPENDIX D Network Interface Specification (Serial)**

**FCC ID: NFX-RCC0001-00**

## **APPENDIX E Network Interface Specification (Ethernet)**

## FCC ID: NFX-RCC0001-00

**APPENDIX F RWM-To-NIM Cable Specification**

The RadioWire RF Modem uses a square-flange AMP Series 2 Circular Plastic Connector receptacle P/N 205840-3 on the housing. The RWM-to-NIM cable mates to the RWM using an AMP P/N 205839-3. The other end of the cable mates to the NIM using a DB-25 connector - male on the cable, female on the NIM rear panel.

The following table shows the signals and cable pin-outs:

Signal Name	Pin Numbers on AMP Connector (at RWM end)	Wire Colors	Pin Numbers on DB-25 Connector (at NIM end)	
GND	1	Black	1	} Twisted Pair (TP)
+10 TO +28 VDC	2	Red	2	
TXHS+	7	Orange	7	} TP
TXHS-	8	Yellow	8	
RXHS+	9	Violet	9	} TP
RXHS-	10	Gray	10	
TXHSC+	11	Pink	11	} TP
TXHSC-	12	Tan	12	
RXHSC+	13	White/Blue	13	} TP
RXHSC-	14	White/Orange	14	
TXSCP+	15	White/Green	15	} TP
TXSCP-	16	White/Brown	16	
RXSCP+	17	White/Gray	17	} TP
RXSCP-	18	Red/Blue	18	
STATUS+	19	Red/Green	19	} TP
STATUS-	20	Red/Brown	20	
TXSYNC+	21	Red/Gray	21	} TP
TXSYNC-	22	Green/Blue	22	
CHASSIS GND	23	Bare wire	23	
N/C	24		24	
N/C	25		25	
N/C	26			
N/C	27			
N/C	28			

**Table F-1. Interface Pin Outs**