

Configuring the Link

This chapter describes the link configuration procedure, which is performed after the installation of both sides of the RADWIN 1000/2000 link, as set out in chapters 3 and 4.

Link configuration uses a Link Configuration Wizard to redefine the configuration parameters and fine-tune an operational link. Both sides of the link are configured simultaneously.

The following parameters are configured using the Link Configuration Wizard:

- System parameters
- Channel settings
- Transmission power and antenna settings
- Service parameters

Link Configuration: Getting Started

The Main Window of the RADWIN Manager

Ensure that the RADWIN Manager is running.

The main window should look similar to that in [figure 5-1](#):

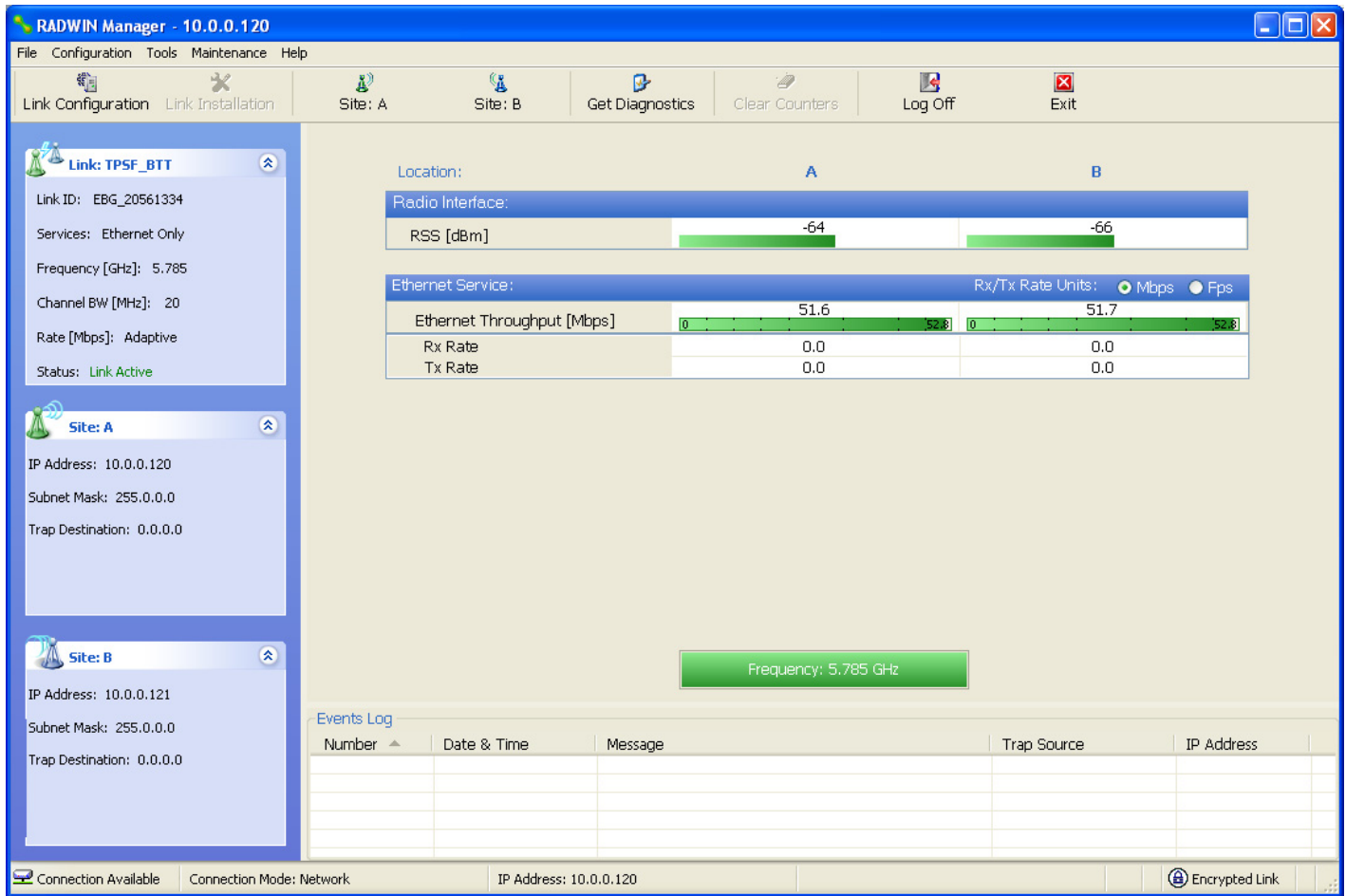

Figure 5-1: Main window, Wireless Link is Active

Before starting a configuration session, make sure that a communication link exists between the two sides of the link.

The Link Status indication bar must be green. In the Link Status panel, the Status field should show Link Active in green.

The main window of the RADWIN Manager contains a large amount of information about the link. Before proceeding to details of link configuration we set out the meaning of each item in the main window.

The RADWIN Manager Toolbar

In configuration mode, the RADWIN Manager toolbar contains the following buttons:

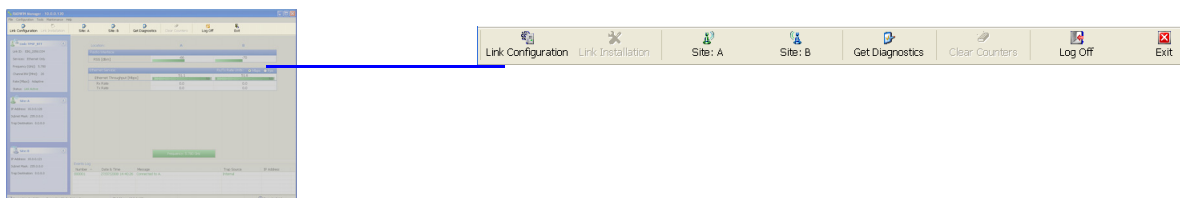

Table 5-1: RADWIN Manager Toolbar

Item	Description
Link Configuration	Changes configuration parameters of an operating wireless link; assigns text files for storing alarms, statistics and configuration data. This button is disabled until a link installation has been completed
Link Installation	Performs preliminary configuration of the system. This button is disabled after the link is installed
Site: <Site 1 name>	Opens the Site configuration dialog for Site A. Same as Configuration 1 Configure <Site 1 name>
Site: <Site 2 name>	Opens the Site configuration dialog for Site B. Same as Configuration 2 Configure <Site 2 name>
Get Diagnostics	Obtain system information
Clear Counters	Disabled
Log off	Closes the current session and logs off RADWIN Manager
Exit	Exits RADWIN Manager

The RADWIN Manager Main Menu

The RADWIN Manager menu, is shown in [table 5-2](#) below:

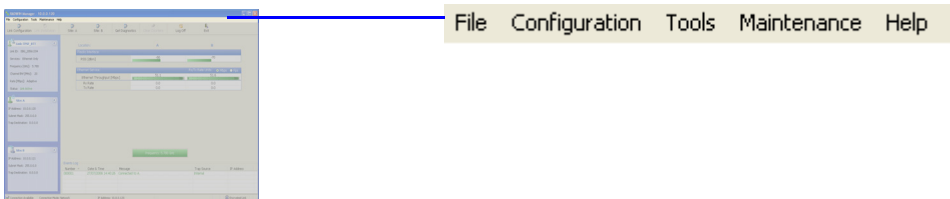

Table 5-2: RADWIN Manager main menu functionality

Menu level			Function	Reference	
Top	+1	+2			
File					
	Log Off		Return to Log On dialog. Same as Log Off button		
	Exit		Exit the manager. Same as Exit button		
Configuration					
	Link Configuration		Run the Configuration Wizard. Not available in installation mode		
	1 Configure <Site 1 name>		Provides limited configuration for site. Has a path to return to installation mode		
	2 Configure <Site 2 name>		Provides limited configuration for site. Has a path to return to installation mode		
	Installation		Runs the Installation Wizard. Not available in configuration mode		
Tools					
	Performance Monitoring Report				
	Active Alarms				
		1 <Site 1 name>	Shows active alarms for <Site 1 name>		
		2 <Site 2 name>	Shows active alarms for <Site 1 name>		
	Change Password		Change the Log On password dialog	page 4-7	
	Events Log				page 7-10
			Clear Events	Clear local events log	
			Save to File	Save events log file	
Preferences		Local preferences dialog			

Table 5-2: RADWIN Manager main menu functionality (Continued)

Menu level			Function	Reference	
Top	+1	+2			
Maintenance					
	Clear counters		Disabled		
	Loopbacks		Disabled		
	Reset				
			1 <Site 1 name>	Reset <Site 1 name> ODU	
			2 <Site 2 name>	Reset <Site 2 name> ODU	
Help					
	RADWIN Manager Help		View online version of the User Manual		
	Link Budget Calculator		Calculator opened in default browser	Appendix D	
	Get Diagnostics Information		Obtain system information	page 7-1	
	About RADWIN Manager		Manager build and system information		

Elements of the RADWIN Manager Main Window

Link details pane

The Link details pane on the left is split into three sections. The top section summarizes information about the link:

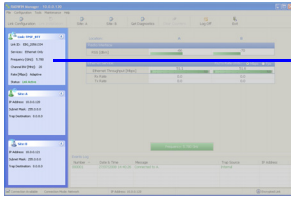

Link: TPSF_BTT

Link ID: EBG_20561334

Services: Ethernet Only

Frequency [GHz]: 5.785

Channel BW [MHz]: 20

Rate [Mbps]: Adaptive

Status: Link Active

Table 5-3: Link Details

Item
Link ID
Services selected
Frequency
Channel bandwidth
Rate
Link status

The two lower panels show basic link site details:

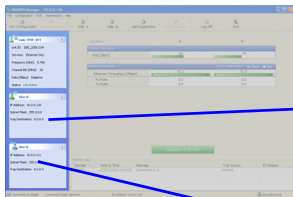

Site: A

IP Address: 10.0.0.120

Subnet Mask: 255.0.0.0

Trap Destination: 0.0.0.0

Site: B

IP Address: 10.0.0.121

Subnet Mask: 255.0.0.0

Trap Destination: 0.0.0.0

Table 5-4: Link site details, Site A and Site B

Item
IP Address
Subnet Mask
Trap Desalination

Monitor pane

The monitor pane, is the main source of real time information about link performance at both link sites. It includes the following panes (top to bottom):

- Radio Interface, Received Signal Strength (RSS) in dBm

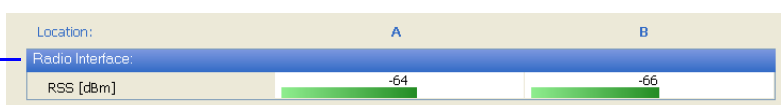
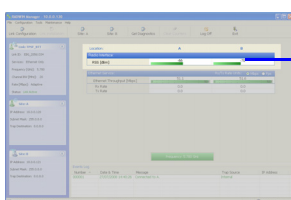

- Ethernet Service:

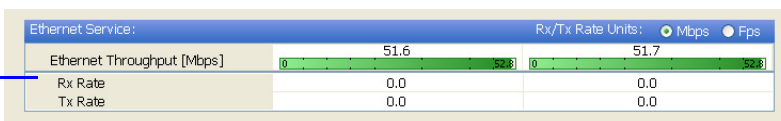
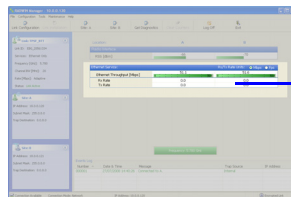

- Ethernet Throughput: The numbers are the current calculated throughputs at each site. The colored bars (with numbers) indicate the maximum possible throughput having regard for air conditions.
- Rx and Tx Rates: Actual Ethernet traffic received and transmitted rates per site, in Mbps of Fbps.

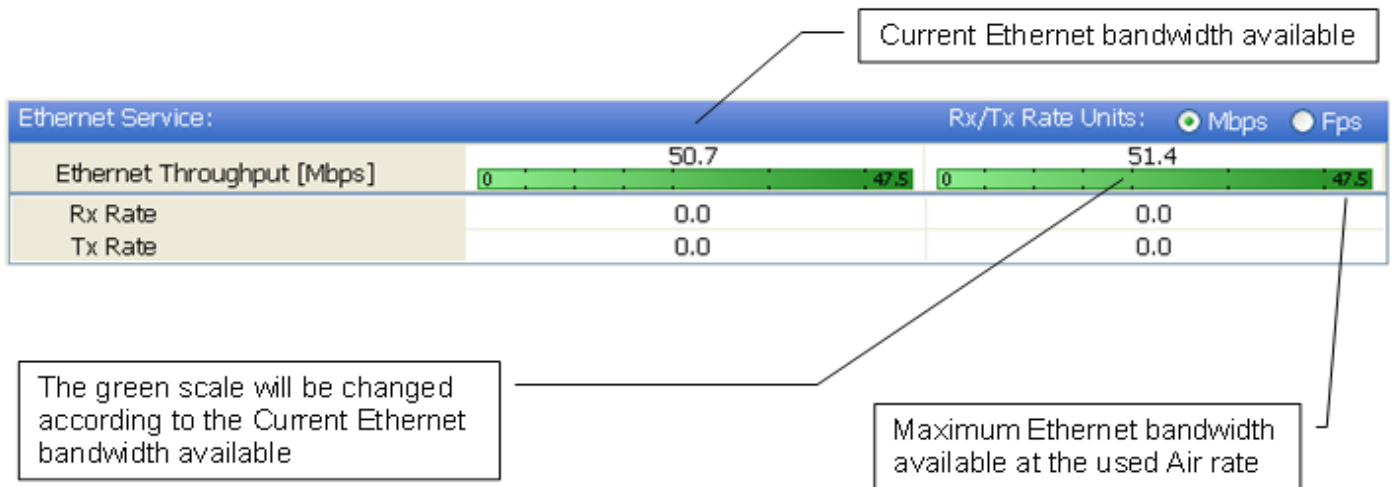
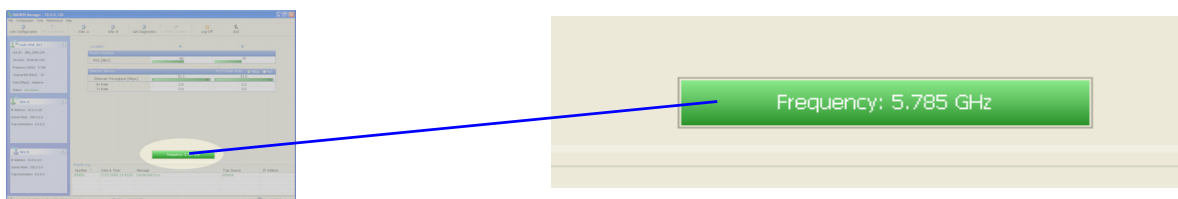

Figure 5-2: Ethernet Bandwidth Indication



- Frequency box: It shows the link frequency. The color of the box indicates the status
 - Green is an active link
 - Red is an inactive link
 - Magenta shows an authentication or compatibility problem
 - Brown shows severe compatibility problem

Events Log

The Events Log, stores alarms generated from both sides of the link and is detailed in chapter 7, [The Events Log](#).

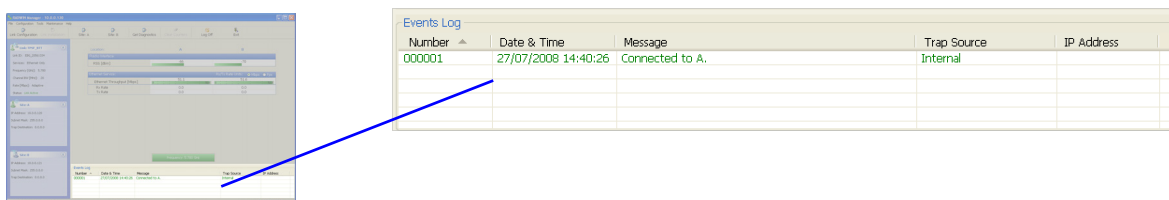

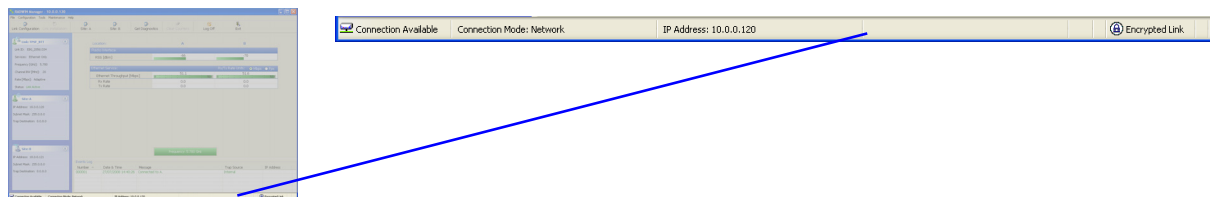

Status Bar



The Status bar, displays the following icons:

Table 5-5: Status bar indicators

Icon or Label	Purpose
Connectivity	Shows if RADWIN Manager is communicating with the ODU.
Connection available	Connection mode to the ODU <ul style="list-style-type: none"> • Over-the-Air connection - using the IP address of the remote unit. • Local connection - direct connection to the IDU without using an IP address. • Network connection - through a LAN
IP Address	Login IP address
Encryption indicator	 Normally encrypted link  Link password validation failed. The link is encrypted with default keys. Service and configuration are unavailable. Change the link password.



Note

There are several “floating” icons, which appear under specific conditions

Configuring the Link: Overview

The Configuration Wizard has seven steps as shown in [table 5-6](#) below.

Table 5-6: Link Configuration Wizard

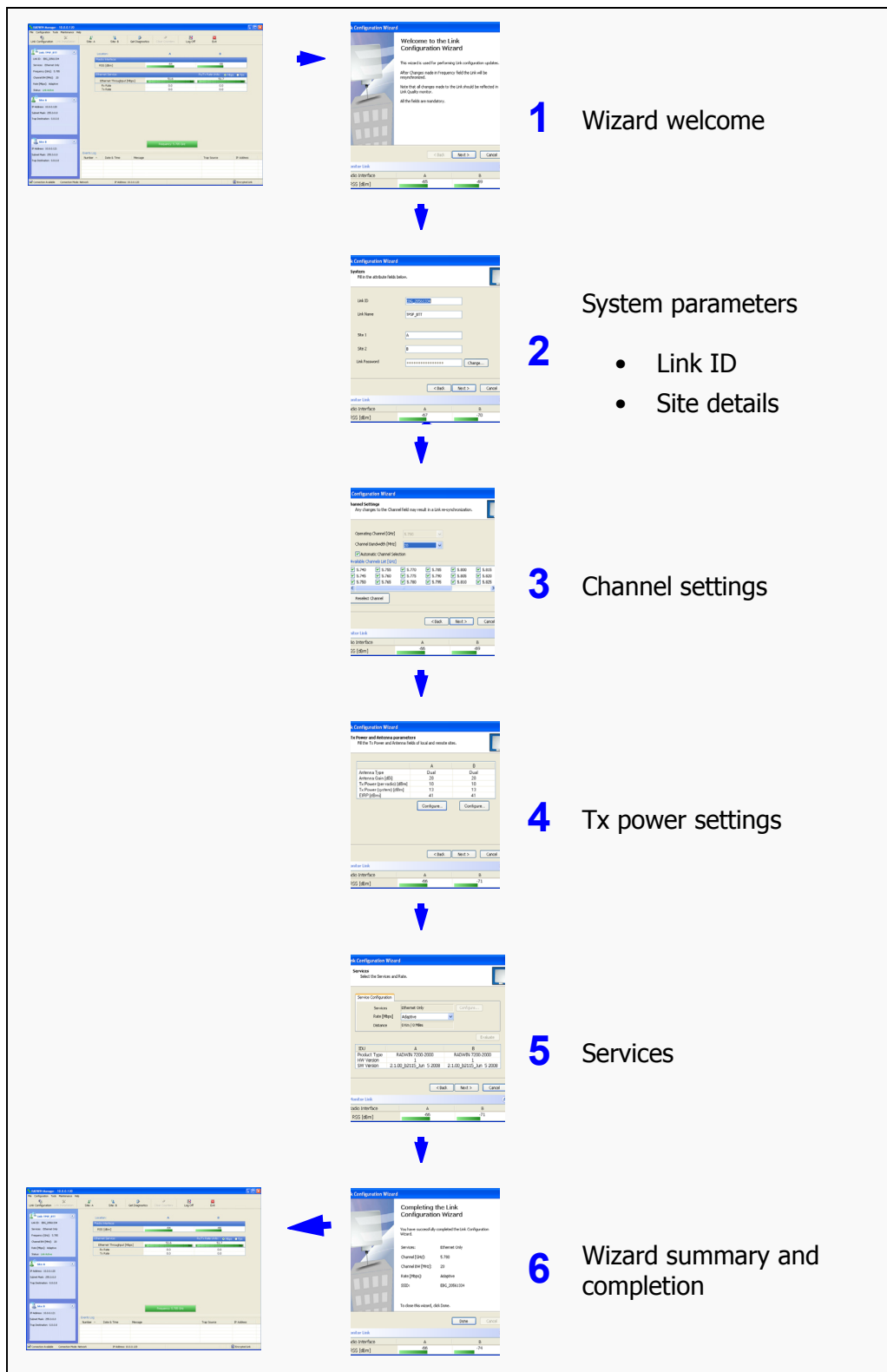

Since configuration functionality is included in the installation, we will briefly review the main steps and for most part offer references to the corresponding installation step.

Configuring the Link: Step 1, Start the Wizard

In the tool bar of the RADWIN Manager main window, click the **Link Configuration** button. The Link Configuration button is only accessible on a fully installed link as set out in chapter 4.

The Configuration Wizard opens:

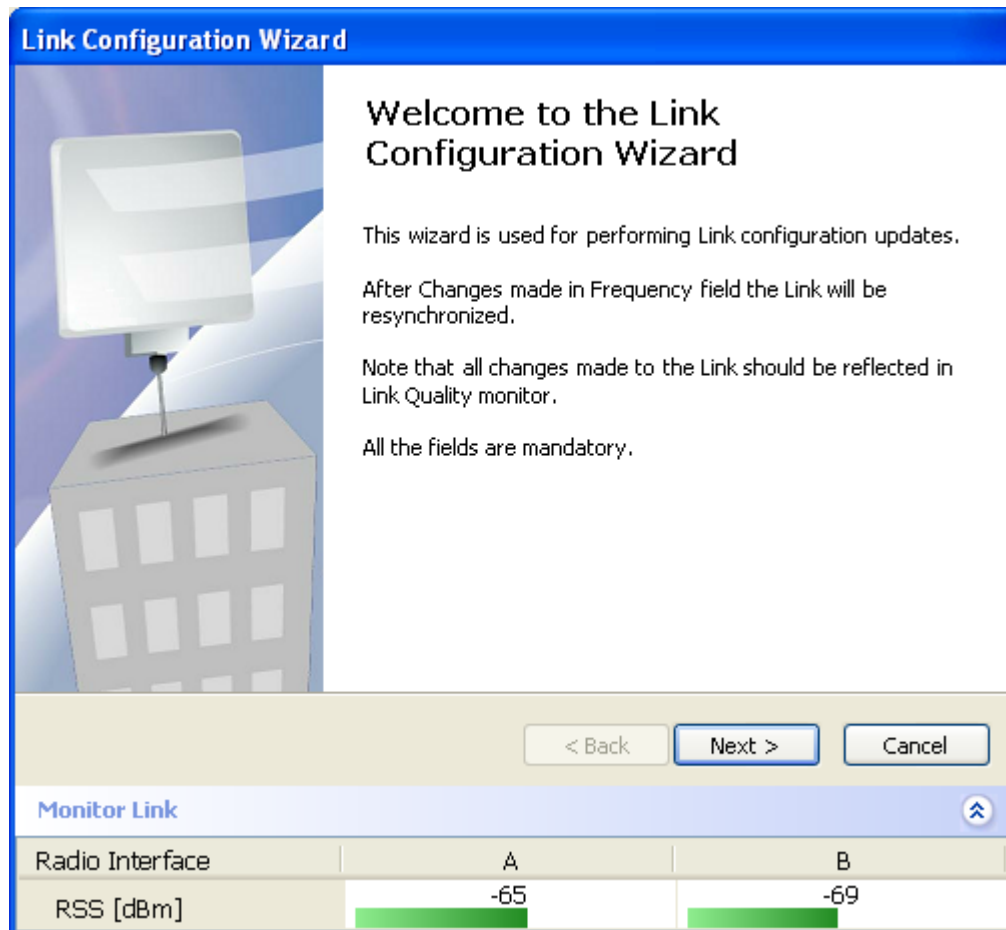

Figure 5-3: Link Configuration Wizard

Click **Next** to proceed with the configuration procedure.

Configuring the Link: Step 2, System Parameters

The System dialog box opens:

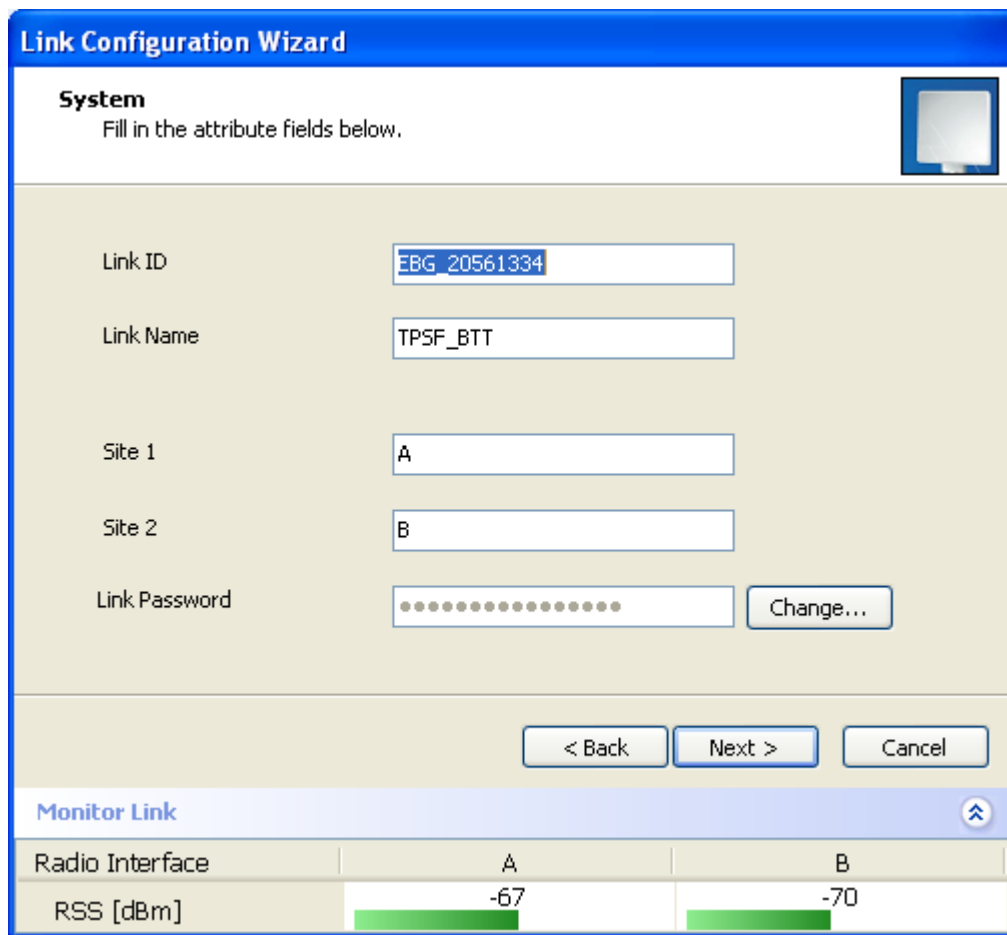

Figure 5-4: Configuration Wizard, System dialog box

The System attributes may be edited and the Link Password may be changed exactly as in the corresponding Link Installation step on [page 4-14](#).

Click **Next** to continue.

Configuring the Link: Step 3, Channel Settings

Configuring the Channel Settings follows the same pattern as the Installation procedure:

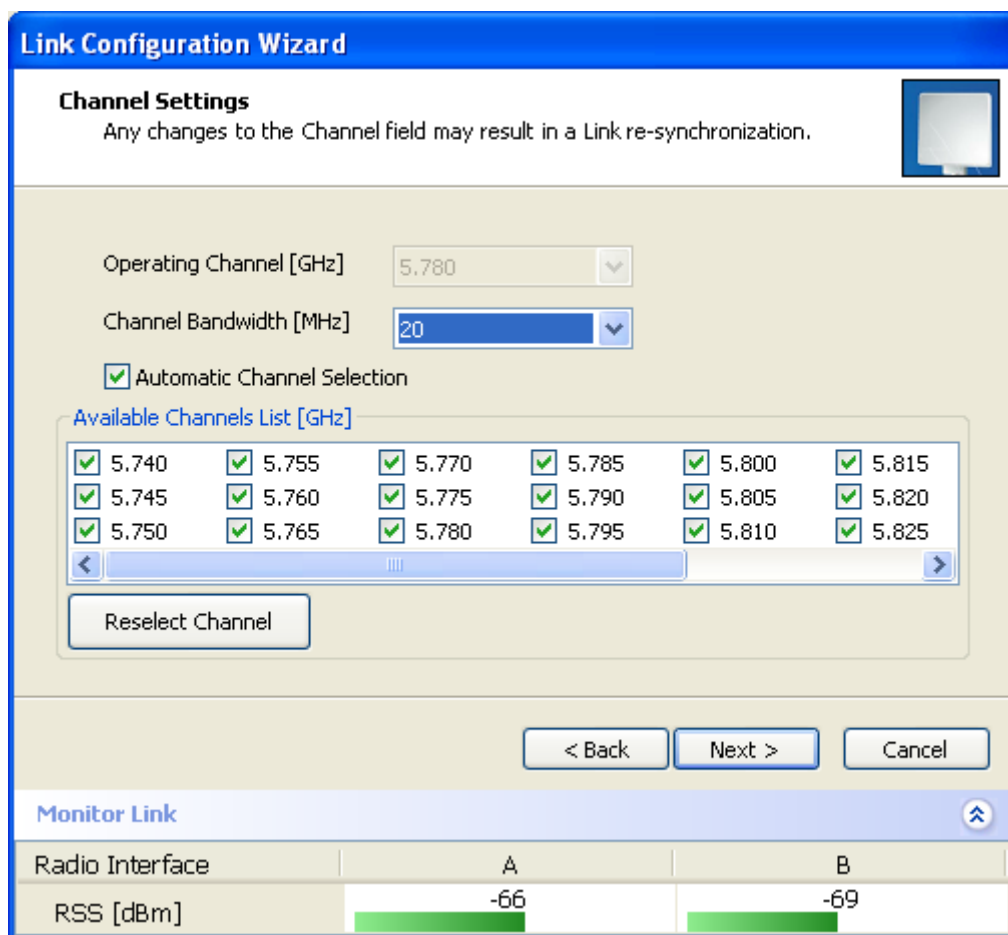
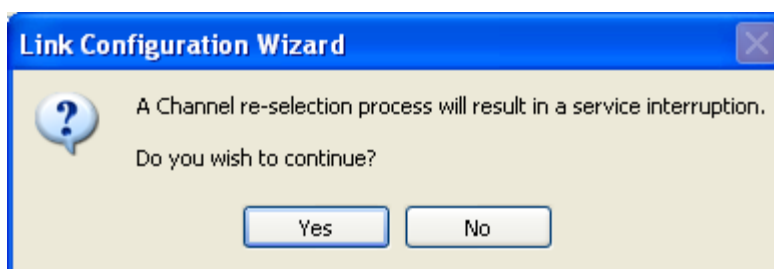

Figure 5-5: Channel Settings dialog box - Automatic Channel Selection

Notice that the operating channel is grayed out. If you use the **Reselect Channel** button, to change it, you will be asked for confirmation:



If you accept, then the system will search for the best operating channel:

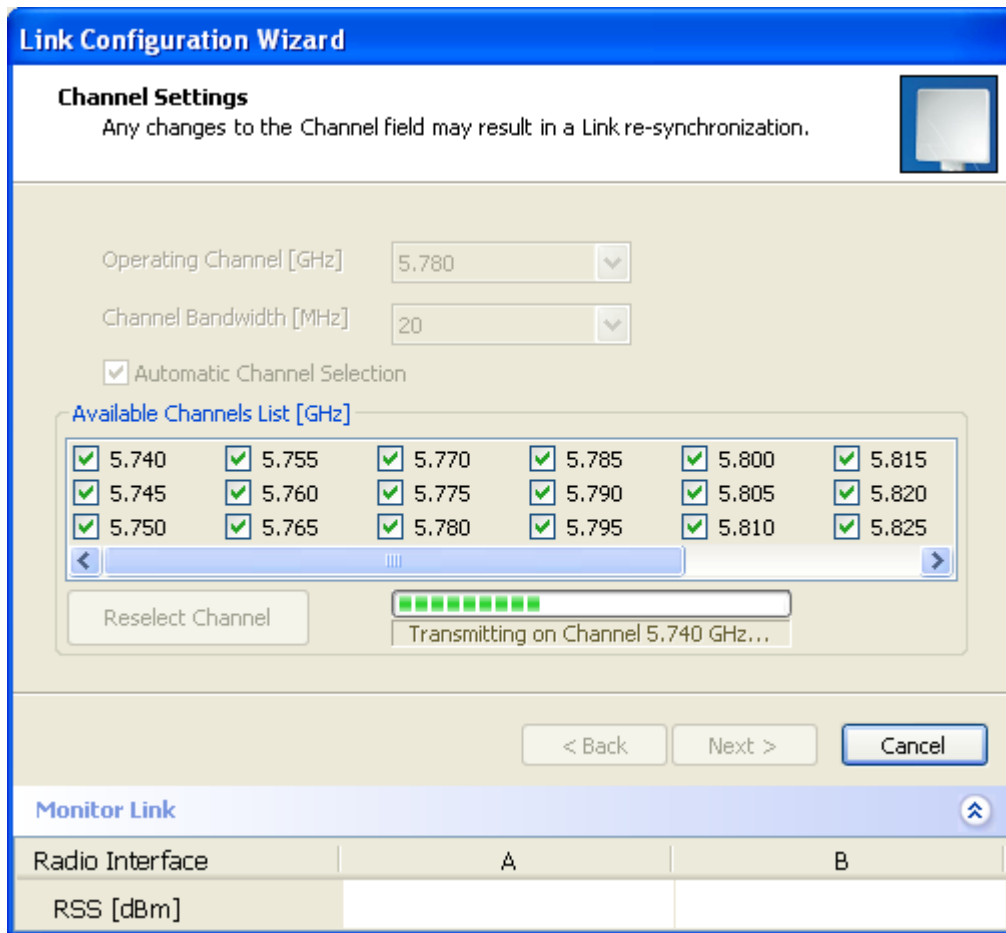

Figure 5-6: Searching for the best operating channel

The link will return to the status of [figure 5-5](#) above with a possible change to the operating channel.

If you work without automatic channel selection, the Channel Settings window looks like this:

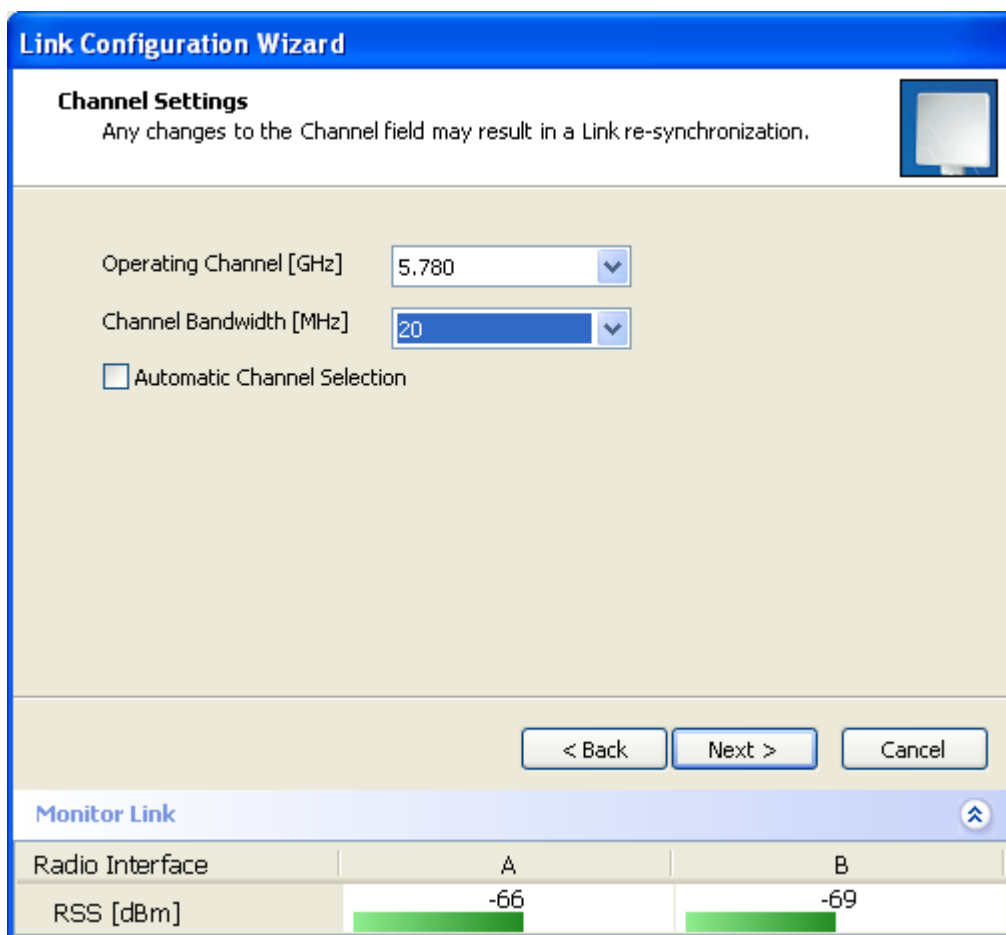

Figure 5-7: Channel Settings without automatic channel selection

If you click the Operating Channel drop-down list, the following window appears:

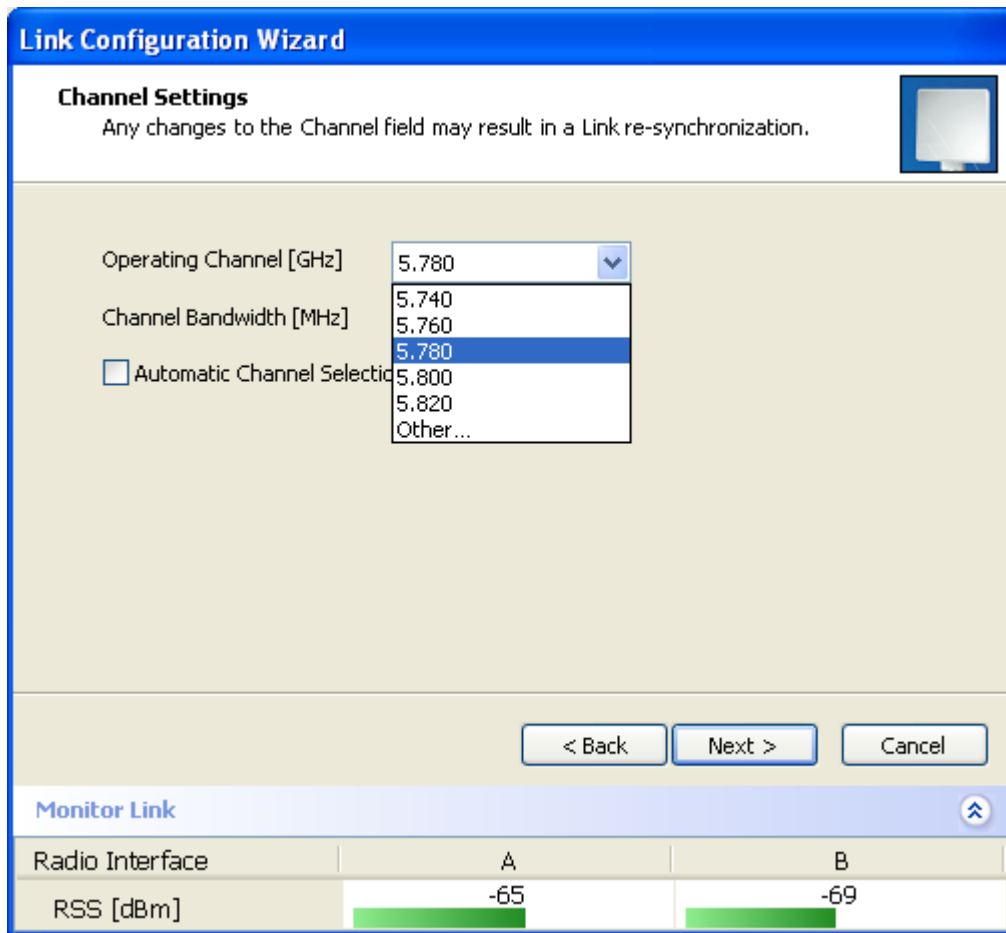

Figure 5-8: Channel frequency options

Selecting one of the frequencies presented returns you to the status of [figure 5-7](#) with the appropriate change. If you choose **Other...**, the following window opens:

Channel Settings
Any changes to the Channel field may result in a Link re-synchronization.

Operating Channel [GHz] Other... 5.800

Channel Bandwidth [MHz] 20

Automatic Channel Selection

< Back Next > Cancel

Monitor Link

Radio Interface	A	B
RSS [dBm]	-65	-69

Figure 5-9: Choosing an "Other" Operating Channel frequency

The right hand drop-down list (showing 5.800) allows you to fine-tune the frequency in increments of ± 5 MHz within a range of 5.740 - 5.835 GHz.

When you have completed making your choice, click **Next** to continue.

Configuring the Link: Step 4, Tx Power and Antenna Settings

Link Configuration Wizard

Tx Power and Antenna parameters
Fill the Tx Power and Antenna fields of local and remote sites.

	A	B
Antenna Type	Dual	Dual
Antenna Gain [dBi]	28	28
Tx Power (per radio) [dBm]	10	10
Tx Power (system) [dBm]	13	13
EIRP [dBm]	41	41

Configure... Configure...

< Back Next > Cancel

Monitor Link

Radio Interface	A	B
RSS [dBm]	-66	-71

Figure 5-10: Transmission Power and Antenna Parameters

If you chose to configure either antenna, you are presented with the following window:

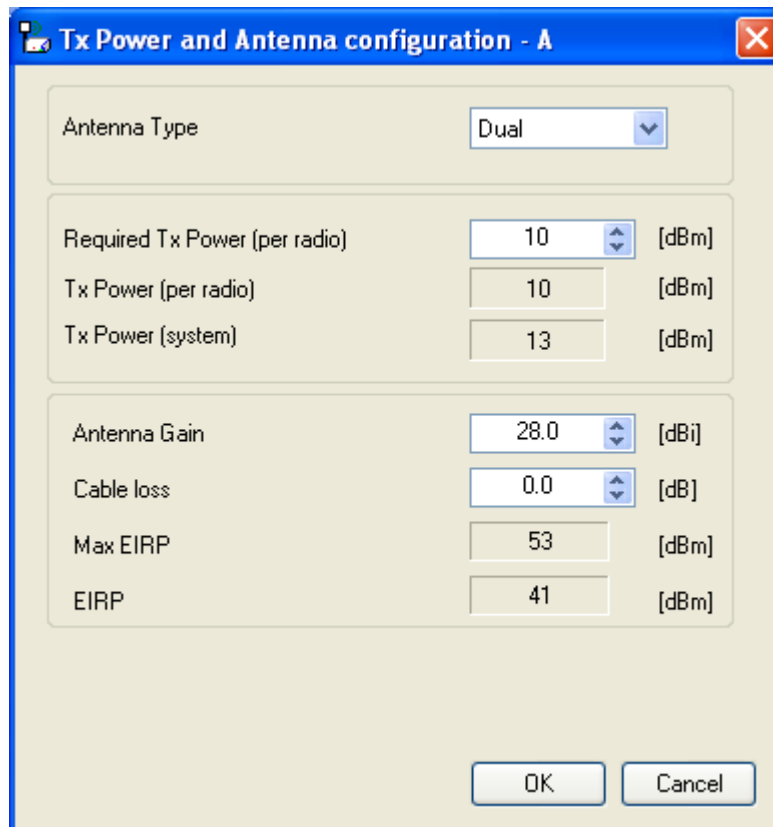
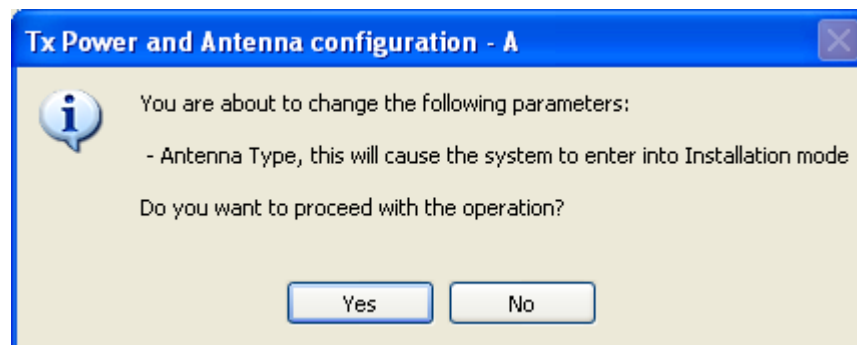

Figure 5-11: Antenna configuration dialog with opened type selection

So far, the procedure duplicates the corresponding Installation process on. If you choose a different antenna type and click **OK**, you will receive the following cautionary message:



Caution

In this context, entering Installation mode causes a service break until it is restored by running the Installation wizard.

If you are uncertain, do not do this without expert technical assistance.

You may also change the Required Tx Power, Antenna Gain and Cable Loss. The procedure is the same as that set out in the Installation procedure on [page 4-23](#).

When you have completed making your choice, proceed to the Services window.

Configuring the Link: Step 5, Services

Here is the services dialog:

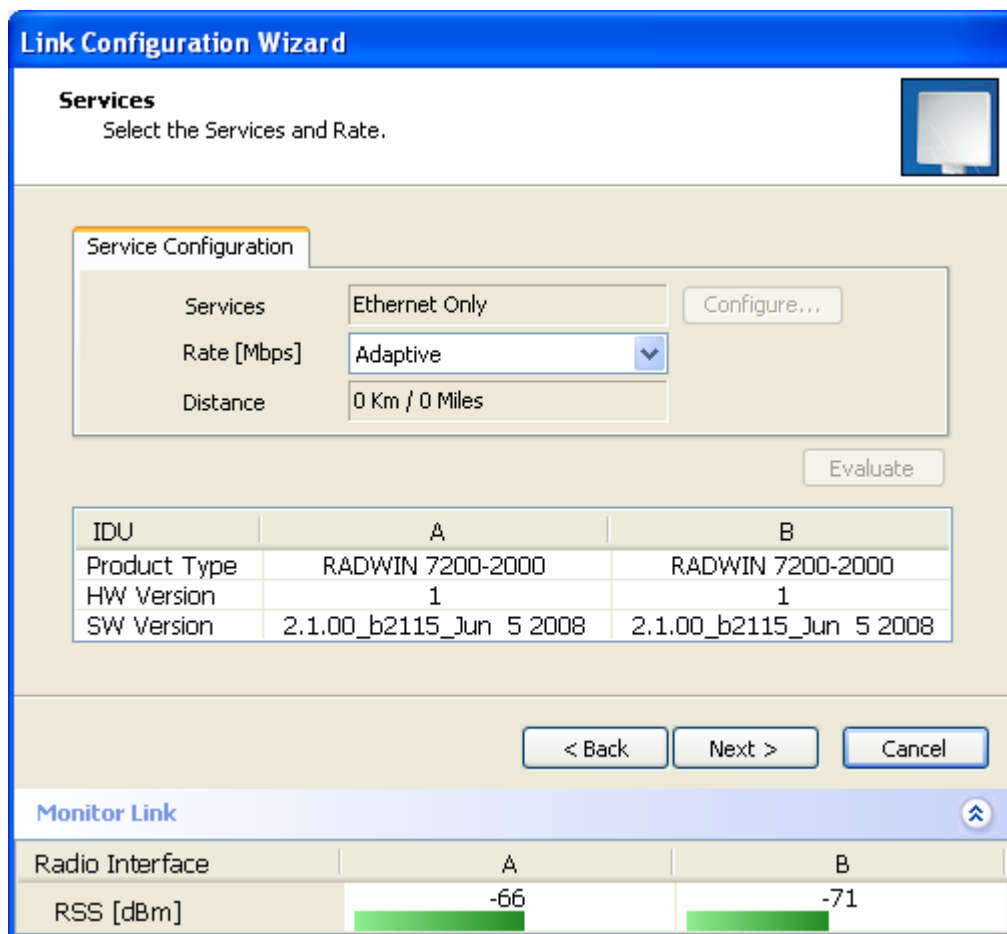

Figure 5-12: Services and Rates dialog

To choose Services, see the corresponding Installation procedure on [page 5-20](#).

Click **Next** to continue.

Configuring the Link: Step 6, Configuration Summary and Exit

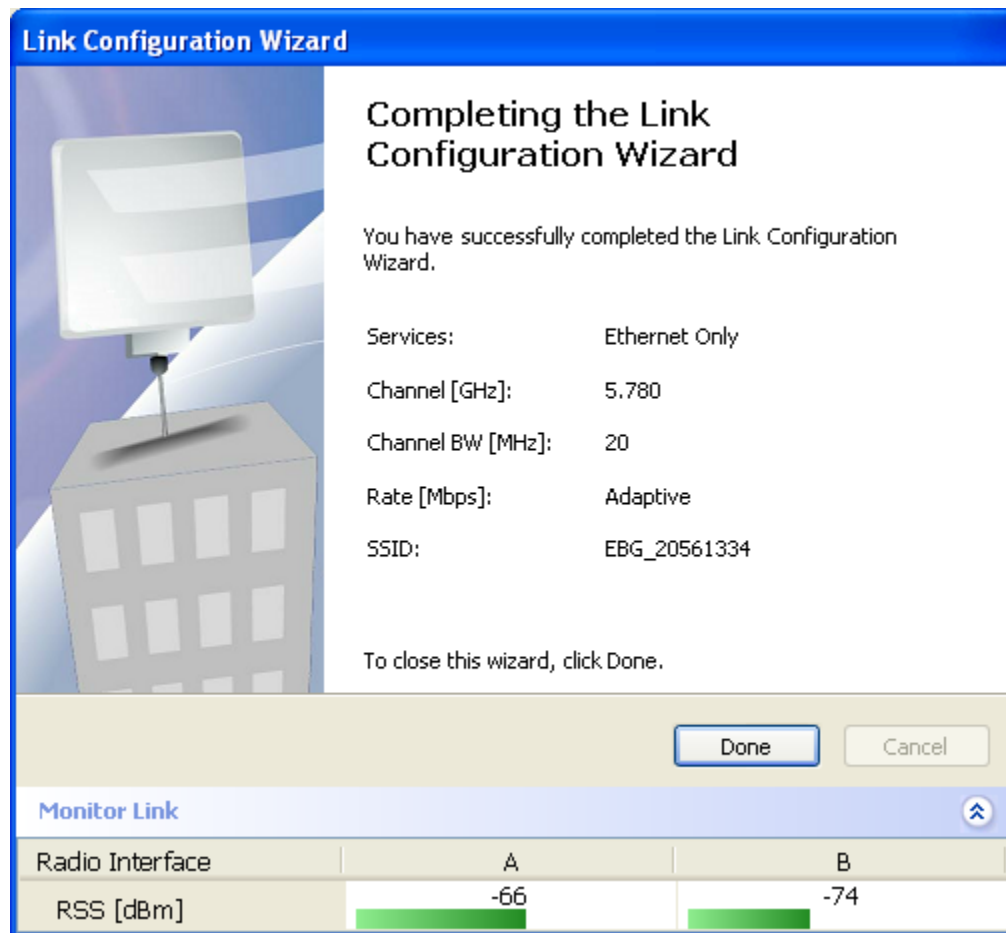

Figure 5-13: Configuration Wizard Exit Summary

Click **Done** to return to the main window.

The main window now reflects the configuration:

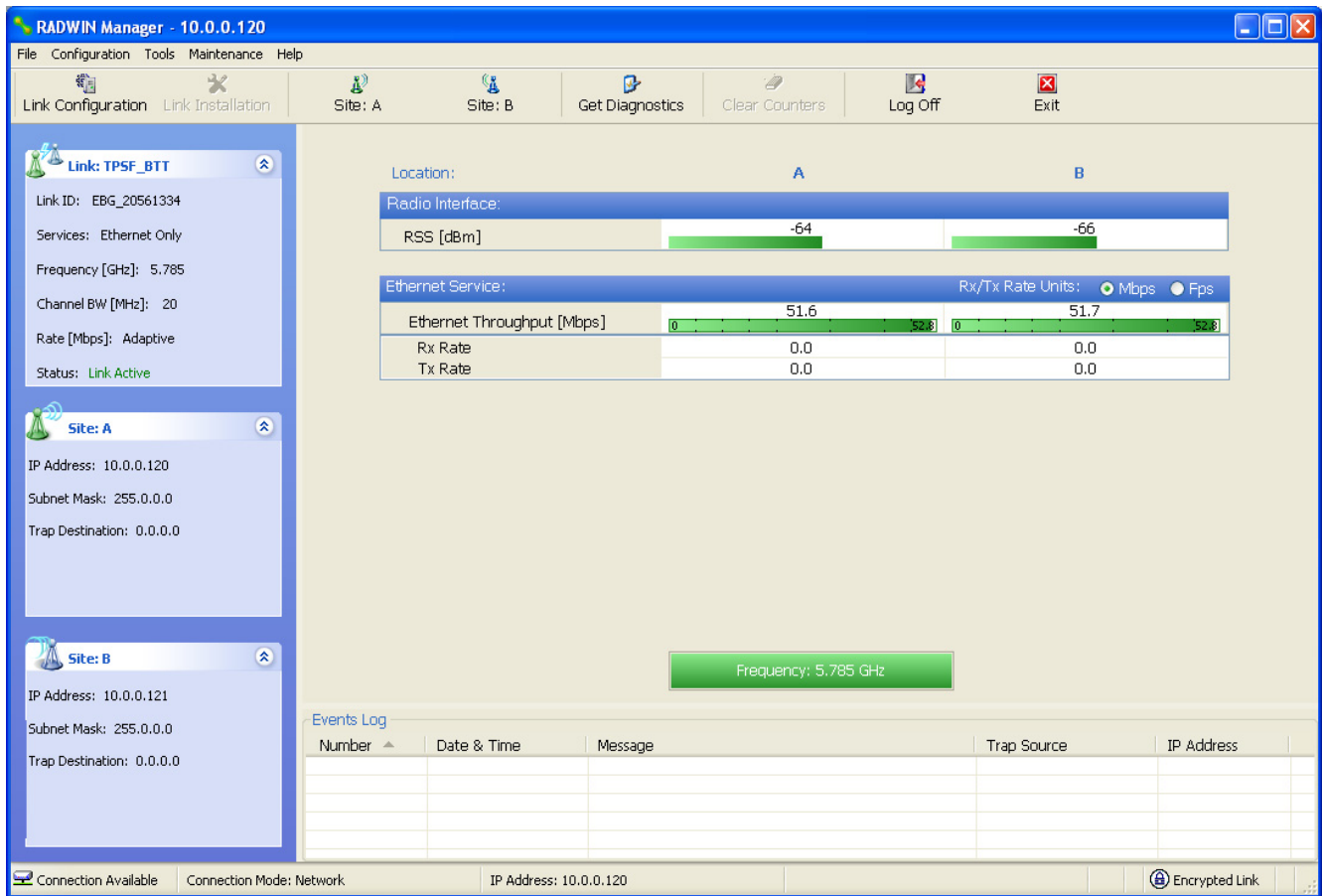

Figure 5-14: Main window of the manager after configuration

Site Configuration

The Site Configuration dialog panels are used to configure parameters, which may differ between both sides of the link.

The parameters configured using the Site Configuration dialog panels include (among others):

- System settings
- Air interface - Transmit (Tx) power and antenna
- Network management including VLAN
- Security settings
- Date and time
- Hub or Bridge mode

In addition, the Link Site Configuration panels include several information windows:

- Inventory - link hardware and software model details
- External alarms indicators

The Operations dialog offers a “doorway” to jump into installation mode reverting to factory settings.

The Site Configuration dialog has its own main menu with the following extra functionality:

- Backup configuration parameters to a text file
- Restore configuration from a previously backed up configuration file
- Enable/disable the site ODU buzzer
- Jump back into installation mode keeping current configuration settings

Configuring the Site

Editing the Configuration Parameters by Site

You can edit the configuration parameters for each site individually. The following functions are available from the left side of the dialog box.

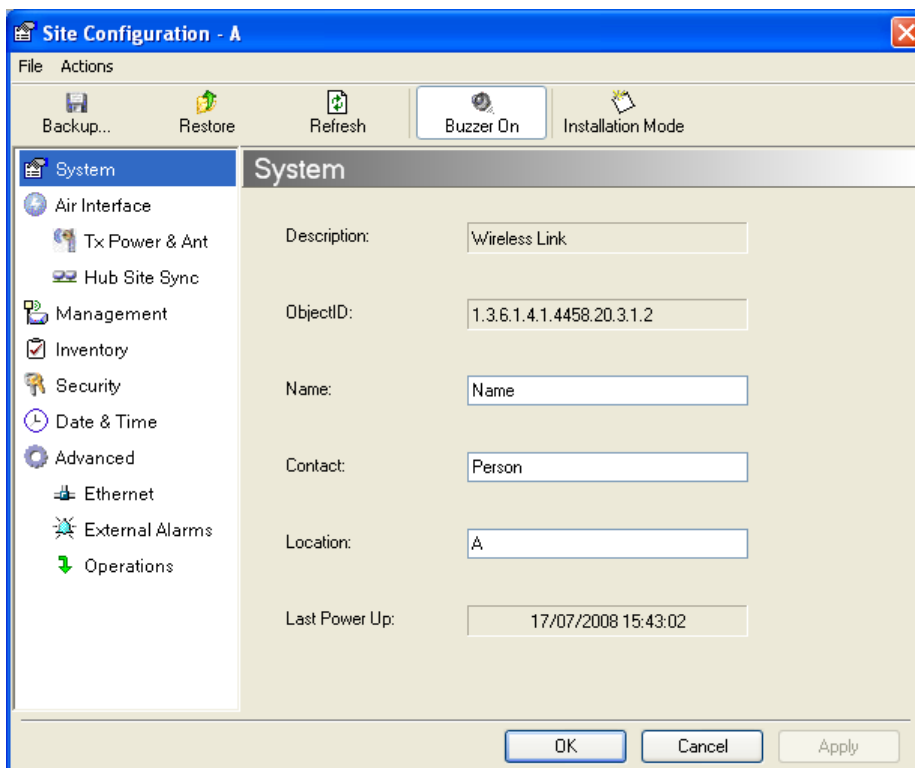

Figure 6-1: Configuration Dialog Box

Functions on the left of the dialog box:

- System** Edit the contact person and location details.
View the system details
- Air Interface** Change the transmit power, cable loss, antenna
type and settings
- Inventory** View the hardware and software inventory
(release numbers, model identification, MAC
address)
- Management** Configure the IP address, Subnet Mask, Default
Gateway, the Trap Destination and VLAN
- Security** Change the Community Values and the Link
Password
- Date and Time** Set the date and time of the link from an NTP
servers otherwise
- Advanced** Choose Hub or Bridge ODU mode, set the
Ethernet ports configuration, set the external
alarm inputs, restore factory settings

Functions at the top of the dialog box:

- Backup** Save the current configuration to an .ini file
- Restore** Restore the link configuration from the .ini file
created by the backup

Installation Mode	Return to Installation Mode for the entire link. Selecting the Mute check box before clicking the Install Mode button mutes the Beeper.
Mute	Mutes the alignment tone in installation mode. Reactivate the beeper during alignment.

➤ **To edit the Configuration Parameters:**

1. Click the required site button on the main tool bar of the RADWIN Manager

OR

Click **Configuration** from the main menu and choose a site to configure.

The Configuration dialog box opens (see [figure 6-1](#) above).

2. Choose the appropriate item in the left hand list to open a dialog box.
3. Click **Apply** to save changes.

In subsequent instructions, we will simply say “Choose a site to configure” on the understanding that the foregoing procedure is implied.

Viewing Air Interface Details

Click the Air Interface item in the left hand list. A window similar to the following appears:

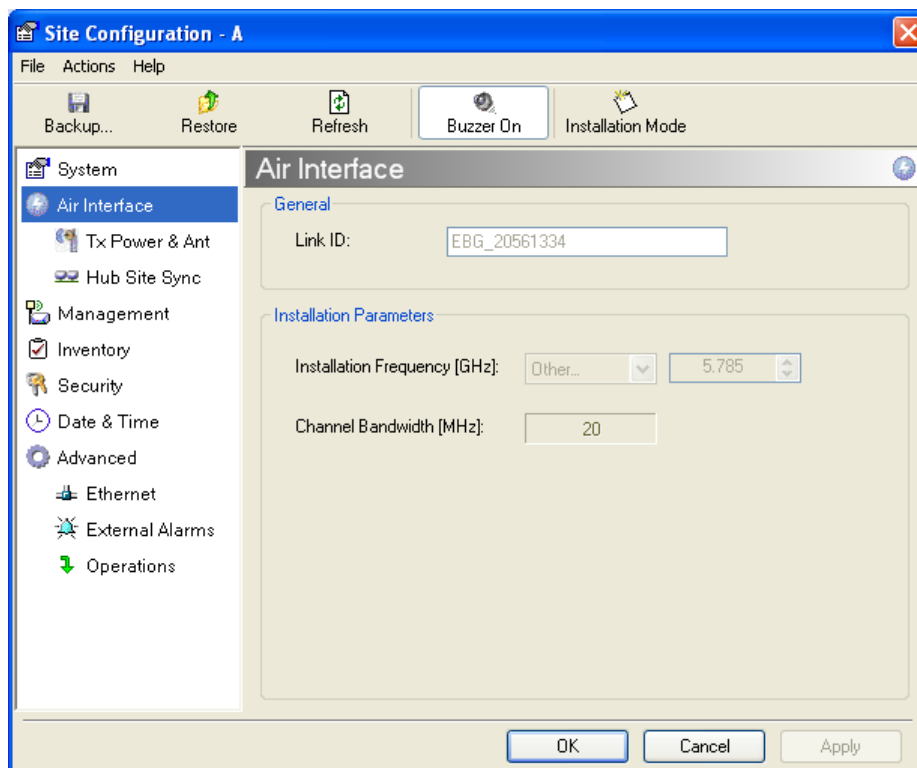

Figure 6-2: Air interface details

Changing the Transmit Power

Each site can have a different transmit power level.

➤ To change the Transmit Power:

1. Choose a site to configure.
The Configuration dialog box opens.
2. Choose Air Interface (see [figure 6-3](#)).
3. Choose the required Transmit (Tx) Power Level.
4. Click **Apply** to save the changes.

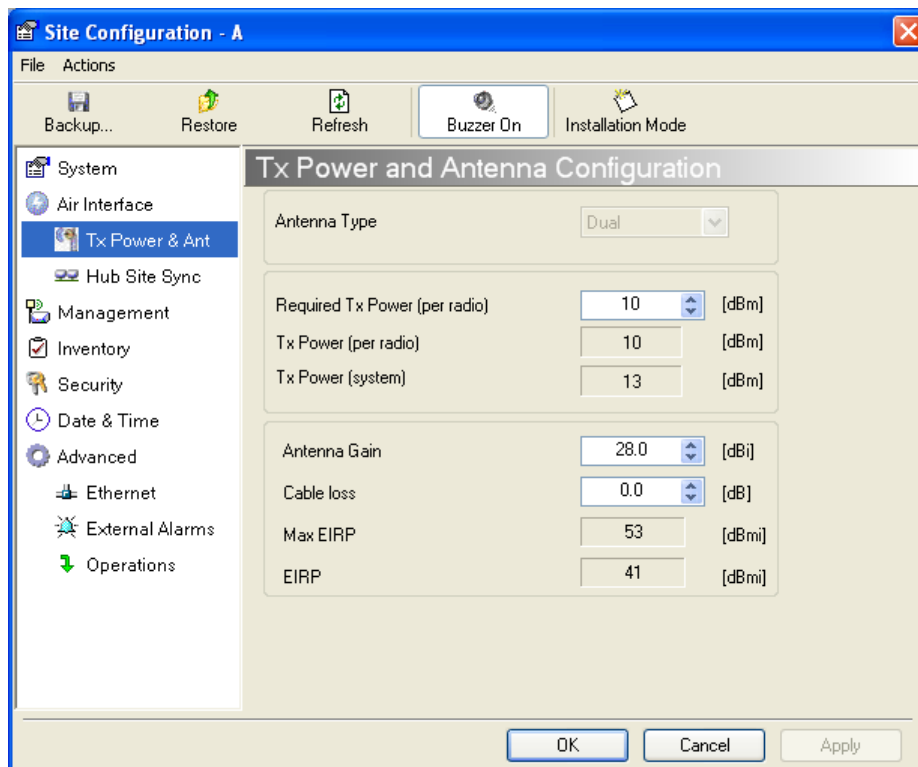

Figure 6-3: Changing the Transmit Power



The same considerations apply here as were noted in the Installation procedure on [page 4-23](#).

Site Management: IP Address and VLAN

Configuring the ODU Address

Each site must be configured separately, first site A then site B.

➤ To define the Management Addresses:

1. Choose a site to configure.

2. Choose a site to configure. If you are configuring both sites, choose site B first.
3. Choose **Management**.
4. Open the **VLAN** tab.
5. Check the **Enabled** box.
6. Enter a VLAN ID. Its value should be between 1 and 4094.

After entering the VLAN ID, only packets with the specified VLAN ID are processed for management purposes by the ODU. This includes all the protocols supported by the ODU (ICMP, SNMP, TELNET and NTP). The VLAN priority is used for the traffic sent from the ODU to the managing computer. Using VLAN for management traffic affects all types of management connections (local, network and over the air).

7. Enter a Priority number between 0 and 7.
8. Change the VLAN ID and Priority of the managing computer NIC to be the same as those of steps 6 and 7 respectively.
9. Click **Apply** or **OK**.

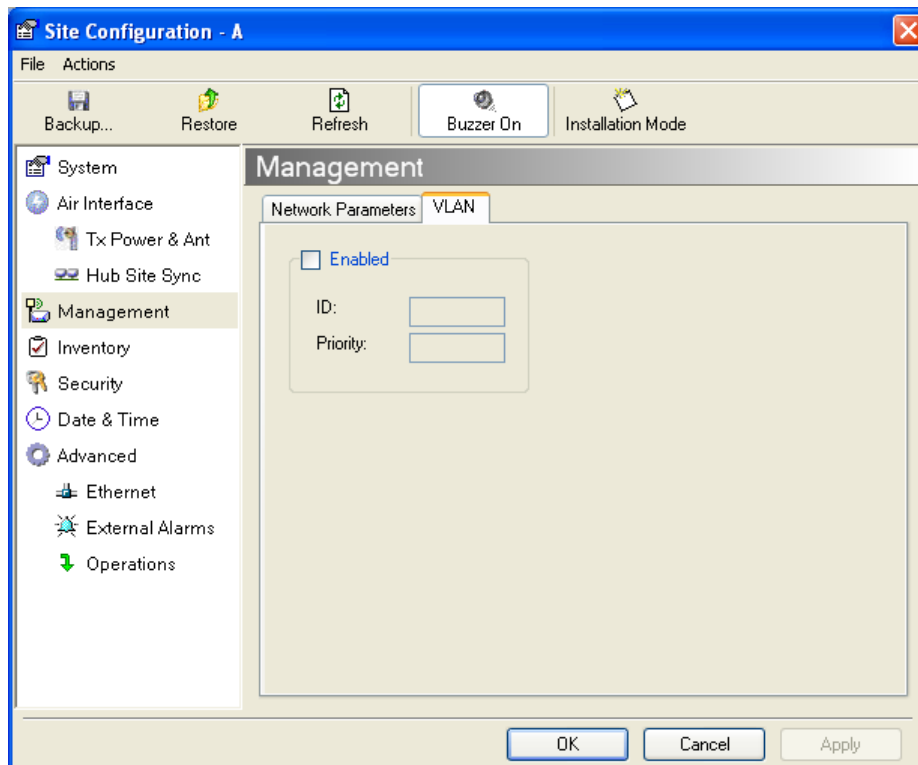

Figure 6-5: Configuring management traffic VLAN Settings



Caution

Changing this parameter causes the RADWIN Manager to immediately disconnect. To avoid inconvenience, you should verify the change by setting the VLAN only to one ODU, and only after verifying proper management operation, change the other ODU VLAN setting.

Lost or forgotten VLAN ID

If the VLAN ID is forgotten or there is no VLAN traffic connected to the ODU, then reset the relevant ODU.

During the first two minutes of connection to the ODU uses management packets both with and without VLAN. You may use this period to reconfigure the VLAN ID and priority.

Setting the Date and Time

The ODU maintains a date and time. The date and time should be synchronized with any Network Time Protocol (NTP) version 3 compatible server.

During power-up the ODU attempts to configure the initial date and time using an NTP Server. If the server IP address is not configured or is not reachable, a default time is set.

When configuring the NTP Server IP address, you should also configure the offset from the Universal Coordinated Time (UTC). If there is no server available, you can either set the date and time, or you can set it to use the date and time from the managing computer. Note that manual setting is not recommended since it will be overridden by a reset, power up, or synchronization with an NTP Server.



Note

The NTP uses UDP port 123. If a firewall is configured between the ODU and the NTP Server this port must be opened.

It can take up to 8 minutes for the NTP to synchronize the ODU date and time.

➤ To set the date and time

1. Determine the IP address of the NTP server to be used.
2. Test it for connectivity using the command (Windows XP), for example:
w32tm /stripchart /computer:216.218.192.202

You should get a continuous response of times, each a few seconds apart.

3. Choose a site to configure.

The Configuration dialog box opens.

4. Choose Date & Time:

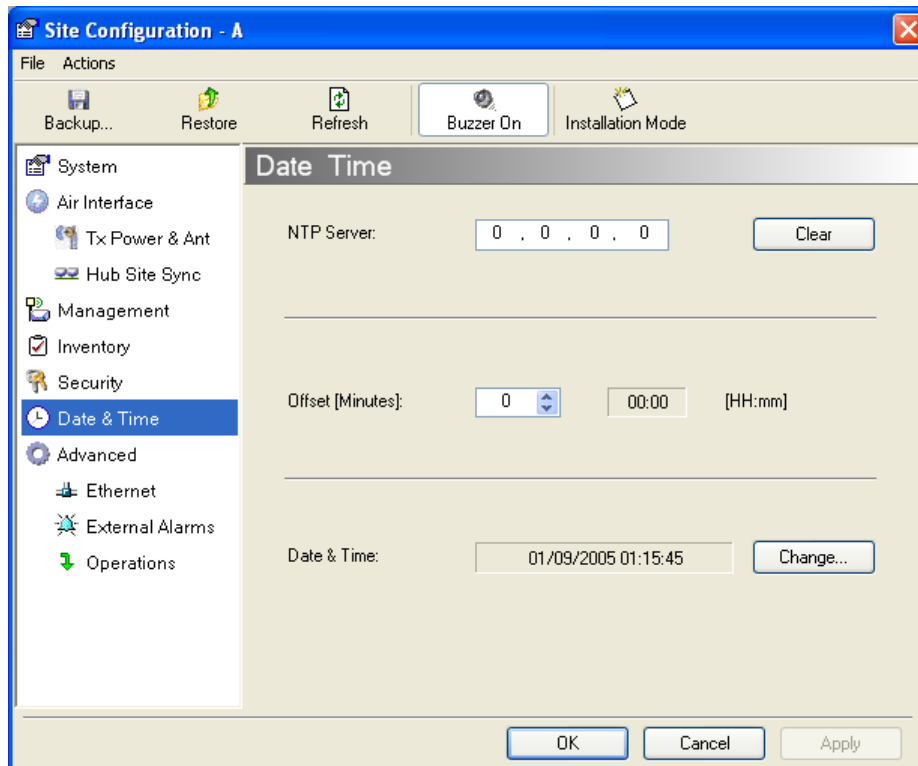

Figure 6-6: Date and Time Configuration

5. If entering an IP address for the NTP Server, click **Clear**, and then enter the new address.
6. Set your site Offset value in minutes ahead or behind GMT¹.
7. To manually set the date and time, click Change and edit the new values.

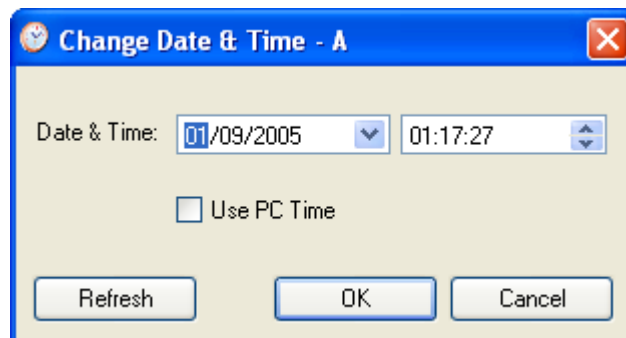

Figure 6-7: Change Date and Time

If you used an NTP Server, you will see a window like this:

1. Greenwich Mean Time

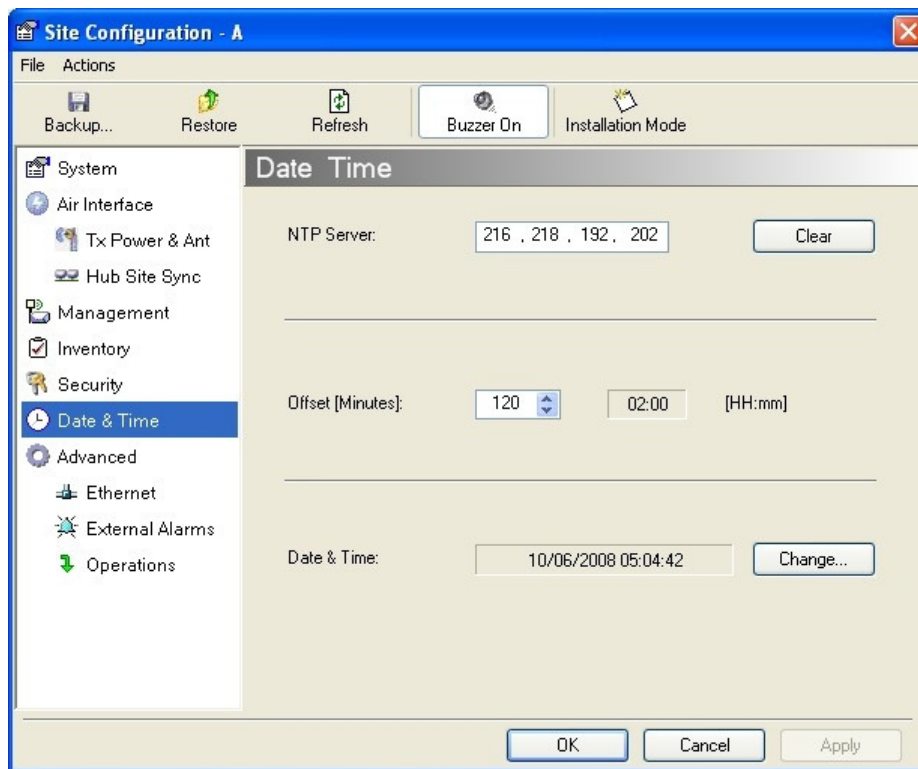

Figure 6-8: Date and Time configured from an NTP Server

8. Click **OK** to return to the Configuration dialog.

Ethernet Properties

Configuring the Bridge

Bridge configuration is required in various network topologies, such as protection (1+1) and ring applications. The bridge configuration parameters are located under the Advanced tab of the Site Configuration dialog box:

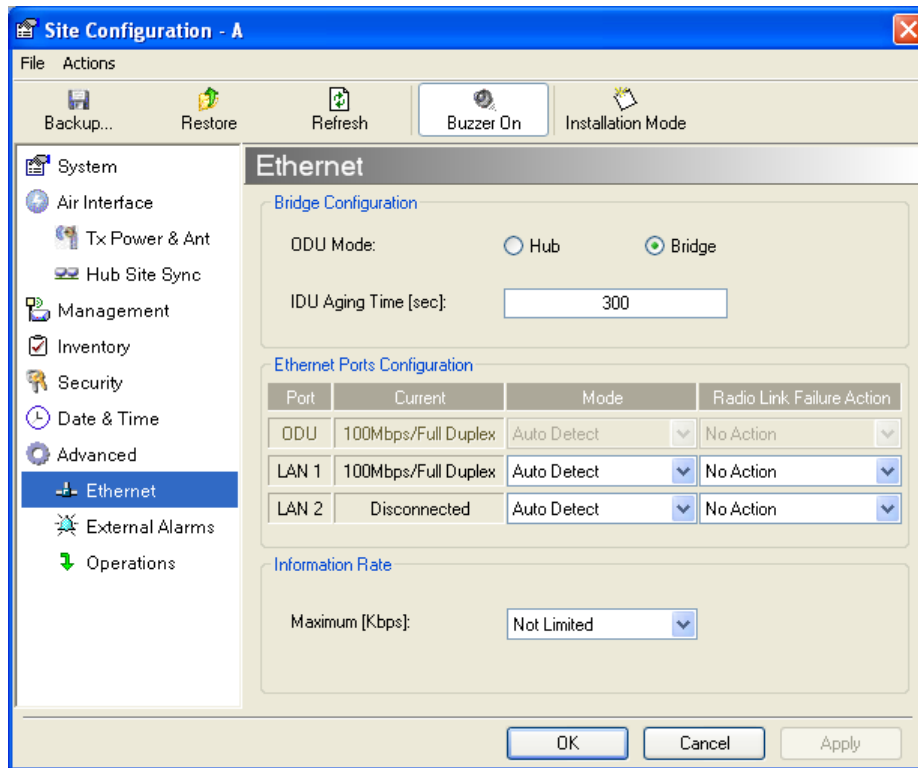

Figure 6-9: Bridge Configuration - Site Configuration dialog box

ODU Mode

This parameter controls the ODU mode with two optional values,

- Hub Mode - in Hub mode the ODU transparently forwards all packets over the wireless link.
- Bridge Mode - In Bridge mode the ODU performs both learning and aging, forwarding only relevant packets over the wireless link. The aging time of the ODU is fixed at 300 seconds.



Changing these modes requires system reset.

IDU Aging time

This parameter controls the IDU aging time.

The aging time parameter controls the time after which each MAC address is dropped from the MAC address learning table.

The default value is 300 seconds.



- Any change to these parameters is effective immediately.
- Each side of the link can be configured separately.

The following table shows the appropriate configuration for several common scenarios. Both link sites must be configured with the same parameter:

Table 6-1: ODU mode configuration for common

Scenario	ODU Mode	IDU Aging Time
Standard (Default) Configuration for Ethernet Applications	Bridge	300 sec
Rapid network topology changes where fast aging is required	Hub	1 sec
Ethernet Hub	Hub	N/A
Ethernet Bridge	Bridge	N/A

Configuring Ethernet Ports Mode

The ODU Ethernet port is configured to auto-detect by default and may not be changed.

The ODU Ethernet port mode is configurable for line speed (10/100BaseT) and duplex mode (half or full duplex).

An Auto Detect feature is provided, whereby the line speed and duplex mode are detected automatically using auto-negotiation. Use manual configuration when attached external equipment does not support auto-negotiation. The default setting is Auto Detect.



Caution

You should not reconfigure the port that is used for the managing computer connection, since a wrong configuration can cause a management disconnection or Ethernet services interruption.

➤ To configure the Ethernet Mode:

1. From the **Configuration** menu, choose the site to reconfigure.
The Site Configuration dialog box opens.
2. Click **Advanced | Ethernet**.
3. In the Ethernet Ports Configuration pane, use the drop-down menu to choose the configuration.

4. Click **Apply** to save the changes.

**Note**

It is possible to close the Ethernet service by disconnecting the Ethernet port.

If you close the port, you may subsequently be unable to access the device. If this should occur, a workaround is as follows:

- Connect the system from the remote site
 - Connect via other Ethernet port (of the IDU)
 - Power down the equipment and connect immediately after power up (the fastest way is to enter install mode)
-

Setting the Maximum Information Rate

The maximum Ethernet throughput of the link can be limited. The default setting is Not Limited (see [figure 6-9](#) above), where the highest information rate available for the link conditions and settings is used.

➤ To limit the Ethernet information rate:

1. From the **Configuration** menu, choose the site to reconfigure.
2. Click **Advanced | Ethernet**
The Configuration dialog box opens.
3. In the Information Rate pane, use the drop-down menu to choose the maximum Information Rate.
4. Choose **Other** to define the throughput with 1 Kbps resolution
5. Choose **Not Limited** for the highest information rate possible for the link conditions and settings
6. Click **Apply** to save the changes.

Displaying the Inventory

➤ To view the inventory data

1. Choose a site from the main menu.
The Configuration dialog box opens.
2. Choose Inventory ([figure 6-10](#)).

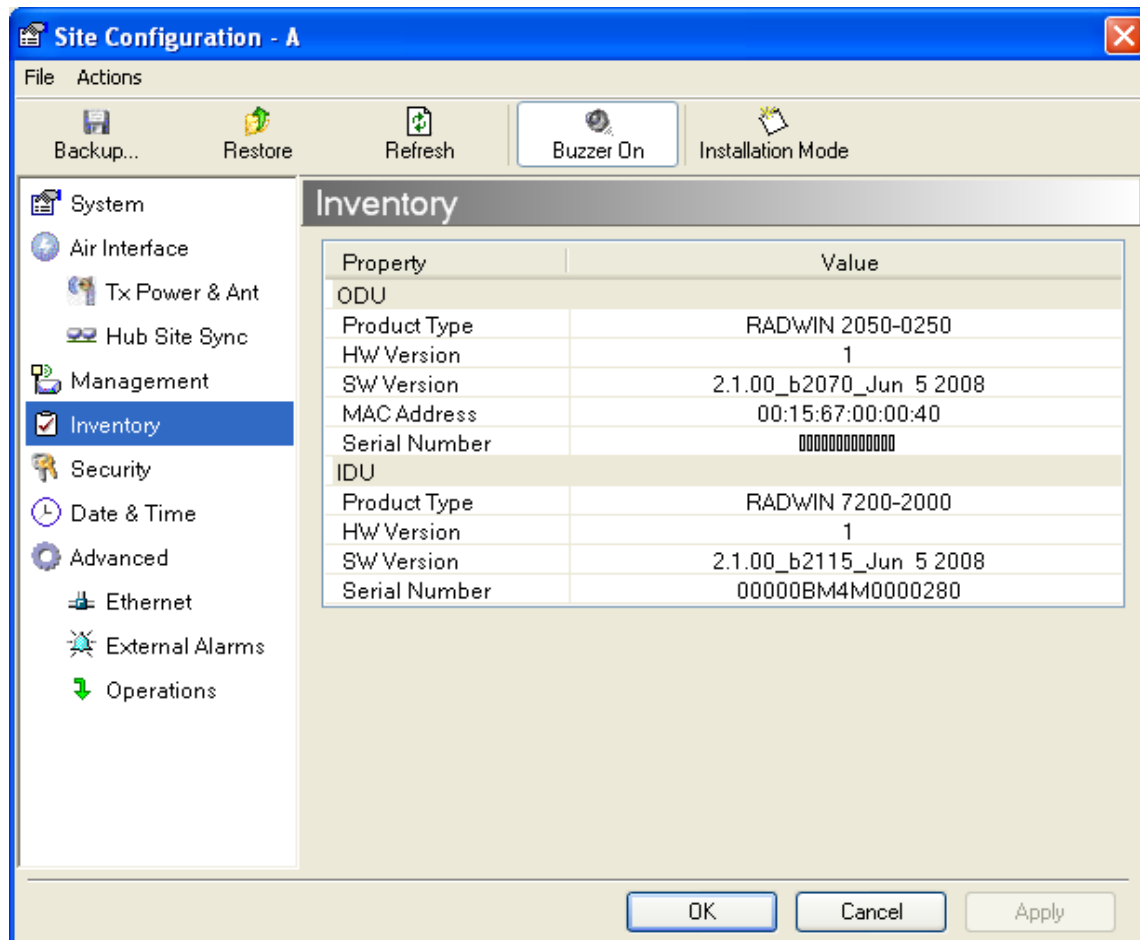

Figure 6-10: Inventory Screen

Security Features

The Security dialog enables you to change the Link Password and the SNMP Communities details:

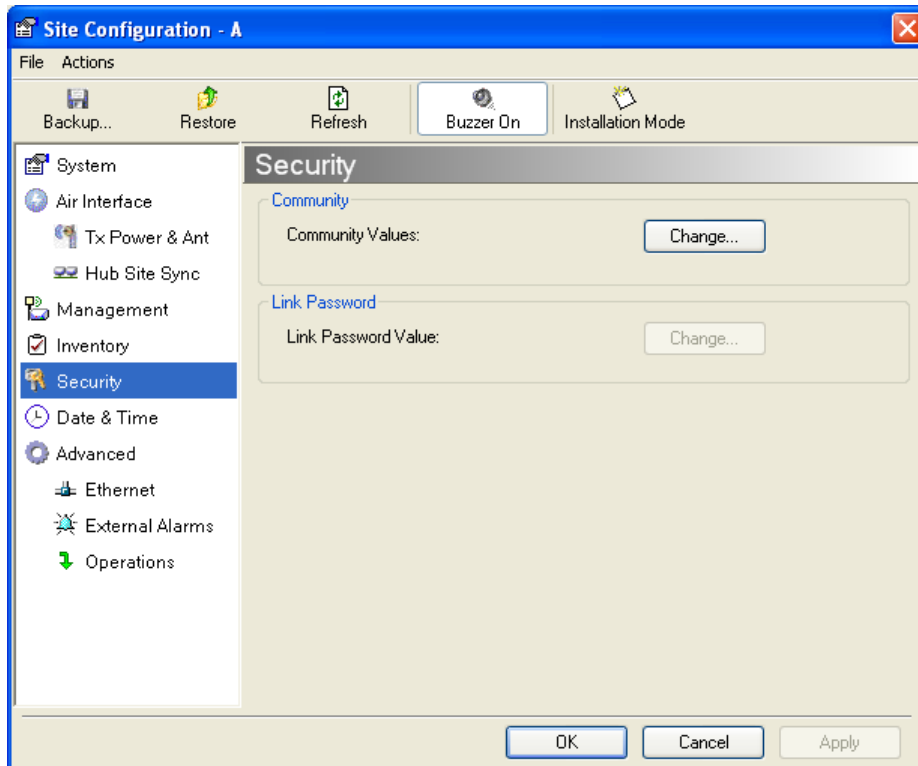

Figure 6-11: Available security features

Changing the Link Password

This item is only available when the link is down. Otherwise, it works the same way as the corresponding item on [page 4-16](#).

RADWIN Manager Community Strings

The ODU communicates with the application using SNMPv1 protocol. The protocol defines three types of communities:

- Read-Only for retrieving information from the ODU
- Read-Write to configure and control the ODU
- Trap used by the ODU to issue traps.

The Community string must be entered at login. The user must know the password and the correct Community string to gain access to the system. A user may have read-only privileges.

It is not possible to manage the ODU if the read-write or the read Community values are forgotten. A new Community value may be obtained from RADWIN Customer Support for the purpose of setting new Community; the serial number or the MAC address of the ODU must be supplied.



Note

The RADWIN Manager uses the Read Community strings **public** for the site A ODU and **public-remote** for the site B ODU. It uses Write Community strings **netman** for the site A ODU and **netman-remote** for the site B ODU. These are the factory defaults.

The read-write Community strings and read-only Community strings have a minimum of five alphanumeric characters. (**bru1** and **bru4097** are not permitted). Changing the trap Community is optional and is done by clicking the check box.

Editing Community Strings

The Community change dialog box is available from the **Configuration | Security** tab. Both read-write and read-only communities must be defined.

On logging on for the first time, use the following as the current Community:

- For Read-Write Community, use *netman*.
- For Read-Only Community, use *public*.
- For Trap Community, use *public*

➤ To change a Community string:

1. From the Configuration dialog box, choose the Security tab.
2. Type the current read-write Community (default is *netman*).
3. Choose the communities to be changed by clicking the check box.
4. Type the new Community string and re-type to confirm.
5. Click **OK** to save.

The screenshot shows a dialog box titled "Change Community - A". At the top, there is a section "Enter current Read-Write Community:" with a search icon and an empty text field. Below this are three sections, each with a checked checkbox and a title: "Read-Write Community", "Read-Only Community", and "Trap Community". Each section contains "New:" and "Confirm:" text labels followed by empty text input fields. At the bottom, there is a checked checkbox for "Hide characters", a "Forgot Community..." button, and "OK" and "Cancel" buttons.

Figure 6-12: Changing the Community String

Forgotten Community string

If the read-write Community string is unknown, an alternative Community key can be used. The alternative Community key is unique per ODU and can be used only to change the Community strings. The alternative Community key is supplied with the product, and should be kept in a safe place.

If both the read-write Community and the alternative Community key are unavailable, then an alternative Community key can be obtained from RADWIN Customer Support using the ODU serial number or MAC address. The serial number is located on the product label. The serial number and the MAC address are displayed in the Site Configuration inventory tab.

When you have the alternative Community key, click the **Forgot Community** button and enter the Alternative Community key (figure 6-13). Then change the read-write Community string.

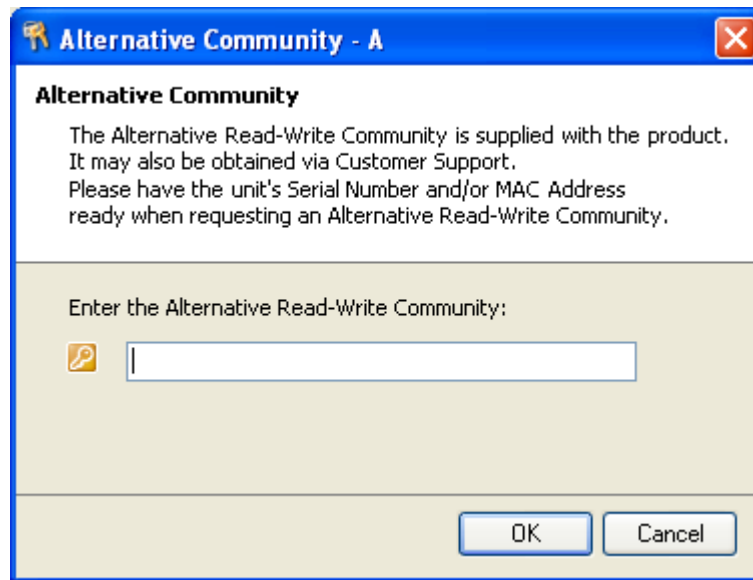

Figure 6-13: Alternative Community Dialog box

Muting the alignment tone

The ODU alignment tone becomes audible as soon as power is supplied, and continues until the ODUs are aligned and the link established.

It is possible to mute the tone during regular operation of the link. It must be enabled when performing the alignment procedure.

➤ To mute the alignment tone:

1. Choose a site.
2. The Configuration dialog box opens.
3. In the Configuration dialog box, click the **Buzzer** button. The button toggles between on and off.

The tone is disabled.

➤ To restore the alignment tone:

1. Choose a site.
The Configuration dialog box opens.
2. In the Configuration dialog box, click the **Buzzer** button. The button toggles from on to off. The tone is enabled.

Setting External Alarm Inputs

The IDU-C has two external alarm inputs and two external alarm outputs in the form of dry-contact relays. The Alarm interface is located on the front panel of the IDU-C and is a 25-pin D-type female connector. see [IDU-C Alarm Connector](#) on page [B-3](#), for wiring specifications and pinout. The user enables or disables each of the alarms and can configure the alarm

description text that appears in the alarm trap. The ODU sends the alarm within less than a second from actual alarm trigger.

➤ **To set the external alarm inputs:**

1. Open the Site Configuration Alarms configuration by clicking **Configuration | Advanced**.

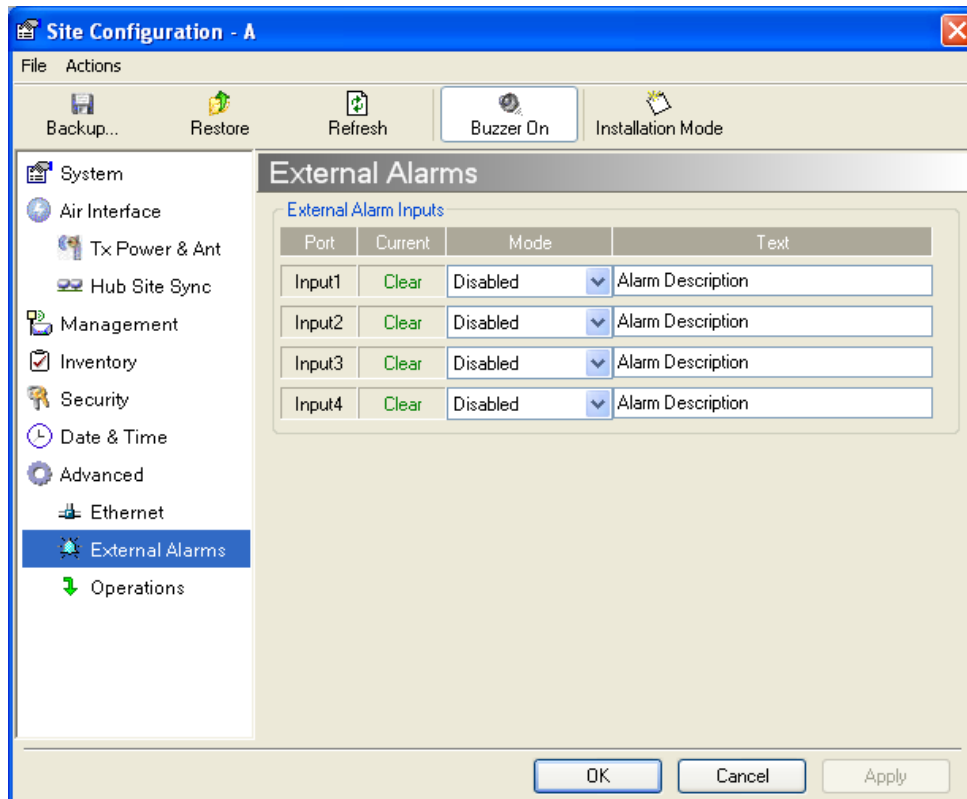

Figure 6-14: External Alarm Configuration

2. Choose an alarm and set its mode to Enabled or Disabled
3. Enter a description of the alarms in the text field.
4. Click **Apply** to save.
5. Click **OK** to exit from the dialog.

Managing Configuration Files

Backup Configuration to a File

RADWIN Manager allows you to backup configuration parameters of the local and remote units to the managing computer as **.ini** files. Each site is backed up in a separate **.ini** file.

➤ **To save the configuration in a file:**

1. Choose a site to back up.
The Configuration dialog box opens.

2. Click **Backup**.
3. In the Save As dialog box, indicate in which folder and under what name configuration file is to be saved, and click **Save**.

Restoring a Configuration File

Configuration files (*.ini) can be uploaded from the managing computer. Such configuration files can be distributed to other units that use the same configuration.

➤ **To restore a configuration file:**

1. Choose a site to restore (from a previous backup).
The Configuration dialog box opens.
2. Click **Restore**.
3. From the Open dialog box choose *.ini file to upload and click **OK**.



Caution

Backup files are specific to a site (IDU / ODU pair and Link ID).

Do not restore a backup configuration file to a site other than that from which it was originally taken.

Resetting

You may reset the link, preserving the current configuration, or reset to factory defaults.



Caution

Resetting the link causes service disconnection.

To maintain the connection between the managing computer and the link, first reset Site B.

➤ **To reset the link preserving current configuration:**

1. From **Maintenance** on the main window, reset the remote unit.
2. From **Maintenance** on the main window, reset the local unit.

➤ **To reset to Factory Defaults**

1. Choose either of the sites.
The Configuration dialog box opens.
2. Choose **Operations** in the Configuration dialog box.
3. Click the **Restore Defaults** button.
A message box asking if you want to restore factory default appears.
4. Click the check box if you want to keep the current IP address settings.
5. Click **Yes** to continue.

Configuration with Telnet

A Telnet terminal can be used to configure and monitor the RADWIN 1000/2000.

To start a Telnet session, use **telnet <manager IP>**.

For example, if you run Telnet as follows,

telnet 10.0.0.120

you will be asked for a user name and password.

The login user name/password is identical to the Community strings; Read allows display only, Read/Write allows display and set commands.

Supported Telnet commands are shown in [table 6-2](#). Note that some of the commands are model-specific. For example, TDM commands will not apply to Ethernet only and PoE based links.

Table 6-2: Telnet Commands

Command	Explanation
display inventory	Displays ODU product name, Name, Location, hardware and software revisions, uptime, MAC address, IDU product name, IDU software and hardware revisions
display management	Displays IP, Subnet, Gateway, Traps table
display link	Displays State, Link ID, Channel BW, RSS, TSL, Frequency/ACS, DFS, Rate/ARA, Distance
display Ethernet	Displays Bridge Mode, Aging time, Port table (State, Status and action)
display tdm	Displays Clock Mode, Master Clock Mode, Current Clock, Quality[1], TDM table (Line status, Error Blocks)
display ntp	Displays Time, Server and Offset
set ip <ipaddr> <subnetMask> <gateway>	Set the ODU IP address, subnet mask and gateway The user must reset the ODU after the command completion
display PM <interface:AIR,LAN1,LAN2,TDM1, TDM2,TDM3,TDM4> <interval:current,day,month>	Shows the performance monitor tables for each interface according to user defined monitoring intervals
set trap <index:1-10> <ipaddr> <port:0-65535>	Set a specific trap from the traps table (set trap 3 10.0.0.133 162)
set readpw <oldpasswd> <passwd>	Set the read access password (Read Community)
set writepw <oldpasswd> <passwd>	Set the read-write access password (Read-Write Community)
set trappw <oldpasswd> <passwd>	Set the trap Community string
set buzzer <mode:0=OFF,1 =ON>	Toggle the buzzer mode (0 – off, 1 – on)

Table 6-2: Telnet Commands (Continued)

Command	Explanation
set tpc<power:Value between minimal TX power, and maximal TX power>	Set the ODU transmit power. If a wrong value is entered, both min and max values shall be displayed in the error reply
set bridge <mode:0=Bridging OFF,1=Bridging ON >	Set the ODU bridge mode (0 – off, 1 – on)
set name <new name>	Set the name of the link
set location <new location>	Set the name of the location
Set contact <new contact>	Set the name of the site manager
set Ethernet <>port:MNG,LAN1,LAN2> <mode:AUTO,10H,10F,100H,100F,DIS ABLE>	Set the mode and speed of each ethernet port
Reboot	Reset both the IDU and the ODU. The user shall be prompt that the command will reset the card and that he has to reconnect the telnet session after TBD seconds.
Help	Displays the available commands

figure 6-15, below, shows the available Telnet commands via the Help command.

```
Hello admin, welcome to ODU Management CLI!
+-----+
Software Revision      2.1.00_b2070_Jun 5 2008
+-----+

admin@10.0.0.120-> Type "help" for help.

admin@10.0.0.120-> help
display inventory
display management
display link
display ethernet
display tdm
display ntp
display PM <interface:AIR,LAN1,LAN2,TDM1,TDM2,TDM3,TDM4>
           <interval:current,day,month>
set ip <ipaddr> <subnetMask> <gateway>
set trap <index:1-10> <ipaddr> <port:1-65535>
set readpw <writePasswd> <newPasswd>
set writepw <writePasswd> <newPasswd>
set trappw <writePasswd> <newPasswd>
set buzzer <mode:0=OFF,1=ON>
set tpc <power:Value between minimal TX power, and maximal TX power>
set bridge <mode:0=Bridging OFF,1=Bridging ON>
set name <new name>
set location <new location>
set contact <new contact>
set ethernet <port:MNG,LAN1,LAN2> <mode:AUTO,10H,10F,100H,100F,DISABLE>
reboot
help

Command "help" finished OK.
```

Figure 6-15: Telnet Management Screen

Monitoring and Diagnostics

The RADWIN Manager application enables you to monitor the link, as well as perform diagnostic operations such as loopback tests.

This chapter covers:

- Retrieving link information
- Link compatibility issues
- Reinstalling and realigning a link
- Performance monitoring
- Troubleshooting
- Replacing an ODU
- Restoring to factory setup

Retrieving Link Information (Get Diagnostics)

The Get Diagnostics feature collects and writes all link and Manager information (from both sites) into a text file. The file information can be used for diagnostics and should be sent to RADWIN Customer Support to speed up assistance.

The following table lists link and system information that can be monitored.

Table 7-1: Get Diagnostics Data and Description

Data	Description
System Data	General information about the system
Link Information	Information about the link properties
Events Log	List of recent system events
Site Configuration	Data about the site parameters
Active Alarms	List of active alarms
Performance Monitor	Network performance data over defined time periods
Monitor	Detailed event data record

➤ **To get diagnostics**

1. On the Help menu, choose **Get Diagnostic Information**.

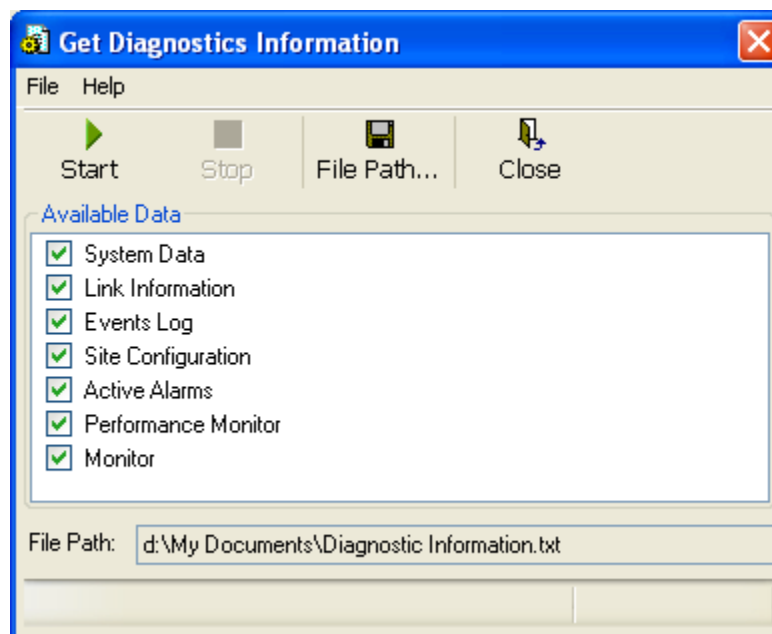

Figure 7-1: Get Diagnostics Dialog Box

2. Select or deselect the data options. If the file is to be sent to RADWIN Customer Support leave all options checked.
3. Click **File Path** to specify the folder in which you want to save the file and then click **Start** to save the information.

The file is saved in the specified folder as **Diagnostics Information.txt**

Link Compatibility

Link Compatibility indicates the version compatibility using software traps. As new hardware or software is added to existing networks compatibility issues may arise. An incompatibility issue is indicated to the user by a change of color of the Link Status box on the Main Menu screen. Trap messages in the events Log indicate the problems or limitations and suggest upgrades when appropriate.

The following Link Status messages are given:

fullCompatibility - different software versions were detected that are fully compatible. The message indicates that an upgrade is available.

restrictedCompatibility - different software versions were detected that operate correctly. However, new features are not supported

softwareUpgradeRequired - different software versions were detected allowing limited operation. The message is, that a software upgrade required.

versionsIncompatibility - different software versions were detected that are incompatible. You need to perform local upgrades.

Table 7-2: Link Compatibility Trap Messages

Link State	Link State text	Link Status Color	Site Description	Site Desc. Color	Link Status Color
fullCompatibility	Active	Green	SW Upgrade Available	Yellow	Green
restrictedCompatibility	Active - SW Version mismatch	Magenta (Same as authentication error)	SW Upgrade Recommended	Yellow	Magenta (Same as authentication error)
softwareUpgradeRequired	Active – SW Upgrade Required	Brown (Major)	SW Upgrade Required	Yellow	Brown (Major)
versionsIncompatibility	Not Active - SW Upgrade Required	Red	Local SW Upgrade Required	Yellow	Red

Reinstalling and Realigning a Link

It may be necessary to reinstall the link if the ODUs need to be realigned.



Note

Activating Install Mode causes both sites to go into install mode, causing disruption in service for approximately fifteen seconds.

➤ **To reinstall the link:**

1. Choose a site.
The Configuration dialog box opens.
2. In the Configuration dialog box, click the **Install Mode** button.
A message box asking if you want to enter install mode appears.
3. Click **Yes** to continue.
The system enters Install mode and the alignment tone becomes audible.
4. Realign the ODUs and start the Installation wizard (see chapter 4).

The Link Budget Calculator

The Link Budget Calculator is part of the RADWIN Manager software and is found in the Help menu. This useful utility enables you to calculate the expected performance of the wireless link and the possible configurations for a specific link range including antenna size, cable loss and climate conditions. For full details, see appendix D.

Performance Monitoring

RADWIN 1000/2000 Performance Monitoring constantly monitors traffic over the radio link and collects statistics data for the air interface and Ethernet ports. It does so continuously, even when the RADWIN Manager is not connected.

Two types of logs are recorded:

- **Monitor Log** that records statistics on traffic rate and radio signal strength.
- **Events Log** that records when the rates fall above or below a predefined threshold.

Both the statistics Monitor log and events log can be saved as TXT files.

The Monitor Log

The Monitor Log records performance statistics for predefined intervals. You can save the monitor log to a text file, as well as display the information in an on-screen report.

Saving the Monitor Log

You can save the recorded Monitor Log statistics to a text file.

➤ **To save the monitor log:**

1. From the **Tools** menu, choose **Preferences**.
The Preferences dialog box appears:

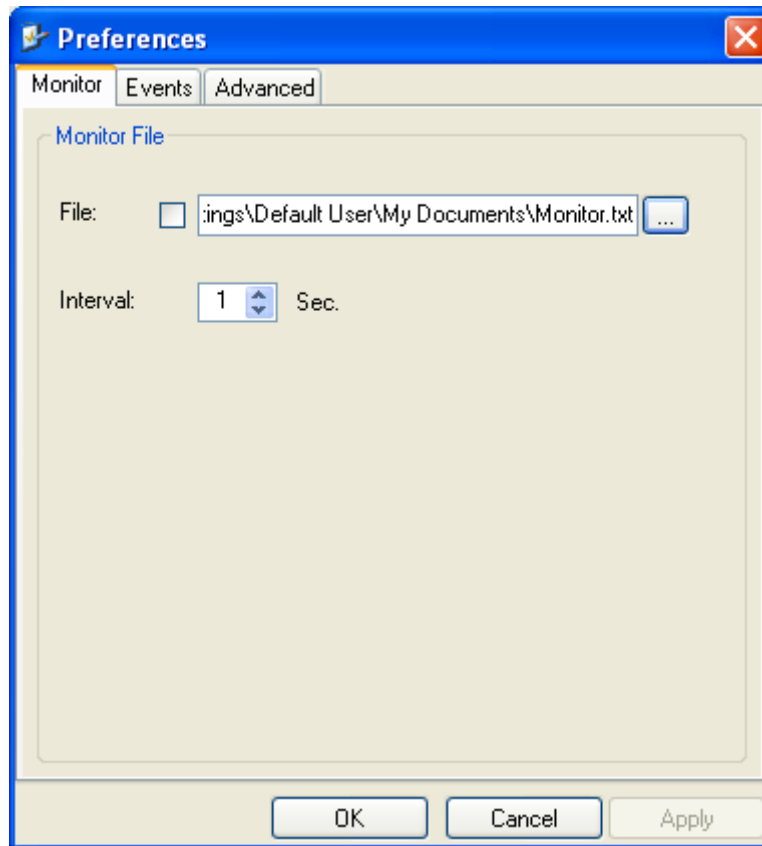



Figure 7-2: Preferences dialog box

2. Click the **Monitor** Tab.
3. Select the file to save.
4. Click the check box to open the file for saving.
5. Click the  button and in the Select File dialog box indicate in which folder and under what name the monitor log file is to be saved.
6. Set the time interval for adding data to the file.
7. Click **OK** to save the file.

Viewing Performance Reports

The Performance Monitor Report displays performance views of each of the interfaces¹.

➤ To obtain performance monitoring reports:

1. From the main menu, choose **Tools | Performance Monitoring Report ...**

You are presented with the following window:

1. Ethernet performance is not collected from PoE devices.

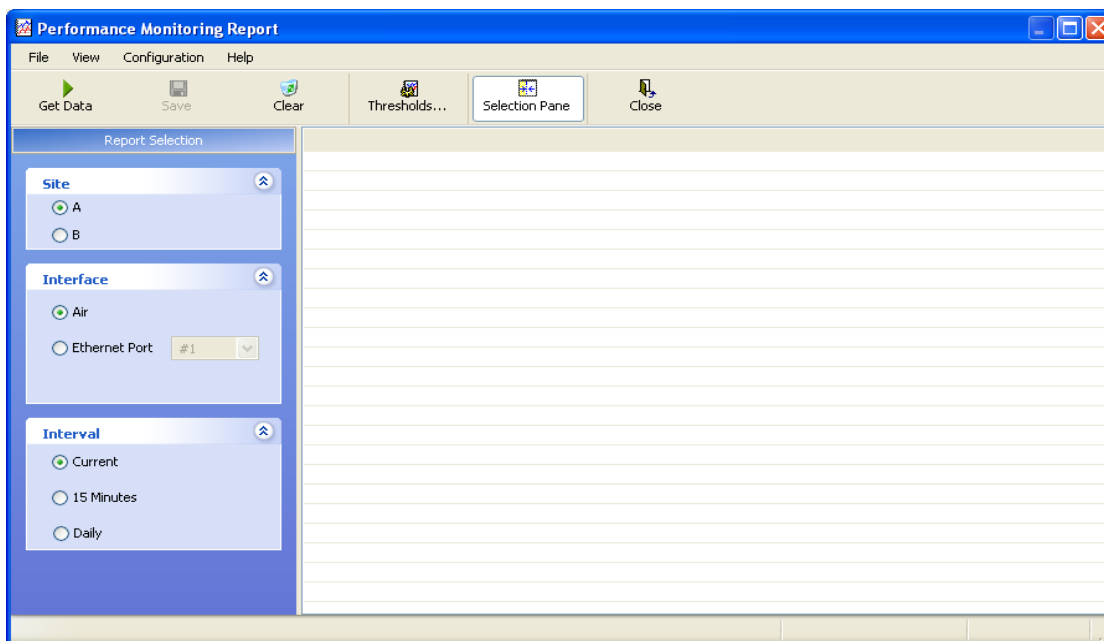

Figure 7-3: Basic Performance Monitoring Report

2. Choose a report type from the left panel and click the **Get Data** toolbar button. For example, if you choose Site A, Air and Current, you will be offered a report looking like this:

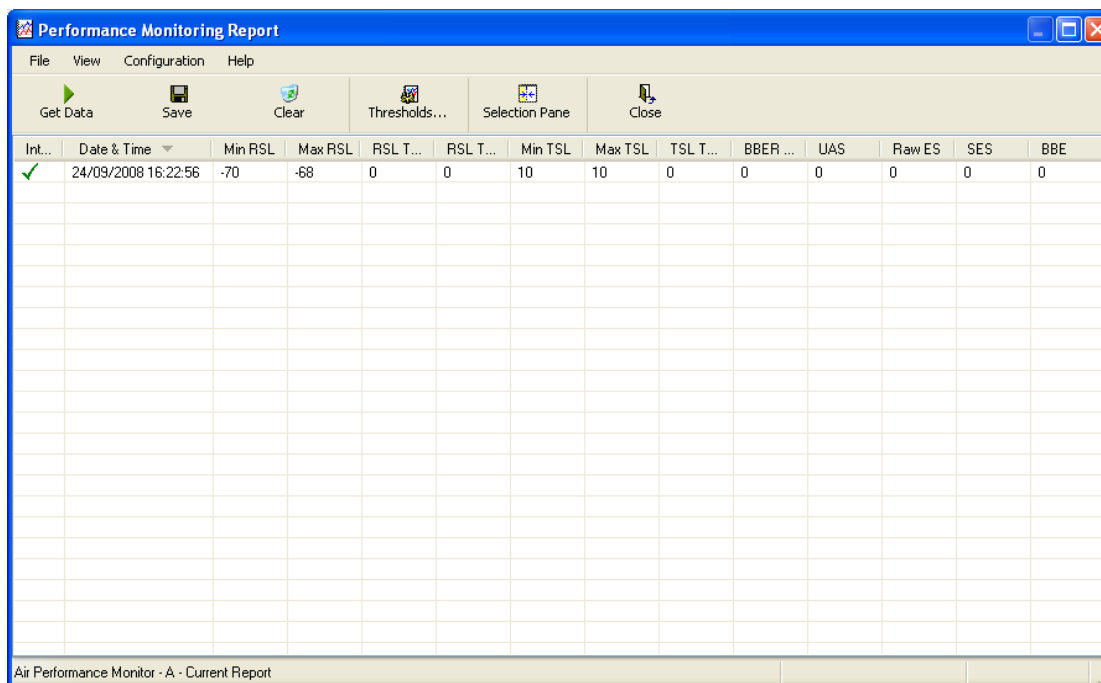

Figure 7-4: A typical Performance Monitoring Report

You can click the **Selection Pane** icon to toggle the side panel on or off. The other reports look similar. Here is a detailed description of the reports and their fields:

Several performance data occurrences are collected for each of the interfaces (ES, SES, and UAS), as well as Specific data per Interface type (e.g., TX and RX bytes for Ethernet). For the Air Interface, user defined thresholds data are collected. Refer to [table 7-3](#) and [table 7-4](#), in [Performance Monitoring Report Toolbar](#) below.

Data is collected and selectively displayed based on three time intervals as selected by the **Interval** radio buttons:

- Current (t=0)
- 15 minutes Intervals
- Daily

Table 7-3: Explanation of performance data

Data type	Reported Value	Explanation
Generic PM Data	UAS – Unavailable Seconds	Seconds in which the interface was out of service.
	ES – Errored Seconds	The number of seconds in which there was at least one error block. Note that the notation of an error block is different per interface.
	SES – Severe Errored Seconds	The number of seconds in which the service quality was low (the quality is different per type of interface and determined by the BBER threshold per interface).
	BBE – Background Block Error	The number of errored blocks in an interval.
	Integrity	A flag indicating that the data was valid. Note that the Performance Monitoring data is not valid if not all the values were stored (e.g., due to clock changes within the interval or power up reset).
Air Interface PM Data	Max RSL	The maximum of the receive signal level (measured in dBm).
	Min RSL	The minimum of the receive signal level (measured in dBm).
	Max TSL	The maximum of the transmit signal level (measured in dBm).
	Min TSL	The minimum of the transmit signal level (measured in dBm).
	RSL Threshold 1	The number of seconds in which the RSL was below the specified threshold.
	RSL Threshold 2	The number of seconds in which the RSL was below the specified threshold.
	TSL Threshold	The number of seconds in which the RSL was above the specified threshold.
	BBER Threshold	The BBER Threshold value counts the number of seconds in which the Background Block Error Ratio (BBER) exceeded the specified threshold.
Ethernet Interface PM Data	Received Bytes	The number of Megabytes received at the specified port within the interval
	Transmitted Bytes	The number of Megabytes transmitted at the specified port within the interval.

Performance Monitoring Report Toolbar

You can use the toolbar to perform the actions described in the following table:

Table 7-4: Action of the toolbar buttons

Command Button	Action
Get Data	Gathers current performance monitoring data.
Save	Save current performance monitoring data to a file
Clear	Clear current performance monitoring data.
Thresholds	Set Air Interface Thresholds
Close	Closes the active alarm window.

Setting Air Interface Thresholds

Use the Thresholds button on the Monitoring Performance Report toolbar to set the Air Interface Thresholds:

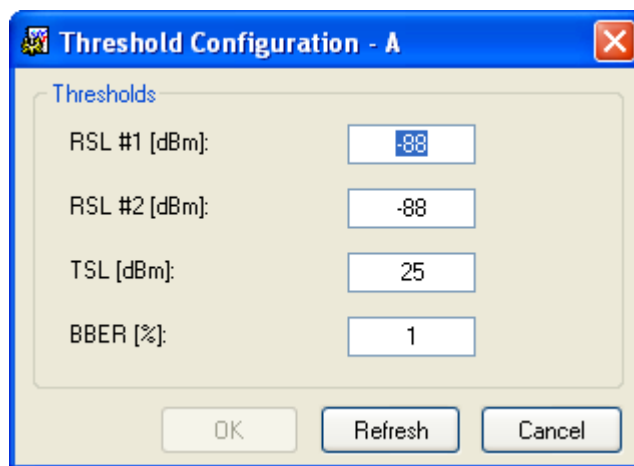

Figure 7-5: Threshold configuration dialog box

BBER Threshold

This parameter counts the seconds during which the radio performance is below a user specified threshold. The threshold is measured as a percentage. The threshold can be set from 0.1% up to 50%.

For links with Ethernet only service, 8% threshold is recommended. If there are no problems during the interval, then for that threshold, the recommended BBER value should be 0. Since the system provides a lossless Ethernet service, there is throughput degradation in case of interference. The degradation is proportional to the BBER.

RSL Threshold

RSL Threshold can also be used as an indicator of problems in the radio channel. You can check the RSS by from the Link Budget Calculator results

during installation. A value of -5dB from the current RSS is recommended as a threshold.

The Events Log

The Events Log records system failures, loss of synchronization, loss of signal, compatibility problems and other fault conditions and events.

Alarms (traps) are displayed in the Events Log in the lower panel of the main window. The Events Log may be saved as a text file.

The Events Log includes the following fields:

- ⇒ Sequential number (ID)
- ⇒ Date and time stamp
- ⇒ Message
- ⇒ Trap source
- ⇒ IP address of the ODU that initiated alarm.

For complete information about traps and alarms see appendix F, [MIB Reference](#), [table F-3](#).

The events are displayed in the Events Log in the lower part of the RADWIN Manager main window:

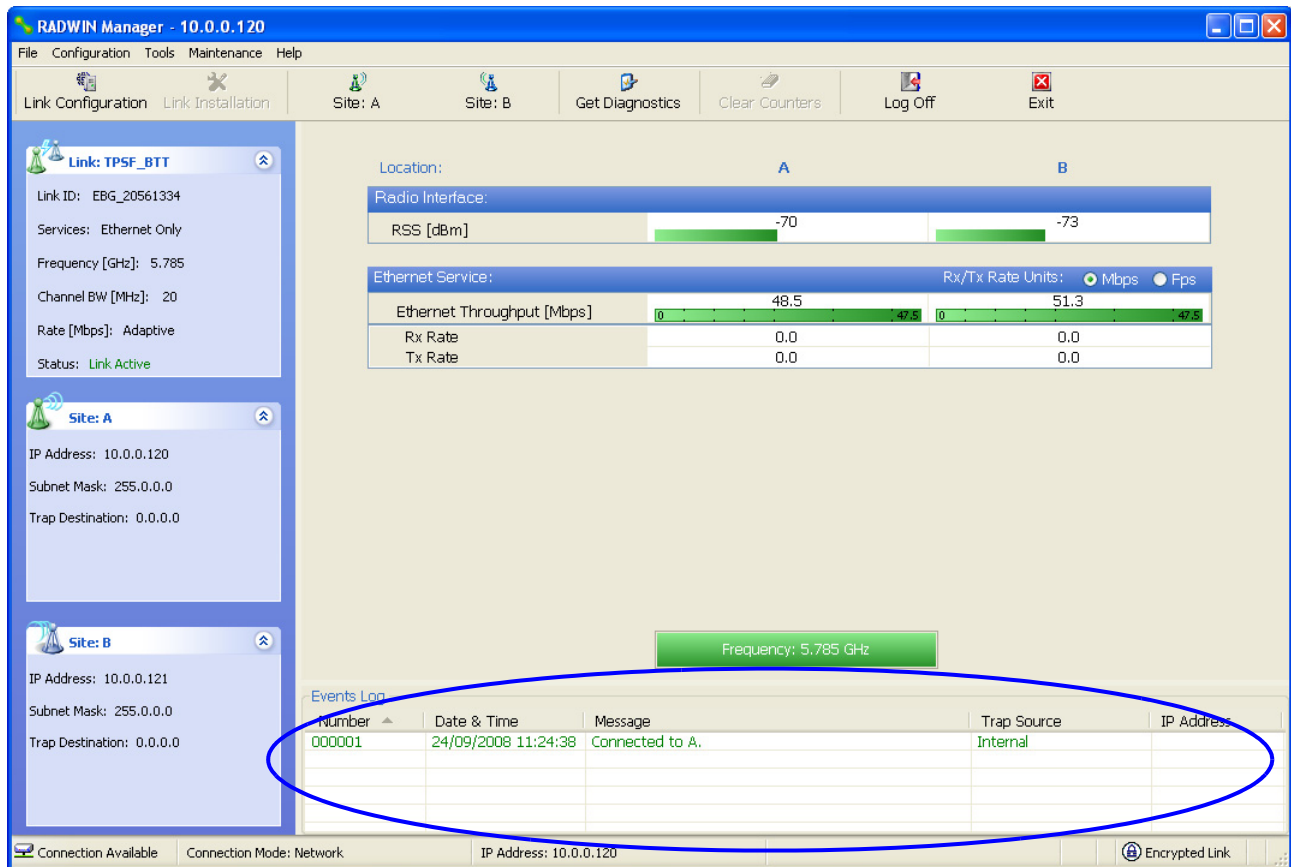

Figure 7-6: Events Log Display

RADWIN Manager Traps

The RADWIN Manager application issues traps to indicate various events, displayed in the Wvents Log.

Table 7-5: RADWIN Manager Trap Messages

Trap Message	Severity	Remarks
Error loading trap catcher. Port 162 is already in use.	Warning	NMS will not catch any traps from target, some other application has grabbed this port
Device unreachable!	Error	Check connectivity to target
Connected to <site_name>	Information	
<site_name> Site will be reset.	Information	
Restore Factory Default Settings in process on Site <site_name>	Information	
Factory Settings: The process was not finished due to connection issues.	Warning	Factory setting failed due to connectivity problem to target
Reset: The process was not finished due to connection issues.	Warning	Factory setting failed due to connectivity problem to target - Target will not be reset
Cannot Write to Monitor file. There is not enough space on the disk.	Warning	Free some space on disk and retry
Windows Error: <error_ID>. Cannot Write to Monitor file.	Warning	Operating System error
TDM Counters were cleared for both sides	Information	
Identical IP addresses at <local_site_name> and <remote_site_name>	Warning	Set up a different IP to each site
The Product is not identified at the <local_site_name> site.	Warning	NMS is incompatible with the target release
The Product is not identified at the <remote_site_name> site.	Warning	
The Product is not identified at both sites.	Warning	
Product Not Identified!	Warning	
The Manager identified a newer ODU release at the <remote_site_name> site.	Warning	ODU release is newer than NMS release. Wizards are not available. NMS will be used just for monitoring. Upgrade the NMS. (You will get this message as a pop up)

Table 7-5: RADWIN Manager Trap Messages

Trap Message	Severity	Remarks
The Manager identified a newer ODU release at both sites.	Warning	
The Manager identified a newer ODU release at the <local_site_name> site.	Warning	
Newer Version identified at the <local_site_name> site.	Warning	ODU release is newer than NMS release. Wizards are not available. NMS will be used just for monitoring. Upgrade the NMS
Newer Version identified at the <remote_site_name> site.	Warning	
Newer Version Identified!	Warning	

Setting the Events Preferences

You can define a color for the traps to be displayed in the Event Log window, according to the severity of the event. The severity is predefined.

➤ To set the trap color:

1. From the **Tools** menu, choose **Preferences**.
The Preferences dialog box appears.
2. Click the **Events** Tab:

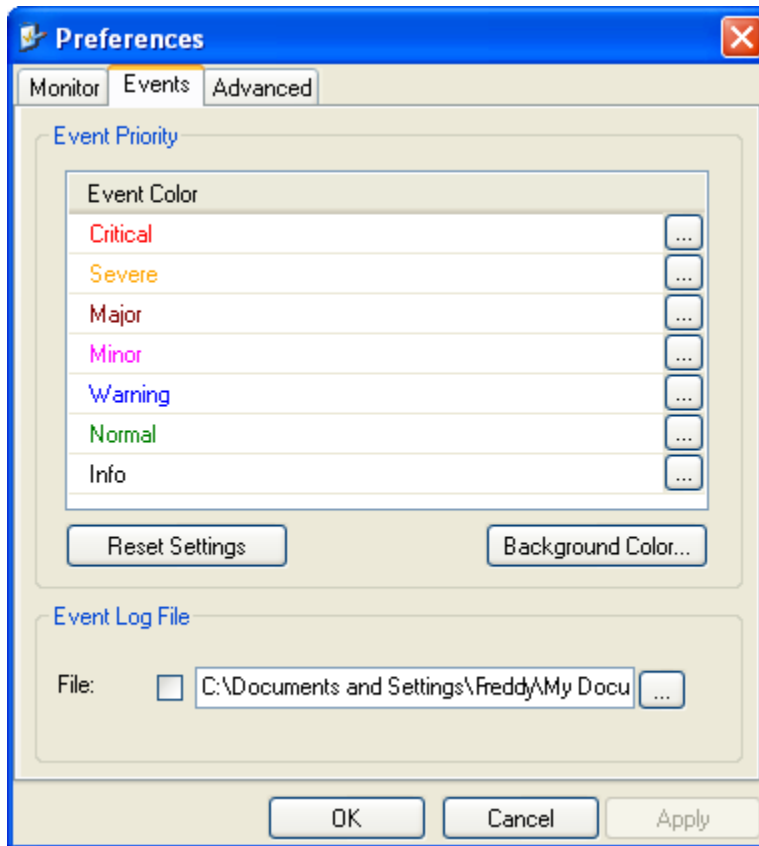



Figure 7-7: Preferences dialog box

3. Select the event type and click on the  button.
A color chart opens.
4. Select the desired color.
5. Repeat for all of the event types.

➤ **To set the trap background color:**

- Click **Background Color** to change the text background.

➤ **To reset the event colors:**

- Click **Reset Settings** to return to the default color settings.

Saving the Events Log

You can save recorded events in an Events Log text file. New alarms are automatically added to the text file, as they enter the Events Log.

➤ **To save the Events Log:**

1. From the Tools menu, choose **Preferences**.
The Preferences dialog box appears
2. Click the **Events** Tab.
3. Select the file to save.

4. Click the check box to open the file for saving.

Click the  button and in the Select File dialog box indicate in which folder and under what name the Events Log file is to be saved, and click OK.



To store the Events Log, first define the IP address, subnet mask, default gateway and trap address of the managing computer (see [Configuring the ODU Address](#) on [page 6-4](#) for details).

Reverting Alarm Messages

Alarm messages can be reverted to their default values by choosing the **Advanced** tab from the Preferences dialog:

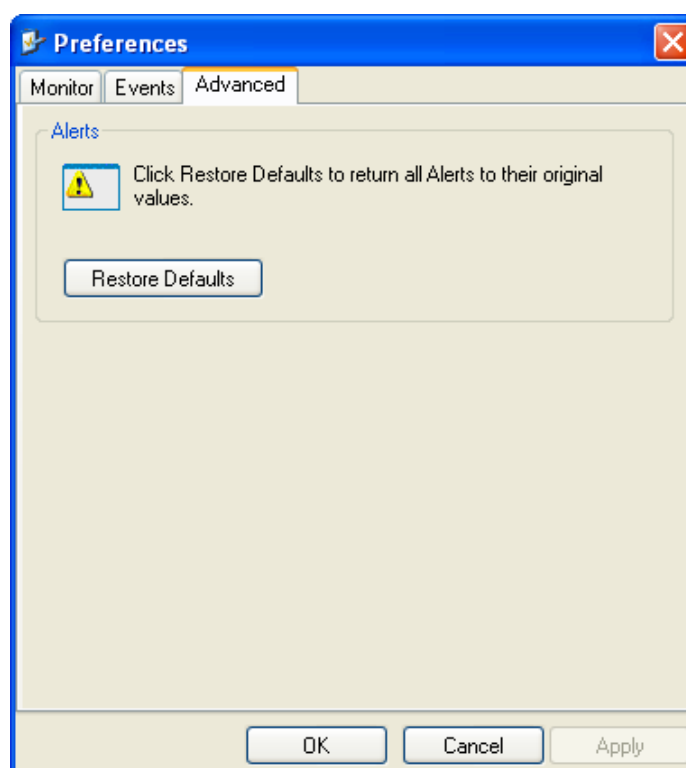

Just click the **Restore Defaults** button, followed by **OK**.

Active Alarms

Upon setting a trap destination, applicable events are reported as active alarms to the user. The active alarms are saved and can be viewed in the Active Alarms window.

➤ To view summary of saved alarms:

- From the Tools menu, choose Active Alarm Summary.
The Active Alarms Summary window opens:

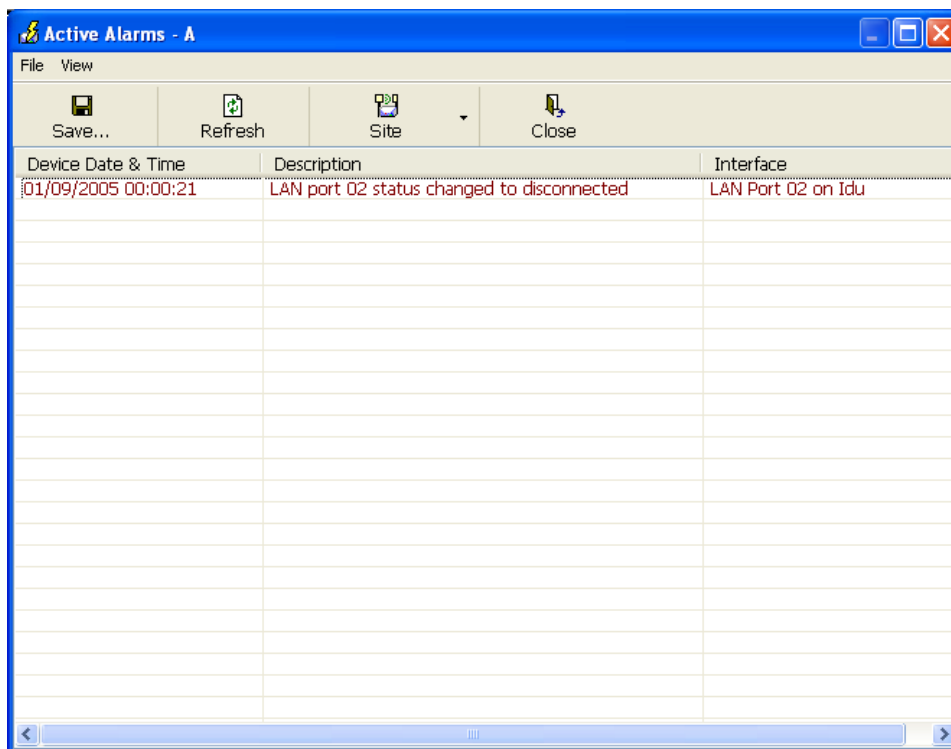

Figure 7-8: Active Alarms Summary

The following table provides an explanation of the command buttons

Table 7-6: Active Alarms command buttons

Command	Action
Save	Saves the alarms in CSV or text format for further analysis.
Refresh	Reads the alarms from the ODU.
Site	Selects site for the active alarms.
Close	Closes the active alarm window.

Remote Power Fail Indication

Remote power fail indication indicates to one side that the other side has had a power failure. The failed site sends a final trap indication about the power loss just before powering off.

A "Dying-Gasp" circuit identifies the power failure at a minimum interval of 20 milliseconds before the ODU or IDU powers off. During that interval a message notifying the power failure is sent to Site B. Alarm output number 4 indicates power failure at Site B.

Troubleshooting

Use the following table to troubleshoot LED fault indications:

Table 7-7: LED fault indicators

LED	Status	Remedy
PWR	Off	Check that AC adapter is connected to the IDU-E and the AC power outlet.
IDU	Orange	Check that the IDU/ODU cable is properly wired and connected.
ODU	Red	Check that the IDU/ODU cable is properly wired and connected.
AIR I/F	Orange	Complete the installation procedure from the management software.
	Red	Check the ODU Antenna alignment. Check that the radio configuration of both site A and site B units are the same (channel and Link ID).
SVC	Off	

Use the following table to troubleshoot faults in the system:.

Table 7-8: Troubleshooting

Symptom	Remedy
No power	Ensure that power is connected to the IDU.
	Ensure that the ODU cable is properly wired and connected.
No signal	Complete the installation procedure from the RADWIN Manager
	Check the ODU alignment. Check that the radio configuration of both site A and site B units are the same (channel and Link ID).
Weak signal received	Check the ODU alignment, reconfigure the link.
	Check the alignment tone sounds the Best Signal sequence.

Replacing an ODU

Prior to any action ensure that both ODUs have the same software version. You can see this on the inventory panels for each site.

For Site A, click **Site A | Inventory** and note the ODU software version. Repeat this for Site B using **Site B | Inventory**.

If either ODU has an old software version, perform a software upgrade. It is important to configure the new ODU exactly the same as the old ODU to avoid configuration mismatches, which will disrupt the link.

An ODU may be reconfigured in several ways.

- **Use the backup Configuration**

If a backup of the configuration is available, restore that configuration using **Site A | Restore**.

- **Manual Configuration**

The new ODU can be configured manually according to the link configuration. Remember to use the same settings for Link ID, channels, link password, IP addresses, and names.

Restoring Factory Setup

➤ **To restore factory setup:**

1. Set the remaining ODUs back to the factory setup by using the **Site A | Advanced** option.
2. Activate the second ODU and carry out a new Installation.

Online Help

Online help can be accessed from the Help menu on the main screen of the RADWIN 1000/2000 Manager.

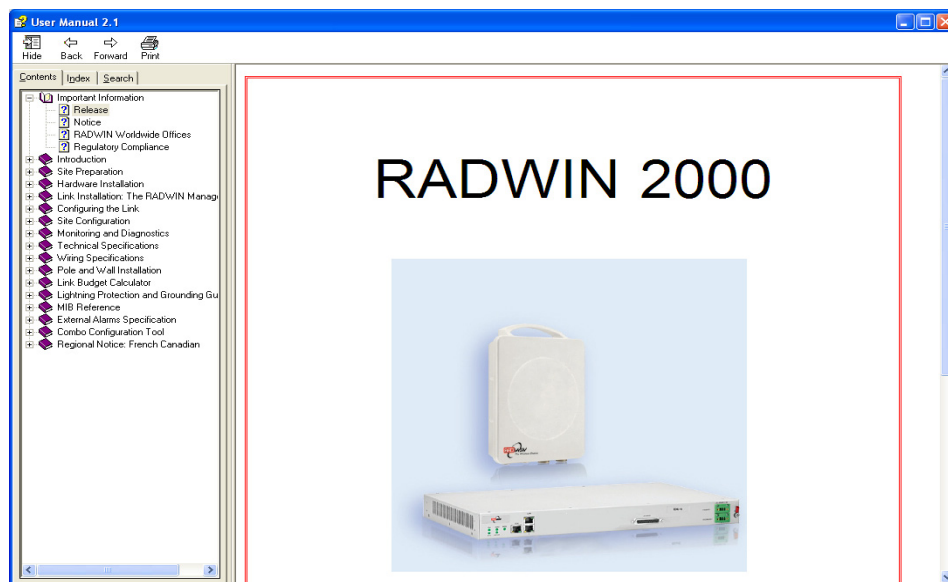

Figure 7-9: Online Help for RADWIN 1000/2000

Customer Support

Customer support for this product can be obtained from the local VAR, Integrator or distributor from whom it was purchased.

For further information, please contact the RADWIN 1000/2000 distributor nearest to you or one of RADWIN's offices worldwide (see [RADWIN Worldwide Offices](#) at the beginning of this manual).