

# E46034 Flush Mounting Kit for Ray48 & Ray54/E

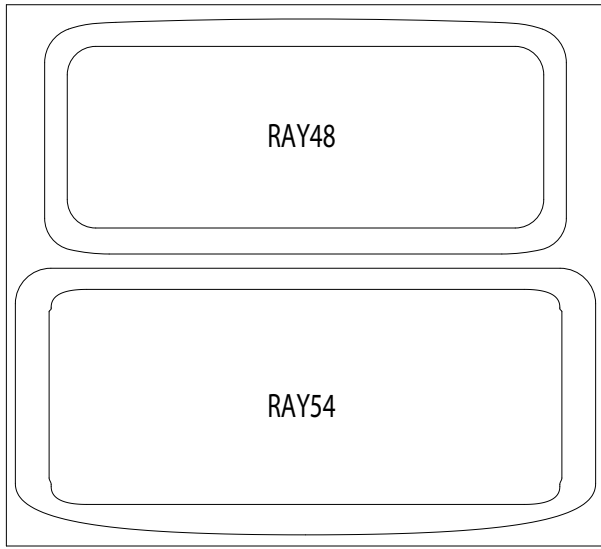

Pre-punched gaskets sheet

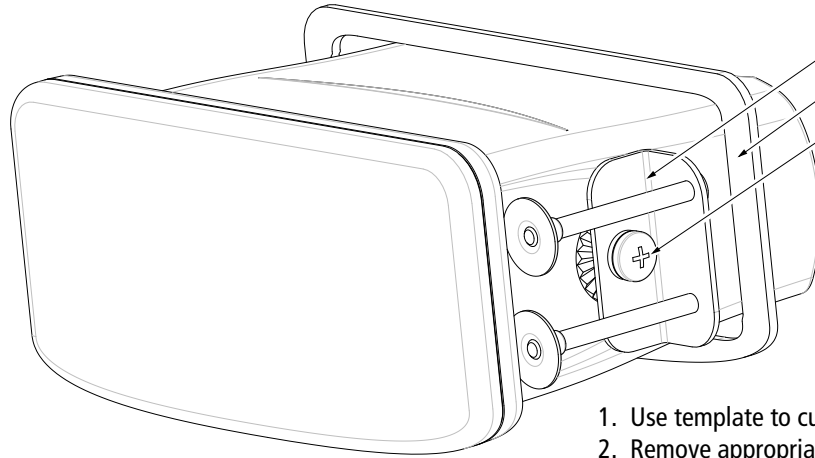

## 5583-002 Flush Mount Assembly

- Bracket Subassembly, qty 2
- Gasket, 1 ea, Ray48 & Ray54/E
- Screw, M6, qty 2, and Lock Washer, M6, qty 2

1. Use template to cut out required opening in console.
2. Remove appropriate Gasket from pre-punched sheet and place on radio, behind front fascia.
3. Insert unit into cutout in console.
4. Attach both Bracket Subassemblies to radio using M6 Screws and Lock Washers.
5. Tighten Bracket Subassembly mounting screws until unit snugly attached to console.

