

INSTALLATION AND OPERATING INSTRUCTIONS

MVB
Modulating Vertical Boiler



Models 504-2004
Types H, WH, P & WHP



WARNING: Improper installation, adjustment, alteration, service or maintenance can cause property damage, personal injury, exposure to hazardous materials* or loss of life. Review the information in this manual carefully. *This unit contains materials that have been identified as carcinogenic, or possibly carcinogenic, to humans.

FOR YOUR SAFETY: Do not store or use gasoline or other flammable vapors and liquids or other combustible materials in the vicinity of this or any other appliance. To do so may result in an explosion or fire.

WHAT TO DO IF YOU SMELL GAS:

- Do not try to light any appliance.
- Do not touch any electrical switch; do not use any phone in your building.
- Immediately call your gas supplier from a neighbor's phone. Follow the gas supplier's instructions.
- If you cannot reach your gas supplier, call the fire department.

Installation and service must be performed by a qualified installer, service agency or the gas supplier.

This manual should be maintained in legible condition and kept adjacent to the heater or in a safe place for future reference.



CONTENTS

WARNINGS	4	Important Instructions for the	
BEFORE INSTALLATION	5	Commonwealth of Massachusetts	53
Product Receipt	5	WARRANTY	54
Model Identification	5	START-UP CHECKLIST	56
Ratings and Certifications	5		
Installations at Elevation	5		
Component Locations	6		
General Information	6		
GENERAL SAFETY	7		
Time/Temperature Relationships in			
Scalds	7		
INSTALLATION	8		
Installation Codes	8		
Equipment Base	8		
Clearances	8		
Combustion and Ventilation Air	9		
Conventional Combustion Air Supply	11		
Water Piping	12		
Hydronic Heating	14		
Gas Supply	19		
Electrical Power Connections	20		
Field Wiring Connection	22		
Venting	22		
Venting Installation Tips	24		
Venting Configurations	24		
Outdoor Installation	29		
Controls	30		
Heater Sequence of Operation	36		
WIRING DIAGRAMS	41		
START-UP	43		
Pre Start-up	43		
Start-Up	44		
OPERATION	47		
Lighting Instructions	47		
To Turn Off Gas To Appliance	48		
TROUBLESHOOTING	49		
UDB Fault History	50		
MAINTENANCE	50		
Suggested Minimum			
Maintenance Schedule	50		
Preventative Maintenance Schedule	51		
APPENDIX	52		
Inside Air Contamination	52		

WARNINGS

Pay Attention to These Terms

DANGER:	Indicates the presence of immediate hazards which will cause severe personal injury, death or substantial property damage if ignored.
WARNING:	Indicates the presence of hazards or unsafe practices which could cause severe personal injury, death or substantial property damage if ignored.
CAUTION:	Indicates the presence of hazards or unsafe practices which could cause minor personal injury or product or property damage if ignored.
NOTE:	Indicates special instructions on installation, operation, or maintenance which are important but not related to personal injury hazards.

DANGER: Make sure the gas on which the heater will operate is the same type as that specified on the heater rating plate.

WARNING: Should overheating occur or the gas supply valve fail to shut, do not turn off or disconnect the electrical supply to the heater. Instead, shut off the gas supply at a location external to the heater.

WARNING: Do not use this heater if any part has been under water. Immediately call a qualified service technician to inspect the heater and to replace any part of the control system and any gas control which has been under water.

WARNING: To minimize the possibility of improper operation, serious personal injury, fire, or damage to the heater:

- Always keep the area around the heater free of combustible materials, gasoline, and other flammable liquids and vapors.
- Heater should never be covered or have any blockage to the flow of fresh air to the heater.

WARNING: Risk of electrical shock. More than one disconnect switch may be required to de-energize the equipment before servicing.

WARNING - CALIFORNIA PROPOSITION 65: This product contains chemicals known to the State of California to cause cancer, birth defects or other reproductive harm.

CAUTION: Operation of this heater in low temperature systems requires special piping. Harmful internal condensation will occur if the inlet water temperature does not exceed 120°F. Warranty claims will be denied when condensation occurs.

CAUTION: If this heater is to be installed above radiation level, it must be provided with a low water cut-off device at the time of heater installation.

CAUTION: This heater requires forced water circulation when the burner is operating. See minimum and maximum flow rates. Severe damage will occur if the heater is operated without proper water flow circulation.

CAUTION: If this heater is to be installed in a negative or positive pressure equipment room, there are special installation requirements. Consult factory for details.

BEFORE INSTALLATION

Raypak strongly recommends that this manual be reviewed thoroughly before installing your MVB heater. Please review the General Safety information before installing the heater. Factory warranty does not apply to heaters that have been improperly installed or operated. (Refer to the warranty at the back of this manual.) Installation and service must be performed by a qualified installer, service agency or gas supplier. If, after reviewing this manual, you still have questions which this manual does not answer, please contact the manufacturer or your local Raypak representative.

Thank you for purchasing a Raypak product. We hope you will be satisfied with the high quality and durability of our equipment.

Product Receipt

On receipt of your heater it is suggested that you visually check for external damage to the shipping crate. If the crate is damaged, make a note to that effect on the Bill of Lading when signing for the shipment. Remove the heater from the shipping packaging. Report any damage to the carrier immediately.

On occasion, items are shipped loose. Be sure that you receive the correct number of packages as indicated on the Bill of Lading.

Claims for shortages and damages must be filed with the carrier by consignee. Permission to return goods must be received from the factory prior to shipping. Goods returned to the factory without an authorized Returned Goods Receipt number will not be accepted. All returned goods are subject to a restocking charge.

When ordering parts, you must specify the model and serial number of the heater. When ordering under warranty conditions, you must also specify the date of installation.

Purchased parts are subject to replacement only under the manufacturer's warranty. Debits for defective replacement parts will not be accepted and will be replaced in kind only per Raypak's standard warranties.

Model Identification

The model identification number and heater serial number are found on the heater rating plate located on

the upper rear jacket panel of the heater. The model number will have the form H7-2004 or similar depending on the heater size and configuration. The letter(s) in the first group of characters identifies the application (H = Hydronic Heating, P = Pool Heating, WH = Domestic Hot Water (DHW), WHP = Water Heater for Pool Heating). The number which follows identifies the firing mode (7 = electronic modulation, 1 = On/Off). The second group of characters identifies the size of the heater (three or four numbers representing the approximate MBTUH input), and, where applicable, a letter, indicating the manufacturing series.

Ratings and Certifications

Standards:

- ANSI 21.56 · CSA 4.7 - latest edition, Gas-Fired Pool Heaters
- ANSI Z21.13 · CSA 4.9 - latest edition, Gas-Fired Hot Water Boilers
- CAN 3.1 - latest edition, Industrial and Commercial Gas-Fired Package Boilers
- ANSI Z21.10.3 · CSA 4.3 - latest edition, Gas Water Heaters
- SCAQMD Rule 1146.2

All Raypak heaters are National Board Approved, and design-certified and tested by the Canadian Standards Association (CSA) for the U.S. and Canada. Each heater is constructed in accordance with Section IV of the American Society of Mechanical Engineers (ASME) Heater Pressure Vessel Code and bears the ASME stamp. The heater also complies with the latest edition of ASHRAE 90.1 Standard.

WARNING: Altering any Raypak pressure vessel by installing replacement heat exchangers, tube bundle headers, or any ASME parts not manufactured and/or approved by Raypak will instantly void the ASME and CSA ratings of the vessel and any Raypak warranty on the vessel. Altering the ASME or CSA ratings of the vessel also violates national, state, and local approval codes.

Installations at Elevation

Rated inputs are suitable for up to 4,500 ft elevation without de-rating. Consult the factory for installations at altitudes over 4,500 ft above sea level. No hardware changes are required to the heaters for installations up to 10,000 ft (adjustments may be required).

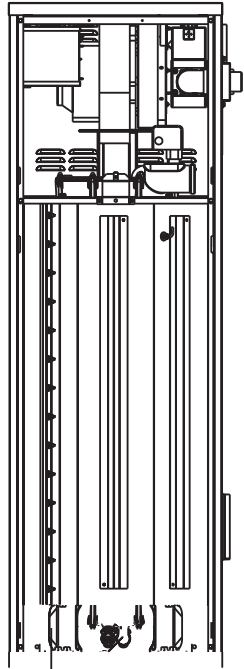

General Information

Model No.	MBTUH Input*	(MBTUH)	(MBTUH)	Flue	Intake
				P Flue	Intake
	350	2		8	6
	770				6
1500	1050				8
1999	1400				8

*H7 units only.

Table A: Basic Data

GENERAL SAFETY

To meet commercial hot water use needs, the high limit safety control on this water heater is adjustable up to 210°F. However, water temperatures over 125°F can cause instant severe burns or death from scalds. When supplying general purpose hot water, the recommended initial setting for the temperature control is 125°F.

This section applies to Hot Water Supply Boilers and Hot Water Heaters ONLY. For sanitary rinse applications where outlet temperatures of 180°F to 195°F are required, a boiler is recommended since the 210°F limit on water heaters will NOT allow the heater to maintain these desired sanitary rinse temperatures.

Safety and energy conservation are factors to be considered when setting the water temperature on the thermostat. The most energy-efficient operation will result when the temperature setting is the lowest that satisfies the needs of the application.

Water temperature over 125°F can cause instant severe burns or death from scalds. Children, disabled and elderly are at highest risk of being scalded.

- Feel water before bathing or showering.
- Temperature limiting valves are available.

NOTE: When this water heater is supplying general purpose hot water for use by individuals, a thermostatically controlled mixing valve for reducing point of use water temperature is recommended to reduce the risk of scald injury. Contact a licensed plumber or the local plumbing authority for further information.

Maximum water temperatures occur just after the heater's burner has shut off. To determine the water temperature being delivered, turn on a hot water faucet and place a thermometer in the hot water stream and read the thermometer.



Water temperatures over 125°F can cause instant severe burns or death from scalds.

Children, disabled and elderly are at highest risk of being scalded.

See instruction manual for setting temperature.

Feel water before bathing or showering.

Temperature limiting valves are available, see manual for details.

The temperature of the water in the heater can be regulated by using the Raypak Modulating Temperature Control. To comply with safety regulations, the control is set at 120°F when shipped from the factory (Mode 3 default setting for Tank Target).

To adjust the water temperature, follow the instruction for the operation of the control starting on page 30 of this manual. The control is shown below for identification purposes only. (See Fig. 4.)

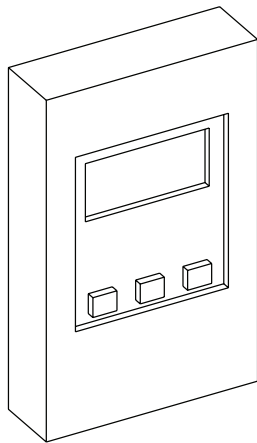

Fig. 4: Modulating Temperature Control

CAUTION: Hotter water increases the risk of scalding! There is a hot water scald potential if the thermostat is set too high.

INSTALLATION

Installation Codes

Installations must follow these codes:

- Local, state, provincial, and national codes, laws, regulations and ordinances
- National Fuel Gas Code, ANSI Z223.1/NFPA 54 – latest edition (NFGC)
- National Electrical Code, ANSI/NFPA 70 - latest edition (NEC)
- Standard for Controls and Safety Devices for Automatically Fired Boilers, ANSI/ASME CSD-1, (CSD-1) when required
- For Canada only: CAN/CSA B149 Natural Gas and Propane Installation Code and CSA C22.1 C.E.C. Part 1 (C22.1)

Equipment Base

The heater should be mounted on a level, structurally sound surface. The heater is approved for installation on a combustible surface but must NEVER be installed on carpeting. Gas-fueled equipment installed in enclosed parking garages must be located at least 18 in. above the floor.

CAUTION: The heater should be located in an area where water leakage will not result in damage to the area adjacent to the appliances or to the structure. When such locations cannot be avoided, it is recommended that a suitable catch pan, adequately drained, be installed under the appliance. The pan must not restrict air flow.

In addition, the heater shall be installed such that the gas ignition system components are protected from water (dripping, spraying, rain, etc.) during appliance operation or service (circulator replacement, control replacement, etc.).

If the heater needs to be secured to the ground, use the brackets that were used to bolt the heater to the shipping pallet.

Clearances

Indoor Installations

Heater Side	Minimum Clearance from Combustible Surfaces	Recommended Service Clearance
Floor*	0"	0"
Rear	12"	24"
Right Side	1"	1"
Left Side	1"	1"
Top	0"	10"
Front	Open	24"
Vent	1"	1"

*DO NOT install on carpeting.

Table C: Clearances – Indoor Installations

When installed according to the listed minimum clearances from combustible construction, these heaters can still be serviced without removing permanent structural construction around the heater. However, for ease of servicing, we recommend a clearance of at least 24 in. in front, at least 24 in. on the rear and 10 in. above the top of the heater. This will allow the

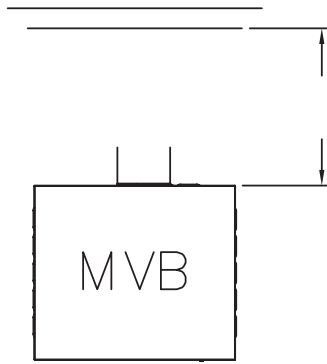

Three sides must be open in the area under the overhang. Roof water drainage must be diverted away from heaters installed under overhangs.

The combustion air intake terminal **MUST** be used for outdoor installations. The hood is shipped loose and installed on the rear of the heater at the jobsite.

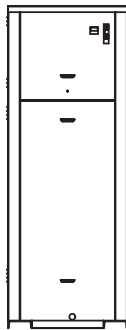
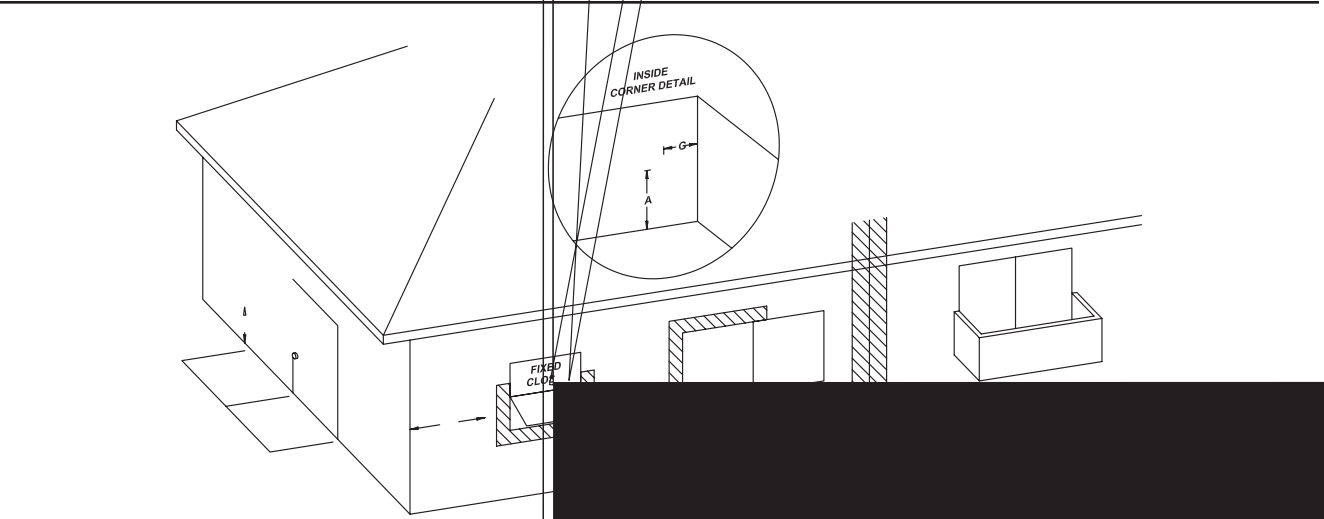

Table D: Clearances – Outdoor Installations

Fig. 5: Minimum Clearances from Combustible Surfaces – Indoor and Outdoor Installations



Optional Construction Air Filter

An optional construction air filter is available for use. The filter should be removed after construction is finished to allow for unrestricted air flow to the heater.

Direct Vent

If outside air is drawn through the intake pipe directly to the unit for combustion:

1. Install combustion air direct vent in accordance with Fig. 24 (horizontal) or Fig. 25 (vertical) of this manual (pages 28 and 29, respectively).
2. Provide adequate ventilation of the space occupied by the heater(s) by an opening(s) for ventilation air at the highest practical point communicating with the outdoors. The total cross-sectional area shall be at least 1 in.² of free area per 20,000 BTUH (111 mm² per kW) of total input rating of all equipment in the room when the opening is communicating directly with the outdoors or through vertical duct(s). The total cross-sectional area shall be at least 1 in.² of free area per 10,000 BTUH (222 mm² per kW) of total input rating of all equipment in the room when the opening is communicating with the outdoors through horizontal duct(s).
3. In cold climates, and to mitigate potential freeze-up, Raypak highly recommends the installation of a motorized sealed damper to prevent the circulation of cold air through the heater during the non-operating hours.

TruSeal™ Combustion Air

In addition to the 3 previous steps, combustion air may be ducted directly to the heater by using PVC, CPVC or sealed single-wall galvanized ducting. The duct will attach directly to the air collar located on the rear of the heater, using three or four sheet metal screws (not supplied) equally positioned around the circumference of the duct. The screen assembly should be removed before attaching any air duct to the heater. The screws and duct connection point must be sealed with RTV (not supplied). TruSeal is generally used when damaging contaminants are present in the mechanical room.

All ducting must be self-supported.

CAUTION: Use TruSeal combustion air if damaging airborne contaminants are or may be present in the heater area. See the Appendix of this manual regarding air contamination.

Conventional Combustion Air Supply

U.S. Installations

All Air from Inside the Building

The confined space shall be provided with **TWO** permanent openings communicating directly with an additional room(s) of sufficient volume so that the combined volume of all spaces meets the criteria for a room large in comparison (NFGC). The total input of all gas utilization equipment installed in the combined space shall be considered in making this determination. **Each opening** shall have a minimum free area of 1 in.² per 1,000 BTUH (2,225 mm² per kW) of the total input rating of all gas utilization equipment in the confined space, but not less than 100 in.² (645 cm²). One opening shall commence within 12 in. (305 mm) of the top, and one opening shall commence within 12 in. (305 mm) of the bottom of the enclosure. The minimum dimension of air openings shall be not less than 3 in. (76 mm) in any direction.

All Air from Outdoors

The confined space shall communicate with the outdoors in accordance with one of the methods below. The minimum dimension of air openings shall not be less than 3 in. (76 mm) in any direction. Where ducts are used, they shall be of the same cross-sectional area as the net free area of the openings to which they connect.

1. **Two permanent openings**, one commencing within 12 in. (305 mm) of the top, and one commencing within 12 in. (305 mm) of the bottom of the enclosure, shall be provided. The openings shall communicate directly, or by ducts, with the outdoors or spaces (crawl or attic) that freely communicate with the outdoors.
 - a. Where directly communicating with the outdoors or where communicating to the outdoors through vertical ducts, **each opening** shall have a minimum free area of 1 in.² per 4,000 BTUH (550 mm² per kW) of total input rating of all equipment in the enclosure.

- b. Where communicating with the outdoors through horizontal ducts, each opening shall have a minimum free area of 1 in.² per 2,000 BTUH (1,100 mm² per kW) of total input rating of all equipment in the enclosure.
2. **One permanent opening**, commencing within 12 in. (305 mm) of the top of the enclosure, shall be permitted where the equipment has clearances of at least 1 in. (25 mm) from the sides and back and 6 in. (152 mm) from the front of the appliance. The opening shall directly communicate with the outdoors or shall communicate through a vertical or horizontal duct to the outdoors or spaces that freely communicate with the outdoors, and shall have a minimum free area of:
- a. 1 in.² per 3,000 BTUH (740 mm² per kW) of the total input rating of all equipment located in the enclosure, and
- b. Not less than the sum of the areas of all vent connectors in the confined space.

WARNING: Do not use the “one permanent opening” method if the equipment room is under negative pressure conditions.

Canadian Installations

CAUTION: All combustion air must be drawn from outside of the building; the mechanical equipment room must communicate directly with the outdoors.

1. Ventilation of the space occupied by the heater shall be provided by an opening(s) for ventilation air at the highest practical point communicating with the outdoors. The total cross-sectional area of such an opening(s) shall be at least 10% of the area required in 2. and 3. (below), but in no case shall the cross-sectional area be less than 10 in.² (65 cm²).
2. For heaters using a barometric damper in the vent system there shall be a permanent air supply opening(s) having a cross section area of not less than 1 in.² per 7,000 BTUH (320 mm² per kW) up to and including 1 million BTUH, plus 1 in.² per 14,000 BTUH (160 mm² per kW) in excess of 1 million BTUH. This opening(s) shall be either located at or ducted to a point not more than 18 in. (450 mm) nor less than 6 in. (152 mm) above the floor level. The duct can also “goose neck” through
- the roof. The duct is preferred to be straight down and terminated 18 in. (450 mm) from the floor, but not near piping. This air supply opening requirement shall be in addition to the air opening for ventilation air required in 1. (above).

WARNING: Care must be taken to ensure that the equipment room is not under negative pressure conditions.

3. For heaters not using a barometric damper in the vent system, and when air supply is provided by natural air flow from outdoors for a power burner and there is no draft regulator, draft hood or similar flue gas dilution device installed in the same space, in addition to the opening for ventilation air required in 1., there shall be a permanent air supply opening(s) having a total cross-sectional area of not less than 1 in.² for each 30,000 BTUH (74 mm² per kW) of total rated input of the burner(s), and the location of the opening(s) shall not interfere with the intended purpose of the opening(s) for ventilation air referred to in 1. This opening(s) can be ducted to a point not more than 18 in. (450 mm) nor less than 6 in. (152 mm) above the floor level. The duct can also “goose neck” through the roof. The duct is preferred to be straight down 18 in. (450 mm) from the floor, but not near piping.
4. Refer to B149 Installation Code for additional information.

Water Piping

General

The heater should be located so that any water leaks will not cause damage to the adjacent area or structures.

CAUTION: This heater requires forced water circulation when the burner is operating. See Table F and Table G for minimum and maximum flow rates and water pump selection. The pump must be interlocked with the heater to prevent heater operation without water circulation.

NOTE: : Minimum pipe size for in/out connections is 2 in. NPT for 504 and 754 models and 2-½ in NPT for 1104 – 2004 models. Verify proper flow rates and ΔT as instructed in this manual.

Relief Valve Piping

WARNING: Pressure relief valve discharge piping must be piped near the floor and close to a drain to eliminate the potential of severe burns. Do not pipe to any area where freezing could occur. Refer to local codes.

Hydrostatic Test

Unlike many types of heaters, this heater does not require hydrostatic testing prior to being placed in operation. The heat exchanger has already been factory-tested and is rated for 160 psi operating pressure. However, Raypak does recommend hydrostatic testing of the piping connections to the heater and the rest of the system prior to operation. This is particularly true for hydronic systems using expensive glycol-based anti-freeze. Raypak recommends conducting the hydrostatic test before connecting gas piping or electrical supply.

Leaks must be repaired at once to prevent damage to the heater. NEVER use petroleum-based stop-leak compounds.

To perform hydrostatic test:

1. Connect fill water supply. With bleed valve open, fill heater with water. When water flows from bleed valve, shut off water. Close bleed valve. Carefully fill the rest of the system, making sure to eliminate any entrapped air by using high-point vents. Close feed valve. Test at standard operating pressure for at least 24 hours.
2. Make sure constant gauge pressure has been maintained throughout test.
3. Check for leaks. Repair if found.

Cold Water Operation

CAUTION: Damage due to internal condensation may occur if the heater inlet water temperature does not exceed 120°F (41°C) within 7 minutes of start-up.

This heater is equipped with a proprietary condensate evaporation system which will evaporate any condensate that may begin to accumulate inside the primary heat exchanger with water temperatures as low as 120°F (49°C).

Heaters operated with an inlet temperature of less than 120°F (49°C) MUST have a manual bypass (see Fig. 14) or an approved low-temperature operation system to prevent problems with condensation. This piping is like a primary/secondary boiler installation with a bypass acting as the secondary boiler piping. Raypak strongly recommends that thermometer(s) be placed into the heater piping next to the in/out header to facilitate temperature adjustment. Inlet water temperatures below 120°F (49°C) can excessively cool the products of combustion, resulting in collection of condensate in the heat exchanger area beyond the capacity of the condensate evaporation system.

NOTE: Vent piping MUST contain a condensate drain which is installed according to the vent manufacturer's instructions and plumbed to an appropriate condensate management system (field supplied).

Failure to reach or exceed 120°F (49°C) within 7 minutes may damage or cause failure of the heat exchanger, combustion chamber, or other parts within the combustion chamber. It can cause operational problems, bad combustion, sooting, flue gas leakage and reduced service life of the vent system. A bypass allows part of the heater discharge water to be mixed with the cooler water returning to the heater inlet to increase the heater inlet temperature above 120°F (49°C). This precautionary measure should prevent the products of combustion from condensing beyond the ability of the condensate management system employed in this heater in most installations. **Warranty claims will be denied for damage or failures caused by condensation.**

Cold water operation issues are applicable to both cold water start and cold water run applications. Cold water operation for 7 minutes or less on initial daily start-up is acceptable. Where cold water starts will last longer than 7 minutes or where cold water operation is continuous, provisions must be made to mix higher temperature outlet water with the colder inlet water and thereby raise the inlet temperature to at least 120°F (49°C) within the 7-minute time limit.

Cold Water Starts

Cold water starts, wherein the inlet water temperature remains below 120°F (49°C) for more than 7 minutes, **must have cold water start protection.** Known protection methods consist of mixing heated outlet water with the inlet water with a bypass to raise the inlet to 120°F (49°C) or higher. Once the system is heated up and has return water temperatures of 120°F (49°C) or higher, the mixing of outlet water with inlet water is no

longer needed and the bypass can be shut off. If the bypass is not shut off as the system heats up, the outlet temperature may continue to climb and trip the high limit, thereby shutting down the heater. Thus an automatic valve system, such as a three-way proportional valve or a modulating two-way valve to control the bypass, should be utilized.

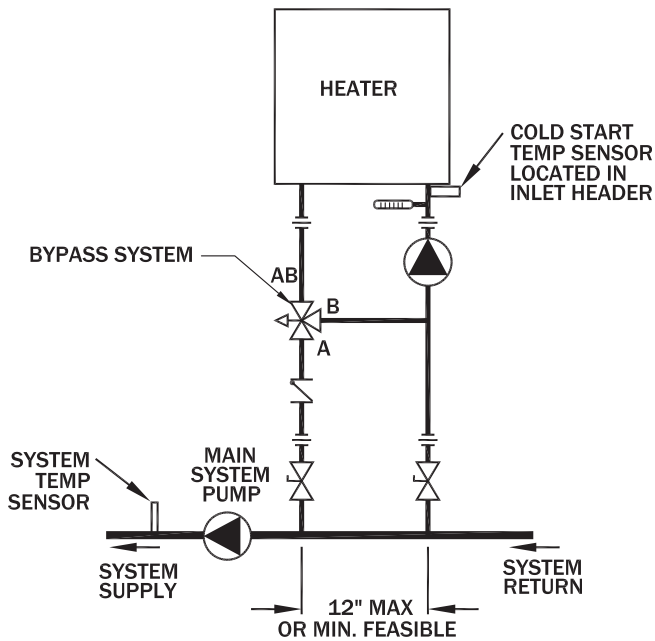

Fig. 7: Cold Water Start

Cold Water Run

Cold water run differs from cold water start in that the system water entering the heater remains below 120°F (49°C) continuously. Typically, this is the case in swimming pool heating. If the system water is kept in a narrow temperature range of no more than 10°F (5°C), a permanent manual bypass can be employed and manually adjusted to achieve an inlet temperature of 120°F (49°C) or higher as adjusted at the minimum temperature in this narrow temperature range (i.e. Range 75°F – 85°F – adjust bypass with temperature at 75°F (24°C)) so that when temperature is 85°F (29°C), minimum inlet temperature would be 130°F (54°C). An injector pump arrangement may also be utilized to keep the heater loop at or above 120°F (49°C). An injector pump approach has the added value of being able to adjust to changes in the system water coming back to the heater take-off.

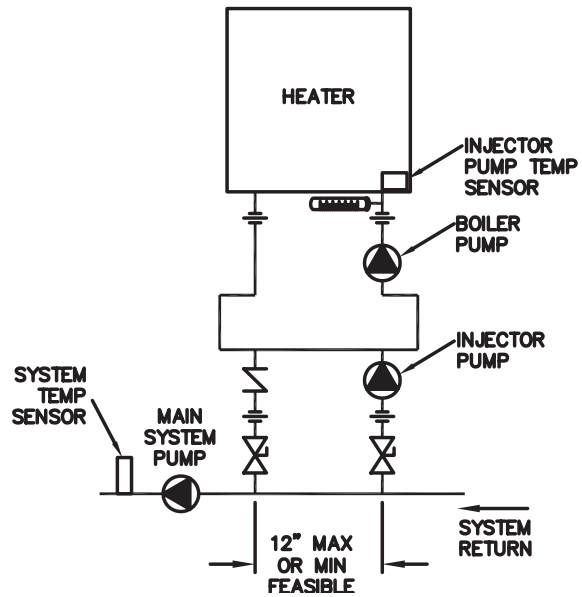

Fig. 8: Cold Water Run

Temperature & Pressure Gauge

The temperature and pressure gauge is shipped loose for field installation in the outlet piping.

Hydronic Heating

Pump Selection

In order to ensure proper performance of your heater system, you must install a correctly-sized pump. Raypak recommends designing for a ΔT within the range of 10°F to 40°F (5°C to 20°C). See Table F for acceptable flow rates for each model (ΔT is the temperature difference between the inlet and outlet water when the heater is firing at full rate).

Feedwater Regulator

Raypak recommends that a feedwater regulator be installed and set at 12 psi minimum pressure at the highest point of the system. Install a check valve or back flow device upstream of the regulator, with a manual shut-off valve as required by local codes.

Piping

All high points should be vented. A heater installed above radiation level must be provided with a low water cut-off device (sales order option F-10). The heater, when used in connection with a refrigeration system, must be installed so that the chilled medium is piped in parallel with the heater with appropriate valves to prevent the chilled medium from entering the heater.

Note: Basis for minimum flow is ΔT . Basis for maximum flow is gpm.

Table F: Heater Rates of Flow and Pressure Drops

The piping system of a hot water heater connected to heating coils located in air handling units where they may be exposed to circulating refrigerated air, must be equipped with flow control valves or other automatic means to prevent gravity circulation of the heater water during the cooling cycle. It is highly recommended that the piping be insulated.



AIR SEPARATOR
WITH BLEED

Separation

Way V

Way V... regulate system water
... flow in the boiler should not
... are high-recovery, low-mass
... not subject to thermal shock. See
... instructions on page 18 for adjusting the
... bypass.

Domestic Hot Water

When designing the water piping system for domestic hot water applications, water hardness should be considered. Table G indicates the suggested flow rates for soft, medium and hard water. Water hardness is expressed in grains per gallon.

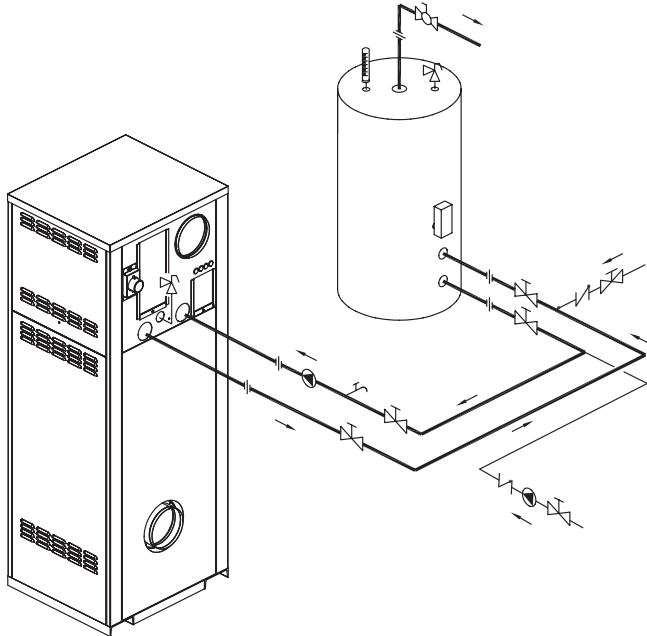

Fig. 12: Single Domestic Hot Water Heater and Storage Tank

NOTE: If local codes require a vacuum relief valve, acquire one locally and install per valve manufacturer's instructions.

Potable Water and Space Heating

CAUTION: When this heater is used for both potable water and space heating, observe the following to ensure proper operation.

1. All piping materials and components connected to the water heater for the space heating application shall be suitable for use with potable water.
2. Toxic chemicals, such as used for boiler treatment, shall not be introduced into the potable water used for space heating.
3. If the heater will be used to supply potable water, it shall not be connected to any heating system or components previously used with a non-potable water heating appliance.
4. When the system requires water for space heating at temperatures higher than 140°F (60°C), a means such as a mixing valve shall be installed to temper the water in order to reduce scald hazard potential.

Pool Heating

When a boiler or water heater is used in a pool heating application, ensure that all the following installation requirements are met.

The MVB must be equipped with a field-supplied external pump and bypass arrangement. This arrangement blends outlet water with the inlet water to

Model No.	MBTUH		Soft (0-4 grains per gallon)					Medium (5-15 grains per gallon)				Hard* (16-25 grains per gallon)					
	Input	Output	ΔT	gpm	ΔP	MTS	SHL	ΔT	gpm	ΔP	MTS	SHL	ΔT	gpm	ΔP	MTS	SHL
504	500	420	17	50	3.6	2	5.9	13	65	5.5	2	9.3	9	95	10.4	2	18.1
754	750	630	25	50	4.0	2	6.3	20	65	6.4	2	10.2	13	100	13.8	2	22.2
1104	1045	888	30	60	6.4	2-1/2	7.6	20	92	13.2	2-1/2	15.9	16	113	18.7	2-1/2	22.6
1504	1425	1211	30	82	12.7	2-1/2	14.9	22	113	22.3	2-1/2	26.3	22	113	22.3	2-1/2	26.3
2004	1900	1615	30	110	26.1	2-1/2	29.8	29	113	27.4	2-1/2	31.3	29	113	27.4	2-1/2	31.3

ΔT = Temperature rise, °F

ΔP = Pressure drop through heat exchanger, ft

SHL = System head loss, ft (based on heater and tank placed no more than 5 ft apart and equivalent length of 25 ft of tubing)

gpm = Gallons per minute, flow rate

MTS = Minimum tubing size

* Must use optional cupro-nickel tubes. If over 20 grains per gallon, a water softening system must also be used.

Table G: Domestic Water Heater Flow Rate Requirements

increase the inlet water temperature to a minimum of 105°F (40°C) for Pool Heater (P and WHP) versions and 120°F (49°C) for Hydronic Heating (H7) or Domestic Hot Water (WH1) versions, thereby reducing the likelihood of condensation forming on the heat exchanger. The pump also serves to circulate water through the heater from the main system piping.

CAUTION: Power to the heater should be interlocked with the main system pump to make sure the heater does not fire without the main system pump in operation. Improper flow control can damage the heater. Uncontrolled flow (too high) or restricted flow (too low) can seriously damage the heater. Follow these instructions to make sure your heater is properly installed.

To complete the installation of the pool heater, the pool thermostat needs to be installed in the main return water line, upstream of the heater. This will ensure that the heater will be energized at the right time.

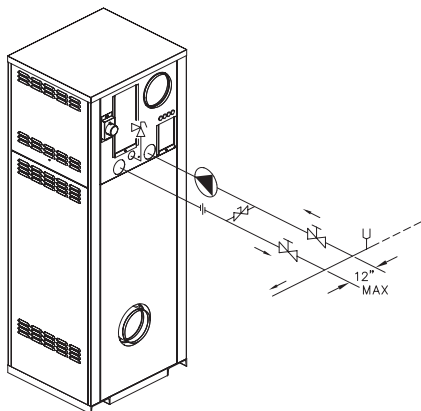

Fig. 13: Single Pool Heater Application

Adjustment of the manual bypass valve is critical to proper operation of the heater. The manual bypass valve should be adjusted to achieve a minimum inlet water temperature of 105°F (40°C) for Pool Heater (P and WHP) versions and 120°F (49°C) for Hydronic Heating (H7) or Domestic Hot Water (WH1) versions and a system supply water temperature below 140°F (60°C). When starting with a cold pool, make initial adjustments. Make final adjustments when pool water approaches desired temperature.

The use of a bypass is required for proper operation in a pool heating application. Use the following instructions to set the manual bypass:

1. Turn on pump.

2. Turn on heater and wait until heater goes to full fire.
3. With the heater operating at 100% firing rate, set Valve A (the bypass) to ½ open position, and Valve B to fully open position. See Fig. 14.
4. Adjust Valve A until the inlet water temperature is 105°F (40°C) or 120°F (49°C) depending upon heater type.

NOTE: Opening the valve will increase the temperature and closing the valve will decrease the temperature.

5. If this process does not raise the inlet water temperature to 105°F (40°C) for Pool Heater (P and WHP) versions and 120°F (49°C) for Hydronic Heating (H7) or Domestic Hot Water (WH1) versions and Valve A is fully open, then slowly throttle Valve B closed to increase the inlet water temperature to the required temperature.

Automatic Chlorinators and Chemical Feeders

CAUTION: Combustion air must not be contaminated by corrosive chemical fumes which can damage the heater and void the warranty.

All chemicals must be introduced and completely diluted into the pool or spa water before being circulated through the heater. Do not place chlorine tablets or bromine sticks in the skimmer. High chemical concentrations will result when the pump is not running (e.g. overnight). Chlorinators must feed downstream of the heater and have an anti-siphoning device to prevent chemical back-up into the heater when the pump is shut off.

NOTE: High chemical concentrates from feeders and chlorinators that are out of adjustment will cause very rapid corrosion of the heat exchanger in the heater. Such damage is not covered under the warranty.

Winterizing Your Heater

Heaters installed outdoors as pool heaters in freezing climate areas should be shut down for the winter. To shut down heater, turn off manual main gas valve and main gas shut-off. Close isolation valves. Drain the heater using the hose bibs located on the bottom of the heat exchanger.

NOTE: There are 2 separate drains on the MVB that must BOTH be drained to protect the heat exchanger. These are both accessible by removing the lower front door from the heater. Drain any piping of all water that may experience below-freezing temperatures.

Pool/Spa Water Chemistry

CAUTION: Corrosive water voids all warranties.

NOTE: Chemical imbalance can cause severe damage to your heater and associated equipment.

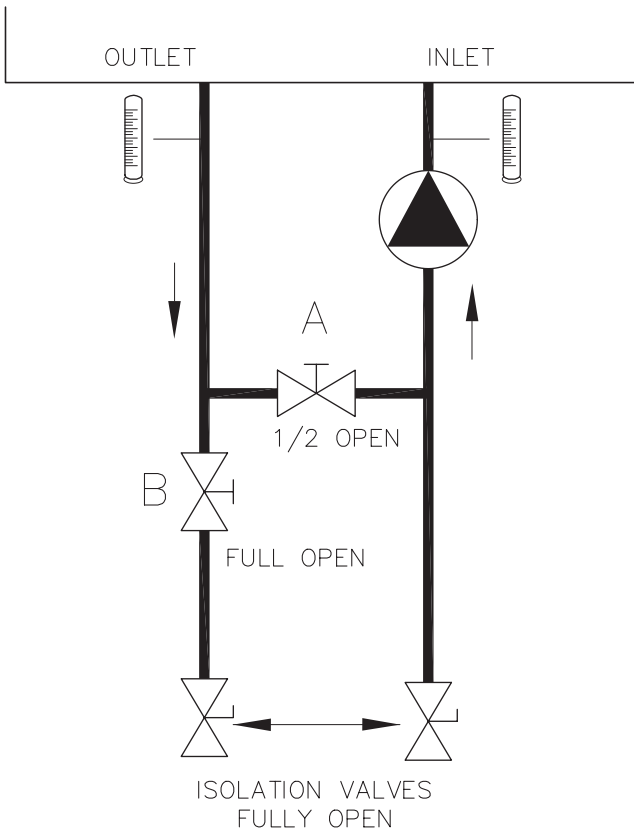

Fig. 14: "H" Bypass Setting

Chemical imbalance can cause severe damage to your heater and associated equipment. Maintain your water chemistry according to the chart below. If the mineral content and dissolved solids in the water become too high, scale forms inside the heat exchanger tubes, reducing heater efficiency and damaging the heater. If the pH drops below 7.2, this will cause corrosion of the heat exchanger and severely damage the heater. Heat exchanger damage resulting from chemical imbalance is not covered by the warranty.

For your health and the protection of your pool equipment, it is essential that your water be chemically balanced. The following levels must be used as a guide for balanced water.

Occasional chemical shock dosing of the pool or spa should not damage the heater providing the water is balanced.

Automatic chemical dosing devices and salt chlorinators are usually more efficient in heater water, unless controlled, they can lead to excessive chlorine level which can damage your heater.

Recommended Level(s)	Fiberglass Pools	Fiberglass Spas	Other Pool and Spa Types
Water Temperature	68-88°F (20-31°C)	89-104°F (31-40°C)	68-104°F (20-40°C)
pH	7.3-7.4	7.3-7.4	7.6-7.8
Total Alkalinity (ppm)	120-150	120-150	80-120
Calcium Hardness (ppm)	200-300	150-200	200-400
Salt (ppm)	6000 Maximum	6000 Maximum	6000 Maximum
Free Chlorine (ppm)*	2-3	2-3	2-3
Total Dissolved Solids (ppm)	3000 Maximum	3000 Maximum	3000 Maximum

*Free Chlorine **MUST NOT EXCEED 5 ppm!**

Table H: Water Chemistry

Further advice should be obtained from your pool or spa builder, accredited pool shop, or chemical supplier for the correct levels for your water.

Automatic Chlorinators and Chemical Feeders

All chemicals must be introduced and completely diluted into the pool or spa water before being circulated through the heater. Do not place sanitizing chemicals in the skimmer. High chemical concentrations will result when the pump is not running (e.g. overnight).

Chlorinators must feed downstream of the heater and have an anti-siphoning device to prevent chemical back-up into the heater when the pump is shut off.

NOTE: High chemical concentrates from feeders and chlorinators that are out of adjustment will cause rapid corrosion to the heat exchanger. Such damage is not covered under the warranty.

NOTE: Failure of a heat exchanger due to lime scale build-up on the heating surface, low pH or other chemical imbalance is non-warrantable.

Gas Supply

DANGER: Make sure the gas on which the heater will operate is the same type as specified on the heater's rating plate.

Gas piping **must** have a sediment trap ahead of the heater gas controls, **and** a manual shut-off valve located outside the heater jacket. It is recommended that a union be installed in the gas supply piping adjacent to the heater for servicing. The gas supply pressure to the heater must not exceed 10.5 in. WC for Natural Gas or 13.0 in. WC for Propane Gas. A pounds-to-inches regulator must be installed to reduce the gas supply pressure if it is higher than noted above. This regulator should be placed a minimum distance of 10 times the pipe diameter upstream of the heater gas controls. Refer to Table I for maximum pipe lengths.

Gas Supply Connection

CAUTION: The heater must be disconnected from the gas supply during any pressure testing of the gas supply system at test pressures in excess of 1/2 psi (3.45 kPa).

The heater must be isolated from the gas supply piping system by closing the upstream manual shut-off valve during any pressure testing of the gas supply piping system at test pressures equal to or less than 1/2 psi (3.45 kPa). Relieve test pressure in the gas supply line prior to reconnecting the heater and its manual shut-off valve to the gas supply line. **FAILURE TO FOLLOW THIS PROCEDURE MAY DAMAGE THE GAS VALVE.** Over-pressurized gas valves are not covered by warranty. The heater and its gas connections shall be leak-tested before placing the appliance in operation. Use soapy water for leak test. **DO NOT** use an open flame.

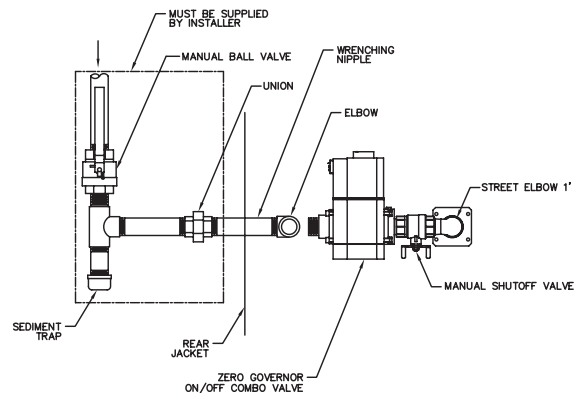

Fig. 15: Gas Supply Connection

CAUTION: Do not use Teflon tape on gas line pipe thread. A pipe compound rated for use with natural and propane gases is recommended. Apply sparingly only on male pipe ends, leaving the two end threads bare.

CAUTION: Support gas supply piping with hangers, not by the heater or its accessories. Make sure the gas piping is protected from physical damage and freezing, where required.

Gas Supply Pressure

A minimum of 4.0 in. WC and a maximum of 10.5 in. WC upstream gas pressure is required under load and no-load conditions for natural gas. A minimum of 4.0 in. WC and a maximum of 13.0 in. WC is required for propane gas. The gas pressure regulator(s) supplied on the heater is for low-pressure service. If upstream pressure exceeds these values, an intermediate gas pressure regulator, of the lockup type, must be installed.

When connecting additional gas utilization equipment to the gas piping system, the existing piping must be checked to determine if it has adequate capacity for the combined load.

Model No.	1 in. NPT		1-1/4 in. NPT		1-1/2 in. NPT		2 in. NPT		2-1/2 in. NPT	
	N	P	N	P	N	P	N	P	N	P
504	15	35	65	150	150	360				
754	5	15	35	75	70	175	250			
1104			15	35	35	75	100	250	225	
1504			10	20	20	45	60	150	150	275
2004							35	85	85	200

Natural Gas – 1,000 BTU/ft³, 0.60 specific gravity at 0.5 in. WC pressure drop
Propane Gas – 2,500 BTU/ft³, 1.53 specific gravity at 0.6 in. WC pressure drop

Table I: Maximum Equivalent Pipe Length

The gas valve pressure regulator on the heater is nominally preset as noted in Table J.

During normal operation, carbon dioxide should be 8.0 to 9.0% at full fire for natural gas and between 9.0 and 10.0% for propane gas. Carbon monoxide should be <100ppm.

Model No.	Manifold Gas Pressure (High Fire Values)	
	Natural Gas	Propane Gas
504	-0.1	-0.1
754	-0.4	-0.1
1104	-1.0	-0.2
1504	-2.4	-0.6
2004	-2.0	-1.5

NOTE: Manifold pressures should be ±0.2 in. WC.

Table J: Manifold Gas Pressure Settings

Electrical Power Connections

Installations must follow these codes:

- National Electrical Code and any other national, state, provincial or local codes or regulations having jurisdiction.
- Safety wiring must be NEC Class 1.
- Heater must be electrically grounded as required by the NEC.
- In Canada, CSA C22. 1 C.E.C. Part 1.

The MVB 504-1504 heaters are wired for 120 VAC, 12 amps while the MVB 2004 heaters are wired for 120 VAC, 18 amps. Consult the wiring diagram shipped with the heater. Before starting the heater, check to ensure proper voltage to the heater and pump.

Boiler mounted pumps (up to ¼ hp) get their power supply directly from the boiler power supply (connections in rear wiring box). Install a circuit breaker sized sufficiently for both the heater and the pump. Pumps larger than ¼ hp must use a separate power supply and run the power through the optional pump contactor which is located in the rear wiring box. Use appropriately-sized wire as defined by NEC, CSA and/or local codes. All primary wiring should be 125% of minimum rating.

If any of the original wire as supplied with the heater must be replaced, it must be replaced with 105°C wire or its equivalent.

All field wiring connections to the MVB heater are made inside the rear wiring box as shown in Fig. 16. Pump power should be taken from terminals 2 (Com), 3 (GND) and 6 (Hot) – ¼ hp and smaller ONLY. Power to the MVB heater should be connected to terminals 1, 2, and 3 as noted in Fig. 16. Sensors, interlocks, Enable/disable, and various options are wired into terminals 1 – 12 as noted in Fig. 16.

Field-Connected Controllers

It is strongly recommended that all individually-powered control modules and the heater should be supplied from the same power source.

NOTE: Field-supplied isolation relays should be installed when field-connected controllers are mounted more than 50 equivalent feet (18 Ga) from heater.

Check the Power Source

WARNING: Using a multi-meter, check the following voltages at the circuit breaker panel prior to connecting any equipment. Make sure proper polarity is followed and house ground is proven. (See Fig. 17.)

Combustion Air Supply	Exhaust Configuration	Heater Venting Category	Certified Materials	Combustion Air Inlet Material
From Inside Building (Non-Direct Venting)	Vertical Venting	I	B-Vent Equivalent	
	Horizontal Through-the-Wall Venting	III	Stainless Steel AL29-4C	
From Outside Building (Direct Venting)	Vertical Venting	I	B-Vent Equivalent	Galvanized Steel PVC ABS CPVC
	Horizontal Through-the-Wall Venting	III	Stainless Steel AL29-4C	

Table K: Venting Category Requirements

- Condensate can freeze on the vent cap. Frozen condensate on the vent cap can result in a blocked flue condition.
- Give special attention to the location of the vent termination to avoid possibility of property damage or personal injury.
- Gases may form a white vapor plume in winter. The plume could obstruct a window view if the termination is installed near windows.
- Prevailing winds, in combination with below-freezing temperatures, can cause freezing of condensate and water/ice build-up on buildings, plants or roofs.
- The bottom of the vent terminal and the air intake shall be located at least 12 in. above grade, including normal snow line.
- Un-insulated single-wall metal vent pipe shall not be used outdoors in cold climates for venting gas-fired equipment.
- Through-the-wall vents for Category II and IV appliances and non-categorized condensing appliances shall not terminate over public walkways or over an area where condensate or vapor could create a nuisance or hazard or could be detrimental to the operation of regulators, relief valves, or other equipment. Where local experience indicates that condensate is a problem with Category I and III appliances, this provision shall also apply.
- Locate and guard vent termination to prevent accidental contact by people or pets.
- DO NOT terminate vent in window well, stairwell, alcove, courtyard or other recessed area.
- DO NOT terminate above any door, window, or gravity air intake. Condensate can freeze, causing ice formations.
- Locate or guard vent to prevent condensate from damaging exterior finishes. Use a rust-resistant sheet metal backing plate against brick or masonry surfaces.
- DO NOT extend exposed vent pipe outside of building. Condensate could freeze and block vent pipe.

U.S. Installations

Refer to the latest edition of the National Fuel Gas Code.

Vent termination requirements are as follows:

- Vent must terminate at least 4 ft below, 4 ft horizontally from or 1 ft above any door, window or gravity air inlet to the building.
- The vent must not be less than 7 ft above grade when located adjacent to public walkways.
- Terminate vent at least 3 ft above any forced air inlet located within 10 ft.
- Vent must terminate at least 4 ft horizontally, and in no case above or below unless 4 ft horizontal distance is maintained, from electric meters, gas meters, regulators, and relief equipment.
- Terminate vent at least 6 ft away from adjacent walls.
- DO NOT terminate vent closer than 5 ft below roof overhang.

7. The vent terminal requires a 12 in. vent terminal clearance from the wall.
8. Terminate vent at least 1 ft above grade, including normal snow line.
9. Multiple direct vent installations require a 4 ft clearance between the ends of vent caps located on the same horizontal plane.

WARNING: The Commonwealth of Massachusetts requires that sidewall vented heaters, installed in every dwelling, building or structure used in whole or in part for residential purposes, be installed using special provisions as outlined on page 53 of this manual.

Canadian Installations

Refer to latest edition of the B149 Installation code.

A vent shall not terminate:

1. Directly above a paved sidewalk or driveway which is located between two single-family dwellings and serves both dwellings.
2. Less than 7 ft (2.13 m) above a paved sidewalk or paved driveway located on public property.
3. Within 6 ft (1.8 m) of a mechanical air supply inlet to any building.
4. Above a meter/regulator assembly within 3 ft (915 mm) horizontally of the vertical centre-line of the regulator.
5. Within 6 ft (1.8 m) of any gas service regulator vent outlet.
6. Less than 1 ft (305 mm) above grade level.
7. Within the 3 ft (915 mm) of a window or door which can be opened in any building, any non-mechanical air supply inlet to any building or the combustion air inlet of any other appliance.
8. Underneath a verandah, porch or deck, unless the verandah, porch or deck is fully open on a minimum of two sides beneath the floor, and the distance between the top of the vent termination and the underside of the verandah, porch or deck is greater than 1 ft (305 mm).

Venting Installation Tips

Support piping:

- horizontal runs - at least every 5 ft
- vertical runs - use braces
- under or near elbows

WARNING: Examine the venting system at least once a year. Check all joints and vent pipe connections for tightness, corrosion or deterioration.

Venting Configurations

For heaters connected to gas vents or chimneys, vent installations shall be in accordance with the NFGC (U.S.), or B149 (Canada), or applicable provisions of local building codes.

Natural Draft Vertical Venting (Category I)

Installation

Natural draft venting uses the natural buoyancy of the heated flue products to create a thermal driving head that expels the exhaust gases from the flue. The negative draft must be within the range of -.01 to -.08 in. WC as measured 12 in. above the appliance flue outlet to ensure proper operation. Vent material must be listed by a nationally recognized test agency.

The maximum and minimum venting length for Category I appliances shall be determined per the NFGC (U.S.) or B149 (Canada).

The diameter of vent flue pipe should be sized according to the NFGC (U.S.) and B149 (Canada).

The connection from the appliance vent to the stack must be as direct as possible. The horizontal breaching of a vent must have an upward slope of not less than 1/4 inch per linear foot from the heater to the vent terminal. The horizontal portions of the vent shall also be supported for the design and weight of the material employed to maintain clearances and to prevent physical damage or separation of joints.



more than one heater to a com-
sized to handle the combined
guides for proper sizing of the
ey. At no time should the area
e less than the area of the
outlet.

Common venting systems may be t
existing unit is removed. At the time
existing appliance, **the following ste**
lowed with each appliance remaining
common venting system placed in op
other appliances remaining connecte
venting system are not in operation

1. Seal any unused opening
system.
2. Visually inspect
and

system. Turn on any exhaust fans, such as range hoods and bathroom exhausts, at maximum speed. Do not operate summer exhaust fan. Close fireplace dampers.

4. Place in operation the appliances being inspected. Follow the manufacturer's instructions for lighting each appliance. Adjust thermostat so appliance will operate continuously.
5. Check the pressure at a pressure tap located 12 in. above the bottom joint of the first vertical vent pipe. Pressure should be anywhere between -0.01 and -0.08 in. WC.
6. After it has been determined that each appliance remaining connected to the common venting system properly vents when tested as outlined above, return doors, windows, exhaust fans, fireplace dampers and other gas burning appliances to their previous conditions of use.
7. Any improper operation of the common venting system should be corrected so that the installation conforms with the NFGC (U.S.) or B149 (Canada). When re-sizing any portion of the common venting system, the common venting system should be re-sized to approach the minimum size as determined using the appropriate tables in Appendix G in the NFGC (U.S.) or B149 (Canada).

Model No.	Vent Size (in.)	Volume of Flue Products (CFM)
504	8	170

NOTE: Data for 100% firing rate.

Table M: Volume of Flue Products Data

Engineered Vent Systems

Table M provides boiler discharge vent volumes of flue products at full fire for the calculation of appropriate vent sizing for common venting.

WARNING: Vent connectors serving any other appliances shall not be connected into any portion of mechanical draft systems operating under a positive pressure. If an MVB heater is installed to replace an existing heater, the vent system **MUST** be verified to be of the correct size and Category. If it is **NOT**, it **MUST** be replaced.

NOTE: For extractor sizing, typical CO₂ levels are 8.5% for natural gas and 9.5% for LP gas and flue temperature of 350° F.

NOTE: While a drain connection is required in the vent of all Cat. III horizontal MVB installations, the drain can be accomplished in several different ways. The figures in this manual show the drain in a vent tee, however, this can also be accomplished using an inline collector for condensing stacks or an inline vertical or horizontal collector available from several of the listed vent manufacturers.

- 75' of straight flue pipe
- 65' of straight flue pipe and one elbow
- 55' of straight flue pipe and two elbows
- 45' of straight pipe and three elbows

The vent cap is not considered in the overall length of the venting system.

The vent must be installed to prevent flue gas leakage. Care must be taken during assembly to ensure that all joints are sealed properly and are airtight. The vent must be installed to prevent the potential accumulation of condensate in the vent pipes. It is required that:

1. The vent must be installed with a condensate drain located in proximity to the heater as directed by the vent manufacturer.
2. The vent must be installed with a slight upward slope of not less than 1/4 inch per foot of horizontal run to the vent terminal.
3. The vent must be insulated through the length of the horizontal run.

Termination

The flue direct vent cap MUST be mounted on the exterior of the building. The direct vent cap cannot be installed in a well or below grade. The direct vent cap must be installed at least 1 ft above ground level and above normal snow levels. The Raypak-approved stainless steel flue direct vent cap must be used (sales order option D-15). The vent terminal must be located NO CLOSER than 12" off the wall.

WARNING: No substitutions of flue pipe or vent cap material are allowed. Such substitutions would jeopardize the safety and health of inhabitants.

Direct Vent - Vertical

Installation

These installations utilize the heater-mounted blower to draw combustion air from outdoors and force the heated flue products through the vent pipe under positive pressure. The vent material must be in accordance with the above instructions for vent materials. Vent material must be listed by a nationally recognized test agency.

The connection from the appliance flue to the stack must be as direct as possible and should be the same size or larger than the vent outlet.



Model No.	Certified Vent Material	Vent Size (in.)	Horizontal Vent Height ¹ (ft)*		Combustion Air Intake Pipe Material	Air Inlet Max. Length ^{**} (ft)		
			Min.	Max.		6" Ø	8" Ø	10" Ø
504	Category III	8	0	75	Galvanized Steel, PVC, ABS, CPVC	45	100	
754		10						
1104		10						
1504		12				45	85	
2004		14						

* Vent lengths are based on a lateral length of 2 ft. Refer to the latest edition of the NFGC for further details.

** Subtract 10 ft per elbow. Max. 4 elbows.

Table N: Category III Horizontal Vent & Horizontal Direct Vent

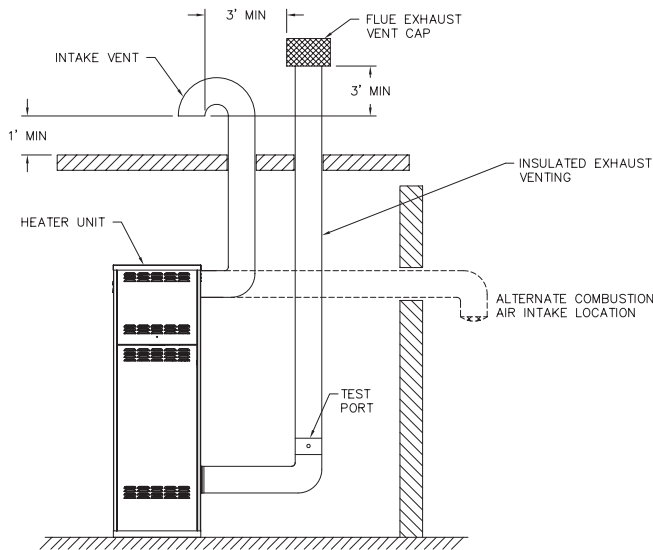

Fig. 25: Direct Vent - Vertical

See Table L for Category I venting guidelines.

It is recommended that the intake vent be insulated in colder climates.

Termination

The flue terminal should be vertical and should terminate outside the building at least 2 ft above the highest point of the roof within 10 ft. The vent cap should have a minimum clearance of 4 ft horizontally from and in no case above or below (unless a 4 ft horizontal distance is maintained) electric meters, gas meters, regulators and relief equipment. The distance of the vent terminal from adjacent public walkways, adjacent buildings,

open windows and building openings must be consistent with the NFGC (U.S.) or B149 (Canada).

Flues supported only by flashing and extended above the roof more than 5 ft should be securely guyed or braced to withstand snow and wind loads.

The air inlet opening **MUST** be installed 1 ft above the roof line or above normal snow levels that might obstruct combustion air flow. This dimension is critical to the correct operation of the heater and venting system and reduces the chance of blockage from snow. The vent cap must have a minimum 3 ft vertical clearance from the air inlet opening.

Outdoor Installation

Outdoor models must be vented with listed vent material per the following instructions and installed with the optional factory-supplied outdoor vent kit. A special vent cap and air intake hood are provided in accordance with CSA requirements. These must be installed as illustrated in Fig. 26.

Care must be taken when locating the heater outdoors, because the flue gases discharged from the vent cap can condense as they leave the cap. Improper location can result in damage to adjacent structures or building finish. For maximum efficiency and safety, the following precautions must be observed:

1. Outdoor models must be installed outdoors and must use the outdoor vent cap, flow switch cover and air intake hood available from the manufacturer (sales order option D-11).

2. Periodically check venting system. The heater's venting areas must never be obstructed in any way and minimum clearances must be observed to prevent restriction of combustion and ventilation air. Keep area clear and free of combustible and flammable materials.
3. Do not locate adjacent to any window, door walkway, or gravity air intake. The vent must be located a minimum of 4 ft horizontally from such areas.
4. Install above grade level and above normal snow levels.
5. Vent terminal must be at least 3 ft above any forced air inlet located within 10 ft.
6. Adjacent brick or masonry surfaces must be protected with a rust-resistant sheet metal plate.

Freeze Protection

The Raypak electronic temperature control includes a freeze protection feature. In the event the temperature drops below 40° F at any of the boiler temperature sensors, the pump is turned on and will remain on until the temperature at all boiler sensors rises to 45° F.

Controls

The Raypak electronic temperature control is provided to maintain the desired system water temperature. The control has various modes of operation which are listed below.

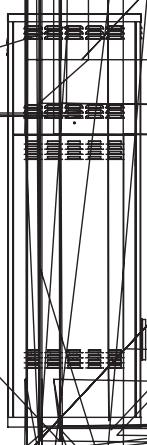

Operating Modes

Mode 1 – (H7 and WH1 models) Setpoint operation using primary piping. The heater outlet water temperature is controlled to the boiler target setpoint. See Fig. 27.

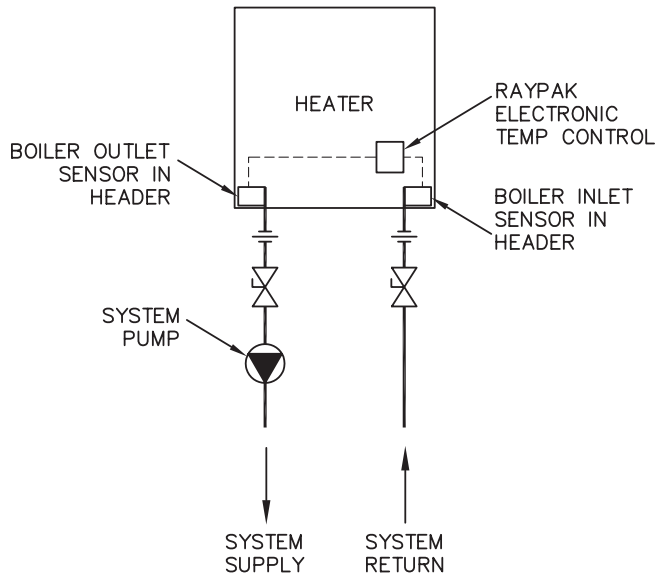

Fig. 27: Mode 1 Primary Piping

Mode 2 – Setpoint operation using primary/secondary piping. The control operates the heater to satisfy a remote system sensor. The heater is turned off based on boiler max and boiler differential (factory default H7, P and WHP boilers). See Fig. 28.

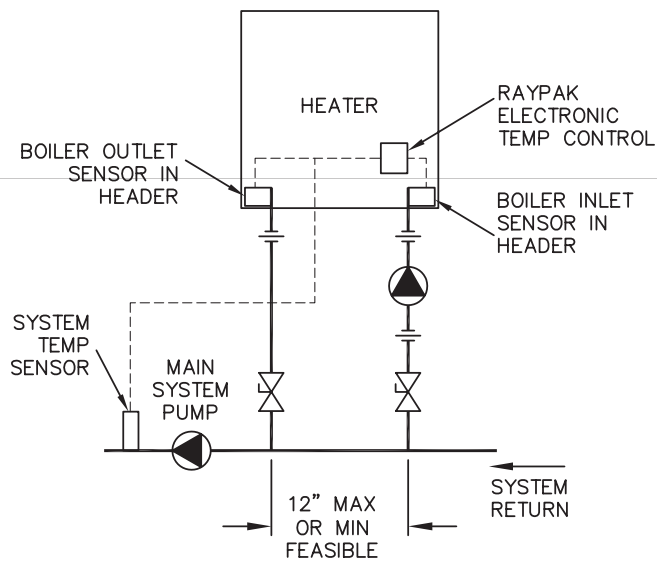

Fig. 28: Mode 2 Primary/Secondary Piping

Mode 3 – Dedicated DHW operation using UniTemp 80 piping. A call for heat is determined by the DHW sensor and the DHW boiler target. The heater outlet water is also controlled to the boiler target temperature (factory default WH1 water heaters). See Fig. 29.

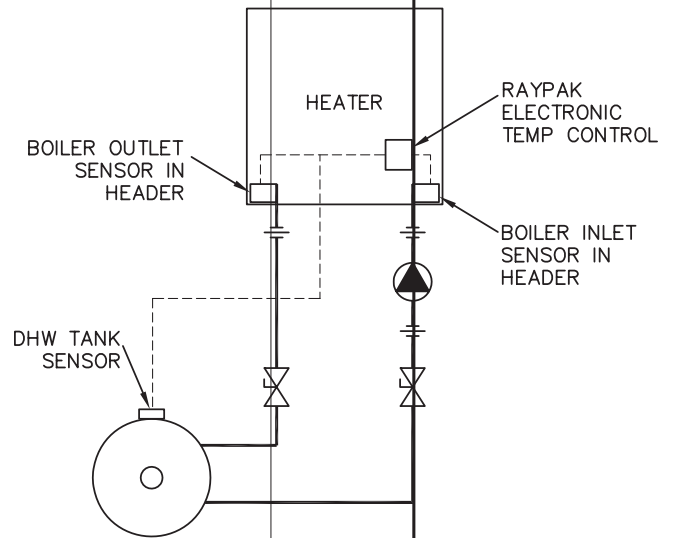

Fig. 29: Mode 3 Dedicated DHW

Mode 4 – Outdoor reset using primary piping. The heater is operated as in Mode 1. However the target temperature is based on outdoor reset. See Fig. 30.

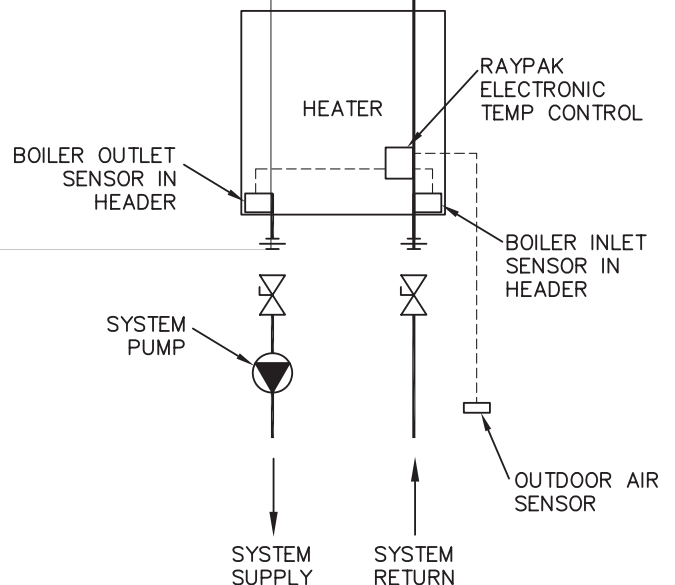

Fig. 30: Mode 4 Primary Piping with Outdoor Reset

Mode 5 – Outdoor reset using primary/secondary piping. The heater is operated as in Mode 2. However, the target temperature is based on outdoor reset. See Fig. 31.

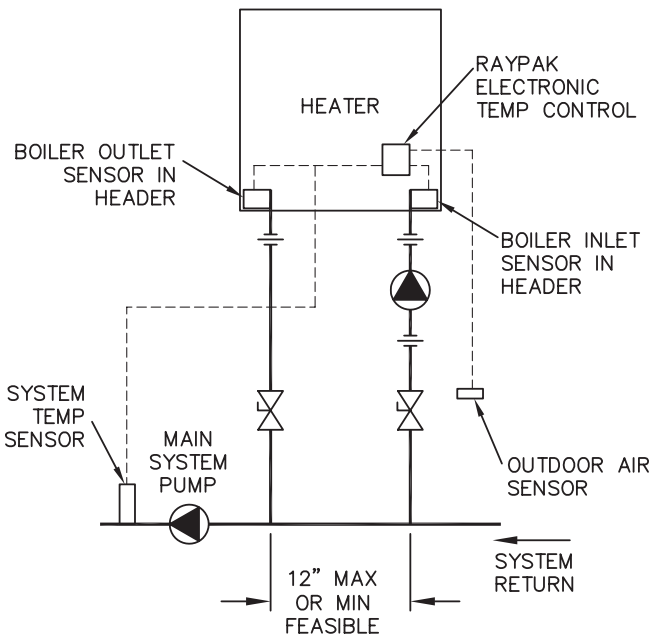

Fig. 31: Mode 5 Primary/Secondary Piping with Outdoor Reset

Mode 6 – Designed for an external input signal with primary piping. The external input signal can be provided from a BMS, an EMS or a sequencing control. The external input signal changes the boiler target according to a linear scale. The control operates the

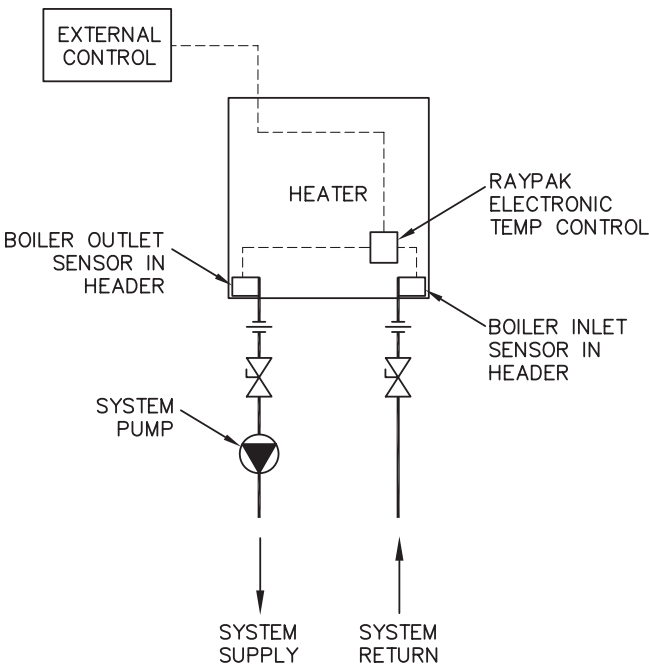

Fig. 32: Mode 6 Primary Piping with External Target Temp

boiler burner to maintain the boiler target at the boiler outlet sensor. See Fig. 32.

Mode 7 – Designed for an external input signal with primary/secondary piping. The external input signal can be provided from a BMS, an EMS or a sequencing control. The external input signal changes the boiler target according to a linear scale. The control operates the boiler burner to maintain the boiler target at the remote system sensor. See Fig. 33.

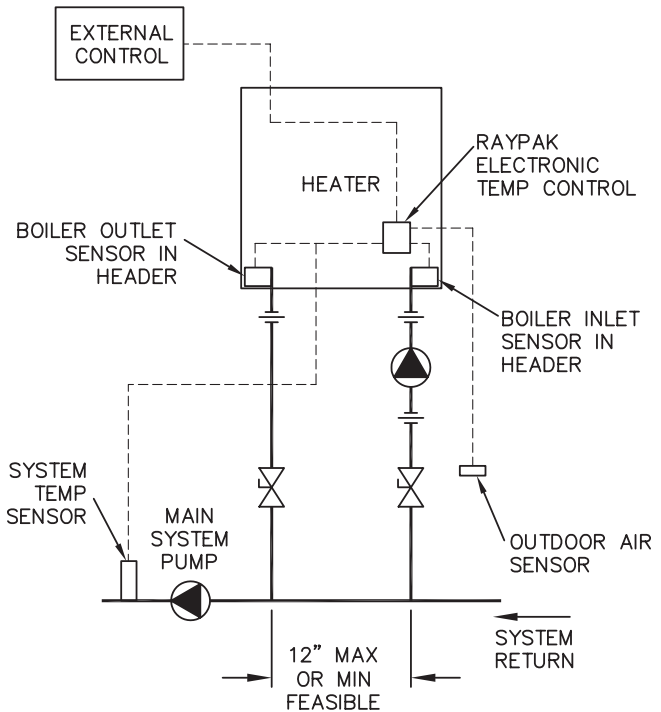

Fig. 33: Mode 7 Primary/Secondary Piping with External Target Temp

Mode 8 – This mode is used for remote control mode. The Boil Max setting is the heater shutdown temperature.

Boiler (H7)			
Item	Modes	Default Setting	Range
Boil Target	1, 2	140°F	OFF, 70 to 220°F
	3	160°F	OFF, 70 to 190°F
	4, 5, 6, 7	180°F	OFF, 70 to 220°F
Boil Max	1, 2, 4, 5, 6, 7, 8	200°F	OFF, 120 to 225°F
	3	180°F	OFF, 120 to 190°F
Boil Min	1, 2, 3, 4, 5, 6, 7	135°F	OFF, 80 to 180°F
'Burner' Delay	All	0:00 min	0:00 to 3:00 min
Boil Mass	All	1 (Low)	1 (Low), 2 (Med), 3 (High)
Diff	1, 2, 3, 4, 5, 6, 7	Auto	Auto, 2 to 42°F
DHW Target	3	120°F	OFF, 70 to 190°F
DHW Diff	3	5°F	2 to 10°F
'Pump' Dly	All	3:00 min	OFF, 0:20 to 9:55 min, ON
Outdr Start	4, 5	70°F	35 to 85°F
Outdr Design	4, 5	-10°F	-60 to 32°F
Boil Start	4, 5	135°F	35 to 150°F
Boil Dsgn	4, 5	180°F	120 to 220°F
WWSD	4, 5	70°F	35 to 100°F
Units	All	°F	°F or °C
Mode	N/A	2	1, 2, 3, 4, 5, 6, 7, 8
External Input Signal	6, 7	2 to 10 VDC	2 to 10 VDC or 0 to 10 VDC
Offset	6, 7	0°F	-10°F to 10°F

Table O: Temperature Control Default Setpoints—Boiler

Pool Heater (P, WHP)			
Item	Modes	Default Setting	Range
Boil Target	2	78°F	OFF, 45 to 106°F
Boil Max	2	86°F	OFF, 70 to 106°F
Boil Min	2	70°F	OFF, 45 to 106°F
'Burner' Delay	All	0:00 min	0:00 to 3:00 min
Boil Mass	All	1 (Low)	1 (Low), 2 (Med), 3 (High)
Diff	2	1°F	1 to 3°F
'Pump' Dly	All	3:00 min	OFF, 0:20 to 9:55 min, ON
Units	All	°F	°F or °C
Mode	N/A	2	2

Table P: Temperature Control Default Setpoints—Pool Heater

Water Heater (WH1)			
Item	Modes	Default Setting	Range
Boil Target	1, 2	140°F	OFF, 70 to 190°F
	3, 6, 7	160°F	OFF, 70 to 190°F
Boil Max	1, 2, 3, 6, 7	180°F	OFF, 120 to 190°F
Boil Min	1, 2, 3, 6, 7	135°F	OFF, 80 to 180°F
'Burner' Delay	All	0:00 min	0:00 to 3:00 min
Boil Mass	All	1 (Low)	1 (Low), 2 (Med), 3 (High)
Diff	1, 2, 3, 6, 7	Auto	Auto, 2 to 42°F
DHW Target	3	120°F	OFF, 70 to 190°F
DHW Diff	3	5°F	2 to 10°F
'Pump' Dly	All	3:00 min	OFF, 0:20 to 9:55 min, ON
Units	All	°F	°F or °C
Mode	N/A	3	1, 2, 3, 6, 7
External Input Signal	6, 7	2 to 10 VDC	2 to 10 VDC or 0 to 10 VDC
Offset	6, 7	0°F	-10°F to 10°F

Table Q: Modulating Temperature Control Default Setpoints—Water Heater

Definitions

NOTE: The defined terms are not active in all modes of control operation.

% OUT - Current percent modulation rate of heater.

BOIL DSGN - Design boiler water temperature used in heat loss calculations.

BOIL MASS - This setting allows adjustment in the field for high or low thermal masses; High thermal mass (setting=3) provides slower reaction, lower thermal mass (setting=1) provides faster reaction.

BOIL MAX - Highest outlet water temperature that the control is allowed to use as a target temperature.

BOIL MIN - Lowest outlet water temperature that the control is allowed to use as a target temperature.

BOIL ON - Accumulated runtime of heater (up to 999 hours, then resets to 0).

BOIL OUT - Actual heater outlet water temperature.

BOIL START - Starting boiler water temperature.

BOIL SUP - Actual system supply water temperature.

BOIL TARGET - Target temperature that the heater is trying to maintain.

'BURNER' DELAY - Holds control output at ignition setting from the start of the ignition sequence to the specified burner delay time (0 to 3:00 min.).

DEM 1 - Indicates 24 VDC signal has been supplied to the H+D terminal.

DEM 2 - Indicates 24 VDC Flame Proof signal is present.

DIFF - The operating differential of the heater; The heater outlet water temperature is allowed to rise above the BOIL TARGET temperature by ½ of this differential before the heater shuts off. For example, if the heater target temperature is set to 160°F (71°C) and the differential is set to 10°F (5°C), on temperature rise, the heater will shut off at 165°F (74°C). Once the heater shuts off, it will not come on again until the temperature falls to 155°F (68°C).

EXTERNAL INPUT SIGNAL - Selects external input signal range (0-10VDC or 2-10VDC):

Rank	Item Field	Number Field	Type	Fault Description
0	E01	Err	Error	EEPROM error
1	FP	Err	Warning	Flame proof warning
2	BOIL OUT	SHr	Error	Boiler outlet sensor short
3	BOIL OUT	OPn	Error	Boiler outlet sensor open
4	BOIL IN	SHr	Error	Boiler inlet sensor short
5	BOIL IN	OPn	Error	Boiler inlet sensor open
6	SUP	SHr	Error	System sensor short
7	SUP	OPn	Error	System sensor open
8	OUTDR	SHr	Error	Outdoor sensor short
9	OUTDR	OPn	Error	Outdoor sensor open
10	DHW	SHr	Error	DHW sensor short
11	DHW	OPn	Error	DHW sensor open

Table R: Error Codes

0-10VDC or 0-20 mA external input signal – When the 0-10VDC signal is selected, an input voltage of 1 VDC corresponds to a boiler target temperature of 50°F (10°C). An input voltage of 10 VDC corresponds to a boiler target temperature of 220°F (104°C). As the voltage varies between 1 VDC and 10 VDC, the boiler target temperature varies linearly between 50°F (10°C) and 220°F (104°C). If a voltage below 0.5 VDC is received, the boiler target temperature is displayed as “— — —” indicating that there is no longer an internal heat demand. A 0-20 mA signal can be converted to a 0-10 VDC signal by installing a 500 Ω resistor on the external input signal device’s terminals.

2-10VDC or 4-20 mA external input signal – When the 2-10VDC signal is selected, an input voltage of 2 VDC corresponds to a boiler target temperature of 50°F (10°C). An input voltage of 10 VDC corresponds to a boiler target temperature of 220°F (104°C). As the voltage varies between 2 VDC and 10 VDC, the boiler target temperature varies linearly between 50°F (10°C) and 220°F (104°C). If a voltage below 1.5 VDC is received, the boiler target temperature is displayed as “— — —” indicating that there is no longer an internal heat demand. A 4-20 mA signal can be converted to a 2-10 VDC signal by installing a 500 Ω resistor on the external input signal device’s terminals.

FP - Flame proof warning.

MODE - Operating mode of the heater.

OFFSET - The Offset setting allows the boiler target temperature to be fine tuned to the external input signal. The control reads the external input signal and converts this to a boiler target temperature. The Offset setting is then added to the boiler target temperature.

OUTDR - Outdoor air temperature.

OUTDR DESIGN - Design outdoor air temperature used in the heat loss calculation.

OUTDR START - Starting outdoor air temperature.

PUMP DLY - Sets the operating time of the pump once the CFH is satisfied.

TANK - Current DHW tank temperature (Mode 3).

TANK DIFF - Storage tank differential (Mode 3).

TANK TARGET - Target temperature in the DHW storage tank (Mode 3).

UNITS - Selects the temperature units to be displayed (°F or °C).

WWSD - Selects the outdoor temperature that shuts the heater off, no matter what the demand. NOTE: The WWSD segment is displayed on the LCD.

Operation

The Raypak electronic temperature control uses a Liquid Crystal Display (LCD) as a method of supplying information. The LCD is used to setup and monitor system operation by means of three push buttons (*Item*, ▲ and ▼) shown at the bottom of Fig. 34.

All items displayed by the control are organized into two menus, the view menu and the adjust menu. The active menu is displayed in the upper right hand side of the display in the menu field. The default menu is the view menu.

When the temperature control is powered up, the control turns on all segments in the display for 2 seconds, then the software version is displayed for 2 seconds. At the end of that 4 second period, the control enters the normal operating mode and "VIEW" is displayed. Pressing the scroll button "scrolls" through the displayed values in the "VIEW" menu.

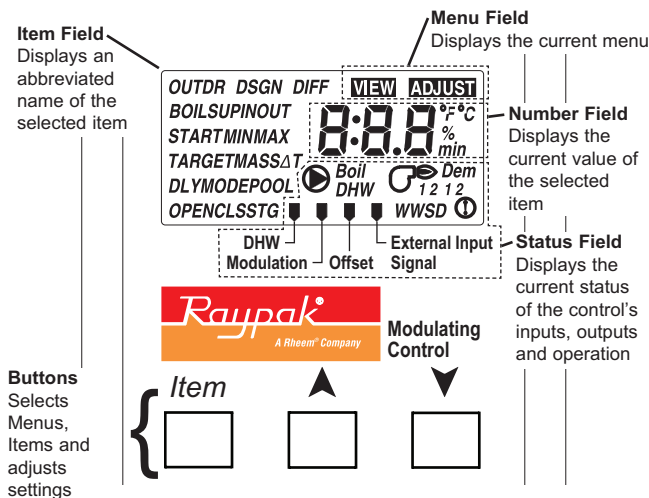

Fig. 34: Modulating Temperature Control Display

To make an adjustment to a setting in the control, begin by selecting the "ADJUST" menu. To change from the view menu to the adjust menu, simultaneously press and hold all three buttons for 1 second. The menu name, "ADJUST" will be displayed in the menu field.

The menu will automatically revert back to the view menu after 20 seconds of keyboard inactivity. Then scroll to the desired item using the scroll button. Finally, use the ▲ or ▼ button to make the adjustment. In the absence of other information, the values provided in Tables O, P and Q should be used as default settings.

Heater Sequence of Operation

Models 504–2004

1. The black (hot) wire lead, located at the right-middle front inside the control compartment, goes directly to the main power switch.
2. When the main power switch is placed in the "ON" position, the 120 VAC terminal block in the control compartment, the N.O. contacts of pump relay, the N.O. contacts of blower relay, the 120/24 VAC transformer, and terminals L1 and F1 of the ignition module are powered.
3. The 120/24 VAC transformer sends a 24 VAC hot power signal to the 24V Terminal Block.
4. 24 VAC is sent from the 24V Terminal Block to the NO pump contacts on the modulating temperature control (pin #13), to pin TP2 of the optional alarm relay, to terminal R of the alarm circuit on the modulating temperature control (pin #24) and the green "Power On" LED on the front of the heater will illuminate.
5. 24 VAC power is sent from 24V Terminal Block to Pin P1-1 of the UDB board, the 24 VAC terminal of the ignition control module, the common contact of the manual high limit, pin P3-1 of the UDB board and L1 of the Low Water Cut Off (if equipped).
6. A 24 VAC signal is sent from the NC contact of the manual high limit to the common terminal of the Blocked Vent Switch and to Pin P1-1 of the UDB board. During a blocked vent condition a 24 VAC signal is sent from the NO open contacts of the Blocked Vent Switch to pin P3-5 of the UDB board to indicate a safety fault.
7. During normal operation of the heater the 24 VAC signal exits the NC contacts of the Blocked Vent Switch and is sent to the common terminal of the Low Gas Pressure Switch (if equipped). During a low gas pressure condition 24 VAC is sent from the NC contacts of the Low Gas Pressure Switch to pin P3-6 of the UDB board to indicate a safety fault.
8. 24 VAC is sent from the NO contacts of the Low Gas Pressure Switch to the common terminal of the High Gas Pressure Switch (if equipped). During a high gas pressure condition 24 VAC is sent from the NO contacts of the High Gas Pressure Switch to pin P3-7 of the UDB board to indicate a safety fault.

-
9. 24 VAC is sent from the NC contact of the High Gas Pressure Switch to the common terminal of the Low Water Cut Off (if equipped). Upon loss of water in the heater, the Low Water Cut Off (if equipped) will send a 24VAC signal to pin P3-4 of the UDB board to indicate a safety fault.
 10. 24VAC is sent from the NO contact of the Low Water Cut Off to the common contact of the Auto Reset High Limit (if equipped) and energizes the coil of the alarm relay. If the Auto Hi Limit opens, 24 VAC is sent from the NO contacts of the Auto Hi Limit to pin P3-3 of the UDB board to indicate a safety fault.
 11. 24 VAC is sent from the NC contacts of the Auto Reset Hi Limit to the common terminal of the burner switch located on the front exterior panel of the heater.
 12. When the burner switch is closed, 24VAC power then travels from the NO contact of the burner switch to the remote enable/disable connection at terminal 11 of the rear j-box low voltage terminal block and to the NO contact of the Enable/Disable relay.
 13. When 24VAC power is returned from terminal 12 of the rear j-box low voltage terminal block to the coil of the Enable/Disable relay, the relay contacts close, and 24VAC is transmitted to the Ht D (heat demand) connection of the modulating temperature control and to the stage contact of the modulating temperature control (pin#15 for P and WHP models or pin#17 for H and WH models).
 14. When the stage contact closes on the modulating temperature control, 24 VAC is sent to the common terminal of the flow switch and to pin P1-3(CFH) of the UDB board. In addition, the amber "Call-for-Heat" LED on the front of the heater will illuminate.
 15. The pump contact on the modulating temperature control closes sending 24 VAC to the pump switch located on the front exterior panel of the heater.
 16. When the pump switch is closed, 24 VAC is sent to the coil of the pump relay.
 17. The pump relay energizes and closes the contacts, starting the heater pump.
 18. Upon sufficient flow, the flow switch closes and sends 24 VAC to the common terminal of the air pressure switch and the TH terminal of the ignition module. If the flow switch does not close, a 24 VAC signal is sent to pin P4-9 of the UDB board to indicate an insufficient flow condition.
 19. When 24 VAC is received at TH on the ignition module, the contacts between pins F1 and F2 close and send 120 VAC to pin 1 of the blower relay.
 20. The coil of the blower relay energizes closing the NO contacts sending 120 VAC to energize the combustion air blower motor.
 21. Once sufficient air flow is proven the air pressure switch closes the NO contacts, 24 VAC is sent to the heater interlock connection at terminal 9 of the rear j-box low voltage terminal block. If air pressure is insufficient or lost during heater operation a 24VAC signal is sent from the NC contacts of the air pressure switch to pin P4-10 of the UDB board to indicate insufficient air pressure.
 22. When 24VAC is returned to terminal 10 of the rear j-box low voltage terminal block, power then travels to the P Switch terminal of the ignition module. The ignition module employs a 15 second pre-purge before the next sequence.
 23. After 15 seconds of combustion chamber pre-purge, pin S1 sends 120 VAC to the Hot Surface Igniter.
 24. The Hot Surface Igniter will be energized for approximately 30 seconds and must exceed 3.1 amp draw during heat up.
 25. Once the ignition module determines the proper operation of the Hot Surface Igniter, a 24 VAC signal is output from the Valve pin on the module to energize the gas valve.
 26. The gas valve is energized and the blue "Burner On" LED on the front of the heater energizes.
 27. The remote sensor is now trying to rectify the flame. If the flame is not rectified within 4 seconds, the ignition module will shut down the gas valve and lock out.
 28. When burner flame is rectified, the heater will operate based on the electronic operating control. In the event of an ignition lockout, the ignition module sends a signal to pin P4-12 (ignition lockout) of the UDB board.
 29. When the CFH is satisfied, the heater will return to a standby condition awaiting the next CFH.
-

The optional adjustable manual reset high limit is located inside the heater junction box. Push the reset button and adjust the setting to approx. 40°F (20°C) above desired outlet temperature.

High Limit - Auto Reset (Optional)

The heater may be equipped with an optional adjustable auto reset high limit temperature device.

The optional adjustable auto reset high limit is located inside the heater junction box. Adjust the setting to approx. 20°F (10°C) above desired outlet temperature.

Modulating Temperature Control

The heater is equipped with a Raypak modulating temperature control. Refer to information starting on page 31 for information on the setting and use of this control.

Low Water Cut-Off (Optional)

The optional low water cut-off automatically shuts down the burner whenever water level drops below the level of the sensing probe. A 5-second time delay prevents premature lockout due to temporary conditions such as power fluctuations or air pockets.

Flow Switch

This standard, dual-purpose control, mounted and wired in series with the main gas valve, shuts off heater in case of pump failure or low water flow.

High and Low Gas Pressure Switches (Optional)

The optional low gas pressure switch connection mounts upstream of the gas valve (on the inlet flange to the gas valve) and is accessible through the removable access panels on the rear of the heater to reset the gas pressure switch, as necessary. It is used to ensure that sufficient gas pressure is present for prop-

er valve/regulator performance. The low gas pressure switch automatically shuts down the heater if gas supply drops below the factory setting of 3.0 in. WC for natural gas or LP gas.

The optional high gas pressure switch connection mounts down-stream of the gas valve. Special ports are located on the backside of the gas valve and accessible from the front of the heater (to reset the gas pressure switch) or through the removable access panels on the rear of the heater (to reset the gas pressure switch), as necessary. If the gas pressure regulator in the valve fails, the high gas pressure switch automatically shuts down the burner.

Operation of either the High or Low Gas Pressure Switch will turn on an LED inside the switch housing. Push the top of the plastic switch housing as shown in Fig. 41 to reset a tripped pressure switch. The white LED will glow out when the switch is reset.

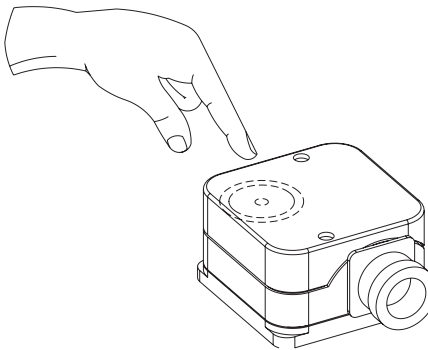

Fig. 41: High/Low Gas Pressure Switch

Air Pressure Switch

The heater is equipped with an air pressure switch to prove the operation of the blower before allowing the ignition control to begin a Call for Heat. It is located on the right side of the lower flange of the blower mounting assembly, directly behind the junction box.

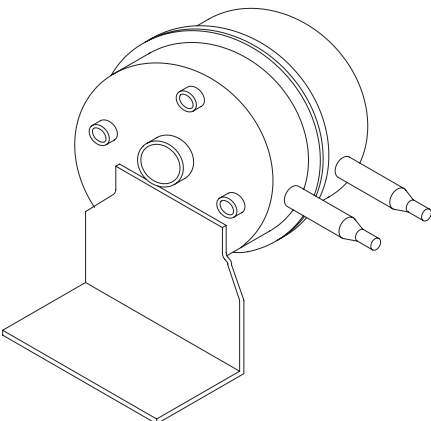

Fig. 42: Air Pressure Switch

Blocked Vent Switch

This heater is equipped with a blocked vent pressure switch to prevent the operation of the heater when too much of the vent is blocked. This switch is located on the right side of the heater near the right rear corner.

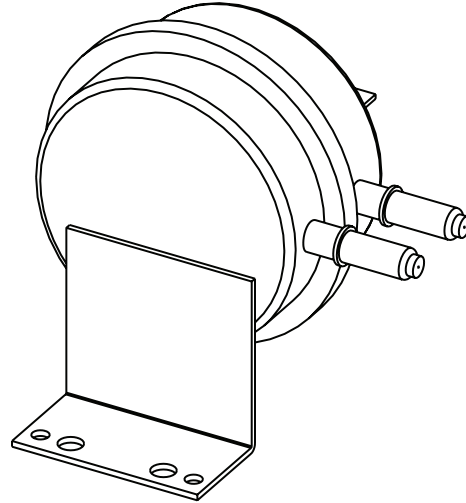

Fig. 43: Blocked Vent Switch

UDB Diagnostic Board

This heater is equipped with a diagnostic board which will indicate faults as they occur. It has the ability to retain up to 256 faults in history. Refer to the Troubleshooting section for instructions on accessing, reviewing and clearing these faults.

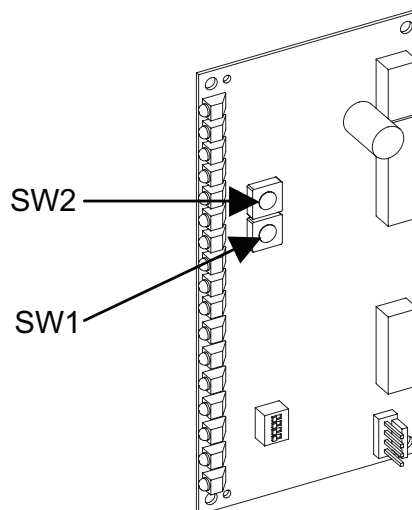

Fig. 44: UDB Diagnostic Board

START-UP

Pre Start-up

Filling System (Heating Boilers)

Fill system with water. Purge all air from the system. Lower system pressure. Open valves for normal system operation, and fill system through feed pressure. Manually open air vent on the compression tank until water appears, then close vent.

Air Purge (Domestic Hot Water Heaters)

Purge all air from system before lighting heater. This can be normally accomplished by opening a downstream valve.

Raypak offers an optional air vent for the MVB heaters which can be screwed directly into the inlet side of the header to ensure that air is purged from the system. This option also includes an adapter to allow the air vent to be piped (in the field) to a suitable drain as required by the jurisdiction having authority.

CAUTION: An air vent should be installed at the highest point in the system for proper operation. If water piping is located higher than the header, it should be relocated to the highest point in the installed system.

Venting System Inspection

1. Check all vent pipe connections and flue pipe material.
2. Make sure vent terminations are installed per code and are clear of all debris or blockage.

For Your Safety

WARNING: If you do not follow these instructions exactly, a fire or explosion may result causing property damage, personal injury or loss of life.

This appliance has a hot surface igniter. It is equipped with an ignition device which automatically lights the burners. Do not try to light the burners by hand.

BEFORE OPERATING, smell all around the appliance area for gas. Be sure to smell near the floor because some gas is heavier than air and will settle on the floor.

WHAT TO DO IF YOU SMELL GAS:

- Do not try to light any appliance.
- Do not touch any electrical switch; do not use any telephone in your building.
- Immediately call your gas supplier from a neighbor's telephone. Follow the gas supplier's instructions.
- If you cannot reach your gas supplier, call the fire department.
- Use only your hand to push in or turn the gas control knob. Never use tools. If the knob will not turn by hand, do not try to repair it, call a qualified service technician. Forced or attempted repair may result in a fire or explosion.
- Do not use this appliance if any part has been under water, immediately call a qualified service technician to inspect the appliance and to replace any part of the control system and any gas control which has been under water.
- Check around unit for debris and remove combustible products, i.e. gasoline, etc.

Pre Start-up Check

1. Verify the heater is filled with water.
2. Check system piping for leaks. If found, repair immediately.
3. Vent air from system. Air in system can interfere with water circulation.
4. Purge air from gas line to heater.

Initial Start-up

Required tools

- (1) 12-0-12 (24" scale) U-tube manometer
- (2) 6-0-6 (12" scale) U-tube manometer
- Screwdrivers (assorted sizes and shapes)
- (1) Crescent wrench (8" or 10")
- (1) Multi-meter
- (1) Amp probe

(Metric Allen wrenches will be required for servicing the gas valve, but not during start-up)

NOTE: Digital manometers are not recommended.

Preparation

WARNING: Do not turn on gas at this time.

Check Power Supply

With multi-meter at incoming power, check voltage between:

Hot - Common (≈ 120 VAC)

Hot - Ground (≈ 120 VAC)

Common - Ground (< 1 VAC)

WARNING: If Common - Ground is > 1 VAC, STOP: Contact electrician to correct ground failure. Failure to do this may burn out 120V-24V transformer, or may cause other safety control damage or failure.

Attach Manometers to Measure Pressures

1. Turn off main gas valve.
2. Attach (1) 12" scale manometer to an upstream bleedle valve on the gas supply pipe to the heater (Measure point "A" in Fig. 45).
3. Attach (1) 24" scale manometer to the manifold pressure tap located on the valve (Measure point "D" in Fig. 45).
4. Attach (1) 12" scale manometer near the fan-proving switch. Pull black cap from air pressure switch tee and connect the manometer. NOTE: Retain caps for reinstallation later.

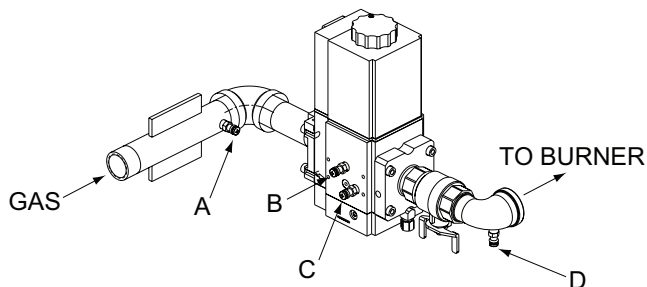

Fig. 45: Gas Pressure Measurement Location

Check Gas Supply Pressure

1. Slowly turn on main gas shut-off valve.
2. Read the gas supply pressure from the manometer; minimum supply pressure for natural gas is 4.0 in. WC, recommended supply is 7.0 in. WC, minimum supply pressure for propane gas is 4.0 in. WC, recommended supply is 11.0 in. WC (dynamic readings, full fire input).

3. If the gas pressure is greater than 14.0 in. WC, turn off the main gas shut-off valve.

Start-Up

NOTE: The values in Tables T, U and V represent the conditions when the heater is at full firing rate at sea level.

1. Turn power on.
2. Turn on the heater, wait approximately 15 seconds after the blower starts, and the igniter should start to glow (observable through the observation port located at the front, bottom of the heater). Look into the sight glass located at the bottom of the front panel to check igniter operation. Gas valve should open in 45-60 seconds.
3. The heater ignites at 50% of full rate (as indicated on the LCD display of the temperature controller located in the upper right of the front panel).
4. If the burner fails to light on the first trail, it will go into lockout with the standard ignition module. If the heater is equipped with the optional three-try ignition module, it will try for ignition up to three times before going into lockout.
5. Wait until the controller indicates 100% on the firing rate display screen (approximately 30 seconds).

Blower Check

1. Check blower suction using the manometer attached to the fan pressure switch tee, with the heater firing at 100% input. The reading should be as noted in Table T for both natural and propane gas.
2. Measure the blower amp draw and compare the measured value to the values in Table U for reference only. If the measured value is substantially different ($\pm 20\%$ + of Table U values), contact the factory.

NOTE: Connect the amp probe to the 14-gauge black power wire going into the blower.

Manifold Check

1. Check manifold gas pressure at the gas valve outlet pressure tap (connection "D" in Fig. 45). This pressure should read per the values in Table V for natural and propane gas.

- If the pressure reading differs by more than ± 0.2 in. WC, **STOP – Call the factory for directions on what to do next!**

Model No.	Air Pressure Setting (in. WC)	Setting Tolerance
504	-2.3	± 0.2 in. WC
754	-2.9	± 0.2 in. WC
1104	-3.0	± 0.2 in. WC
1504	-4.0	± 0.2 in. WC
2004	-5.1	± 0.2 in. WC

Table T: MVB Air Pressure Settings

Model No.	Amp Draw	Setting Tolerance
504	1.9	+0.0/-0.2
754	2.9	+0.0/-0.2
1104	4.8	+0.0/-0.2
1504	8.1	+0.0/-0.2
2004	13.0	+0.0/-0.5

Table U: MVB Amp Draw (Reference Only)

Model No.	Manifold Gas Pressure Setting High Fire Values (in. WC)	
	Natural Gas	Propane Gas
504	-0.1	-0.1
754	-0.4	-0.1
1104	-1.0	-0.2
1504	-2.4	-0.6
2004	-2.0	-1.5

Table V: MVB Manifold Pressure Settings

CAUTION: Special manifold and air settings may be required.

Finishing

- Record all data on the “Start-up Sheet” located at the back of the Installation and Operating manual.
- Disconnect the manometers and reconnect the cap on the fan pressure switch tee and reinsert the sealing screws into the bleedle valves.
- Start-up is complete and the heater should be operating properly.

Safety Inspection

- Check all thermostats and high limit settings.
- During the following safety checks leave manometers hooked up, check and record.
- If other gas-fired appliances in the room are on the same gas main, check all pressures on the MVB with all other equipment running.
- Check thermostats for ON-OFF operation.
- Check high limits for ON-OFF operation.
- While in operation, check flow switch operation.
- Check the low gas pressure switch (if provided). (For proper adjustment, use the attached manometers, if available, to set pressure. The scales on the switch are approximate only.) Low gas pressure switch (if provided) must be set at 3.0 in. WC for natural gas and propane gas.
- Make sure that the high gas pressure switch (optional) is set to 3.0 in. WC for both natural gas and propane gas.

Follow-Up

Safety checks must be recorded as performed. Turn heater on. After main burner ignition:

- Check manometer for proper readings.
- Cycle heater several times and re-check readings.
- Remove all manometers and replace caps and screws.
- Check for gas leaks one more time.

Leak Test Procedure: Dual-Seat Gas Valve

Proper leak testing requires three pressure test points in the gas train.

Remove the access panel on the rear of the heater to access the gas valve for this test. Test point A is a bleedle valve located upstream of the combination gas valve on the supply manifold.

Test point B is a bleedle valve located between the two automatic gas valve seats.

Test point C is a bleedle valve located downstream of both automatic gas valve seats and upstream of the manual valve. Refer to Fig. 46.

These tests are to be conducted with the electrical power to the heater turned OFF.

1. Manually close the downstream leak test valve.
2. Open the bleedle valve at test point A and connect a manometer to it. Verify that there is gas pressure and that it is within the proper range (NOTE: must not exceed 14.0 in. WC).
3. Open test point B and connect a rubber tube to it. Connect the other end of the tube to a manometer and look for a build-up of pressure. Increasing pressure indicates a leaking gas valve which must be replaced.
4. Next, close the upstream manual gas valve (field supplied) and remove the manometers from the bleedle valves in test point A and test point B. Connect a rubber tube from the test point A bleedle valve to the test point B bleedle valve and open the upstream manual gas valve. Make sure that test point A & B bleedle valves have been opened so as to allow gas to flow. This will bring gas pressure to the second valve seat.
5. Open the bleedle valve at test point C and connect a second rubber tube to it. Connect the other end of the tube to a manometer and look for a build-up of pressure. Increasing pressure indicates a leaking gas valve which must be replaced.
6. Remove rubber tube and manometers. Close each test point bleedle valve as the tubes are removed.

7. After no leakage has been verified at all valve seats and test valves, open downstream leak test valve and restore electrical power to the heater.

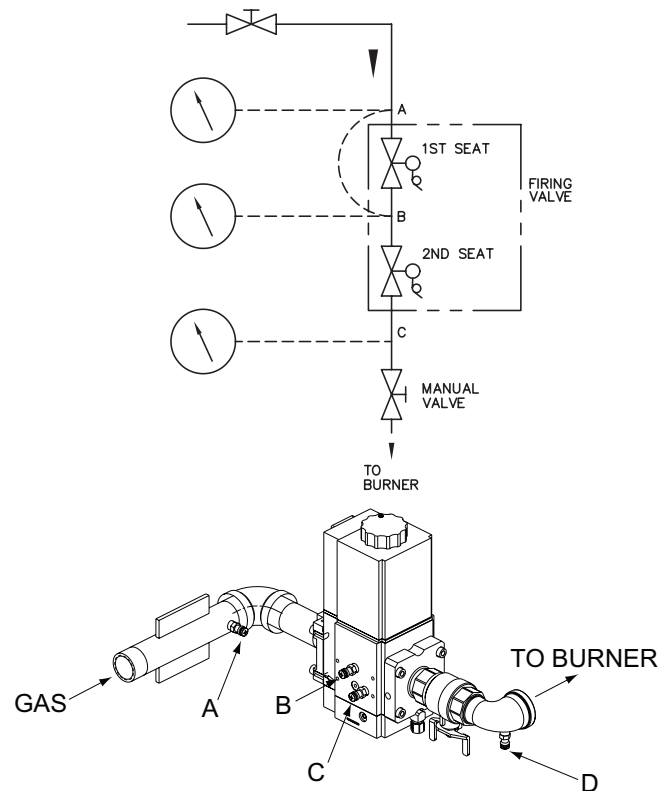

Fig. 46: Leak Test Procedure

Post Start-Up Check

Check off steps as completed:

1. Verify that the heater and heat distribution units or storage tank are filled with water.
2. Confirm that the automatic air vent (if used) was opened two full turns during the venting procedure.
3. Verify that air has been purged from the system.
4. Verify that air has been purged from the gas piping, and that the piping has been checked for leaks.
5. Confirm that the proper start-up procedures were followed.
6. Inspect burner to verify flame.
7. Test safety controls: If heater is equipped with a low water cut-off or additional safety controls, test

for operation as outlined by manufacturer. Burner should be operating and should go off when controls are tested. When safety devices are restored, burners should re-ignite after pre-purge time delay.

8. Test limit control: While burner is operating, move indicator on high limit control below actual water temperature. Burner should go off while blower and circulator continue to operate. Raise setting on limit control above water temperature and burner should re-ignite after pre-purge time delay. **NOTE: Ignition control may have to be reset after this portion of the test.**
9. Test ignition system safety device:
 - a. Open manual gas valve. Turn power on.
 - b. Set thermostat to call for heat.
 - c. When the heater is in operation, pull cap off of tee in air switch hose. The burner should go off almost immediately.
 - d. Reattach cap on tee. Burner should re-ignite after pre-purge time delay. **NOTE: Ignition control may have to be reset after this portion of the test.**
10. To restart system, follow lighting instructions in the Operation section.
11. Check to see that the high limit control is set above the design temperature requirements of the system. For multiple zones: Check to make sure the flow is adjusted as required in each zone.
12. Check that the heater is cycled with the thermostat. Raise the setting on the thermostat to the highest setting and verify that the heater goes through the normal start-up cycle. Reduce to the lowest setting and verify that the heater goes off.
13. Observe several operating cycles for proper operation.
14. Set the heater thermostat to desired temperature.
15. Review all instructions shipped with this heater with owner or maintenance person, return to envelope and give to owner or place the instructions inside front panel on heater.

OPERATION

Lighting Instructions

1. Before lighting, make sure you have read all of the safety information in this manual.
2. Remove upper front panel.
3. Set the thermostat to the lowest setting.
4. Turn off all electrical power to the appliance.
5. This appliance is equipped with an ignition device which automatically lights the burner. Do not try to light the burner by hand.
6. Turn on main manual gas valve field installed near gas inlet connection on back of heater.
7. Wait 5 minutes to clear out any gas. Then smell for gas, especially near the floor. If you then smell gas, STOP! Follow the steps in the safety information on the front cover of this manual. If you do not smell gas, go to next step.
8. Turn on all electrical power to the appliance.
9. Set thermostat to desired setting. The appliance will operate. The igniter will glow after the pre-purge time delay (15 seconds). After igniter reaches temperature (30 seconds) the main valve should open. System will try for ignition up to three times (one time on optional single-try ignition module). If flame is not sensed, lockout will commence.
10. If the appliance will not operate, follow the instructions "To Turn Off Gas To Appliance," and call your service technician or gas supplier.
11. Replace upper front panel.
12. If heater fails to start, verify the following:
 - a. There are no loose connections or that the service switch is off.
 - b. High temperature limit switch is set above water temperature or manual reset high limit is not tripped.
 - c. Thermostat is set above water temperature.

-
- d. Gas is on at the meter and the heater.
 - e. Incoming dynamic gas pressure to the gas valve is NOT less than 4.0 in. WC for natural gas or propane gas.

To Turn Off Gas To Appliance

1. Shut off manual gas valve field installed near gas inlet connection on back of heater.
2. Remove upper front panel.
3. Set the thermostat to lowest setting.
4. Turn off all electrical power to the appliance if service is to be performed.
5. Replace access panel.

TROUBLESHOOTING

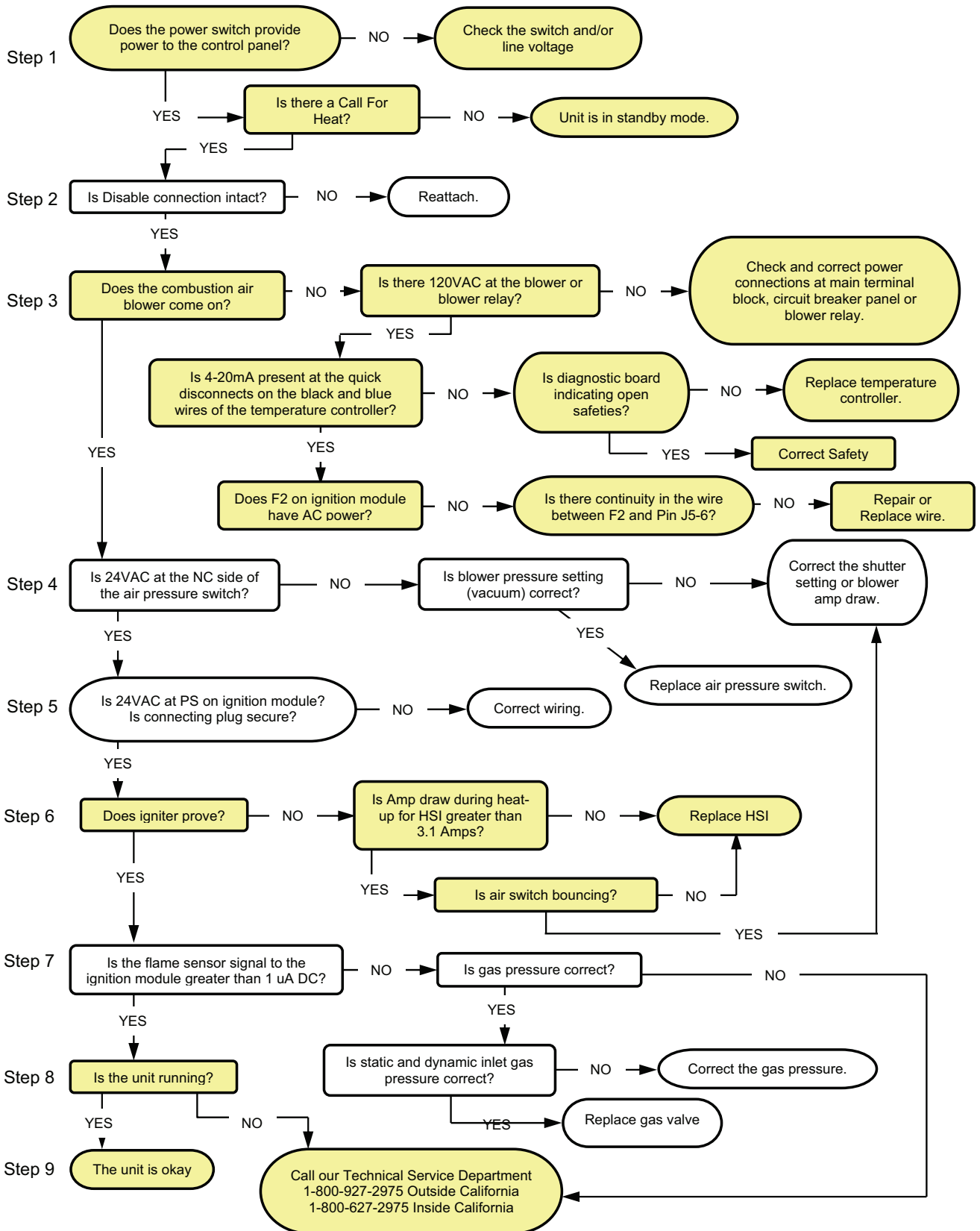

UDB Fault History

To view the fault codes in the UDB history file:

1. Press and hold the switch labeled “SW1” for 5 seconds to access the fault history. LED 17 will begin to flash when the history has been accessed. See Fig. 44 on page 40.
2. Press the switch labeled “SW2” to scroll through the recorded faults in history.
3. When a fault is being displayed, the corresponding LED will light and LED 17 will flash at a rate that corresponds to the fault number.
4. The faults are recorded and displayed on a last in, first out basis. The last fault recorded will be the first fault displayed. There is no time or date stamp associated with these faults.
5. Continue to push “SW2” to view subsequent faults.
6. When the history of faults has been exhausted, pushing “SW2” again will roll the fault history over and it will start again.
7. To exit the fault history, press and hold “SW1” for 5 seconds, or wait for 4 minutes and the board will automatically exit the history mode (fault LEDs will go out).

To clear the fault history, press and hold both “SW1” and “SW2” for 5 seconds while the power is on.

NOTE: Once the history has been cleared, it cannot be recovered.

MAINTENANCE

Suggested Minimum Maintenance Schedule

Regular service by a qualified service agency and maintenance must be performed to ensure maximum operating efficiency.

Maintenance as outlined below may be performed by the owner.

Daily

1. Check that the area where the heater is installed is free from combustible materials, gasoline, and other flammable vapors and liquids.
2. Check for and remove any obstruction to the flow of combustion or ventilation air to heater.

Monthly

1. Check for piping leaks around pumps, mixing valves, relief valves, and other fittings. If found, repair at once. DO NOT use petroleum-based stop-leak compounds.
2. Visually inspect burner flame.
3. Visually inspect venting system for proper function, deterioration or leakage.
4. Visually inspect for proper operation of the condensate drain in the venting. If leaks are observed repair at once.
5. Check air vents for leakage.

Yearly (Beginning Of Each Heating Season)

Schedule annual service call by qualified service agency.

1. Visually check top of vent for soot. Call service person to clean. Some sediment at bottom of vent is normal.
2. Visually inspect venting system for proper function, deterioration or leakage. Ensure that condensate drain is inspected and ensure that condensate is being directed to appropriate condensate management system or drain, as required

by local codes.

3. Check that area is free from combustible materials, gasoline, and other flammable vapors and liquids.
4. Check for and remove any obstruction to the flow of combustion or ventilation air to heater.
5. Follow pre-start-up check in the Start-up section.
6. Visually inspect burner flame. It should be light blue at full input. Remove and visually inspect hot surface igniter and sensor for damage, cracking or debris build-up.
7. Check operation of safety devices. Refer to manufacturers' instructions.
8. Follow oil-lubricating instructions on pump (if required). Over-oiling will damage pump. Water-lubricated circulators do not need oiling.
9. To avoid potential of severe burn, DO NOT REST HANDS ON OR GRASP PIPES. Use a light touch; return piping will heat up quickly.
10. Check blower and blower motor
11. Check for piping leaks around pumps, relief valves and other fittings. Repair, if found. DO NOT use petroleum-based stop-leak.

Periodically

1. Check relief valve. Refer to manufacturer's instructions on valve.
2. Test low water cut-off (if equipped). Refer to manufacturer's instructions.

Preventive Maintenance Schedule

The following procedures are recommended and are good practice for all MVB installations.

Daily

1. Check gauges, monitors and indicators.
2. Check instrument and equipment settings. (See "Post Start-Up Check" on page 46.)

3. Check burner flame. (Should see light blue flame at full input rate).

Weekly

For low-pressure heaters, test low-water cut-off device. (With heater in pre-purge, depress the low water cut-off test button. Appliance should shut-off and ignition fault light should come on. Depress reset button on front of heater control panel to reset).

Monthly

1. Check flue, vent, stack, or outlet dampers.
2. Test blower air pressure. (See "Blower Check" on page 44.)
3. Test high and low gas pressure interlocks (if equipped). (See "Safety Inspection" on page 45.)

Semi-Annually

1. Recalibrate all indicating and recording gauges.
2. Check flame failure detection system components.
3. Check firing rate control by checking the manifold pressure. (See "Manifold Check" on page 44.)
4. Check piping and wiring of all interlocks and shut-off valves.

Annually

1. Test flame failure detection system and pilot turn-down.
2. Test high limit and operating temperature. (See "Post Start-Up Check," page 46.)
3. Check flame sensor.
4. Conduct a combustion test at full fire. Carbon dioxide should be 8.0 to 9.0% at full fire for natural gas, and between 9.0 to 10.0% for propane gas. Carbon monoxide should be < 100 ppm.
5. Check valve coil for 60 cycle hum or buzz. Check for leaks at all valve fittings using a soapy water solution (while heater is operating). Test other operating parts of all safety shut-off and control valves and increase or decrease settings (depending on the type of control) until the safety circuit opens. Reset to original setting after each device is tested.

6. Perform leakage test on gas valves (See Fig. 46.) and procedure on page 46.
7. Test air switch in accordance with manufacturer's instructions. (Turn panel switch to the "On" position until blower is proven, then turn the switch to "Off.")
8. Inspect and clean burner using shop air.

As Required

1. Recondition or replace low water cut-off device (if equipped).
2. Check drip leg and gas strainers.
3. Check flame failure detection system. (See "Post Start-Up Check," page 46.)
4. Check igniter. (Resistance reading should be 42-70 ohms at ambient temperature).
5. Check flame signal strength. (Flame signal should be greater than 1 **microampere** as measured at the 2 pins on the upper left corner of the ignition control).
6. Check firing rate control by checking the manifold pressure. (See "Manifold Check" on page 44).
7. Test safety/safety relief valves in accordance with ASME Heater and Pressure Vessel Code Section IV.

APPENDIX

Inside Air Contamination

All heaters experience some condensation during start-up. The condensate from flue gas is acidic. Combustion air can be contaminated by certain vapors in the air which raise the acidity of the condensate. Higher acidity levels attack many materials including stainless steel, which is commonly used in high efficiency systems. The heater can be supplied with corrosion-resistant, non-metallic intake air vent material. You may, however, choose to use outside combustion air for one or more of these reasons:

1. Installation is in an area containing contaminants listed below which will induce acidic condensation.
2. You want to reduce infiltration into your building through openings around windows and doors.

3. You are using AL29-4C stainless steel vent pipe, which is more corrosion-resistant than standard metallic vent pipe. In extremely contaminated areas, this may also experience deterioration.

Products causing contaminated combustion air:

- spray cans containing chloro/fluorocarbons
- permanent wave solutions
- chlorinated waxes/cleaners
- chlorine-based swimming pool chemicals
- calcium chloride used for thawing
- sodium chloride used for water softening
- refrigerant leaks
- paint or varnish removers
- hydrochloric acid/muriatic acid
- cements and glues
- antistatic fabric softeners used in clothes dryers
- chloride-type bleaches, detergents, and cleaning solvents found in household laundry rooms
- adhesives used to fasten building products
- similar products

Areas where contaminated combustion air commonly exists:

- dry cleaning/laundry areas
- metal fabrication plants
- beauty shops
- refrigeration repair shops
- photo processing plants
- auto body shops
- plastic manufacturing plants
- furniture refinishing areas and establishments
- new building construction
- remodeling areas
- open pit skimmers

Check for areas and products listed above before installing heater. If found:

- remove products permanently, OR
- install unit in direct vent configuration.

Important Instructions for the Commonwealth of Massachusetts

The Commonwealth of Massachusetts requires compliance with regulation 248 CMR 4.00 and 5.00 for installation of through – the – wall vented gas appliances as follows:

(a) For all side wall horizontally vented gas fueled equipment installed in every dwelling, building or structure used in whole or in part for residential purposes, including those owned or operated by the Commonwealth and where the side wall exhaust vent termination is less than seven (7) feet above finished grade in the area of the venting, including but not limited to decks and porches, the following requirements shall be satisfied:

1. **INSTALLATION OF CARBON MONOXIDE DETECTORS.** At the time of installation of the side wall horizontal vented gas fueled equipment, the installing plumber or gasfitter shall observe that a hard wired carbon monoxide detector with an alarm and battery back-up is installed on the floor level where the gas equipment is to be installed. In addition, the installing plumber or gasfitter shall observe that a battery operated or hard wired carbon monoxide detector with an alarm is installed on each additional level of the dwelling, building or structure served by the side wall horizontal vented gas fueled equipment. It shall be the responsibility of the property owner to secure the services of qualified licensed professionals for the installation of hard wired carbon monoxide detectors

a. In the event that the side wall horizontally vented gas fueled equipment is installed in a crawl space or an attic, the hard wired carbon monoxide detector with alarm and battery back-up may be installed on the next adjacent floor level.

b. In the event that the requirements of this subdivision can not be met at the time of completion of installation, the owner shall have a period of thirty (30) days to comply with the above requirements; provided, however, that during said thirty (30) day period, a battery operated carbon monoxide detector with an alarm shall be installed.

2. **APPROVED CARBON MONOXIDE DETECTORS.** Each carbon monoxide detector as required in accordance with the above provisions shall comply with NFPA 720 and be ANSI/UL 2034 listed and IAS certified.

3. **SIGNAGE.** A metal or plastic identification plate shall be permanently mounted to the exterior of the building at a minimum height of eight (8) feet above grade directly in line with the exhaust vent terminal for the horizontally vented gas fueled heating appliance or equipment. The sign shall read, in print size no less than one-half (1/2) inch in size, "GAS VENT DIRECTLY BELOW. KEEP CLEAR OF ALL OBSTRUCTIONS".

4. **INSPECTION.** The state or local gas inspector of the side wall horizontally vented gas fueled equipment shall not approve the installation unless, upon inspection, the inspector observes carbon monoxide detectors and signage installed in accordance with the provisions of 248 CMR 5.08(2)(a)1 through 4.

(b) **EXEMPTIONS:** The following equipment is exempt from 248 CMR 5.08(2)(a)1 through 4:

1. The equipment listed in Chapter 10 entitled "Equipment Not Required To Be Vented" in the most current edition of NFPA 54 as adopted by the Board; and

2. Product Approved side wall horizontally vented gas fueled equipment installed in a room or structure separate from the dwelling, building or structure used in whole or in part for residential purposes.

(c) **MANUFACTURER REQUIREMENTS - GAS EQUIPMENT VENTING SYSTEM PROVIDED.** When the manufacturer of Product Approved side wall horizontally vented gas equipment provides a venting system design or venting system components with the equipment, the instructions provided by the manufacturer for installation of the equipment and the venting system shall include:

1. Detailed instructions for the installation of the venting system design or the venting system components; and

2. A complete parts list for the venting system design or venting system.

(d) **MANUFACTURER REQUIREMENTS - GAS EQUIPMENT VENTING SYSTEM NOT PROVIDED.** When the manufacturer of a Product Approved side wall horizontally vented gas fueled equipment does not provide the parts for venting the flue gases, but identifies "special venting systems", the following requirements shall be satisfied by the manufacturer:

1. The referenced "special venting system" instructions shall be included with the appliance or equipment installation instructions; and

2. The "special venting systems" shall be Product Approved by the Board, and the instructions for that system shall include a parts list and detailed installation instructions.

(e) A copy of all installation instructions for all Product Approved side wall horizontally vented gas fueled equipment, all venting instructions, all parts lists for venting instructions, and/or all venting design instructions shall remain with the appliance or equipment at the completion of the installation.



**LIMITED PARTS WARRANTY
MVB – TYPES H AND WH
MODELS 504-2004**

SCOPE

Raypak, Inc. ("Raypak") warrants to the original owner that all parts of this heater which are actually manufactured by Raypak will be free from failure under normal use and service for the specified warranty periods and subject to the conditions set forth in this Warranty. Labor charges and other costs for parts removal or reinstallation, shipping and transportation are not covered by this Warranty but are the owner's responsibility.

HEAT EXCHANGER WARRANTY

Domestic Hot Water

Five (5) years from date of heater installation. Includes copper heat exchanger with bronze waterways.

Ten (10) years from date of heater installation. Includes only cupro-nickel heat exchanger with bronze waterways.

Space Heating (Closed Loop System)

Ten (10) years from date of heater installation. Includes both cupro-nickel and copper heat exchanger with bronze waterways.

Thermal Shock Warranty

Twenty (20) years from date of heater installation against "Thermal Shock" (excluded, however, if caused by heater operation at large changes exceeding 150°F between the water temperature at intake and heater temperature, or operating at heater temperatures exceeding 230°F).

ANY OTHER PART MANUFACTURED BY RAYPAK

One (1) year warranty from date of heater installation, or eighteen (18) months from date of factory shipment based on Raypak's records, whichever comes first.

SATISFACTORY PROOF OF INSTALLATION DATE, SUCH AS INSTALLER INVOICE, IS REQUIRED. THIS WARRANTY WILL BE VOID IF THE HEATER RATING PLATE IS ALTERED OR REMOVED.

ADDITIONAL WARRANTY EXCLUSIONS

This warranty does not cover failures or malfunctions resulting from:

1. Failure to properly install, operate or maintain the heater in accordance with our printed instructions provided;
2. Abuse, alteration, accident, fire, flood and the like;
3. Sediment or lime build-up, freezing, or other conditions causing inadequate water circulation;
4. High velocity flow exceeding heater design rates;
5. Failure of connected systems devices, such as pump or controller;
6. Use of non-factory authorized accessories or other components in conjunction with the heater system;
7. Failing to eliminate air from, or replenish water in, the connected water system;
8. Chemical contamination of combustion air or use of chemical additives to water.

PARTS REPLACEMENT

Under this Warranty, Raypak will furnish a replacement for any failed part. The failed part must first be returned to Raypak if requested, with transportation charges prepaid, and all applicable warranty conditions found satisfied. The replacement part will be warranted for only the unexpired portion of the original warranty. Raypak makes no warranty whatsoever on parts not manufactured by it, but Raypak will apply any such warranty as may be provided to it by the parts manufacturer.

TO MAKE WARRANTY CLAIM

Promptly notify the original installer, supplying the model and serial numbers of the unit, date of installation and description of the problem. The installer must then notify his Raypak distributor for instructions regarding the claim. If either is not available, contact Service Manager, Raypak, Inc., 2151 Eastman Avenue, Oxnard, CA 93030 or call (805) 278-5300. In all cases proper authorization must first be received from Raypak before replacement of any part.

EXCLUSIVE WARRANTY - LIMITATION OF LIABILITY

This is the only warranty given by Raypak. No one is authorized to make any other warranties on Raypak's behalf. THIS WARRANTY IN LIEU OF ALL OTHER WARRANTIES, EXPRESS OR IMPLIED, INCLUDING BUT NOT LIMITED TO IMPLIED WARRANTIES OF MERCHANTABILITY AND FITNESS FOR A PARTICULAR PURPOSE. RAYPAK'S SOLE LIABILITY AND THE SOLE REMEDY AGAINST RAYPAK WITH RESPECT TO DEFECTIVE PARTS SHALL BE AS PROVIDED IN THIS WARRANTY. IT IS AGREED THAT RAYPAK SHALL HAVE NO LIABILITY, WHETHER UNDER THIS WARRANTY, OR IN CONTRACT, TORT, NEGLIGENCE OR OTHERWISE, FOR ANY SPECIAL, CONSEQUENTIAL, OR INCIDENTAL DAMAGE, INCLUDING DAMAGE FROM WATER LEAKAGE. Some states do not allow limitations on how long an implied warranty lasts, or for the exclusion of incidental or consequential damages. So the above limitation or exclusion may not apply to you.

This Limited Warranty gives you specific legal rights. You may also have other rights which may vary from state to state. We suggest that you complete the information below and retain this certificate in the event warranty service is needed. Reasonable proof of the effective date of the warranty (date of installation) must be presented, otherwise, the effective date will be based on the rate of manufacture plus thirty (30) days.

Original Owner

Model Number

Mailing Address

Serial Number

Date of Installation

City State Zip Code

Installation Site

Daytime Telephone Number

Contractor/Installer

RAYPAK, INC • 2151 Eastman Avenue • Oxnard, CA 93030-9786 • (805) 278-5300 • Fax (800) 872-9725 • www.raypak.com



**LIMITED PARTS WARRANTY
MVB – TYPE P & WHF
MODELS 504–2004**

SCOPE

Raypak, Inc. ("Raypak") warrants to the original owner that all parts of this heater which are actually manufactured by Raypak will be free from failure under normal use and service for the specified warranty periods and subject to the conditions set forth in this Warranty. Labor charges and other costs for parts removal or reinstallation, shipping and transportation are not covered by this Warranty but are the owner's responsibility.

HEAT EXCHANGER WARRANTY

Five (5) years from date of heater installation. Includes cupro-nickel heat exchanger with bronze and cast iron waterways.

Ten (10) years from date of heater installation. Includes only cupro-nickel heat exchanger with bronze or cast iron waterways.

Thermal Shock Warranty

Twenty (20) years from date of heater installation against "Thermal Shock" (excluded, however, if caused by heater operation at large changes exceeding 150°F between the water temperature at intake and heater temperature, or operating at heater temperatures exceeding 230°F).

ANY OTHER PART MANUFACTURED BY RAYPAK

One (1) Year warranty from date of heater installation, or eighteen (18) months from date of factory shipment based on Raypak's records, whichever comes first.

SATISFACTORY PROOF OF INSTALLATION DATE, SUCH AS INSTALLER INVOICE, IS REQUIRED. THIS WARRANTY WILL BE VOID IF THE HEATER RATING PLATE IS ALTERED OR REMOVED.

ADDITIONAL WARRANTY EXCLUSIONS

This warranty does not cover failures or malfunctions resulting from:

1. Failure to properly install, operate or maintain the heater in accordance with our printed instructions provided;
2. Abuse, alteration, accident, fire, flood and the like;
3. Sediment or lime build-up, freezing, or other conditions causing inadequate water circulation;
4. High velocity flow exceeding heater design rates;
5. Failure of connected systems devices, such as pump or controller;
6. Use of non-factory authorized accessories or other components in conjunction with the heater system;
7. Chemical contamination of combustion air or use of chemical additives to water.
8. Misuse or neglect, including but not limited to freeze-ups, operating the heater with cabinet door off, having flow restrictions or obstructions between the heater outlet and pool/spa or not maintaining proper chemical balance (pH level must be between 7.2 and 7.8 and total alkalinity between 100 and 150 PPM. Total Dissolved Solids (TDS) must be no greater than 2500 PPM).

PARTS REPLACEMENT

Under this Warranty, Raypak will furnish a replacement for any failed part. The failed part must first be returned to Raypak if requested, with transportation charges prepaid, and all applicable warranty conditions found satisfied. The replacement part will be warranted for only the unexpired portion of the original warranty. Raypak makes no warranty whatsoever on parts not manufactured by it, but Raypak will apply any such warranty as may be provided to it by the parts manufacturer.

TO MAKE WARRANTY CLAIM

Promptly notify the original installer, supplying the model and serial numbers of the unit, date of installation and description of the problem. The installer must then notify his Raypak distributor for instructions regarding the claim. If either is not available, contact Service Manager, Raypak, Inc., 2151 Eastman Avenue, Oxnard, CA 93030 or call (805) 278-5300. In all cases proper authorization must first be received from Raypak before replacement of any part.

EXCLUSIVE WARRANTY - LIMITATION OF LIABILITY

This is the only warranty given by Raypak. No one is authorized to make any other warranties on Raypak's behalf. THIS WARRANTY IN LIEU OF ALL OTHER WARRANTIES, EXPRESS OR IMPLIED, INCLUDING BUT NOT LIMITED TO IMPLIED WARRANTIES OF MERCHANTABILITY AND FITNESS FOR A PARTICULAR PURPOSE. RAYPAK'S SOLE LIABILITY AND THE SOLE REMEDY AGAINST RAYPAK WITH RESPECT TO DEFECTIVE PARTS SHALL BE AS PROVIDED IN THIS WARRANTY. IT IS AGREED THAT RAYPAK SHALL HAVE NO LIABILITY, WHETHER UNDER THIS WARRANTY, OR IN CONTRACT, TORT, NEGLIGENCE OR OTHERWISE, FOR ANY SPECIAL, CONSEQUENTIAL, OR INCIDENTAL DAMAGE, INCLUDING DAMAGE FROM WATER LEAKAGE. Some states do not allow limitations on how long an implied warranty lasts, or for the exclusion of incidental or consequential damages. So the above limitation or exclusion may not apply to you.

This Limited Warranty gives you specific legal rights. You may also have other rights which may vary from state to state. We suggest that you complete the information below and retain this certificate in the event warranty service is needed. Reasonable proof of the effective date of the warranty (date of installation) must be presented, otherwise, the effective date will be based on the rate of manufacture plus thirty (30) days.

Original Owner

Mailing Address

City State Zip Code

Daytime Telephone Number

Model Number

Serial Number

Date of Installation

Installation Site

Contractor/Installer

RAYPAK, INC • 2151 Eastman Avenue • Oxnard, CA 93030-9786 • (805) 278-5300 • Fax (800) 872-9725 • www.raypak.com

START-UP CHECKLIST FOR FAN-ASSISTED RAYPAK PRODUCTS - MVB

This start-up checklist is to be completely filled out by the service technician starting up the Raypak Boiler or Heater for the first time. All information may be used for warranty purposes and to ensure that the installation is correct. Additionally this form will be used to record all equipment operation functions and required settings.

GAS SUPPLY DATA

Regulator Model & Size _____ / _____ CFH
 Gas Line Size (in room) _____ In. NPT
 Length of Gas Line _____ Eq Ft
 Low Gas Pressure Setting _____ In. WC
 High Gas Pressure Setting _____ In. WC
 Gas Shut-Off Valve Type _____
 (Ball, Lube cock)
 Sediment Trap _____ Y/N
 Port _____ Std _____ Full

VISUAL INSPECTION OF COMPONENTS

Verify inspection was done and condition of components are in good working order with a "yes"

Wiring Harness _____ Y/N
 Burner/s (flame) _____ Y/N
 Refractory (visual) _____ Y/N
 Remote flame sense _____ Y/N
 Covers in place for outdoor _____ Y/N

VENTING

Vent Size: _____ Stack Height: _____
 Category: _____ sketch vent on reverse side ***
 Vent Material: _____
 Vent Termination Type: _____
 Combustion Air Openings: Low _____ in2
 Ventilation air High _____ in2

EMISSIONS SETTINGS AND TEST INFORMATION (AT FULL FIRE)

Blower Pressure Setting _____ In. WC
 Supply Gas Pressure _____ In. WC
 Verify stable pressure static & dynamic condition
 Pilot Gas Pressure _____ In. WC
 Manifold Gas Pressure _____ In. WC

The following measurements must be obtained with a Combustion Analyzer.

NOX _____ PPM	Less than 20 PPM (If required by Certifying Agency)
Free Oxygen _____ %	See manual
CO _____ PPM	Less than 150 PPM
CO2 _____ %	See manual

Model Number: _____

Serial Number: _____
 Site Altitude Above Sea Level _____ Ft.

*** Note: draw venting with details, such as extractors, barometric dampers, blast dampers or draft inducers

Job Name _____

Address _____

Physical Location of Boiler: Indoors _____; Outdoors _____; Ground Level _____; Roof _____; Below Grade _____

Mechanical Contractor / Installer _____

Date and Time of Start-up _____ Print Name and Signature of Start-up Technician _____

CLEARANCES

Front Clearance _____ In.
 Right Side Clearance _____ In.
 Left Side Clearance _____ In.
 Rear Clearance _____ In.
 Overhead Clearance _____ In.

ELECTRICAL

Voltage Supply (VAC) _____ No Load _____ Load _____
 Voltage -24 VAC _____ VAC
 Voltage Com to Ground _____ VAC
 Hot Surface Igniter _____ Ohms
 Auto High Limit Setting _____ deg F
 Manual Reset High Limit Setting _____ deg F
 Operating Control Setting _____ deg F

Sketch plumbing on reverse side

WATER SUPPLY

Flow Rate in GPM or Delta T _____ If Avail
Measure flow rate at full fire
 Pump Economaster setting _____ Minutes
 Low Water Cutoff _____ Test
 Number of Tanks and Size Qty _____ Gallons
 Plumbing Size _____
 Pump Size: _____ (boiler) Pump HP: _____
 Impeller trim _____ Pump Model _____
 Louvers _____ Screens _____

Nominal Factory Recommended Settings

See manual or card tag
 See manual or card tag
 See manual or card tag
 See manual or card tag

Information must be faxed to: (805) 278-5471 in order to ensure warranty consideration Attn: Service Manager



www.raypak.com

Raypak, Inc., 2151 Eastman Avenue, Oxnard, CA 93030 (805) 278-5300 Fax (805) 278-5468
Raypak Canada Limited, 2805 Slough St., Mississauga, Ontario, Canada L4T 1G2 (905) 677-7999 Fax (905) 677-8036
Litho in U.S.A.