

Job: _____

Engineer: _____

Contractor: _____

Prepared By: _____ Date: _____

Model: _____ Indoor/Outdoor: _____

Hi Delta[®] - Type H

Space Heating/Hot Water Boilers Models 302B-902B

MBTUH Input: _____

- ◆ 100% Factory Fire Tested
- ◆ Efficiency: 84%
- ◆ Maximum Outlet Temperature: 230°F
- ◆ Minimum Non-Condensing Inlet Temperature: 105°F
- ◆ Thermal Shock Proof Heat Exchanger
- ◆ Limited Twenty-Year Thermal Shock Warranty
- ◆ Limited Ten-Year Closed-System Heat Exchanger Warranty
- ◆ Diagnostic Center with Fault History
- ◆ PolyTuf Powder Coated Cabinet
- ◆ No Combustible Floor Shield Required
- ◆ Fan-Assisted
- ◆ Patented Burner Security Blanket

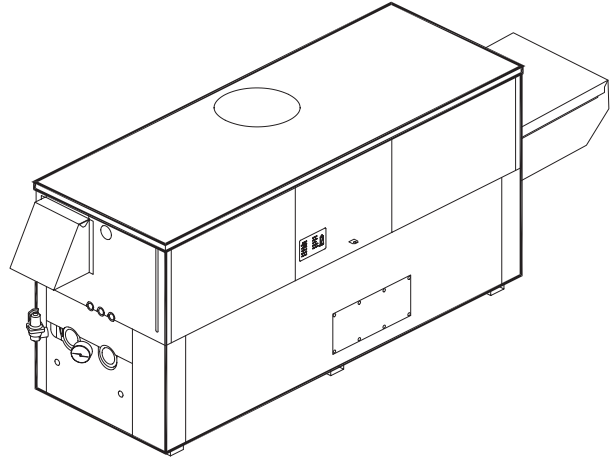

Heat Exchanger

- H Stamp
- Headers
 - Glass-Lined Cast Iron – Standard
 - Bronze – Option A-1
- ASME Inspected and Stamped
160 PSIG Working Pressure
- National Board Approved
- Fin Tubing
 - Copper – Standard
 - Cupro Nickel – Option A-3
- ASME Steel Tube Sheet
- Silicone High Temp. O-Rings
- ASME Pressure Relief Valve
 - 45 PSIG – Standard on Models 302B and 402B
 - 60 PSIG – Standard on Models 502B-902B
 - _____ PSIG – Optional
- Temperature and Pressure Gauge
- Water Connections
 - Left – Standard
 - Right – Option A-6

Controls

- 120V, 60Hz, 1Ø Power Supply
- 120/24V 60Hz Transformer
- 100% Shut-Off/Lockout
- Hot Surface Ignition
- Remote Flame Sensor
- High Limit Control, Manual Reset
- On/Off Power Switch
- Manual Shut-Off, Front-Mounted
- Flow Switch
- Blocked Vent Pressure Switch
- Combustion Air Proving Switch
- Economaster Pump Time Delay
- Enable/Disable

Gas Train

- Manual Gas Shut-Off Valve(s)
- Gas Pressure Regulator
- Safety Shut-Off Valve
- Firing Control Valve
- Firing Mode
 - On/Off (H4): Models 302B and 402B
 - 2-Stage (H3): Models 302B-902B
- Fuel
 - Natural Gas
 - Propane Gas
 - 4" WC Gas Supply Pressure G-20
- Design Certified ANSI Z21.13/CSA 4.9

Construction

- Indoor/Outdoor Construction
- Enclosed Front Controls

Venting

- Vent Location
 - Top – Standard
 - Rear – Option D-14
- Vent Termination Cap
 - Outdoor D-11
 - Indoor, Horizontal D-15
 - Indoor, Vertical (by others)
- Combustion Air
 - In-Line Filter Kit (TruSeal only) D-17
 - Air Intake Elbow D-16
- Extractor – Optional
 - By others
 - Not required

Burner

- Ultra-Low NOx: Less than 30 PPM

Temperature Controls

- B-2 Tankstat, Single-Stage (100-200°F)
- B-3 Tankstat, 2-Stage (100-200°F)
- B-6 Aquastat, 2-Stage (100-200°F)
- B-___ TempTracker Digital Controller, 2-Stage
- B-___ TempTracker Digital Controller, 4-Stage
- Y-241 Electronic Sequencer, 4-Stage
- Y-281 Electronic Sequencer, 8-Stage

Options

- C-6 Ignition Module, Manual Reset
- D-21 TruSeal[®] Direct Vent
- F-10 Low Water Cut-Off, Remote Probe
- I-1 High Limit Control, Auto Reset
- P-___ Pump: _____ HP, 120V, 1Ø, 60Hz
Water Hardness: _____ GPG
 - Cast Iron Bronze
 - Mounted Loose
 - Front Rear
- P-26 Cold Water Start (See 2000.48)
- S-1 Low Gas Pressure Switch, Manual
- S-2 High Gas Pressure Switch, Manual
- X-1 SureRack[™] Kit
- X-2 SureRack Add-on

Regulatory Agency Requirements



Raypak[®]
A Rheem[®] Company

Hi Delta – Type H Models 302B-902B

Model _____

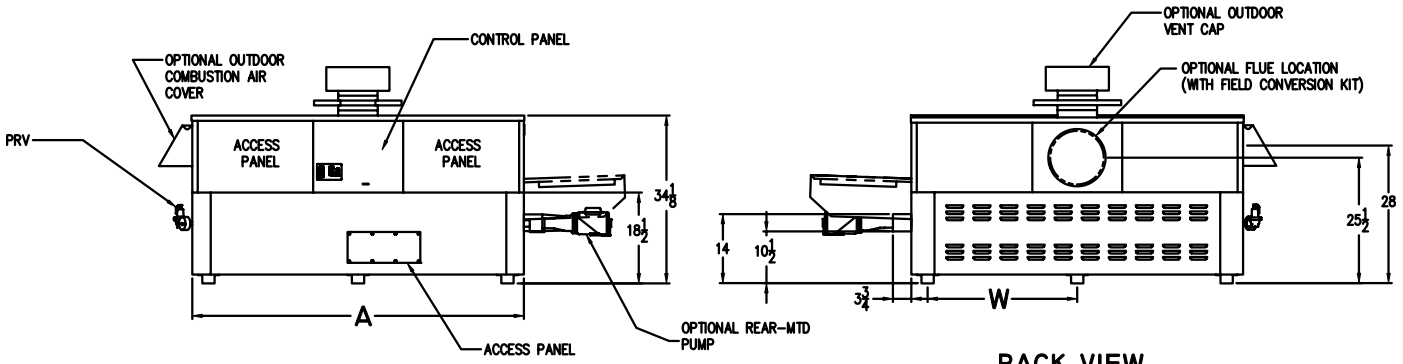

FRONT VIEW

BACK VIEW

NOTE: Pump location varies based on model and application

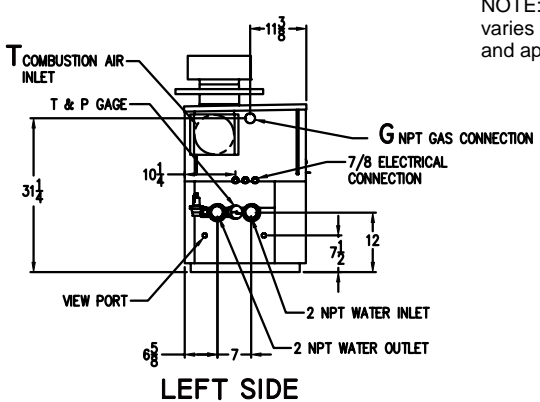

LEFT SIDE

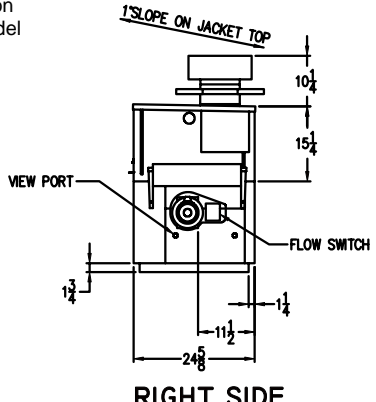

RIGHT SIDE

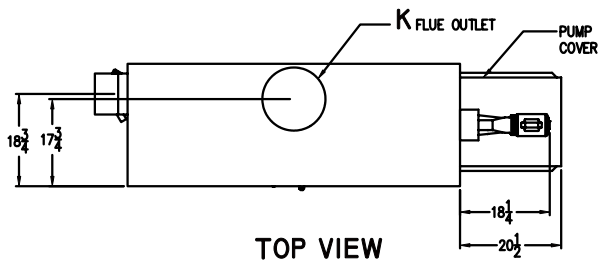

TOP VIEW

SPECIFICATIONS

Model	MBTUH		A Width	G NPT	H NPT	K	T	W	Amp. Draw	Approx. Shipping Wt. (Lbs)
	Input	Output								
302B	300	252	36	3/4	2	5	6	18	6	380
402B	399	335	43	3/4	2	6	6	18-1/2	6	445
502B	500	420	50	1-1/4	2	6	6	22	6	545
652B	650	546	60-1/2	1-1/4	2	8	6	27-1/4	6	590
752B	750	630	67-1/2	1-1/4	2	8	6	30-3/4	6	675
902B	900	756	78	1-1/4	2	8	6	36	7	740

Dimensions are in inches.

RATES OF FLOW AND PRESSURE DROPS

Model	10°F ΔT		20°F ΔT		30°F ΔT		Min. Flow			Max. Flow		
	GPM	ΔP (ft)	GPM	ΔP (ft)	GPM	ΔP (ft)	GPM	ΔP (ft)	ΔT	GPM	ΔP (ft)	ΔT
302B	51	3.2	25	<1.0	N/A	N/A	20	<1	25	90	9.8	6
402B	68	5.4	34	1.5	22	<1	20	<1	34	90	10.0	7
502B	85	9.2	42	2.3	28	1.1	21	<1	40	90	10.5	9
652B	N/A	N/A	55	4.0	36	1.8	28	1.1	40	90	10.7	12
752B	N/A	N/A	64	5.5	42	2.5	32	1.6	40	90	11.0	14
902B	N/A	N/A	76	8.5	51	3.8	38	2.2	40	90	11.8	17

Basis is 20 GPM or 40°F ΔT for minimum flow, 90 GPM for maximum flow.

NOTES: 1. Rates shown are for natural or propane gas, and elevations up to 5,000 feet. For installation above 5,000 feet, please contact manufacturer.
2. Required natural gas pressure is 7 – 10.5" WC. Required propane gas pressure is 11 - 13" WC.

Raypak, Inc. ▪ 2151 Eastman Avenue, Oxnard, CA 93030 ▪ (805) 278-5300 ▪ Fax (800) 872-9725 ▪ www.raypak.com