

Job: _____
 Engineer: _____
 Contractor: _____
 Prepared By: _____ Date: _____
 Model: _____

Raytherm® - Type H

Hydronic Heating Boilers
 Commercial

Models 962-1826 (Indoor)

EFFICIENT

- ▶ 82% efficiency – highest of any atmospheric boiler available today

THERMAL SHOCK PROOF

- ▶ Twenty-year warranty against thermal shock damage up to 150°F differential
- ▶ Maximum operating temperature: 230°F

LIGHTWEIGHT

- ▶ A floor load of 70 lbs./sq. ft. or less

HIGH RECOVERY

- ▶ Cuts fuel costs substantially because the standby and radiation losses normal to other boilers are eliminated

LOW WATER OPERATING TEMPERATURE

- ▶ Operates with inlet water temperature as low as 105°F without condensing

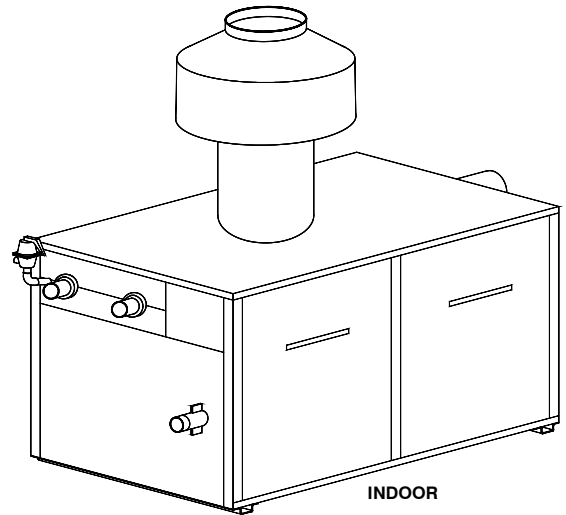

Heat Exchanger

- ASME Inspected and Stamped 160 PSIG
- National Board Listed
- Headers
 - Glass-lined Cast Iron – Standard
 - Bronze – Option A-1
- Finned Tubing
 - Copper – Standard
 - Cupro Nickel – Option A-3
- ASME Steel Tube Sheet
- Silicone O-Rings
- 60 PSIG ASME Pressure Relief Valve
- Temperature and Pressure Gauge
- Water Connections
 - Left Hand – Standard
 - Right Hand – Option A-6
- Flow Configuration
 - Two-pass – Standard
 - Single-pass – Cast Iron Only
- Pump - Rear-mounted, 1/2 HP, 120 VAC, 1Ø, 60 Hz – Optional
 - 4.25" Impeller
 - 4.7" Impeller

Controls

- 120V, 60Hz, 1 Ph Power Supply
- 120/24V Transformer
- 100% Pilot Shut-off/Lockout
- Electronic, Intermittent Ignition (IID) Pilot
- High Limit Control, Manual Reset, 240°F
- On/Off Switch

Controls (cont.)

- Flow Switch
- Economaster Pump Time Delay

Gas Train

- Manual Main Gas Shut-off Cock
- Main Gas Pressure Regulator
- Redundant Safety Shut-off Valve
- Control Valve
- Firing Mode
 - On/off (H4)
 - Two-stage Firing (H3)
 - Four-stage Firing (H9)
 - Mechanical Modulation, 110-170°F (H5)
 - Mechanical Modulation, 150-210°F (H1)
 - Motorized Modulation (H2)
- Fuel
 - Natural Gas
 - Propane Gas
- Design Certified ANSI Z21.13/CSA 4.9

Construction

- AB 1953 & VLA 193 Compliant
- Front Controls
- Stainless Steel Burners
- Polytuf Powder Coat Finish
- Vent Selection
 - Draft Diverter – Option D-10
 - Power Vent, Loose – Option D-2
- Base (Optional)
 - Combustible Floor Shield – Option J-1

Temperature Controllers

Note: H1 and H5 do not require a controller

- B-6 Two-stage
- B-36 TempTracker Mod+ Hybrid
- B-40 Motorized Modulation
- B-41 Motorized Modulation, Outdoor Reset
- B-___ Four-stage Digital
- Y-241 Electronic Sequencer, 1-4 Stages
- Y-281 Electronic Sequencer, 1-8 Stages
- _____ Remote Controller
 - By others:

Additional Safety Controls

- F-9 Low Water Cut-off Probe
- I-1 High Limit Control, Auto Reset, 240°F
- S-1 Low Gas Pressure Switch, Manual
- S-2 High Gas Pressure Switch, Manual
- _____
- _____

Regulatory Agency Requirements

- _____
- _____



Raypak®
 A Rheem® Company

Raytherm - Type H Hydronic Heating Boilers

Model _____

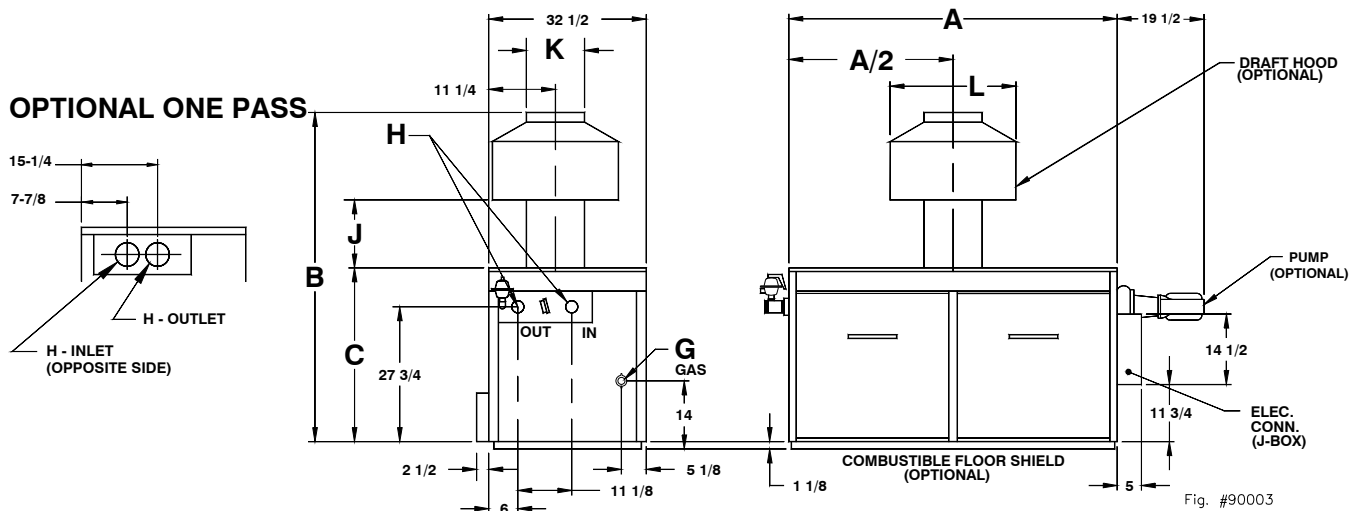

Fig. #90003

MODELS 962 THRU 1826

Model Size	MBTUH Natural Gas		Dimensions (Inches)								Approx. Shipping Weight (Lbs.)
	Input	Output	Width A	Overall Height B	Jacket Height C	Gas Conn. G	Water Conns. H	J	Flue Dia. K	L	
H-962	961.7	788.6	52-3/8	76-1/8 (a)	33-1/2	1	2-1/2 (c)	23-5/8	14	28	705
H-1125	1124.7	922.0	59-1/4	78-1/8 (a)	33-1/2	1 (b)	2-1/2 (c)	23-5/8	16	32	745
H-1223	1222.5	1002.4	63-5/8	78-1/8 (a)	33-1/2	1 (b)	2-1/2 (c)	23-5/8	16	32	805
H-1336	1336.6	1096.0	68-5/8	80-1/8 (a)	33-1/2	1-1/4	2-1/2 (c)	23-5/8	18	36	875
H-1468	1467.0	1203.0	74-7/8	80-1/8 (a)	33-1/2	1-1/4	2-1/2 (c)	23-5/8	18	36	945
H-1631	1630.0	1336.6	81-1/8	83-1/8 (a)	36-1/2	1-1/4	2-1/2 (c)	23-5/8	18	36	985
H-1826	1825.6	1497.0	89-3/8	85-1/8 (a)	36-1/2	1-1/4	2-1/2 (c)	23-5/8	20	40	1035

NOTE: Ratings shown are for elevations up to 2,000 feet. For elevations over 2,000, reduce ratings at the rate of 4% for each 1,000 feet above sea level.

- (a) Add 1-1/8" to overall height for combustibile floor shield option
- (b) 1" or 1-1/4" contingent on boiler type or code requirements
- (c) 3" NPT on single-pass option
- (d) Propane input/output is 92% of standard values

BOILER RATE OF FLOW AND PRESSURE DROP

Model No.	10° ΔT		20° ΔT		30° ΔT		40° ΔT		Minimum Flow			Maximum Flow				
	GPM	ΔP FT	GPM	ΔP FT	GPM	ΔP FT	GPM	ΔP FT	GPM	ΔP FT	ΔT	GPM	ΔP FT	ΔT		
TWO-PASS	H-962	Exceeds Maximum Flow	80	8.8	53	3.8	40	2.2	40	2.2	38	90	11.0	18		
	H-1125		90	12.0	61	5.5	47	3.3	45	3.1	40	90	12.0	21		
	H-1223		76	7.0	51	4.0	51	4.0	51	4.0	40	90	12.5	22		
	H-1336		73	8.6	55	4.9	55	4.9	55	4.9	40	90	13.2	25		
	H-1468		80	11.0	61	6.4	61	6.4	61	6.4	40	90	14.0	27		
	H-1631		90	14.8	68	8.3	68	8.3	68	8.3	40	90	8.3	30		
	H-1826		76	10.8	76	10.8	76	10.8	76	10.8	40	90	15.4	34		
ONE-PASS	H-962	157	6.1	Less than Minimum Flow	90	2.1	18	200	9.7	8						
	H-1125	184	8.8								90	2.3	200	10.3	9	
	H-1223	200	11.0								90	2.4	22	200	11.0	10
	H-1336	110	3.7								90	2.5	24	200	11.7	11
	H-1468	120	4.5								90	2.7	27	200	12.2	12
	H-1631	134	6.0								90	2.8	30	200	13.0	13
	H-1826	150	8.0								100	3.7	90	3.0	33	200

NOTES:

- Values represent maximum flows and pressure drops for closed heating systems
- Maximum acceptable flow through heat exchanger tubes is 90 GPM (two-pass); 200 GPM (one-pass)
- Single-pass heat exchangers are to be used only when flow rates exceed the allowable for two-pass

Raypak, Inc. ▪ 2151 Eastman Avenue, Oxnard, CA 93030 ▪ (805) 278-5300 ▪ Fax (800) 872-9725 ▪ www.raypak.com