



# **Manual for MD8520P1 & MD8530P1**

## 1. Description

Raytac's MD85XXP1 audio module is a cost-effective and low-power solution optimized for wireless transmission of high-quality digital audio. We use TI's CC8520/CC8530 IC (Digital I2S I/O) and CC8521/CC8531 (USB full speed I/O) IC which includes a robust built-in wireless audio transmission protocol and can control selected external audio devices.

The wireless range is up to 100 meters line of sight with an external PA (TI CC2590). Utilizing numerous coexistence mechanisms allows MD85XXP1 to avoid interfering with, or being interfered by other 2.4GHz radio systems. Therefore, MD85XXP1 has excellent anti-WiFi performance. MD85XXP1 operates autonomously, and can be used with or without an external MCU. An external host processor can be connected through SPI and control some aspects of its operation.

Combined with the easy-to-use configuration tool and application reference designs, MD85XXP1 wireless audio module ensures flexibility, cost-efficiency and a fast time-to-market.

## 2. Features

- Solution : TI CC8520/CC8530(Digital I2S I/O); TI CC8521/CC8531(USB 1.1 I/O)
- Wireless range up to 100 meters line of sight with an external PA (TI CC2590)
- Excellent Anti-WiFi Performance
- Uncompressed stereo CD audio quality
- Can be used autonomously, or being controlled by an external host MCU
- Seamless connection and control of selected TI audio codecs, DACs/ADCs
- Model No.: MD8520P1/ MD8521P1/ MD8530P1/ MD8531P1
- Frequency Range: 2.4GHz – 2.483GHz
- Solution: TI CC8520/CC8530 (Digital I2S I/O); TI CC8521/CC8531 (USB full speed I/O)
- RF Channel No.: up to 18 channels
- Modulation: 8GFSK (frequency hopping)
- Data Rate: up to 5Mbps
- Distance: up to 100 meters line of sight
- Audio Channel No.: 2 for MD8520/MD8521P1; 3 or 4 for MD8530P1/MD8531P1
- Software or Drivers: 2.0V ~ 3.6V
- Operating Temperature: -40 ~ +85
- Audio Sample Rate: up to 48kHz / 16bits (Uncompressed)

- Transmitter Output Power: 11dBm
- Receiver Sensitivity: -87dBm
- Dimension (L x W): 34 x 14.7mm

### 3. Applications

- Wireless speakers.
- Home theater rear speakers.
- Wireless audio sender for CD / DVD player.
- USB and PC wireless audio
- TV/Set-top box wireless audio
- Music instrument

### 4. Block Diagram

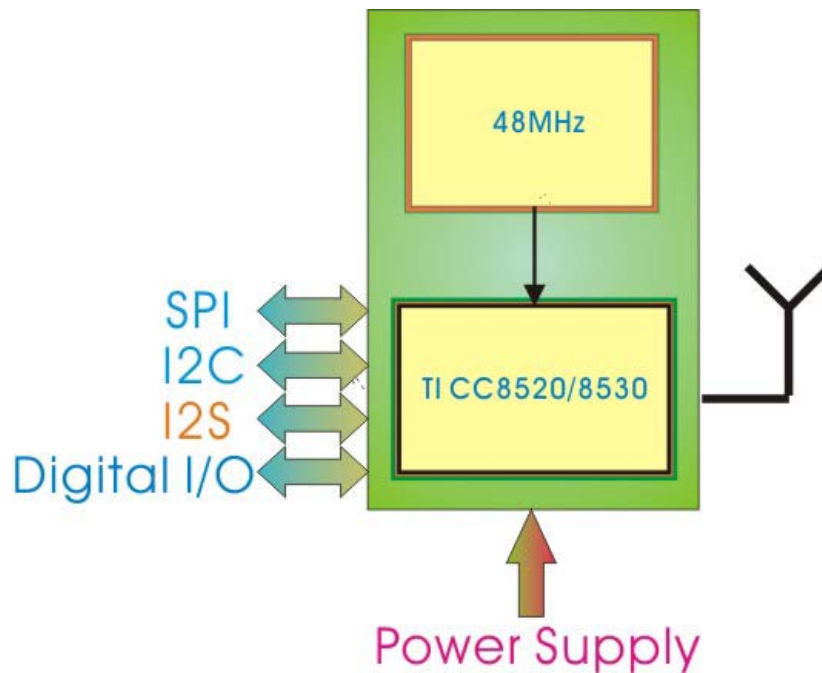

**Note: I2C must be connected to external pull-up resistor 2.7K . VBAT has internal resistor 100K on Module.**

# 5. Pin Assignment & Definition

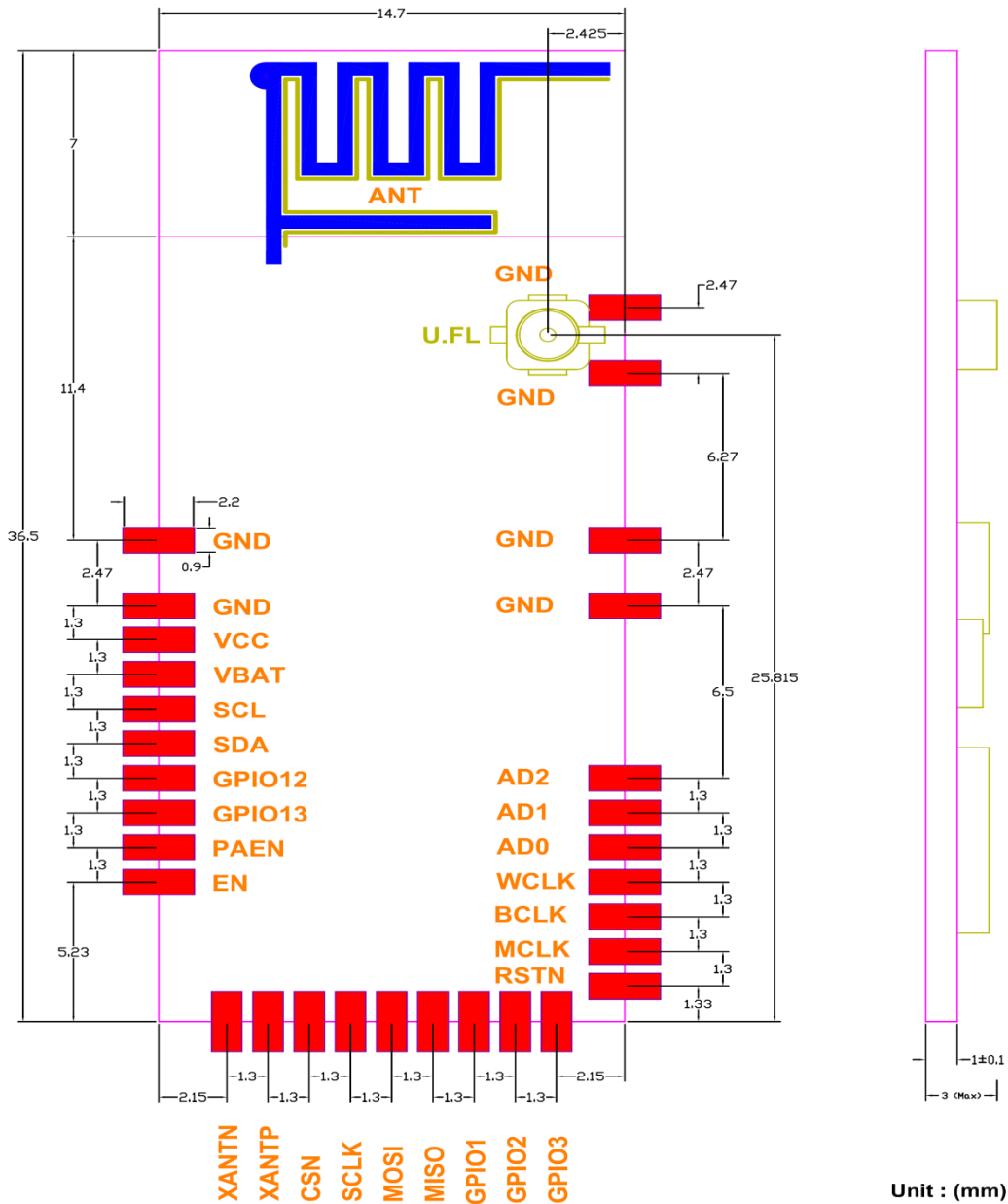

PCB Material Properties and plating	
Product Name	FR-4 COPPER CLAD LAMINATE / PREPREG SM700,SM730,SM750,SM630,SM560)
Manufacturer	ShineMore Technology Materials Co.
Flammability	UL94V-0
Plating	Gold ( Thickness 2.0 micro m)

## Pin Assignment

Name	Pin function	Description
<b>GND</b>	Ground	The exposed die attach pad must be connected to a solid ground plane underneath the chip
<b>VCC</b>	Power	2.0-3.6V analog power supply connection
<b>VBAT</b>	Analog input	Battery voltage supervisor (threshold level programmable by external resistor to positive battery terminal)
<b>SCL</b> <b>GIO10</b>	Digital I/O <sup>1</sup>	I2C master clock line. Must be connected to external pull-up General-purpose digital I/O pin 10
<b>SDA</b> <b>GIO11</b>	Digital I/O <sup>1</sup>	I2C master clock line. Must be connected to external pull-up General-purpose digital I/O pin 11
<b>GIO12</b>	Digital I/O <sup>1</sup>	General-purpose digital I/O pin 12
<b>GIO13</b>	Digital I/O <sup>1</sup>	General-purpose digital I/O pin 13
<b>PAEN</b>	Digital I/O <sup>2</sup>	Control external PA
<b>EN</b>	Digital I/O <sup>2</sup>	Control external LNA
<b>XANTN</b> <b>USBN</b>	Digital I/O <sup>1</sup>	CC85x0: DO NOT CONNECT (Future FW: Controlling external antenna switch) CC85x1: USB D- data line
<b>XANTP</b> <b>USBP</b>	Digital I/O <sup>1</sup>	CC85x0: DO NOT CONNECT (Future FW: Controlling external antenna switch) CC85x1: USB D+ data line
<b>CSN</b>	Digital Input (pull-up)	Serial SPI configuration interface, active low chip select
<b>SCLK</b>	Digital I/O <sup>1</sup>	Serial SPI configuration interface, clock input/output
<b>MOSI</b>	Digital I/O <sup>1</sup>	Serial SPI configuration interface, master data output, slave data input
<b>MISO</b>	Digital I/O <sup>1</sup>	Serial SPI configuration interface, master data input, slave data output
<b>GIO1</b>	Digital I/O <sup>1</sup>	General-purpose digital I/O pin 1 Configurable with PurePath™ Wireless Configurator
<b>GIO2</b>	Digital I/O <sup>1</sup>	General-purpose digital I/O pin 2
<b>GIO3</b>	Digital I/O <sup>2</sup>	General-purpose digital I/O pin 3 Configurable with PurePath™ Wireless Configurator
<b>RSTN</b>	Digital Input (pull-up)	Active-low device reset
<b>MCLK</b> <b>GIO4</b>	Digital I/O <sup>1</sup>	Master clock output for external audio devices General-purpose digital I/O pin 4
<b>BCLK</b> <b>GIO5</b>	Digital I/O <sup>1</sup>	I2S/DSP audio interface bit clock (in/out) General-purpose digital I/O pin 5

Name	Pin function	Description
<b>WCLK GIO6</b>	Digital I/O <sup>1</sup>	I2S/DSP audio interface word clock (in/out) General-purpose digital I/O pin 6
<b>AD0 GIO7</b>	Digital I/O <sup>1</sup>	I2S/DSP audio interface data line 0 (in/out) General-purpose digital I/O pin 7
<b>AD1 GIO8</b>	Digital I/O <sup>1</sup>	I2S/DSP audio interface data line 1 (in/out) General-purpose digital I/O pin 8
<b>AD2 GIO9</b>	Digital I/O <sup>2</sup>	I2S/DSP audio interface data line 2 (in/out) Configurable with PurePath™ Wireless Configurator

<sup>1</sup> Digital I/O pad with 4 mA source/sink capability.

<sup>2</sup> Digital I/O pad with 20 mA source/sink capability.

## 6. Regulatory Notices:

### **Federal Communication Commission Interference Statement:**

This device complies with part 15 of the FCC rules. Operation is subject to the following two conditions

- (1) This device may not cause harmful interference and
- (2) This device must accept any interference received, including interference that may cause undesired operation

This equipment has been tested and found to comply with the limits for a Class B digital device, pursuant to Part 15 of the FCC Rules. These limits are designed to provide reasonable protection against harmful interference in a residential installation. This equipment generates, uses and can radiate radio frequency energy and, if not installed and used in accordance with the instructions, may cause harmful interference to radio communications. However, there is no guarantee that interference will not occur in a particular installation. If this equipment does cause harmful interference to radio or television reception, which can be determined by turning the equipment off and on, the user is encouraged to try to correct the interference by one of the following measures:

- Reorient or relocate the receiving antenna.
- Increase the separation between the equipment and receiver.
- Connect the equipment into an outlet on a circuit different from that to which the receiver is connected.
- Consult the dealer or an experienced radio/TV technician for help.

**FCC Caution:** To assure continued compliance, any changes or modifications not expressly approved by the party responsible for compliance could void the user's authority to operate this equipment. (Example - use only shielded interface cables when connecting to computer or peripheral devices).

**IMPORTANT NOTE: FCC Radiation Exposure Statement:**

To comply with FCC RF exposure compliance requirements, the antenna used for this transmitter must be installed to provide a separation distance of at least 20 centimeter from all persons and must not be co-located or operating in conjunction with any other antenna or transmitter.”

**End Product Labeling**

This transmitter module is authorized only for use in devices where the antenna may be installed such that 20 centimeter may be maintained between the antenna and users. The final end product must be labeled in visible area with the following: “Contains FCC ID: SH6MD85XXP1”

**This device is intended only for OEM integrators under the following conditions:**

The MD85XXP1 may transmit simultaneously with other collocated radio transmitters within a host device, provided the following conditions are met:

1. Each collocated radio transmitter has been certified by FCC for mobile application.
2. At least 20 cm separation distance between the antennas of the collocated transmitters and the user’s body must be maintained at all times.

As long as 2 conditions above are met, further transmitter test will not be required. However, the OEM integrator is still responsible for testing their end-product for any additional compliance requirements required with this module installed.

**IMPORTANT NOTE:** In the event that these conditions cannot be met (for example co-location with another transmitter), then the FCC authorization is no longer considered valid and the FCC ID cannot be used on the final product. In these circumstances, the OEM integrator will be responsible for reevaluating the end product (including the transmitter) and obtaining a separate FCC authorization. As long as a condition above is met, further transmitter test will not be required. However, the OEM integrator is still responsible for testing their end product for any additional compliance requirements required with this module installed (for example, digital device emissions, PC peripheral requirements, etc.)

**Manual Information to the End user**

The OEM integrator has to be aware not to provide information to the end user regarding how to install or remove this RF module in the user’s manual of the end product which integrates this module.

The end user manual shall include all required regulatory information/warning as show in this manual.

**Antenna Restriction**

The antenna is designed as permanent attached and no consideration of replacement.