

Collage

IN2UIT

Audio Art : Bluetooth Acoustic Device

IMPORTANT SAFETY INSTRUCTIONS

1. Read these instructions carefully.
2. Heed all warnings.
3. Install in accordance with the manufacturer's instructions.
4. Only use attachments/accessories specified by the manufacturer.
5. Clean only with a dry cloth.
6. Do not use or place this apparatus near water.
7. Do not install near any heat sources such as radiators, stoves, or other apparatus (including amplifiers) that radiate heat.
8. Protect the power cord from being trampled on, pinched or twisted at the plug & tail ends.
9. Unplug this apparatus during lightning storms or when unused for long periods of time.
10. Refer all servicing to qualified service personnel.
11. Servicing is required when the device has been damaged in any way.

WARNING

- To reduce the risk of fire or electrical shock, do not expose this equipment to dripping or splashing and ensure that no objects with liquids, such as vases, are placed near the device.
- Be advised that different operating voltages and power sockets require matching adaptors and plugs for your particular region.
- Always observe the local safety regulations.
- This device should be installed near the power outlet and disconnection of the device should be easily accessible.
- To completely power off the device, disconnect the power supply cord from the AC outlet.
- Do not place the device in a confined space with limited ventilation or blockage.
- Do not open, disassemble or tamper with the device as there is a serious risk of electric shock.

SERVICE

- There are no user-serviceable parts.
- All service must be performed by qualified personnel

CAUTION

- Users are advised that any tampering or modifications to the device that have not expressly stated in this manual could void your warranty

FCC Statement:

Federal Communication Commission Interference Statement

This equipment has been tested and found to comply with the limits for a Class B digital device, pursuant to Part 15 of the FCC Rules. These limits are designed to provide reasonable protection against harmful interference in a residential installation. This equipment generates, uses and can radiate radio frequency energy and, if not installed and used in accordance with the instructions, may cause harmful interference to radio communications. However, there is no guarantee that interference will not occur in a particular installation. If this equipment does cause harmful interference to radio or television reception, which can be determined by turning the equipment off and on, the user is encouraged to try to correct the interference by one of the following measures:

- Reorient or relocate the receiving antenna.
- Increase the separation between the equipment and receiver.
- Connect the equipment into an outlet on a circuit different from that to which the receiver is connected.
- Consult the dealer or an experienced radio/TV technician for help.

FCC Caution: Any changes or modifications not expressly approved by the party responsible for compliance could void the user's authority to operate this equipment.

This device complies with Part 15 of the FCC Rules. Operation is subject to the following two conditions: (1) This device may not cause harmful interference, and (2) this device must accept any interference received, including interference that may cause undesired operation.

CONTENTS

INTRODUCTION	1
PACKAGE CONTENTS	1
OVERVIEW	2
Front view	2
Rear panel	3
PLACING THE SPEAKER	4
Placing on your desktop	4
Mounting your speakers on a wall	5
OPERATING	6
Connecting the AC power	6
Control button	6
Audio input through Bluetooth wireless connection	6
Audio input from 3.5mm stereo jack	7
System status indicator table	7
Optimization of audio performance	8
TROUBLESHOOTING	8
CARE AND MAINTENANCE	9
CONTACTING CUSTOMER SERVICE	10
WARRANTY	10
TECHNICAL SPECIFICATIONS	11
APPENDIX	11

INTRODUCTION

Dear Audiophile,

Thank you for purchasing 'Collage' by IN2UIT. Collage features hi-end tweeters using the proprietary SBESL (Self-Biased ElectroStatic Loudspeaker) acoustic technology that we refer to as **ELECTROSTATZ™**. The acoustic performance and reproduction are of the highest quality and level, revitalizing your many familiar sounding recordings into a new listening experience.

This advanced proprietary technology results from years of intense research and development. IN2UIT along with our US-based acoustic technology partner ENIGMAcoustics are one of the very few companies who have accessed, commercialized and realized this technology for the masses in designer styling. Each **ELECTROSTATZ™** tweeter is constructed in state-of-the-art facilities using proprietary manufacturing techniques and equipment, cohering to rigorous standards and manufacturing processes. To reproduce the ultimate sound quality output from our devices, certain user requirements have been addressed in this owner's manual. By conforming to our tips and suggestions, you will achieve the maximum performance from the device. We wish you many years of enjoyment through Collage, our ultra-high performance Bluetooth speaker.

PACKAGE CONTENTS

- 1 x Collage - Bluetooth speaker device.
- 1 x 15V / 4A DC power adaptor
- 1 x stand
- 8 x rubber base
- 2 x screws
- 1 x warranty card

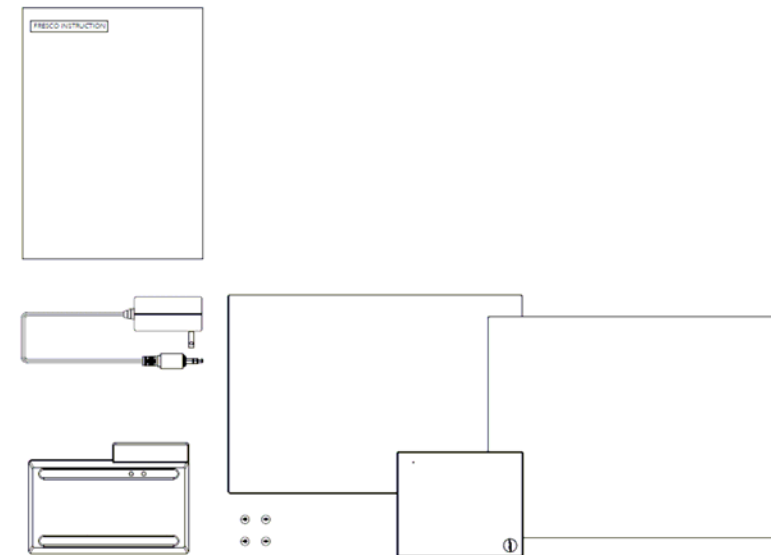

OVERVIEW

Front view

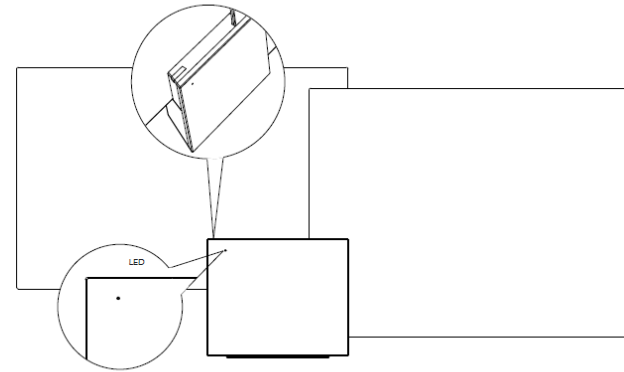
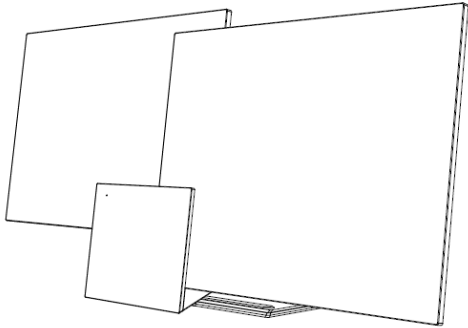

-
1. Power / Bluetooth pairing button (Right inset picture)
 2. Power / Bluetooth LED indicator (Left inset picture)
 3. SBESL **ELECTROSTATZ**TM tweeters (LHS / RHS stereo sound)

Rear panel

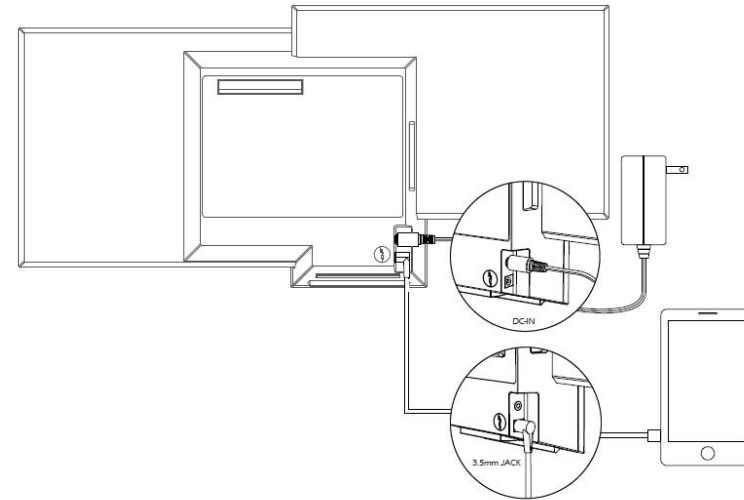
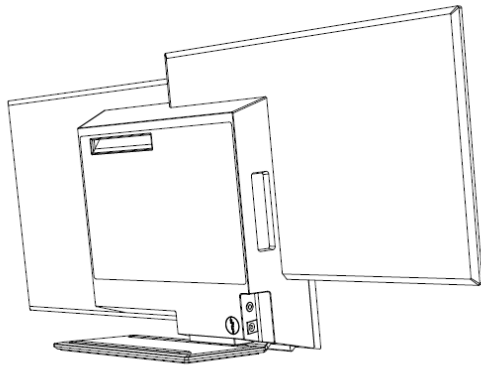

-
1. 3.5mm stereo input jack (Top inset picture)
 2. DC-in socket (Bottom inset picture)
 3. SBESL **ELECTROSTATZ™** tweeters

PLACING THE SPEAKER

Placing on your desktop

1. For desktop usage, embedding operation is simple (see the picture inset), just align the stand protrusion with the rectangle stand receptacle in the bottom of the unit. Make sure it is seated and engaged properly.
2. There are two screw holes of the bottom of the stand. They should automatically align the screw holes of the bottom of the unit.
3. Secure the stand to the unit using the screws (x2) provided
4. Stick the rubber base (x8) provided in the groove of the stand.
5. Now you can place the Collage on your desktop. Just make sure placing the speaker on a firm, level surface. Do not lay the speaker on its back during playback.
6. For best bass response, the speaker should be placed near a wall.
7. To avoid adverse sound quality, do not place the speaker in confined areas that are enclosed or block the sound wave dynamics.

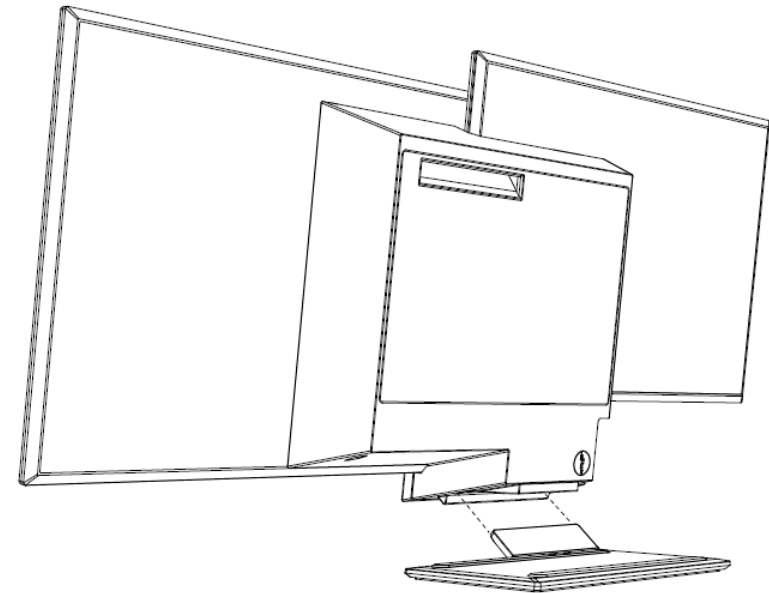

Mounting your speakers on a wall

NOTICE: Do not mount the speaker on surfaces that are not sturdy enough, or have hazards, such as electrical wire or plumbing, concealed behind them. If you are unsure about installing the speaker, contact a qualified professional. The brackets were specifically designed to support the weight of 'Collage' only.

1. Place the wall-mounting bracket of the Collage speaker in the desired location against the wall and mark the screw locations (x2) with a pencil, using the bracket as a template. Use a tape measure to measure the height from the floor to the marked holes and make sure they are level and equidistant. If you plan to feed wires through the wall, mark the pilot hole position first.
2. Choose the screws to fit the hole of the wall-mounting bracket, however if your wall surface is hard, like concrete, drill pilot holes to insert anchor plugs for the screws to engage with. Remember always measure twice
3. Secure the screws (x2) on the wall.
4. Mounting operation is simple (see the picture inset), just hanging the wall-mounting bracket of the Collage speaker on the screws. The speaker now is ready to use.

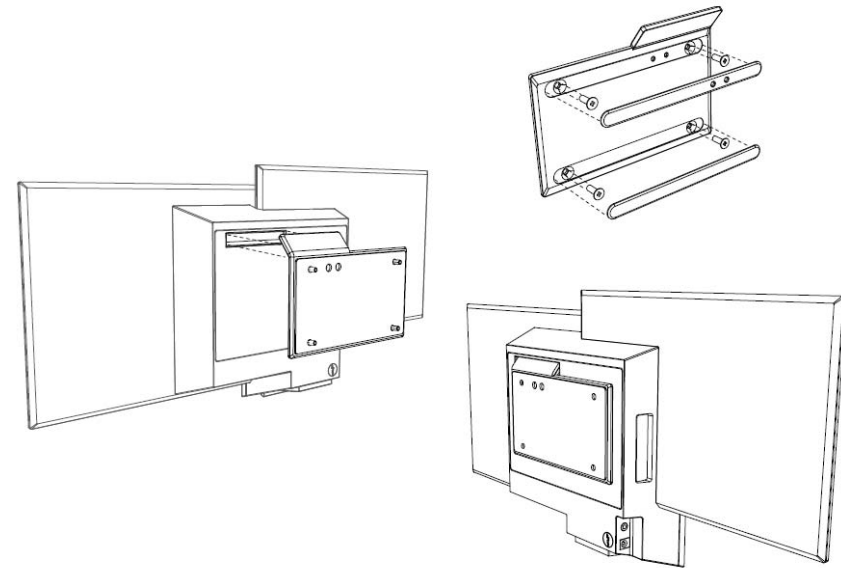

NOTICE: The **ELECTROSTATZ™** tweeter panels, LHS & RHS, are dipole i.e. sound waves travel in both directions. To maintain the highest quality acoustic performance, never block the rear sound output area and always maintain at least a 3cm distance between the tweeter panels and the wall. The mounting bracket will automatically provided the clearance required

OPERATING

NOTICE: For safety purposes always turn off the main power switch when plugging or unplugging in the device.

Connecting the AC power

The universal power adaptor that comes with Collage accepts multiple voltages (100-240V); however users are advised to check regional AC voltage supply and plug type before connecting to the power supply. Prior to connecting to the power supply, make sure the speakers are switched off first. Engage the male DC-in plug and female DC-in receptacle on the rear of the device. Turn on the speakers' power as indicated below.

Control button

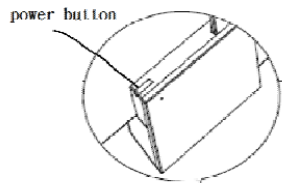

- Press to turn the speaker on and off
- Press to pair Bluetooth device

Action	Power On	Power On + Pairing	Re- Pairing (after power is on)	Power Off
Pressing Time	1 ~ 2 seconds	2 seconds	2 seconds	Less than 1 second

Audio input through Bluetooth wireless connection

To begin pairing with a Bluetooth device

1. If the device is already turned on, press and hold the power button on the speaker for two seconds to pair both devices
2. If device power is off, press and hold the power button on the speaker for two seconds to both turn on and pair the speaker.
3. Enable the Bluetooth function on your music players (Apple, Android, MP3 etc.) and start the Bluetooth search for the device named as "IN2UIT Collage".
4. Choose and confirm the connection to "IN2UIT Collage" from your music player.
5. After successful connection, you are ready to play music from your player. Adjust the required volume on your music player for comfortable and non distorted playback. Maximum volume output may cause clipping on some type of music.

NOTICE: Pairing occurs when the two Bluetooth devices communicate with each other and establish a connection. A record of information about this connection is then stored in the memory of each device. Once you pair a device with the Collage speaker, you should not have to pair it again.

NOTICE: You may have to enter the password "0000" in order to connect Bluetooth device.

NOTICE: Collage support Bluetooth 2.1 with **apt-X** , but the device connected to Collage must support Bluetooth **apt-X** to enable Bluetooth **apt-X**.

Audio input from 3.5mm stereo jack

You can connect an audio devices without Bluetooth™ function, such as a portable digital MP3 player, with Collage. This requires using an audio cable with a 3.5 mm stereo plug to connect with the 3.5mm jack input on the Collage system. A stereo audio cable with 3.5mm stereo male plugs on both ends is required (not included in the package).

1. Make sure the speakers are switched off.
2. Connect the 3.5mm plug to audio source (e.g. MP3 player)
3. Connect the other 3.5mm plug end to Collage
4. Disconnect any Bluetooth connections
5. Play music from a player connected via the 3.5mm stereo cable.

NOTICE: Using higher quality cables will improve the sound quality and help Collage speakers realize their full potential.

NOTICE: the device connected to Collage must have volume control.

NOTICE: Automatic Power shutdown. If there is no Bluetooth connection or Line-in connection for over 10 minutes, the system shall automatically shutdown. User needs to power on the system for usage after automatic shutdown.

System status indicator table

LED Indication table

Table 1 status indication

	Status		
LEDs	BT Connected	Pairing	Not paired
Blue	On	Flash(0.5s)	On
Orange	Off	Flash(0.5s)	On

Beep indication table

	Status				
Tones	Power On	Power Off	Connected	Disconnected	Low battery
High	3rd	1st	1st		
Mid	2nd	2nd			
Low	1st	3rd		1st	1 st +2 nd
Actions	Low to high (triple)	High to low (triple)	High (once)	Low (once)	“Du” twice every 20 seconds

Optimization of audio performance

IN2UIT systems feature proprietary, leading edge Electrostatic Loudspeaker (ESL) technology that we call our **ELECTROSTATZ™** tweeter technology. The ethereal acoustic characteristics provide the user with the highest class of audio playback. In order to maximize this performance, it is advised to read the following instructions:

1. **ELECTROSTATZ™** tweeters are dipole transducers. This means the sound waves are transmitted from both sides of the diaphragm in opposite polarity. A dipole transducer produces one sound wave to the front and another sound wave to the rear.
2. When mounted on the wall brackets, the distance and clearance from the **ELECTROSTATZ™** back plane to the wall is optimal. In other possible placement criteria, users are advised to keep a clearance of at least 3cm from any object that may cause blockage of the front and rear sound waves. A blockage less than 3cm to the rear of ESL speakers may result in the loss of sound pressure and less volume output.
3. When correctly positioned, for example, closer to the wall, the reflected ESL back sound wave can be amplified and help create a wider, deeper sound stage for more realistic acoustic performance. The result is life-like music reproduction previously unachieved in the market place of comparably sized audio systems.

TROUBLESHOOTING

Problem	Action
Speaker will not turn on (AC power)	<ul style="list-style-type: none"> • Make sure your system is connected to a working AC (mains) outlet.
Speaker will not turn on (battery power)	<ul style="list-style-type: none"> • Battery may be discharged – connect to working AC (mains) outlet to restore the battery to operational mode.
Paired Bluetooth device will not connect	<ul style="list-style-type: none"> • Turn the Collage speaker off and back on. • Remove the Collage speaker from the pairing list on your Bluetooth device pairing list (consult the device owner's manual for assistance). Then pair the device and the Collage speaker again.
Collage speaker indicates a connection, but is not playing music	<ul style="list-style-type: none"> • Turn off or disable Bluetooth on all other paired devices in the vicinity. Reconnect the device you want to listen to. • Turn the Collage speaker off and back on again.
Cannot pair the Collage speaker with my Bluetooth device	<ul style="list-style-type: none"> • Make sure your Collage speaker is discoverable. Press and hold the power button (three seconds) until the LEDs slowly flash. • Make sure the Bluetooth capability of your Bluetooth device is turned on. • Your Bluetooth device may be out of range – try moving it closer to the Collage speaker. • Make sure your Bluetooth device supports the transfer of audio. • Move your Bluetooth device and/or Collage speaker away from other devices that generate electromagnetic interference. Examples are cordless phones, microwave ovens, wireless network routers, or other Bluetooth devices. • If possible, turn off all other nearby Bluetooth devices. • Turn the Collage speaker off and back on. • Refer to the owner's guide, help system, or technical support for your device to learn how it pairs with other Bluetooth devices.

No audio from a Bluetooth device	<ul style="list-style-type: none"> • Make sure your Bluetooth device is playing audio, and the volume is up. • Your Bluetooth device may be out of range – try moving it closer to the Collage speaker. • Turn the Collage speaker off and back on again.
Poor sound quality from a Bluetooth device	<ul style="list-style-type: none"> • Your Bluetooth device may be out of range – try moving it closer to the Collage speaker. • Move your Bluetooth device and/or Collage speaker away from any device that generates electromagnetic interference, such as another Bluetooth device, cordless phone, microwave oven, or wireless router. • Reduce the number of applications running on your Bluetooth device. Running multiple applications can reduce the amount of internal resources available to transmit audio. Closing non-essential applications may improve audio quality. • Try turning off Wi-Fi to improve audio quality. • Try un-pairing your Bluetooth device from the Collage speaker and then re-pairing the two. This action can possibly clear issues that might have occurred during initial device pairing. • Turn the Collage speaker off and back on

Problem	Action
No audio from the 3.5mm jack source	<ul style="list-style-type: none"> • Make sure your connected device is on and playing. • Make sure the 3.5 mm plug is fully inserted into the Collage speaker. • Increase the volume level on the device.
Poor sound quality from the 3.5mm jack source	<ul style="list-style-type: none"> • Reduce the volume level on the 3.5mm jack source. • Make sure the 3.5 mm plug is fully inserted into the Collage speaker

CARE AND MAINTENANCE

Components of the highest quality are used in **Collage**. This assures years of trouble free operation. The following precautions should still be strictly adhered to.

Cleaning

Use a specialized cleaning brush or vacuum cleaner (low setting) with nozzle attachment to clean speaker cloth and device. If you wish to use a cleaning agent, apply it onto the cleaning cloth, not directly onto the product. Test a small area first, as some cleaning products may damage the surfaces and materials. Avoid products that are abrasive, contain acid, alkali or anti-bacterial agents.

Recycling used products



This product is subjected to the European Union Waste Electrical and Electronic Equipment directive (WEEE), 2002/96/EC. This product must not be disposed of as unsorted municipal waste and must be collected separately and disposed according to your national regulations.

CONTACTING CUSTOMER SERVICE

For questions concerning the Collage wireless speaker, contact your local IN2UIT dealer. To contact IN2UIT directly, consult the contact information included with your Collage speaker or visit **www.IN2UIT.com**

WARRANTY

- The warranty only covers faults or defects in material and production. Damage caused as a result of abuse, misuse or tampering is not covered by the warranty.
- All warranty claims must be accompanied by a copy of the original filled out warranty document and certified by your dealer.
- Purchasing invoice and warranties are only valid in the country or market of original origin and distribution. Should warranty service be required, it must be arranged for in the country of purchase by an authorized dealer.

TECHNICAL SPECIFICATIONS

System	Two-way active speaker Bluetooth speaker with apt-X
Frequency Response (+/- 3 dB)	100Hz – 30kHz
Amplifier power	Tweeter: 2.5+2.5W / Woofer: 10W+10W
Tweeter	ELECTROSTATZ™ ESL x 2
Woofer	2 x 2"
Weight (kg)	1.2
Dimensions (W x H x D) (mm)	530 X 260 X 60
Bluetooth Specification	Version 2.1 + EDR
Supported Bluetooth Profiles	A2DP
Bluetooth operating Range	Up to 10 meters

APPENDIX

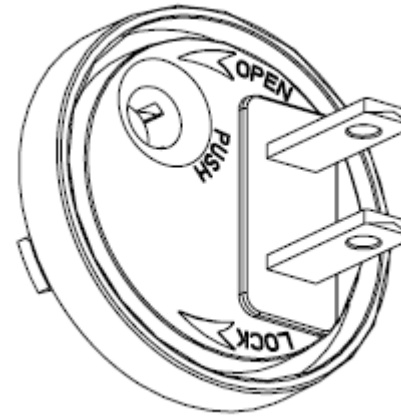

- Hold down the push button then rotate counterclockwise to open the plug from the adapter.
- Hold down the push button then rotate clockwise to lock the plug on the adapter.

Collage

Audio Art : Bluetooth Acoustic Device