

UWB 1-P DWA
Model name : RTU7105 1-P DWA
User's Guide

Revision A

Author : Binson Tseng
Date : 09/06/2008

Table of Contents

1.	Introduction.....	4
2.	System Description	4
2.1.	UWB PHY	6
2.2.	SPI Flash	6
3.	Hardware Interfaces	6
3.1.	USB Interface.....	6
4.	Document History	7
5.	Radiation Exposure Statement.....	7
6.	Interference Statement	7
7.	Coordination Requirements	8

1. Introduction

This document describes the system, operations, and interfaces of the UWB 1-port DWA Hub Demo Board. For WUSB application, the dongle is used as the host controller, and connect to wired USB device with a wireless DWA hub.

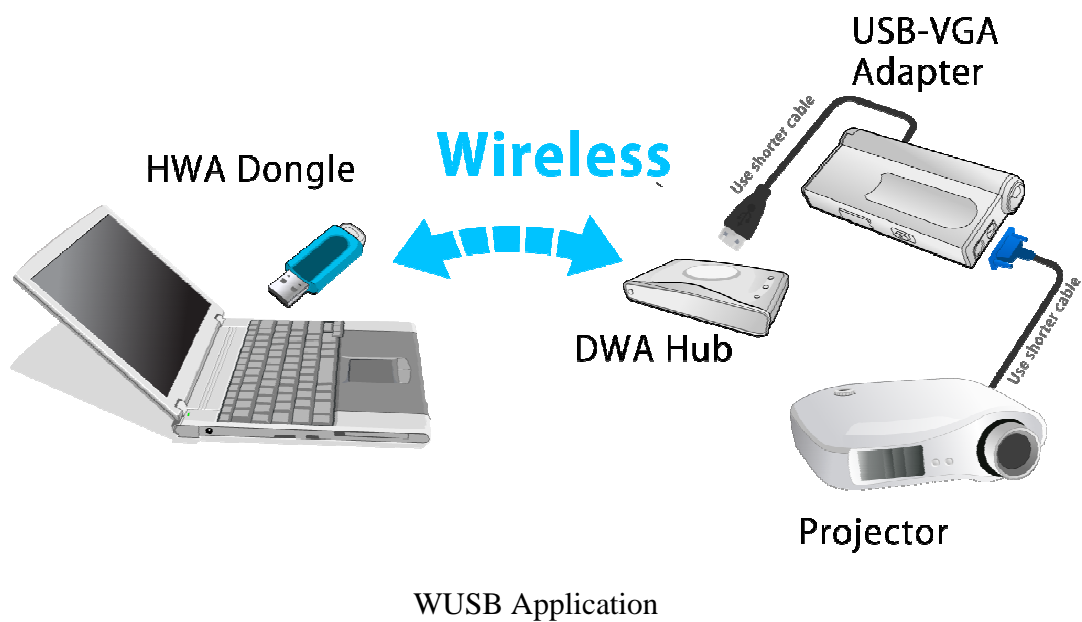

2. System Description

The UWB DWA supports the following functions:

- Certified WUSB mode
- Compliant with USB2.0(max. data rate=480 Mbps)
- Support 53.3M, 80M, 106.7M, 160M, 200M, 320M, 400M, 480Mbps.

The UWB DWA system consists of single chip – Integrated UWB PHY and MAC (RTU7105). A serial flash memory (4Mb) is required to store proper data/commands for the chip. To make the system work properly, the Flash

should be loaded with proper content by using the Flash utility provided by RealTek.

The RF performance can also be tested using the test utility provided by RealTek. One basic clock frequencies are used in the system –66MHz. Some more details of the components are shown in the following sections. The system block diagram is shown below.

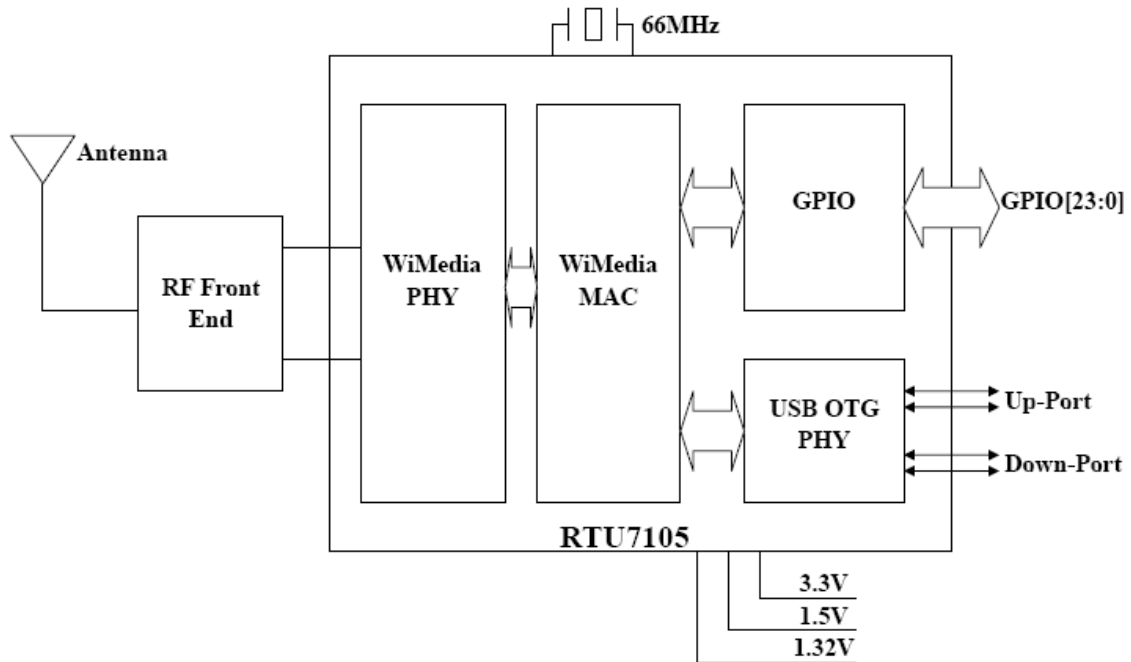

Figure 1 System Block Diagram

Product Specification

Frequency Band	3168MHz ~ 4752MHz
Network Standard	WiMedia PHY 1.1 & MAC 1.0. Support PHY 1.2
Modulation Mode	Multiband OFDM with QPSK, DCM
FEC Coding	Rate 1/3, 1/2, 5/8, 3/4 Convolutional Coding, Reed Solomon Coding
Support Data Rate	8 data rates from 53.3Mbps to 480 Mbps
Interface	USB 2.0 full-speed (12Mbps) and high-speed (480Mbps) interface
Support Applications	Certified WUSB

2.1.UWB PHY

This chip integrates the WiMedia PHY and MAC defined by the standard. This version of chip is packaged in 64-pin QFN form factor. The chip requires 1.5V, 1.32V and 3.3V to operate. High speed USB interface is supported.

2.2. SPI Flash

This chip is a serial flash memory with a capacity of 4Mb. It is used by the MAC to store the initialization data and command sequence required by the MAC and PHY on start up. This chip requires 3.3V only.

3. Hardware Interfaces

3.1. USB Interface

Table 1 USB connector termination assignment

Pin#	Pin Name	Description
1	VBUS	See USB specification
2	D-	See USB specification
3	D+	See USB specification
4	GND	See USB specification
5	SHELL	See USB specification

4. Document History

Date	Revision	Description	Author
09/06/08	A	Initial Release	Binson Tseng

5. Radiation Exposure Statement

This equipment complies with FCC radiation exposure limits set forth for an uncontrolled environment. End users must follow the specific operating instructions for satisfying RF exposure compliance. To maintain compliance with FCC RF exposure compliance requirements, please follow operation instruction as documented in this manual.

This equipment may only be operated indoors. Operation outdoors is in violation of 47 U.S.C. 301 and could subject the operator to serious legal penalties.

6. Interference Statement

This equipment has been tested and found to comply with the limits for a Class B digital device, pursuant to Part 15 of the FCC Rules. These limits are designed to provide reasonable protection against harmful interference in a residential installation. This equipment generates, uses and can radiate radio frequency energy and, if not installed and used in accordance with the instructions, may cause harmful interference to radio communications. However, there is no guarantee that interference will not occur in a particular installation. If this equipment does cause harmful interference to radio or television reception, which can be determined by turning the equipment off and on, the user is encouraged to try to correct the interference by one of the following measures:

- Reorient or relocate the receiving antenna.
- Increase the separation between the equipment and receiver.
- Connect the equipment into an outlet on a circuit different from that to which the receiver is connected.
- Consult the dealer or an experienced radio/TV technician for help.

CAUTION: Any changes of modifications not expressly approved by the grantee of this device could void the user's authority to operate the equipment.

7. Coordination Requirements

For real application, the transmitter will only be active when communicating with the specific receiver through handshaking, acknowledgement and other mechanisms over the wireless channel.

Federal Communication Commission Interference Statement

This equipment has been tested and found to comply with the limits for a Class B digital device, pursuant to Part 15 of the FCC Rules. These limits are designed to provide reasonable protection against harmful interference in a residential installation. This equipment generates, uses and can radiate radio frequency energy and, if not installed and used in accordance with the instructions, may cause harmful interference to radio communications. However, there is no guarantee that interference will not occur in a particular installation. If this equipment does cause harmful interference to radio or television reception, which can be determined by turning the equipment off and on, the user is encouraged to try to correct the interference by one of the following measures:

- Reorient or relocate the receiving antenna.
- Increase the separation between the equipment and receiver.
- Connect the equipment into an outlet on a circuit different from that to which the receiver is connected.
- Consult the dealer or an experienced radio/TV technician for help.

This device complies with Part 15 of the FCC Rules. Operation is subject to the following two conditions: (1) This device may not cause harmful interference, and (2) this device must accept any interference received, including interference that may cause undesired operation.

FCC Caution: Any changes or modifications not expressly approved by the party responsible for compliance could void the user's authority to operate this equipment.

IMPORTANT NOTE:

FCC Radiation Exposure Statement:

This equipment complies with FCC radiation exposure limits set forth for an uncontrolled environment. This equipment should be installed and operated with minimum distance 20cm between the radiator & your body.

This transmitter must not be co-located or operating in conjunction with any other antenna or transmitter.

A UWB device operating under the provisions of this section shall transmit only when it is sending information to an associated receiver. The UWB intentional radiator shall cease transmission within 10 seconds unless it receives an acknowledgement from the associated receiver that its transmission is being received. An acknowledgement of reception must continue to be received by the UWB intentional radiator at least every 10 seconds or the UWB device must cease transmitting.

Per FCC regulations, an intentional radiator may only transmit when communicating with an associated receiver. This continuous transmit mode is for evaluation purpose only.

In end-user applications, this handled through handshaking, acknowledgements, negotiation of the communication channel, and other mechanisms that ensure the transmitter is active when communicating with a receiver.