



# Realtek UWB BG1 HMC User Guide

**Revision B**

**Author : Marco Chuang**

**Date : 2008/04/11**

## Table of Contents

1.	Introduction.....	3
2.	System Description .....	4
2.1.	UWB PHY .....	5
2.2.	UWB MAC.....	5
2.3.	SPI Flash.....	5
3.	Hardware Interfaces .....	6
3.1.	PCIe half mini card Interface .....	6
4.	Document History .....	7
5.	Radiation Exposure Statement.....	7
6.	Interference Statement .....	7
7.	Coordination Requirements .....	8

## 1. Introduction

This document describes the system, operations, and interfaces of the UWB BG1 HMC (half mini card) module. Two main applications are supported by this module. One is wireless USB application and the other one is WiNet mode. For WUSB application, the HMC is used as the host controller, and connect to wired USB device with a wireless DWA hub. WiNet mode is an IP-based network communication, and link up the networks by UWB module.

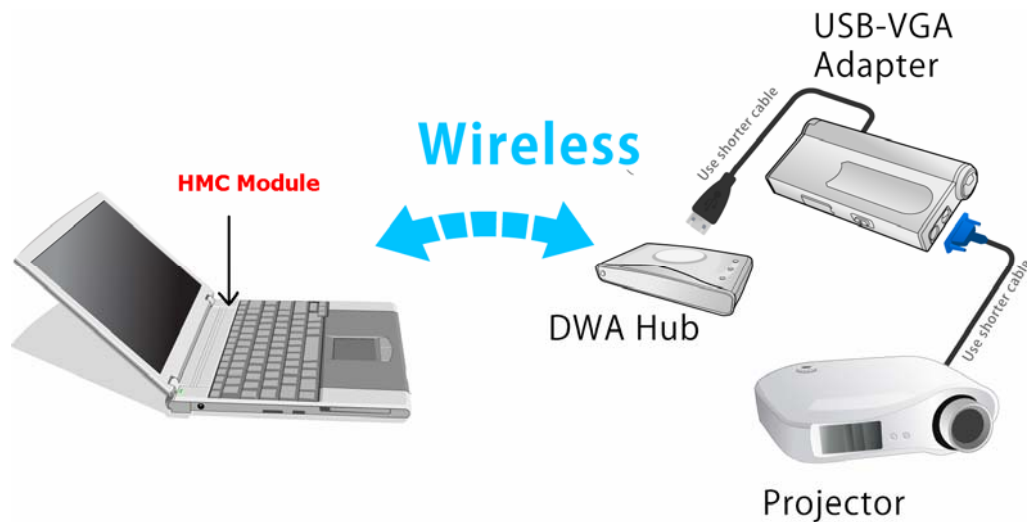

WUSB Application

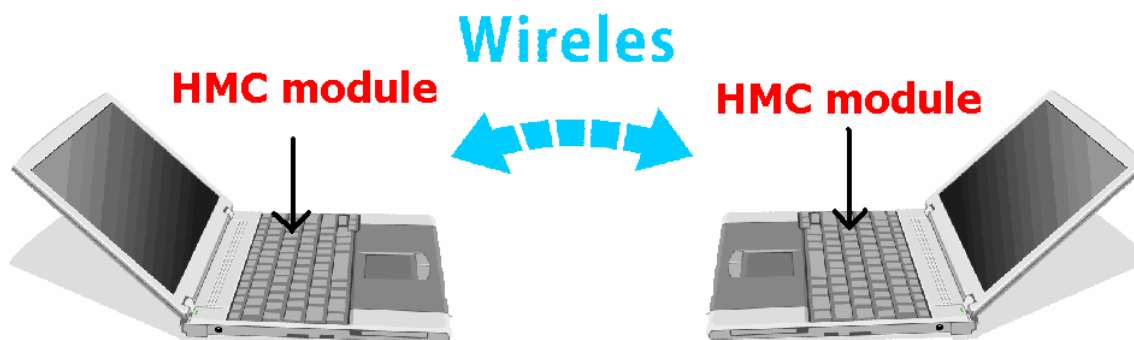

WiNet Application

## 2. System Description

The UWB BG1 HMC module supports the following functions:

- Certified WUSB mode
- WiNet mode
- Support 53.3M, 80M, 106.7M, 160M, 200M, 320M, 400M, 480Mbps.

The module system mainly consists of two main chips – (i) UWB PHY(**RTU7010**), (ii) UWB MAC(**RTU7305**). A serial flash memory(8Mb) is required to store proper data/commands for the PHY chip and MAC chip. To make the system work properly, the Flash should be loaded with proper content by using the Flash utility provided by Realtek.

The RF performance can also be tested using the test utility provided by RealTek. Two basic clock frequencies are used in the system – 12MHz for MAC and 66MHz for PHY. Some more details of the components are shown in the following sections. The system block diagram is shown below.

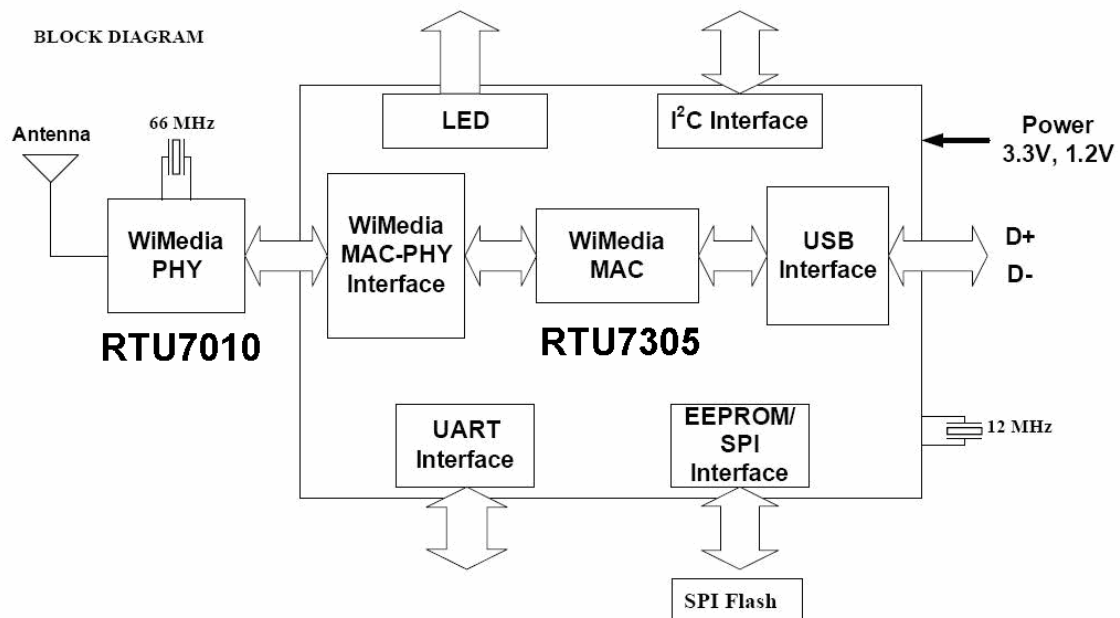

**Figure 1 System Block Diagram**

## Product Specification

Frequency Band	3168MHz ~ 4752MHz
Network Standard	WiMedia PHY 1.1 & MAC 1.0
Modulation Mode	Multiband OFDM with QPSK, DCM
FEC Coding	Rate 1/3, 1/2, 5/8, 3/4 Convolutional Coding, Reed Solomon Coding
Support Data Rate	8 data rates from 53.3Mbps to 480 Mbps
Interface	PCIe half mini card interface
Support Applications	Certified WUSB, WiNet

### 2.1.UWB PHY

This chip integrates the RF and baseband functions of a UWB PHY defined by the standard. This version of PHY chip is packaged in 48-pin QFN form factor. The analog/RF section requires 1.8V and 3.3V to operate. The digital core operates with 1.5V and the I/O voltage can support a range of 1.8V~3.3V.

### 2.2. UWB MAC

This MAC chip is also from RealTek which has a standard MPI interface to communicate with a standard UWB PHY, as well as a high speed USB interface to connect directly to a PC. This chip requires voltages of 1.2V and 3.3V.

### 2.3. SPI Flash

This chip is a serial flash memory from Macronix with a capacity of 8Mb. It is used by the MAC to store the initialization data and command sequence required by the MAC and PHY on start up. This chip requires 3.3V only.

### 3. Hardware Interfaces

#### 3.1. PCIe half mini card Interface

Table 1 half mini card connector termination assignment

Pin #	Name	Pin #	Name
51	Reserved*	52	+3.3V
49	Reserved*	50	GND
47	Reserved*	48	+1.5V
45	Reserved*	46	LED_WPAN#
43	Reserved*	44	LED_WLAN#
41	Reserved*	42	LED_WWAN#
39	Reserved*	40	GND
37	Reserved*	38	USB_D+
35	GND	36	USB_D-
33	PETp0	34	GND
31	PETn0	32	SMB_DATA
29	GND	30	SMB_CLK
27	GND	28	+1.5V
25	PERp0	26	GND
23	PERn0	24	+3.3Vaux
21	GND	22	PERST#
19	Reserved*** (UIM_C4)	20	W_DISABLE#
17	Reserved*** (UIM_C8)	18	GND
Mechanical Key			
15	GND	16	UIM_VPP
13	REFCLK+	14	UIM_RESET
11	REFCLK-	12	UIM_CLK
9	GND	10	UIM_DATA
7	CLKREQ#	8	UIM_PWR
5	Reserved**	6	1.5V
3	Reserved**	4	GND
1	WAKE#	2	3.3V

## 4. Document History

<b>Date</b>	<b>Revision</b>	<b>Description</b>	<b>Author</b>
2008/03/25	A	Initial Release	Marco Chuang
2008/04/11	B	Modify Chapter 5&7	Marco Chuang

## 5. Radiation Exposure Statement

This equipment complies with FCC radiation exposure limits set forth for an uncontrolled environment. End users must follow the specific operating instructions for satisfying RF exposure compliance. To maintain compliance with FCC RF exposure compliance requirements, please follow operation instruction as documented in this manual.

## 6. Interference Statement

This equipment has been tested and found to comply with the limits for a Class B digital device, pursuant to Part 15 of the FCC Rules. These limits are designed to provide reasonable protection against harmful interference in a residential installation. This equipment generates, uses and can radiate radio frequency energy and, if not installed and used in accordance with the instructions, may cause harmful interference to radio communications. However, there is no guarantee that interference will not occur in a particular installation. If this equipment does cause harmful interference to radio or television reception, which can be determined by turning the equipment off and on, the user is encouraged to try to correct the interference by one of the following measures:

- Reorient or relocate the receiving antenna.
- Increase the separation between the equipment and receiver.
- Connect the equipment into an outlet on a circuit different from that to which the receiver is connected.
- Consult the dealer or an experienced radio/TV technician for help.

**CAUTION:** Any changes of modifications not expressly approved by the grantee of this device could void the user's authority to operate the equipment.

## 7. Coordination Requirements

For real application, the transmitter will only be active when communicating with the specific receiver through handshaking, acknowledgement and other mechanisms over the wireless channel.

### **Federal Communication Commission Interference Statement**

This equipment has been tested and found to comply with the limits for a Class B digital device, pursuant to Part 15 of the FCC Rules. These limits are designed to provide reasonable protection against harmful interference in a residential installation. This equipment generates, uses and can radiate radio frequency energy and, if not installed and used in accordance with the instructions, may cause harmful interference to radio communications. However, there is no guarantee that interference will not occur in a particular installation. If this equipment does cause harmful interference to radio or television reception, which can be determined by turning the equipment off and on, the user is encouraged to try to correct the interference by one of the following measures:

- Reorient or relocate the receiving antenna.
- Increase the separation between the equipment and receiver.
- Connect the equipment into an outlet on a circuit different from that to which the receiver is connected.
- Consult the dealer or an experienced radio/TV technician for help.

This device complies with Part 15 of the FCC Rules. Operation is subject to the following two conditions: (1) This device may not cause harmful interference, and (2) this device must accept any interference received, including interference that may cause undesired operation.

**FCC Caution:** Any changes or modifications not expressly approved by the party responsible for compliance could void the user's authority to operate this equipment.

This transmitter must not be co-located or operating in conjunction with any other antenna or transmitter.

A UWB device operating under the provisions of this section shall transmit only when it is sending information to an associated receiver. The UWB intentional radiator shall cease transmission within 10 seconds unless it receives an acknowledgement from the associated receiver that its transmission is being received. An acknowledgement of reception must



continue to be received by the UWB intentional radiator at least every 10 seconds or the UWB device must cease transmitting.

Per FCC regulations, an intentional radiator may only transmit when communicating with an associated receiver. In end-user applications, this is achieved through the handshaking, acknowledgements, negotiation of the communication channel, and other mechanisms those will ensure that the transmitter is activated only when communicating with a receiver. The continuous transmitting mode is for compliance and evaluation purpose only and is not available to the end user.