



PRELIMINARY

INSTALLATION INSTRUCTIONS

**WIRELESS UNIVERSAL
STRIKE INTERFACE
(WUSI)**

RECOGNITION  SOURCE

**3820 Stern Avenue
St. Charles, IL 60174
Phone: 630-762-4450
Fax: 630-762-4455
P/N: M053-xxx-x001**

INSTALLATION INSTRUCTIONS

Wireless Universal Strike Interface (WUSI)

NOTE: These instructions are for installing the Wireless Universal Strike Interface (WUSI), a component of a Wyreless Access System. After completing this installation refer to the “Configuring and Operating the Wyreless Access System” manual.

Table of Contents

1. Wyreless Access™ System Components.....	3
1.1 Overview	3
1.2 Wireless Universal Strike Interface (WUSI) Components & Sales Models	4
2. Installing the WUSI	4
2.1 Tools – Hardware Required.....	4
2.2 Determining the Best WPIM and WUSI Locations.....	5
2.3 Mounting the WUSI	6
2.4 Getting Wires In & Out of the WUSI.....	7
2.5 Wiring the WUSI to its Access Control Peripherals.....	8
3. WUSI Cable/Wire Specifications	14
4. Contacting Recognition Source	15
5. FCC Compliance & Warnings.....	16
5.1 FCC Compliance	16
5.2 UL Compliance.....	16
5.3 Warnings.....	16
6. Revision History.....	17

1. Wyreless Access™ System Components

1.1 Overview

Every access control system that uses Wyreless Access™ contains two different types of modules (Figure 1-1):

- at least one Wyreless Panel Interface Module (WPIM), and
- at least one Wyreless Access Point Module (WAPM)

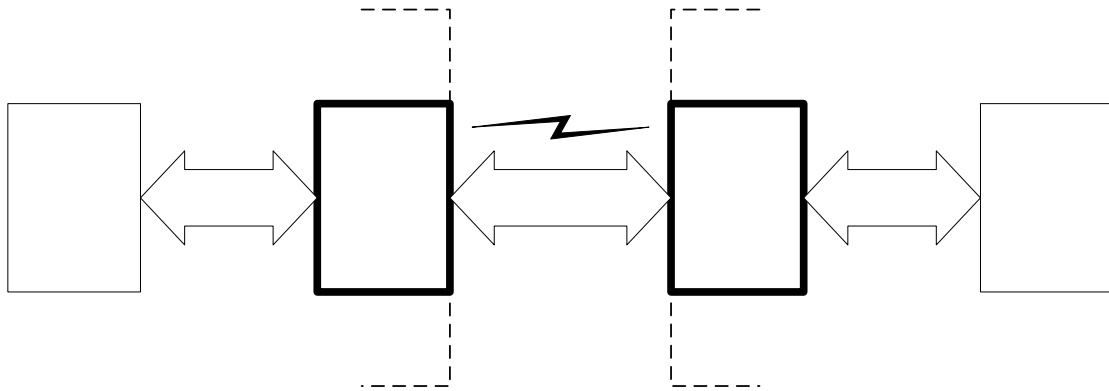

Figure 1-1 – Wyreless Access System Block Diagram

Recognition Source’s product line contains several different expressions of each module.

The WPIM is wired to the access control panel and ideally is installed very close to the access control panel. The WPIMs installation location is determined by the location of the WAPMs with which it will communicate using RF.

The WAPM is installed at the access point where access will be controlled and/or monitored. Depending on the application and which WAPM is used, some wiring at the access control point may be required.

Regardless of which WPIM or WAPM module is used, the communication link between the WPIM and WAPM is always RF.

This manual describes the installation of a Wireless Universal Strike Interface (WUSI) which is a WAPM.

1.2 Wireless Universal Strike Interface (WUSI) Components & Sales Models

The WUSI (Figure 1-2 & Figure 1-3) includes the following components:

- a reader/keypad connector
- strike relay connector
- door position input
- request to exit input
- request to enter input
- tamper input & tamper switch
- flash programming port
- RF Transceiver

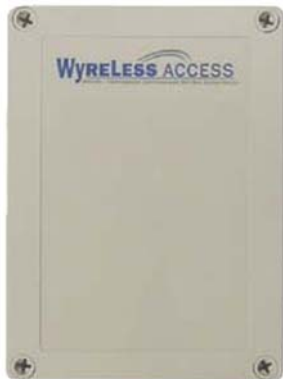

Figure 1-2 – Front of the WUSI



Figure 1-3 – Inside the WUSI

MODEL	MOUNTING	LOCATION
WUSI	surface	indoor

Table 1-1- WUSI Sales Model Table

2. Installing the WUSI

2.1 Tools – Hardware Required

- Hammer
- 9/32” & 3/4” drill bits (the size will depend on the mounting fasteners used)
- Flat and Phillips head screwdrivers (1/8” wide flat blade for screw terminals)
- Pencil
- Mounting Kit (K381-000-001), provided, including four zinc, pan head Phillips, 8-18 X 1 ½” sheet metal screws and four heavy-duty anchors
- Mounting Kit (K384-003-001), provided, including four #8 X 2 ½” screws and four 1” round by 1” high (1” O.D. x 1”) spacers

2.2 Determining the Best WPIM and WUSI Locations

Proper selection of WPIM and WUSI module mounting locations insures reliable RF communications.

The WPIM manual contains a section for determining the best location for the WPIM.

The maximum distance between WPIM and a WUSI is 200' horizontally when installed inside a building on the same floor that uses normal building construction materials. Never locate the WUSI and WPIM more than one (1) floor apart. If on different floors, limit the maximum horizontal distance to 100'. The maximum distance is 1000' for a line of sight installation.

The maximum distance between WPIM and a WUSI is 200' horizontally when installed inside a building that uses normal building construction materials. The maximum distance is 1000' for a line of sight installation.

This section provides additional application specific help and guidelines to select the best mounting location for the WUSI Transceiver Control Box:

- Mount the WUSI Transceiver Control Box inside the protected area.
- Mount the WUSI Transceiver Control Box on the wall, at least 55" from the floor
- Mount the WUSI Transceiver Control Box within 500' cable feet of the Card Reader or other input device
- Mount the WUSI Transceiver Control Box within 500' cable feet of the Strike.
- A WUSI must, in all directions (sides, top, bottom, and back), have a minimum 1" separation from any metal surface. Therefore if the WUSI must be mounted on a metal surface, though not recommended, the supplied 1" spacer kit (K384-003-001) must be used.

NOTE: A WUSI located with a substantial steel barrier intervening between it and the WPIM may require alternate WUSI and/or WPIM placement in order to ensure reliable RF communications. In these applications, mount the WPIM remote from the access control panel. Choose the WPIM or the WPIM's Remote Antenna location to prevent "shadowing" of the WUSI from WPIM radio transmissions.

2.3 Mounting the WUSI

- 2.3.1 **TRANSCEIVER CONTROL BOX** – A 1” hole is provided in the back of the Transceiver Control Box for routing wires in & out. If needed, additional hole(s) can be drilled in the lower left hand corner of the Transceiver Control Box. Wire routing inside the enclosure is very important. Improper wire routing will reduce the RF range. Keep the wires inside the enclosure as short as possible (i.e. do not coil any excess wire inside the enclosure) (Figure 2-1 & Figure 2-2).



Figure 2-1 – Improper Wire Routing



Figure 2-2 – Proper Wire Routing

- 2.3.1.1 Remove the Transceiver Control Box cover.
- 2.3.1.2 Place the Transceiver Control Box (cover removed) against the wall in the position it was successfully “link” tested.
- 2.3.1.3 Using Transceiver Control Box as a template, mark the four corner mounting holes and the ½” wire hole (if used) with a pencil.
- 2.3.1.4 Drill a 9/32” hole at each mounting mark, 1 ¼” deep, and a ½” hole at the wire hole mark (if used).
- 2.3.1.5 Insert the four anchors provided firmly into the holes so they are flush with the wall.
- 2.3.1.6 Depending on the installation, you may want to screw the Transceiver Control Box to the wall now or wait until the rest of the components are installed to facilitate wire routing.

If the WUSI is to be mounted on a non-metallic surface use the #8, 1½” screws provided (kit: K381-000-001) to attach the WUSI to the wall..

If the WUSI is to be mounted on a metallic surface use the round 1” high spacers and the #8, 2½” screws provided (kit: K384-003-001) to attach the WUSI 1” from the wall.

- 2.3.2 **CARD READER** – If the installation uses a card reader or other input device, mount it using the manufacturer’s installation instructions. Route the card reader wires into the Transceiver Control Box.
- 2.3.3 **STRIKE** - If the installation uses a strike device, mount it using the manufacturer’s installation instructions. Route the strike device wires into the Transceiver Control Box.
- 2.3.4 **DOOR POSITION SWITCH** – If the installation uses a door position switch, mount it using the manufacturer’s installation instructions. Route the door position switch wires into the Transceiver Control Box.

- 2.3.5 **REQUEST TO EXIT DEVICE** – If the installation uses a separate request to exit device, mount it using the manufacturer’s installation instructions. Route the request to exit device wires into the Transceiver Control Box.
- 2.3.6 **REQUEST TO ENTER DEVICE** – If the installation uses a request to enter device, mount it using the manufacturer’s installation instructions. Route the request to enter device wires into the Transceiver Control Box.

2.4 Getting Wires In & Out of the WUSI

The back of the WUSI enclosure has a pre-drilled hole for getting wires in & out of the WUSI. For optimum WUSI performance, this wire hole must be used.

If holes must be drilled in the WUSI enclosure determine the size and number of entry/exit connectors to be used.

Use entry/exit wiring connectors/glands that are compliant with local electrical codes (i.e. conduit, etc.)

NOTE: *When drilling, make certain that the drill bit does not damage any electronics inside the enclosure. Use light drill pressure so that the bit does not enter the enclosure very far when the bit breaks through the inside of the enclosure.*

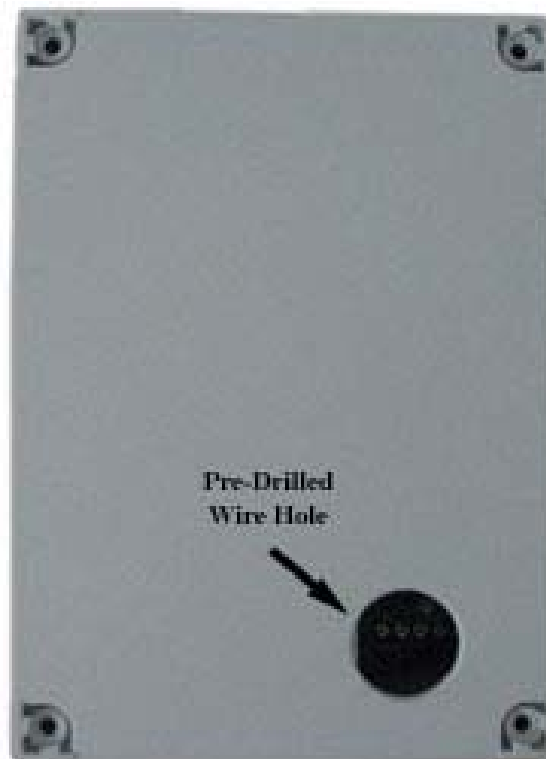

Figure 2-3 – Rear of WUSI Enclosure

2.5 Wiring the WUSI to its Access Control Peripherals

There are seven WUSI PCB connectors that provide connections to Access Control Peripherals that the WUSI will monitor and/or control (Figure 2-4):

- DC Input Power
- Tamper Input
- Door Position Input
- Request to Exit Input
- Request to Enter Input
- Portal Output
- Card Reader

Some of the connections are optional based on the specific application of the WUSI. Refer to Section 3 for cable and wire specifications for the WUSI.

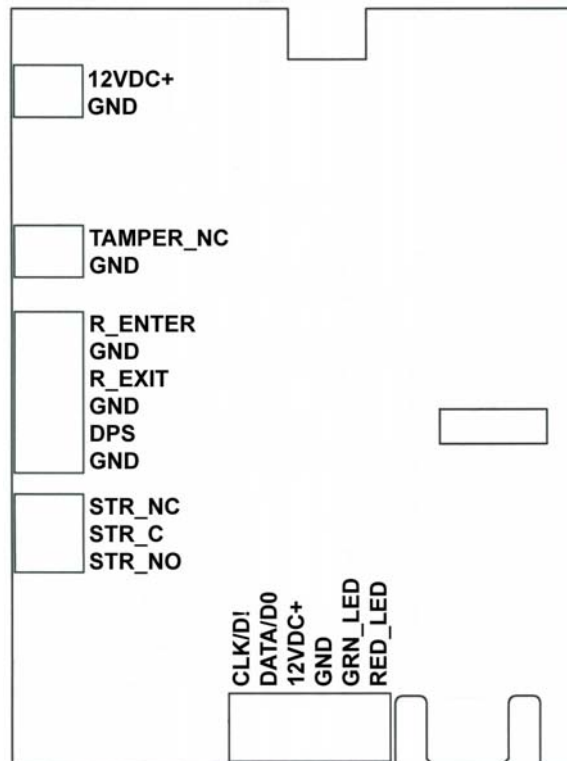

Figure 2-4 – WUSI Printed Circuit Board (PCB) Connections

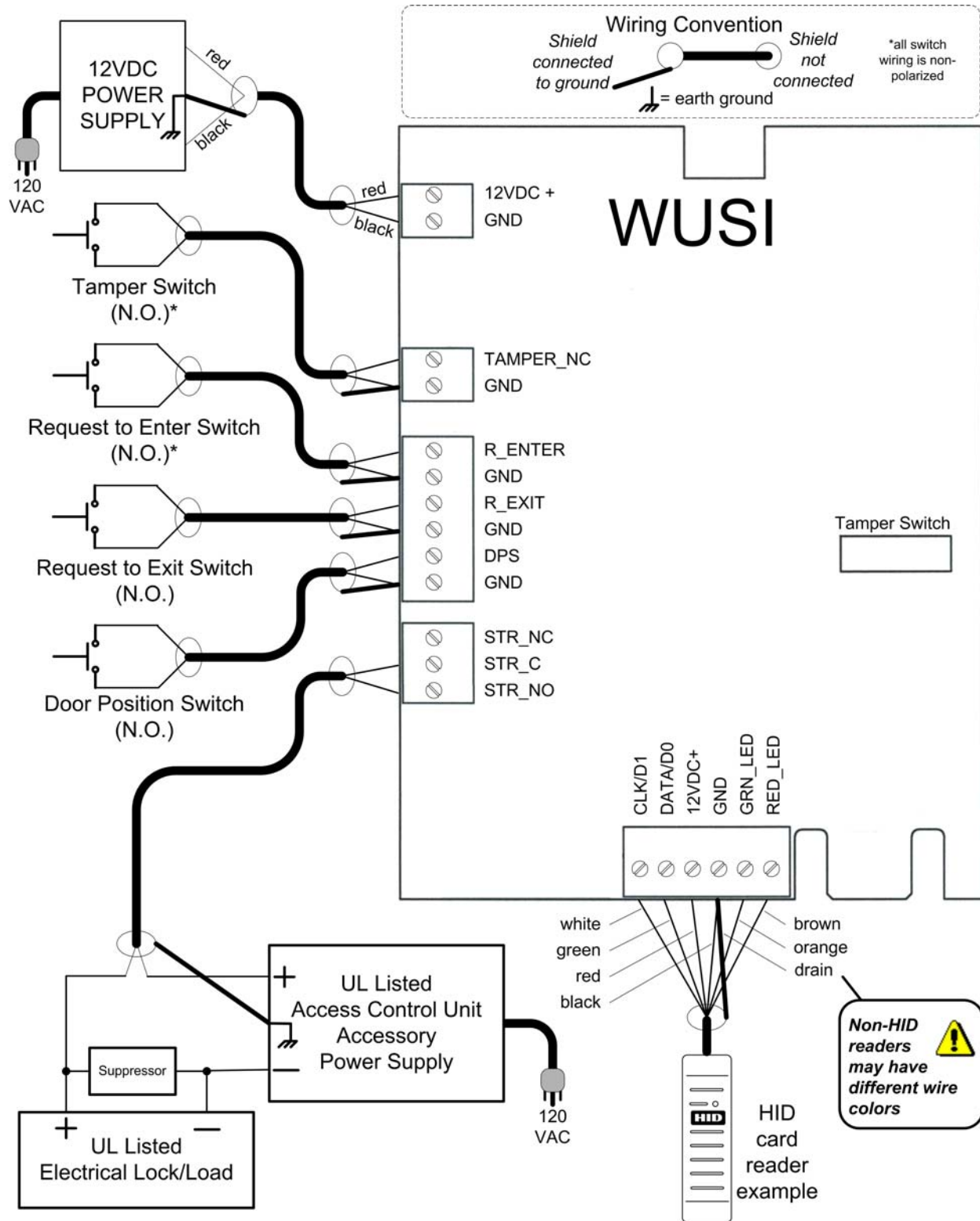

Figure 2-5 – Typical Access Point Configuration

2.5.1 DC Input Power

The DC Input Power connection is mandatory. An external, UL approved, DC power supply that can supply typically 12 VDC (7-14VDC range) must be provided. The DC power supply must be capable of providing 300 mA of current to power the WUSI. Add the power requirements of the access control peripherals connected to the WUSI to the 300 mA to determine the overall size of the DC power supply.

Figure 2-4 shows where the DC power is connected to the WUSI PCB. Table 2-1 shows how to connect the DC power. Make certain to observe the polarity.

Connect the shield of the DC Input Power cable to the Ground (-) terminal at the power supply. Do not connect the cable shield at the WUSI (Figure 2-5).

DC INPUT POWER	12VDC+	The WSUI typically operates from 12 VDC and draws 300mA peak maximum. This does not include the power consumption required by the peripherals (strike, reader, etc).
	GND	

Table 2-1 – DC Input Power Connections

2.5.2 Tamper Input

The Tamper Input connection is optional and provides a way of monitoring and external tamper switch. The Tamper Input is in parallel with the Tamper Switch, SW1, on the WUSI PCB. SW1 monitors the state of the WUSI enclosure door and generates a tamper trouble when the door is open. If other possible tamper conditions (i.e. power supply enclosures, gate controllers, etc.) need to be monitored, wire a single pole, single throw (SPST) to the Tamper Input. When terminals TAMPER_NC & GND (Figure 2-4) are shorted, a tamper trouble signal is generated (Table 2-2).

Connect the shield of the Tamper Input cable to the WUSI GND). Do not connect the cable shield at the Tamper Switch (Figure 2-5).

The Tamper Input connection is not connected in UL installations.

TAMPER	TAMPER_NC	A dry contact closure across these terminals causes a tamper trouble signal to be sent to the ACP
	GND	

Table 2-2 – Tamper Input Connections

2.5.3 Portal Inputs

The portal inputs consist of a Request to Enter, Request to Exit, and Door Position Switch inputs. Wiring any or all of the Portal Inputs is optional based on the WUSI application. All three inputs are expecting an open circuit or a short circuit across their terminals.

When terminals R_ENTER & GND (Figure 2-4) are shorted, a “Request to Enter” signal is generated (Table 2-3).

When terminals R_EXIT & GND (Figure 2-4) are shorted, a “Request to Exit” signal is generated (Table 2-3).

When terminals DPS & GND (Figure 2-4) are shorted, a “Portal Closed” signal is generated. When terminals DPS & GND are open, a “Portal Open” signal is generated (Table 2-3).

Connect the shield of the Portal Input cables to the appropriate WUSI GND terminal.. Do not connect the cable shield at the Request to Enter, Request to Exit, or Door Position Switches (Figure 2-5).

REQUEST TO ENTER	R_ENTER	A dry contact closure across these terminals initiates a request to enter.
	GND	
REQUEST TO EXIT	R_EXIT	A dry contact closure across these terminals initiates a request to exit.
	GND	
DOOR POSITION SWITCH	DPS	A dry contact closure across these terminals indicates to the ACP that the access point portal is closed. An open circuit indicates to the ACP that the access point portal is open.
	GND	

Table 2-3 – Portal Inputs Connections

2.5.4 Portal Output

The Portal Output consists of a Strike Relay with form C outputs (common, normally open, and normally closed). Wiring of the Portal Output is optional based on the WUSI application.

When the portal is unlocked, the Strike Relay Output turns on indicating that the portal should be unlocked. Therefore the appropriate side of the relay contact (normally open or normally closed) must be used to make certain that when the relay is de-energized that the portal is locked and when the relay is energized that the portal is unlocked.

STRIKE RELAY OUTPUT	STR_NC	Strike output, isolated form C contact rated 30VAC/VDC, 5A (silver alloy contacts for heavy loads).
	STR_C	
	STR_NO	

Table 2-4 – Portal Output Connection

A Suppressor must be installed with every electrical switching device run through the Portal Output relay contact. The Suppressor protects the WUSI from the power generated by the collapsing magnetic field of an electrical load. The Suppressor will maximize the life of the WUSI.

Follow the Electrical Lock/Load manufacturer’s recommendation for suppression of magnetic/inductive loads. A properly rated bi-directional Tranzorb (Silicon Avalanche Diode) may also be used. Install the Suppressor within 18 inches of the electrical load (Figure 2-6).

NOTE: The Portal Output must utilize a dedicated shielded cable to prevent transient contamination of other WUSI signal wiring. Do not run the Portal Output wires in the same cable or conduit as any other WUSI wiring. The Portal Output wiring should be at least 12 inches away from any other WUSI wiring or it should be run in a separate conduit.

Connect the shield of the Portal Output cables to the appropriate WUSI J7-6 terminal (GND). Do not connect the cable shield at the Electrical Lock/Load (Figure 2-5).

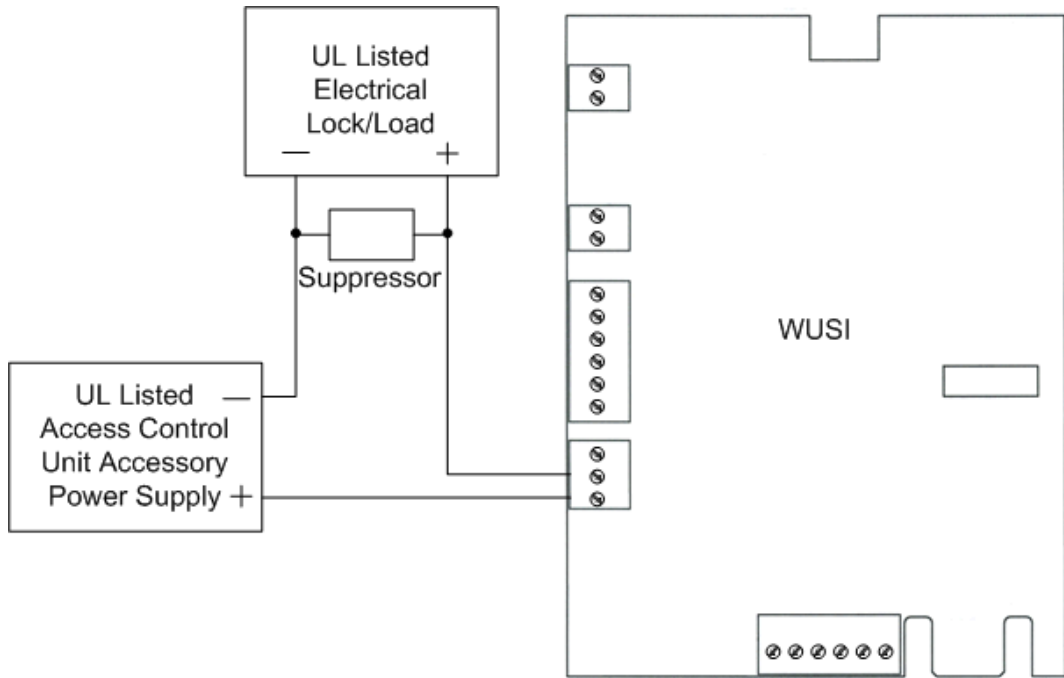

Figure 2-6 – Portal Output Suppression Diagram

2.5.5 Card Reader/Keypad

Any input device with a Wiegand or Clock & Data bit stream can be used with the WUSI. A transaction must be a single bit stream of between 8 and 255 bits. Devices which output individual characters/digits are not acceptable.

The WUSI provides a Card Reader interface. Wiring of the Card Reader is optional based on the WUSI application.

Take the power requirements of the Card Reader into consideration when sizing the power supply for the WUSI and its peripherals (Section 2.5.1).

Card Reader connections are shown in Table 2-5.

Connect the Card Reader cable shield to the WUSI GND terminal on the Card Reader connector. Do not connect the cable shield at the Card Reader (Figure 2-5).

CARD READER	CLK/D1	Card Reader inputs, each input line has a 3.3k pull up resistor to 5V, and a 12V transient suppressor to GND.
	DATA/D0	
	12VDC+	Reader power supply output. The WUSI PC board routes its own power supply input to these terminals, so the readers see the same supply as the WUSI. If other than 12 VDC is required for the input device, then a separate input device power supply must be used. Make certain that a common ground connection is established between the input device's power supply and the WUSI.
	GND	
	GRN_LED	Green LED signal line. This signal goes to ground through 100ohm when activated. When deactivated, it is pulled up to +5V through 1.1kohm.
	RED_LED	Red LED signal line. Same functionality as GRN line, except RED.

Table 2-5 – Card Reader Connections

3. WUSI Cable/Wire Specifications

Application	Part Number	AWG	Description	Maximum Distance
DC Power Input	Belden 8760	18	2 conductor	1,000'
Tamper	Belden 8760	18	twisted pair shielded	2,000'
Request to Enter	Belden 8760	18	twisted pair shielded	2,000'
Request to Exit	Belden 8760	18	twisted pair shielded	2,000'
Door Position Switch	Belden 8760	18	twisted pair shielded	2,000'
Strike Relay Output	Belden 8760	18	twisted pair shielded	2,000'
Card Reader	Alpha 1296C	22	6 conductor shielded	500'

Table 3-1 – WUSI Cable/Wire Specifications

This completes the installation of the WUSI.

If the Wyreless Panel Interface Module (WPIM) that will control this WUSI is not installed, now is the time to install it, please refer to the “PIM Installation Instruction” manual.

If the WPIM is installed, then you are ready to configure your Wyreless Access System, please refer to the “Configuring & Operating a Wyreless Access System” manual.

4. Contacting Recognition Source

For questions regarding Wyreless Access™:

(630) 762-4450
(630) 762-4444 fax

5. FCC Compliance & Warnings

5.1 FCC Compliance

- This device has been authorized by the FCC Rules and Industry Canada.
- This device complies with the limits for a Class B digital device and a Class B intentional radiator, pursuant to Part 15 of the FCC Rules and with RSS-210 of Industry Canada. Operation is subject to the following two conditions: (1) This device may cause harmful interference, and (2) this device must accept any interference received, including interference that may cause undesired operation.
- The Wyreless Access System Component must be installed by qualified professionals or contractors in accordance with FCC part 15.203, Antenna Requirements.
- Do not use any antenna other than the one provided with the unit.

5.2 UL Compliance

- The Wireless Universal Strike Interface (WUSI) listing under UL294 as an access control system accessory is pending.
- Access equipment manufactured and/or sold by Recognition Source, LLC, is not rated for, or intended for use in life safety installations.
- UL listed panic hardware shall be used to allow emergency exit from the protected area.
- UL listed compatible readers: HID, Model PROXPOINT.
- Use Recognition Source Power Supply, model PS-12VDCR-500mA UL listed class 2 power supply.

5.3 Warnings

- RF Exposure - To comply with FCC RF exposure requirements for mobile transmitting devices this transmitter should only be used or installed at locations where there is normally at least a 20 cm separation between the antenna and all persons.
- Do not co-locate and operate in conjunction with any other antenna or transmitter.
- Changes or modifications not expressly approved by Recognition Source could void the user's authority to operate the equipment.

6. Revision History

Version	Date	Changes
x001	11/26/03	preliminary in house release for comments