

# Gas 310 ECO PRO - Gas 610 ECO PRO



## Installation, User and Service Manual

# EC declaration of conformity

---

The device complies with the standard type described in the EG declaration of conformity. It was manufactured and commissioned in accordance with European directives.

The original declaration of conformity is available from the manufacturer.

# Contents

---

<b>1</b>	<b>Introduction .....</b>	<b>6</b>
	<b>1.1 Symbols used .....</b>	<b>6</b>
	<b>1.2 Abbreviations .....</b>	<b>6</b>
	<b>1.3 Liabilities .....</b>	<b>7</b>
	1.3.1 Manufacturer's liability .....	7
	1.3.2 Installer's liability .....	7
	1.3.3 User's liability .....	7
<b>2</b>	<b>Safety instructions and recommendations .....</b>	<b>9</b>
	<b>2.1 Safety instructions .....</b>	<b>9</b>
	<b>2.2 Recommendations .....</b>	<b>9</b>
<b>3</b>	<b>Technical description .....</b>	<b>11</b>
	<b>3.1 General description .....</b>	<b>11</b>
	<b>3.2 Homologations .....</b>	<b>11</b>
	3.2.1 Certifications .....	11
	3.2.2 Equipment categories .....	12
	3.2.3 Type plate .....	12
	3.2.4 Factory test .....	12
	<b>3.3 Main parts .....</b>	<b>13</b>
	3.3.1 Boiler type Gas 310 ECO PRO .....	13
	3.3.2 Boiler type Gas 610 ECO PRO .....	14
	3.3.3 System pump .....	14
	3.3.4 Regulation of the water temperature .....	15
	3.3.5 Protection against a shortage of water .....	15
	3.3.6 Maximum temperature protection .....	15
	3.3.7 Air differential pressure switch .....	15
	<b>3.4 Technical specifications .....</b>	<b>15</b>
	3.4.1 Boiler type Gas 310 ECO PRO .....	15
	3.4.2 Boiler type Gas 610 ECO PRO .....	17
<b>4</b>	<b>Installation .....</b>	<b>19</b>
	<b>4.1 Regulations governing installation .....</b>	<b>19</b>
	<b>4.2 Package list .....</b>	<b>19</b>
	4.2.1 Standard delivery .....	19
	4.2.2 Accessories .....	19
	<b>4.3 Installation options .....</b>	<b>20</b>
	4.3.1 Transport .....	20

4.3.2	Location of the boiler .....	21
4.3.3	Main dimensions .....	26
<b>4.4</b>	<b>Hydraulic connections .....</b>	<b>28</b>
4.4.1	Flushing the system .....	28
4.4.2	Connection of the heating circuit .....	28
4.4.3	Connecting the condensate discharge pipe .....	29
<b>4.5</b>	<b>Gas connection .....</b>	<b>30</b>
<b>4.6</b>	<b>Connections for the air and exhaust pipes .....</b>	<b>30</b>
4.6.1	Classification .....	31
4.6.2	Outlets .....	31
4.6.3	Lengths of the air/flue gas pipes .....	32
4.6.4	Additional Directives .....	35
4.6.5	Connection of the combustion gas exhaust pipe .....	35
4.6.6	Connection of the air intake pipe .....	36
<b>4.7</b>	<b>Electrical connections .....</b>	<b>36</b>
4.7.1	Control unit .....	37
4.7.2	Recommendations .....	38
4.7.3	Standard control PCB .....	38
4.7.4	Connecting the on/off control .....	40
4.7.5	Connecting modulating controller .....	40
4.7.6	Shutdown input .....	40
4.7.7	Release input .....	41
4.7.8	System pump .....	41
4.7.9	PC/Laptop connection .....	41
4.7.10	Connection possibilities for the PCB (SCU-S05) .....	42
<b>4.8</b>	<b>Electrical diagram .....</b>	<b>47</b>
<b>4.9</b>	<b>Filling the system .....</b>	<b>47</b>
4.9.1	Water treatment .....	48
4.9.2	Filling the siphon .....	48
4.9.3	Filling the system .....	49
<b>5</b>	<b>Commissioning .....</b>	<b>50</b>
<b>5.1</b>	<b>Control panel .....</b>	<b>50</b>
5.1.1	Functions of the keys .....	50
5.1.2	Meaning of the symbols on the display .....	50
<b>5.2</b>	<b>Check points before commissioning .....</b>	<b>51</b>
5.2.1	Preparing the boiler for commissioning .....	51
5.2.2	Gas circuit .....	52
5.2.3	Hydraulic circuit .....	52
5.2.4	Connections for the air and exhaust pipes .....	52
5.2.5	Electrical connections .....	52
<b>5.3</b>	<b>Commissioning the boiler .....</b>	<b>52</b>
<b>5.4</b>	<b>Gas settings .....</b>	<b>53</b>
5.4.1	Setting the air/gas ratio (Full load) .....	54

	5.4.2	Setting the air/gas ratio (Part load) .....	55
<b>5.5</b>	<b>Checks and adjustments after commissioning .....</b>		<b>56</b>
	5.5.1	Finalizing work .....	56
<b>5.6</b>	<b>Reading out measured values .....</b>		<b>56</b>
	5.6.1	Reading the various current values .....	56
<b>5.7</b>	<b>Changing the settings .....</b>		<b>57</b>
<b>6</b>	<b>Switching off the boiler .....</b>		<b>58</b>
	<b>6.1</b>	<b>Installation shutdown .....</b>	<b>58</b>
	<b>6.2</b>	<b>Antifreeze protection .....</b>	<b>58</b>
<b>7</b>	<b>Checking and maintenance .....</b>		<b>59</b>
	<b>7.1</b>	<b>General .....</b>	<b>59</b>
	<b>7.2</b>	<b>Standard checks .....</b>	<b>59</b>
	7.2.1	Checking the hydraulic pressure .....	60
	7.2.2	Checking the ionization current .....	60
	7.2.3	Check the water quality .....	60
	7.2.4	Checking the air supply connections and flue gas discharge connections .....	60
	7.2.5	Checking the gas filter for pollution .....	61
	7.2.6	Checking combustion .....	61
	7.2.7	Check the air supply hose .....	62
	7.2.8	Check the dirt trap .....	62
	7.2.9	Check the air box .....	62
	7.2.10	Check the air pressure differential switch PS .....	63
	7.2.11	Check the gas leakage control VPS .....	64
	7.2.12	Check the minimum gas pressure switch Gps .....	66
	<b>7.3</b>	<b>Specific maintenance operations .....</b>	<b>66</b>
	7.3.1	Clean the fan and the venturi .....	67
	7.3.2	Clean and inspect the non-return valve .....	68
	7.3.3	Replacing the ionization/ignition electrode .....	68
	7.3.4	Cleaning the gas filter .....	69
	7.3.5	Cleaning the burner .....	70
	7.3.6	Clean the burner area .....	70
	7.3.7	Checking the heat exchanger .....	71
	7.3.8	Cleaning the condensate collector .....	72
	7.3.9	Cleaning the siphon .....	72
	7.3.10	Assembling the boiler .....	73
	7.3.11	Put the boiler back into operation .....	73
<b>8</b>	<b>Troubleshooting .....</b>		<b>74</b>
	<b>8.1</b>	<b>Shutdowns and lock-outs .....</b>	<b>74</b>
	8.1.1	General .....	74
	8.1.2	Blocking .....	74
	8.1.3	Lock out .....	74

	8.1.4	Error memory .....	75
<b>9</b>		<b>Spare parts .....</b>	<b>76</b>
	<b>9.1</b>	<b>General .....</b>	<b>76</b>
<b>10</b>		<b>Checklists .....</b>	<b>77</b>
	<b>10.1</b>	<b>Checklist for commissioning .....</b>	<b>77</b>
	<b>10.2</b>	<b>Checklist for periodic inspection and maintenance .....</b>	<b>78</b>



# 1 Introduction

---

## 1.1 Symbols used

---

In these instructions, various danger levels are employed to draw the user's attention to particular information. In so doing, we wish to safeguard the user's safety, obviate hazards and guarantee correct operation of the appliance.

**DANGER**

Risk of a dangerous situation causing serious physical injury.

**WARNING**

Risk of a dangerous situation causing slight physical injury.

**CAUTION**

Risk of material damage.



Signals important information.



Signals a referral to other instructions or other pages in the instructions.

## 1.2 Abbreviations

---

- ▶ **3CE**: Collective conduit for sealed boiler
- ▶ **Central heating**: Central heating
- ▶ **PCU**: Primary Control Unit - PCB for managing burner operation
- ▶ **SU**: Safety Unit - Safety PCB
- ▶ **PSU**: Parameter Storage Unit - Parameter storage for PCBs PCU and SU
- ▶ **SCU**: Secondary Control Unit - Extended control PCB

## 1.3 Liabilities

---

### 1.3.1. Manufacturer's liability

---

Our products are manufactured in compliance with the requirements of the various applicable European Directives. They are therefore delivered with  marking and all relevant documentation.

In the interest of customers, we are continuously endeavouring to make improvements in product quality. All the specifications stated in this document are therefore subject to change without notice.

Our liability as the manufacturer may not be invoked in the following cases:

- ▶ Failure to abide by the instructions on using the appliance.
- ▶ Faulty or insufficient maintenance of the appliance.
- ▶ Failure to abide by the instructions on installing the appliance.

### 1.3.2. Installer's liability

---

The installer is responsible for the installation and initial start up of the appliance. The installer must respect the following instructions:

- ▶ Read and follow the instructions given in the manuals provided with the appliance.
- ▶ Carry out installation in compliance with the prevailing legislation and standards.
- ▶ Perform the initial start up and carry out any checks necessary.
- ▶ Explain the installation to the user.
- ▶ If a maintenance is necessary, warn the user of the obligation to check the appliance and maintain it in good working order.
- ▶ Give all the instruction manuals to the user.

### 1.3.3. User's liability

---

To guarantee optimum operation of the appliance, the user must respect the following instructions:

- ▶ Read and follow the instructions given in the manuals provided with the appliance.
- ▶ Call on qualified professionals to carry out installation and initial start up.
- ▶ Get your installer to explain your installation to you.
- ▶ Have the required checks and services done by a qualified professional.
- ▶ Keep the instruction manuals in good condition close to the appliance.

This appliance is not intended to be used by persons (including children) whose physical, sensory or mental capacity is impaired or persons with no experience or knowledge, unless they have the benefit, through the intermediary of a person responsible for their safety, of supervision or prior instructions regarding use of the appliance. Care should be taken to ensure that children do not play with the appliance.

If the mains lead is damaged it must be replaced by the original manufacturer, the manufacturer's dealer or another suitably skilled person to prevent hazardous situations.

## 2 Safety instructions and recommendations

---

### 2.1 Safety instructions

---



#### DANGER

If you smell gas:

1. Do not use a naked flame, do not smoke, do not operate electrical contacts or switches ( doorbell, light, motor, lift, etc..).
2. Shut off the gas supply.
3. Open the windows.
4. Report any leaks immediately.
5. Trace possible leaks and seal them immediately.
6. If the gas leak is before the gas meter, contact the gas supplier.



#### DANGER

If you smell flue gases:

1. Switch the appliance off.
2. Open the windows.
3. Report any leaks immediately.
4. Trace possible leaks and seal them immediately.

### 2.2 Recommendations

---



#### WARNING

- ▶ Installation and maintenance of the boiler must be carried out by a qualified professional in compliance with prevailing local and national regulations.
- ▶ When working on the boiler, always disconnect the boiler from the mains and close the main gas inlet valve.
- ▶ After maintenance or repair work, check all installations to ensure that there are no leaks.



#### CAUTION

The boiler must be installed in a frost-free environment.



Store this document in the document wallet on the inside of the boiler casing (Underneath the instrument panel).

### **Casing components**

Only remove the casing for maintenance and repair operations. Put the casing back in place after maintenance and repair operations.

### **Instructions stickers**

The instructions and warnings affixed to the appliance must never be removed or covered and must remain legible during the entire lifespan of the appliance. Immediately replace damaged or illegible instructions and warning stickers.

### **Modifications**

Modifications may only be made to the boiler after the written permission of **Remeha** to do so.

# 3 Technical description

---

## 3.1 General description

---

### Floor-standing high efficiency gas boiler

- ▶ High efficiency heating.
- ▶ Low pollutant emissions.
- ▶ Heat exchanger made of cast aluminium sections.
- ▶ Transport wheels as standard.
- ▶ Left or right-hand version of the water and flue gas side connections possible.
- ▶ Separable for assembly in boiler room.
- ▶ **HMI Gas 310/610 ECO PRO** control panel.

### Boiler type:

- ▶ Type Gas 310 ECO PRO-285
- ▶ Type Gas 310 ECO PRO-355
- ▶ Type Gas 310 ECO PRO-430
- ▶ Type Gas 310 ECO PRO-500
- ▶ Type Gas 310 ECO PRO-575
- ▶ Type Gas 310 ECO PRO-650

### Boiler type:

- ▶ Type Gas 610 ECO PRO-570
- ▶ Type Gas 610 ECO PRO-710
- ▶ Type Gas 610 ECO PRO-860
- ▶ Type Gas 610 ECO PRO-1000
- ▶ Type Gas 610 ECO PRO-1150
- ▶ Type Gas 610 ECO PRO-1300

## 3.2 Homologations

---

### 3.2.1. Certifications

---

CE identification no	<b>PIN 0063CL3613</b>
NOx classification	<b>5 (EN 15420)</b>
Type of connection (Flue gas outlet)	B23, B23P, C33, C53, C63, C83, C93



### 3.3 Main parts

#### 3.3.1. Boiler type Gas 310 ECO PRO

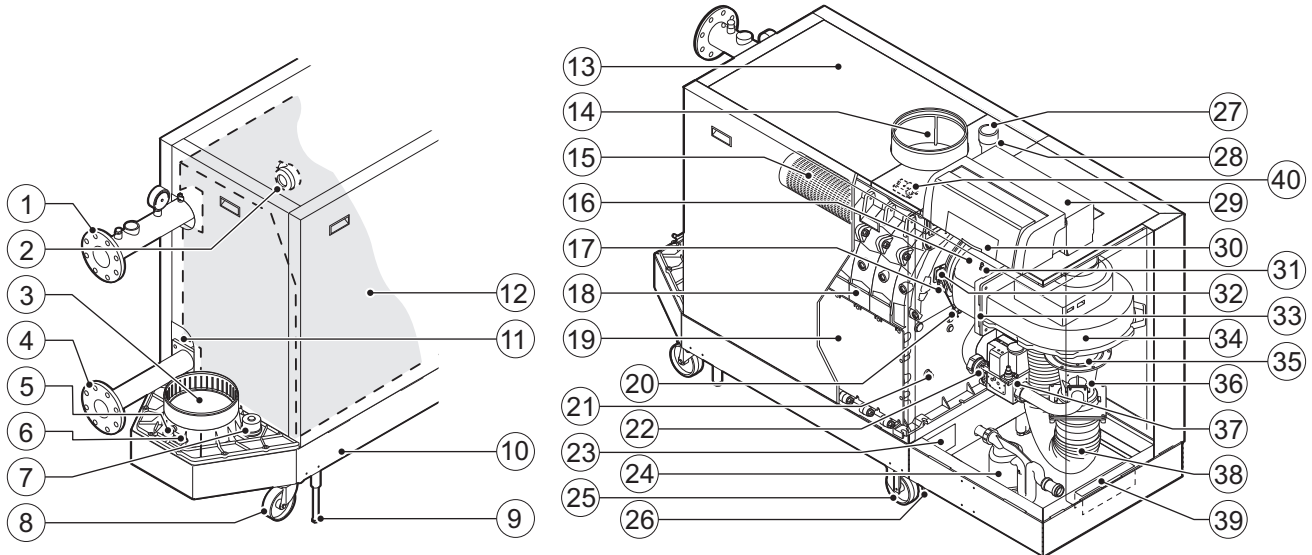

T004014-E

1	Flow connection <sup>(1)</sup>	21	Return sensor
2	Air differential pressure switch	22	Gas filter
3	Flue gas discharge pipe	23	Type plate
4	Return connection	24	Siphon
5	Outlet for measuring combustion gases	25	Transport wheels
6	Flue gas thermostat (Accessory)	26	Jacking bolt
7	Condensate collector sealant cap	27	Gas connection
8	Pivoting castor	28	Gas pressure measurement point
9	Jacking bolt	29	Control panel
10	Base frame	30	Location for optional features or a control unit
11	Second return connection (Accessory)	31	Pressure measurement point
12	Heat exchanger insulation kit (Accessory)	32	Sight glass
13	Boiler casing	33	Non-return valve
14	Air inlet	34	Fan
15	Burner	35	Extension piece
16	Adapter	36	Venturi
17	Ignition/ionization electrode	37	Gas block
18	Heat exchanger	38	Air inlet hose
19	Inspection hatch	39	Document holder
20	Heat exchanger sensor	40	Ignition transformer

(1) For more details about the devices in the flow pipe, please see "Connection of the heating circuit", page 28

### 3.3.2. Boiler type Gas 610 ECO PRO

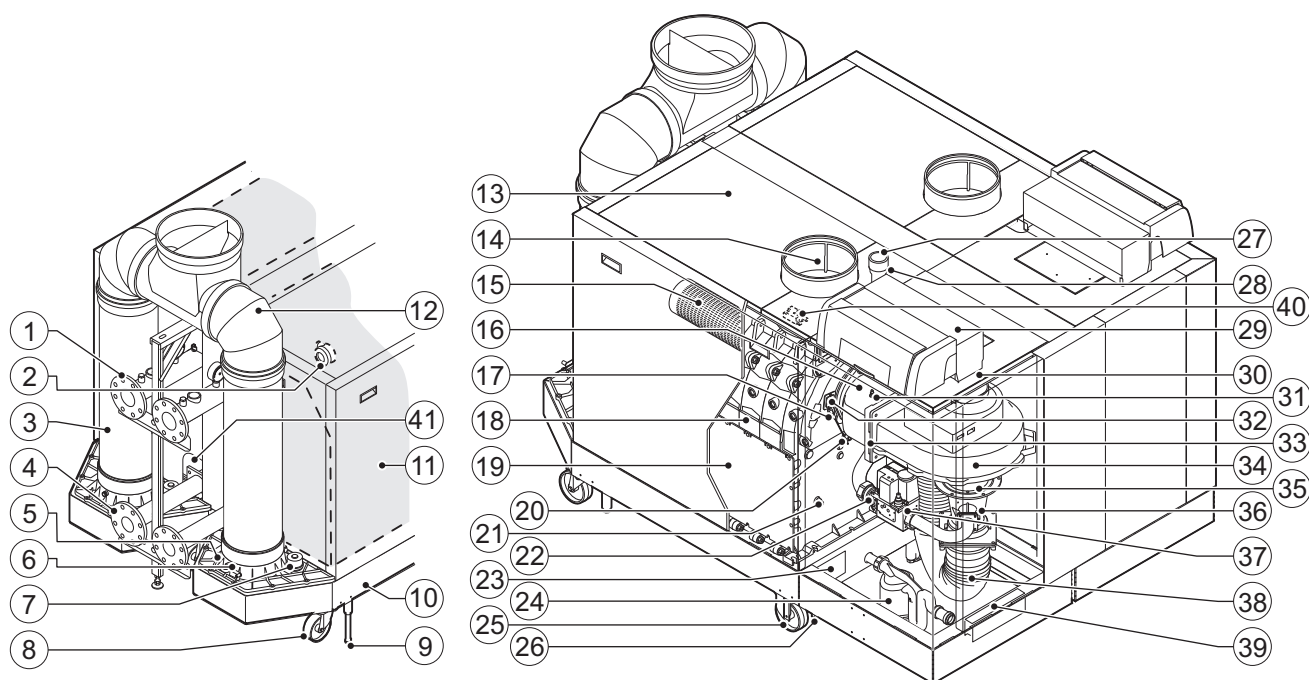

T004015-G

1	Flow connection <sup>(1)</sup>	21	Return sensor
2	Air differential pressure switch	22	Gas filter
3	Flue gas discharge pipe	23	Type plate
4	Return connection	24	Siphon
5	Outlet for measuring combustion gases	25	Transport wheels
6	Flue gas thermostat (Accessory)	26	Jacking bolt
7	Condensate collector sealant cap	27	Gas connection
8	Pivoting castor	28	Gas pressure measurement point
9	Jacking bolt	29	Control panel
10	Base frame	30	Location for optional features or a control unit
11	Heat exchanger insulation kit (Accessory)	31	Pressure measurement point
12	Flue gas collector	32	Sight glass
13	Boiler casing	33	Non-return valve
14	Air inlet	34	Fan
15	Burner	35	Extension piece
16	Adapter	36	Venturi
17	Ignition/ionization electrode	37	Gas block
18	Heat exchanger	38	Air inlet hose
19	Inspection hatch	39	Document holder
20	Heat exchanger sensor	40	Ignition transformer
		41	Second return connection (Accessory)

(1) For more details about the devices in the flow pipe, please see "Connection of the heating circuit", page 28

### 3.3.3. System pump

The boiler does not have a built-in pump. A system pump can be installed on the connector of the standard control PCB. This can be an on/off pump or a modulating pump (with 0 - 10 V control).

 For more information on controlling a modulating pump, See paragraph: "Electrical connections", page 36.

Parameters **P43** and **P44** are used to modify the pump settings.

 See the Installation and service manual **HMI GAS 310/610 ECO PRO** for comprehensive operating instructions. This includes information about changing and reading parameters, the meaning of fault codes and deleting the failure memory.

### 3.3.4. Regulation of the water temperature

---

The boiler is equipped with electronic temperature control based on flow, return, and boiler block temperature sensors. The flow temperature can be set between 20°C and 90°C. The boiler reduces its power when the set outlet-temperature is attained. The cutout temperature is the set heating outlet-temperature + 5 °C.

### 3.3.5. Protection against a shortage of water

---

The boiler is fitted with a safety device to prevent the shortage of water based on temperature measurements (Temperature difference between flow and return). If  $\Delta T = 25$  K is reached (factory setting), the boiler reduces its output by modulating to remain in operation as long as possible. If  $\Delta T \geq 25$  K the boiler goes into part load. If  $\Delta T > 25 + 5$  K the boiler goes into a normal control stop (blocking).

### 3.3.6. Maximum temperature protection

---

The maximum protection switches the boiler off if the water temperature is too high (110°C) and locks it on the control box (Fixed value, cannot be modified). Once the fault has been rectified, the boiler can be reset by pressing the **RESET** button for 2 seconds.

### 3.3.7. Air differential pressure switch

---

Before a start and when the boiler is in operation, the air pressure differential switch **PS** measures the difference in pressure between the measuring points at the rear of the heat exchanger **p<sup>+</sup>** and the air box **p<sup>-</sup>**. If the pressure difference is greater than 6 mbar, then the boiler will lock out. Once the fault has been rectified, the boiler can be reset by pressing the **RESET** button for 2 seconds.

## 3.4 Technical specifications

---

### 3.4.1. Boiler type Gas 310 ECO PRO

---

Boiler type	GAS 310 ECO PRO	Unit	285	355	430	500	575	650
<b>General</b>								
Number of sections	-	-	5	6	7	8	9	10
EC identification no.	PIN		0063CL3613					
Input control	Adjustable		Modulating, Start/Stop, 0 - 10 V					
Nominal output (Pn) (80/60 °C)	minimum maximum <sup>(1)</sup>	kW	51 261	65 327	79 395	92 461	106 530	119 601
Nominal output (Pn) (50/30 °C)	maximum <sup>(1)</sup>	kW	279	350	425	497	574	651
Nominal input(Qn) (Hs)	minimum maximum <sup>(1)</sup>	kW	60 295	75 369	96 445	105 520	121 598	135 677
Nominal input (Qn) (Hi)	minimum maximum <sup>(1)</sup>	kW	54 266	68 333	82 402	95 469	109 539	122 610
Full load water efficiency (Hi) (80/60 °C)		%	98.0	98.1	98.2	98.3	98.4	98.5
Full load water efficiency (Hi) (50/30 °C)		%	104.8	105.2	105.6	106.0	106.4	106.8
Low load water efficiency (Hi) (Tr = 60 °C)		%	94.7	95.3	95.8	96.3	96.8	97.3
Annual efficiency (DIN 4702, Part 8)		%	109.6	109.5	109.4	109.3	109.2	109.1
Part load efficiency 92/42 EEG (Tr = 30 °C)		%	109.2	109.0	108.8	108.6	108.3	108.1
<b>Data on the gases and combustion gases</b>								
Gas consumption G20 (Gas H)	minimum maximum	m <sup>3</sup> /h	5.7 28.1	7.2 35.2	8.7 42.5	10.1 49.6	11.5 57.0	12.9 64.6
Gas inlet pressure G20 (Gas H)	minimum maximum	mbar	17 30	17 30	17 100	17 100	17 100	17 30
Flue gas losses		%	2.3	2.3	2.3	2.3	2.3	2.3
NOx-Emission per year (BREEAM) (EN 15420)		mg/kWh	33	35	32	29	36	26
Maintenance consumption (EN15420) (Without heat exchanger insulation kit)	( $\Delta T = 30 K$ ) <sup>(2)</sup>	W %	571 0.21	591 0.18	611 0.15	630 0.13	650 0.12	670 0.11
Mass flue gas flow rate	minimum maximum	kg/h	91 448	114 560	138 676	160 789	183 907	205 1026
Flue gas temperature	minimum maximum	°C	30 80					
Maximum residual fan duty for flue gas		Pa	130	120	130	150	150	150
<b>Characteristics of the heating circuit</b>								
Water content	-	l	49	60	71	82	93	104
Water operating pressure	minimum	bar	0.8					
Water operating pressure (PMS)	maximum	bar	7					
Water temperature	maximum	°C	110					
Operating temperature	minimum	°C	20					
	maximum		90					
	Factory setting		80					
Water resistance ( $\Delta T = 20K$ )		mbar	113	110	120	110	125	130
		kPa	11.3	11	12	11	12.5	13.0
Water resistance ( $\Delta T = 11K$ )		mbar	374	364	397	364	413	435
		kPa	37.4	36.4	39.7	36.4	41.3	43.5
<b>Electrical characteristics</b>								
Power supply voltage		VAC/Hz	230/50					
Fuse (230 VAC)	F2 Circuit-breaker	AT	10					
	F1 control PCB	AT	2					
Power consumption - Full load	maximum	W	279	334	426	543	763	723
(1) Factory setting								
(2) $\Delta T$ = Boiler temp - Ambient temperature								
(3) For a room sealed operation								

Boiler type	GAS 310 ECO PRO	Unit	285	355	430	500	575	650
Power consumption - Part load	maximum	W	46	46	58	61	62	55
Power consumption - Standby	maximum	W	6	6	6	6	6	7
Electrical protection index		IP	X1B <sup>(3)</sup>					
<b>Other characteristics</b>								
Weight (empty)	Total	kg	364	398	433	495	531	568
Acoustic level at 1 metre <sup>(3)</sup>		dB(A)	61	61	65	65	65	65
Ambient temperature	maximum	°C	40					
(1) Factory setting								
(2) ΔT = Boiler temp - Ambient temperature								
(3) For a room sealed operation								

### 3.4.2. Boiler type Gas 610 ECO PRO

Boiler type	GAS 610 ECO PRO	Unit	570	710	860	1000	1150	1300
<b>General</b>								
Number of sections	-	-	2x5	2x6	2x7	2x8	2x9	2x10
EC identification no.	PIN		0063CL3613					
Input control	Adjustable		Modulating, Start/Stop, 0 - 10 V					
Nominal output (Pn) (80/60 °C)	minimum maximum <sup>(1)</sup>	kW	69 522	87 654	123 790	122 922	148 1060	158 1202
Nominal output (Pn) (50/30 °C)	maximum <sup>(1)</sup>	kW	558	700	850	994	1148	1303
Nominal input(Qn) (Hs)	minimum maximum <sup>(1)</sup>	kW	80 590	101 738	142 890	141 1040	170 1196	180 1354
Nominal input (Qn) (Hi)	minimum maximum <sup>(1)</sup>	kW	72 532	91 666	128 804	127 938	170 1078	162 1220
Full load water efficiency (Hi) (80/60 °C)		%	98.0	98.1	98.2	98.3	98.4	98.5
Full load water efficiency (Hi) (50/30 °C)		%	104.8	105.2	105.6	106.0	106.4	106.8
Low load water efficiency (Hi) (Tr = 60 °C)		%	94.7	95.3	95.8	96.3	96.8	97.3
Annual efficiency (DIN 4702, Part 8)		%	109.6	109.5	109.4	109.3	109.2	109.1
Part load efficiency 92/42 EEG (Tr = 30 °C)		%	109.2	109.0	108.8	108.6	108.3	108.1
<b>Data on the gases and combustion gases</b>								
Gas consumption G20 (Gas H)	minimum maximum	m <sup>3</sup> /h	7.6 56.2	9.6 70.4	13.5 85.0	13.4 99.2	16.2 114.0	17.2 129.2
Gas inlet pressure G20 (Gas H)	minimum maximum	mbar	17 30	17 30	17 100	17 100	17 100	17 30
Flue gas losses		%	2.3	2.3	2.3	2.3	2.3	2.3
NOx-Emission per year (BREEAM) (EN 15420)		mg/kWh	33	35	32	29	36	26
Maintenance consumption (EN15420) (Without heat exchanger insulation kit)	(ΔT = 30 K) <sup>(2)</sup>	W %	1142 0.21	1182 0.18	1222 0.15	1260 0.13	1300 0.12	1340 0.11
Mass flue gas flow rate	minimum maximum	kg/h	182 896	228 1120	276 1352	320 1578	366 1814	410 2052
Flue gas temperature	minimum maximum	°C	30 80					
Maximum residual fan duty for flue gas		Pa	130	120	130	130	130	150
<b>Characteristics of the heating circuit</b>								
(1) Factory setting								
(2) ΔT = Boiler temp - Ambient temperature								
(3) For a room sealed operation								

<b>Boiler type</b>	<b>GAS 610 ECO PRO</b>	<b>Unit</b>	<b>570</b>	<b>710</b>	<b>860</b>	<b>1000</b>	<b>1150</b>	<b>1300</b>
Water content	-	l	98	120	142	164	186	208
Water operating pressure	minimum	bar	0.8					
Water operating pressure (PMS)	maximum	bar	7					
Water temperature	maximum	°C	110					
Operating temperature	minimum	°C	20					
	maximum		90					
	Factory setting		80					
Water resistance ( $\Delta T = 20K$ )		mbar	113	110	120	110	125	130
		kPa	11.3	11	12	11	12.5	13
Water resistance ( $\Delta T = 11K$ )		mbar	374	364	397	364	413	435
		kPa	37.4	36.4	39.7	36.4	41.3	43.5
<b>Electrical characteristics</b>								
Power supply voltage		VAC/Hz	230/50					
Fuse (230 VAC)	F2 Circuit-breaker	AT	10					
	F1 control PCB	AT	2					
Power consumption - Full load	maximum	W	558	668	852	1086	1526	1446
Power consumption - Part load	maximum	W	92	92	116	122	124	110
Power consumption - Standby	maximum	W	12	12	12	12	12	14
Electrical protection index		IP	X1B <sup>(3)</sup>					
<b>Other characteristics</b>								
Weight (empty)	Total	kg	707	771	837	957	1025	1095
Acoustic level at 1 metre <sup>(3)</sup>		dB(A)	64	64	68	68	68	68
Ambient temperature	maximum	°C	40					
(1) Factory setting								
(2) $\Delta T$ = Boiler temp - Ambient temperature								
(3) For a room sealed operation								

# 4 Installation

## 4.1 Regulations governing installation



### WARNING

Installation of the appliance must be done by a qualified engineer in accordance with prevailing local and national regulations. The engineer must be Gas Safe registered and have the correct ACS qualifications.

## 4.2 Package list

### 4.2.1. Standard delivery

- ▶ The boiler
- ▶ Complete siphon
- ▶ Filling and drainage valve
- ▶ Gas filter
- ▶ Installation, User and Service Manual
- ▶ Water quality instructions

### 4.2.2. Accessories



Only use the original or recommended accessories.

Description	
Modulating cascade controller <b>iSense Pro</b>	Gas valve leak proving system VPS
Modulating cascade controller <b>Celcia MC4</b>	Safety pressure sensitive switch
<b>C-mix</b> regulator	Condensates neutralisation station
Modulating controller <b>iSense</b>	Air supply collector (For a room sealed operation)
Outside temperature sensor (AF 60)	Combined roof outlet 200/300 mm
Circulating pump replacement pipe	Combined roof outlet 250/350 mm
Second return connection	Parallel roof feed-through 350 mm
Heat exchanger insulation kit	Air supply filter
Exchanger cleaning tool (length 560 mm)	Combustion air/flue gas adapter 250 - 200 mm
Gas main cock	Combustion air/flue gas adapter Gas 310 ECO - Gas 310 ECO PRO
<b>Recom</b> communication kit	Flue gas collector(250/350 mm) (base frame included)
Flue gas thermostat (Switch temperature 110°C)	Air supply filter box for closed configuration
Pressure switch minimum GPS	

### 4.3 Installation options

#### 4.3.1. Transport

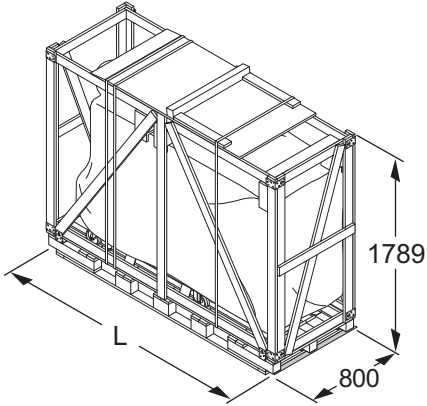

T003980-C



For **Gas 610 ECO PRO** boilers: The features and instructions described are for each boiler module.

Boiler type Gas 310 ECO PRO	L (mm)
285	1920
355	
430	
500	2230
575	
650	

The boiler is supplied fully assembled on a pallet. See the diagram and table for the dimensions. The base of the packaging is a pallet 80 cm wide. This means that the crate can be transported with a pallet truck or four-wheel transport boards. Without the packaging, the boiler is 720 mm wide (700 mm without casing) and the boiler will fit through standard doors. The boiler has integrated wheels, so that it can easily be moved around once the packaging has been removed.



**CAUTION**

The wheels are designed for transport purposes only and not for use when the boiler is in its final position.

If required for internal transport, the boiler can be dismantled into smaller parts for transport. The boiler can be stripped of:

- ▶ Casing components
- ▶ Gas/air components
- ▶ The frame section on the instrument panel side

See the diagram and table for the dimensions of the largest remaining transport part (Frame section with heat exchanger and water connections).

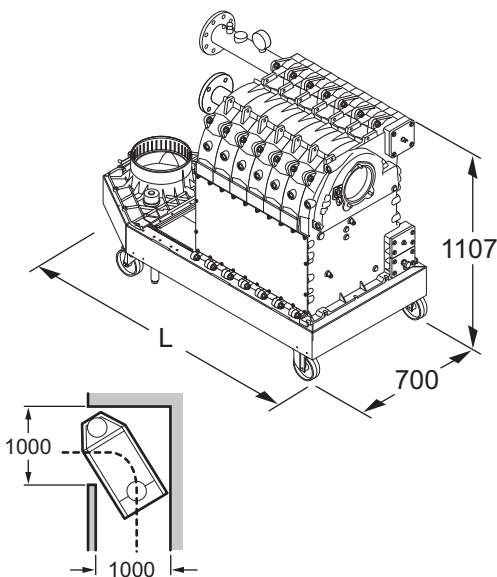

T003676-B

Boiler type Gas 310 ECO PRO	Weight (kg)	L (mm)
285	249	1160
355	283	
430	317	
500	356	1469
575	390	
650	424	



For information on fitting the parts, refer to the assembly instructions delivered with the boiler.

### 4.3.2. Location of the boiler

#### ■ Boiler type Gas 310 ECO PRO

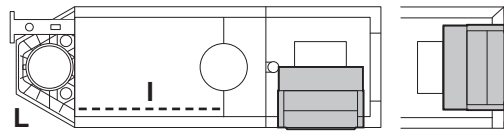

- L** Left version
- R** Right version
- I** Inspection hatch (Service side)

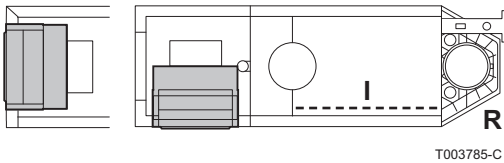

T003785-C

The service side with the inspection hatch on the heat exchanger is considered to be the front of the boiler. The boiler is available in both a 'left-hand' and 'right-hand' version. This means that the hydraulic connections and the flue gas discharge are situated on either the left or the right-hand side of the boiler. The control panel is on the front as standard, but can easily be rotated so that it is on the short side.

To make the boiler level and to raise the wheels off the floor, the adjustment bolts must be used. Turn the adjustment bolts out as soon as the boiler is placed in the correct position. The picture shows the support surface of the boiler (This is the position of the adjustment bolts).

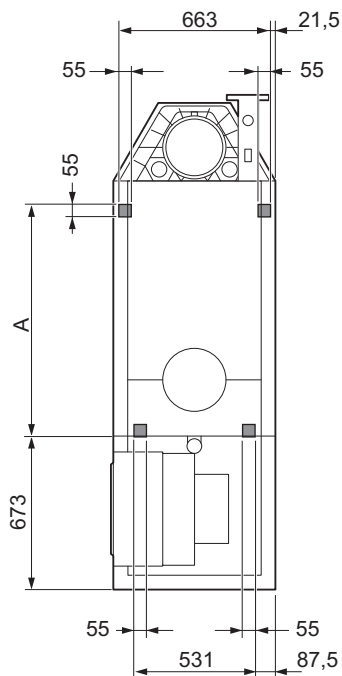

T003474-B

Boiler type Gas 310 ECO PRO	A (mm)
285	723
355	
430	
500	1032
575	
650	

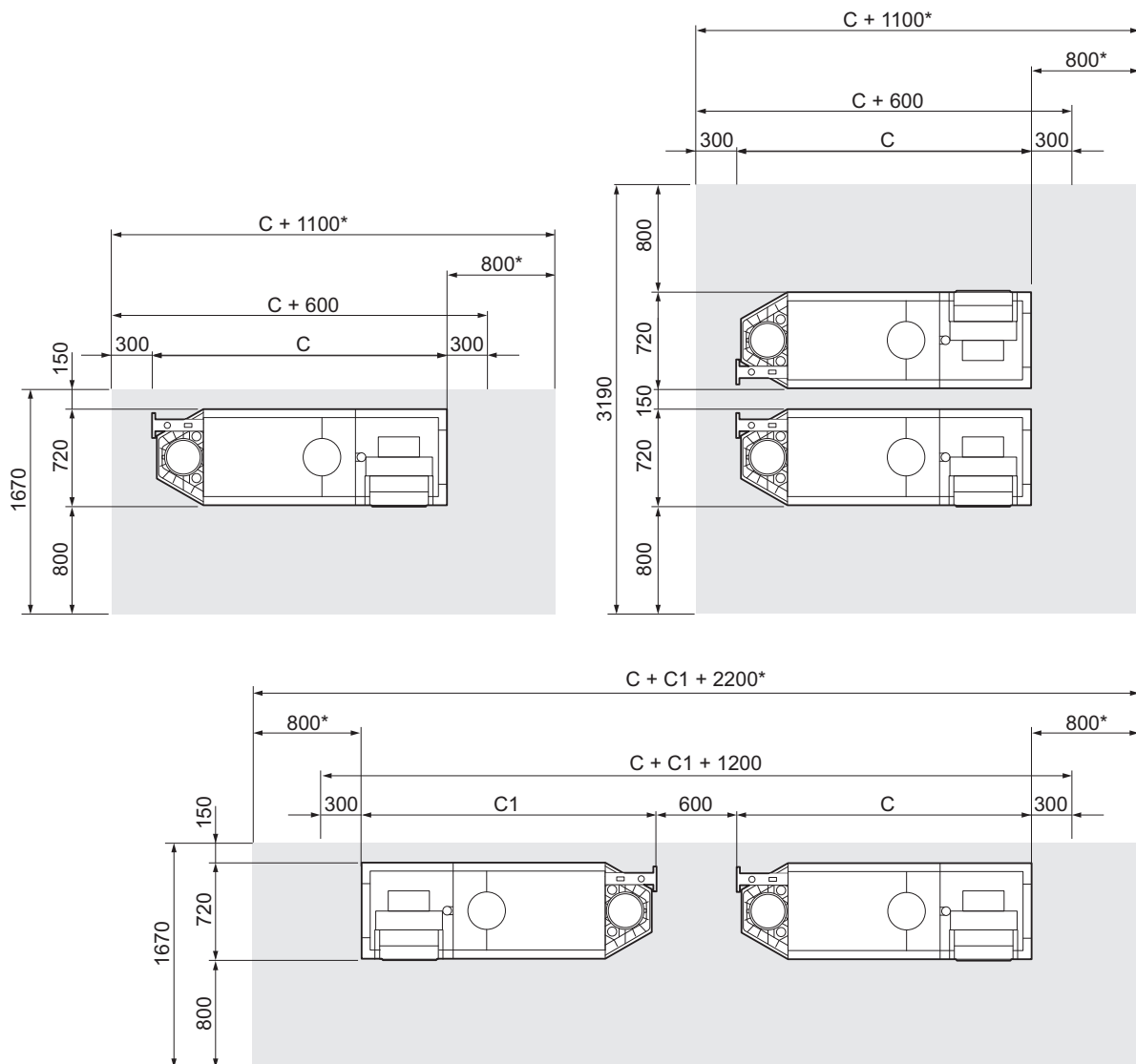

T003499-C

\* = Spacing required if this is operating side.

 For the dimensions of C/C1, see paragraph: "Main dimensions", page 26

A technical clearance of at least 80 cm is required at the front (service side) of the boiler. However, we recommend that the clearance is at least 100 cm. We recommend a clearance of at least 40 cm above the boiler (If the air supply filter is used, there must be a clearance of at least 65 cm). A minimum of 30 cm is required on the side of the flue gas discharge, and a minimum of 30 cm is also required on the other side (or 80 cm, if this is operating side).

■ **Boiler type Gas 610 ECO PRO**

The boiler is not available with a choice between 'left-hand' and 'right-hand' versions. The control panel is on the front as standard, but can easily be rotated so that it is on the short side.

To make the boiler level and to raise the wheels off the floor, the adjustment bolts must be used. Turn the adjustment bolts out as soon as the boiler is placed in the correct position. The picture shows the support surface of the boiler (This is the position of the adjustment bolts).

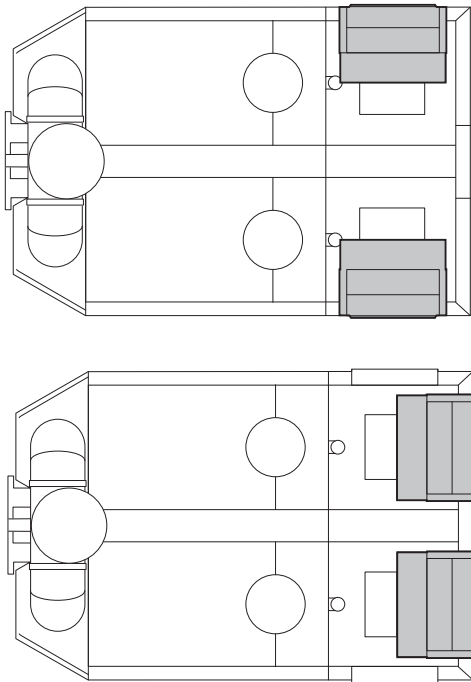

T003784-C

Boiler type	A (mm)
Gas 610 ECO PRO	
570	723
710	
860	
1000	1032
1150	
1300	

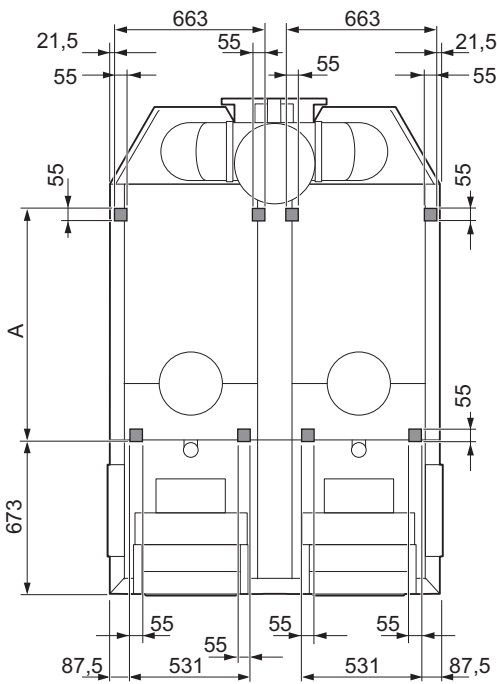

T003767-D

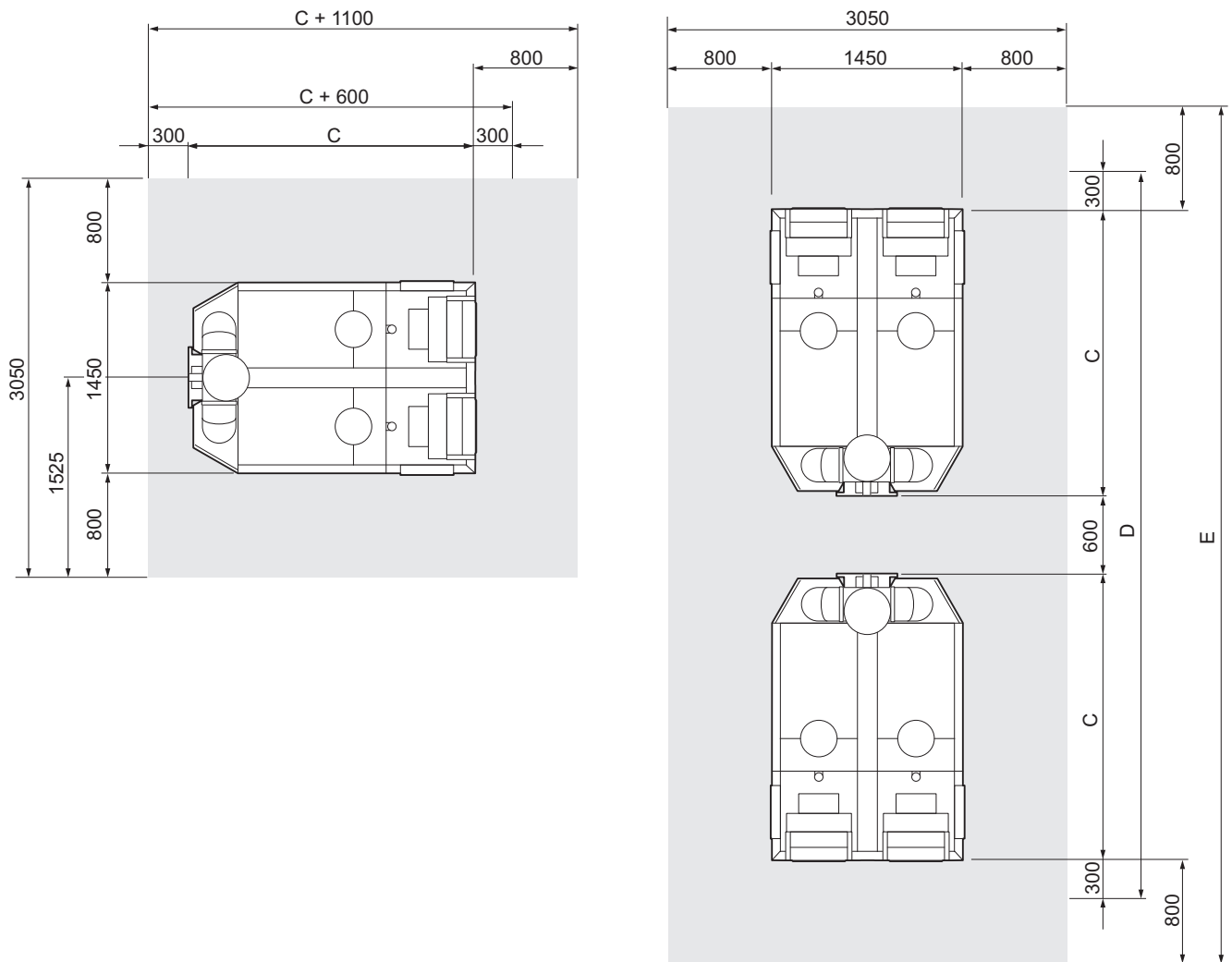

T003768-F

 For the dimensions of C, see paragraph: "Main dimensions", page 26.

A technical clearance of at least 80 cm is required at the front (service side) of the boiler. However, we recommend that the clearance is at least 100 cm. We recommend a clearance of at least 40 cm above the boiler (If the air supply filter is used, there must be a clearance of at least 65 cm). A minimum of 30 cm is required on the side of the flue gas discharge, and a minimum of 30 cm is also required on the other side (or 80 cm, if this is operating side).

### ■ Rotate instrument panel

The control panel is on the front as standard, but can easily be rotated so that it is on the short side.

1. Unscrew the 4 lateral holding screws in the control panel.
2. Remove the protective cover.
3. Unscrew the 2 bottom plate screws.
4. Lift up the instrument panel with the bottom plate.
5. Turn the instrument panel and the bottom plate into position on the short side.
6. Slide the lips of the bottom plate into the appropriate slots.
7. Tighten the 2 bottom plate screws.
8. Refit the protective cover.
9. Screw the 4 lateral holding screws back in.

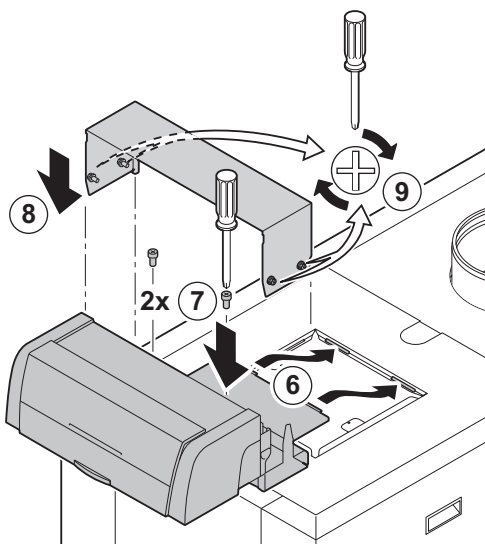
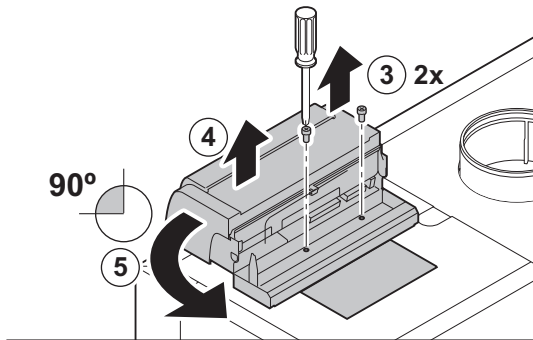
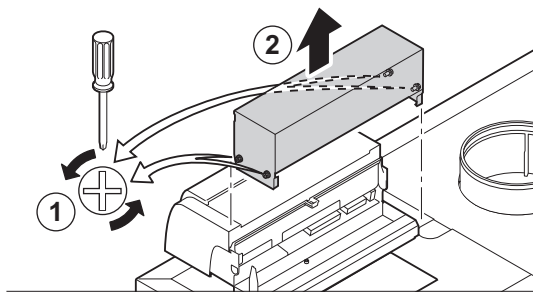

T004028-E

### 4.3.3. Main dimensions

#### ■ Boiler type Gas 310 ECO PRO

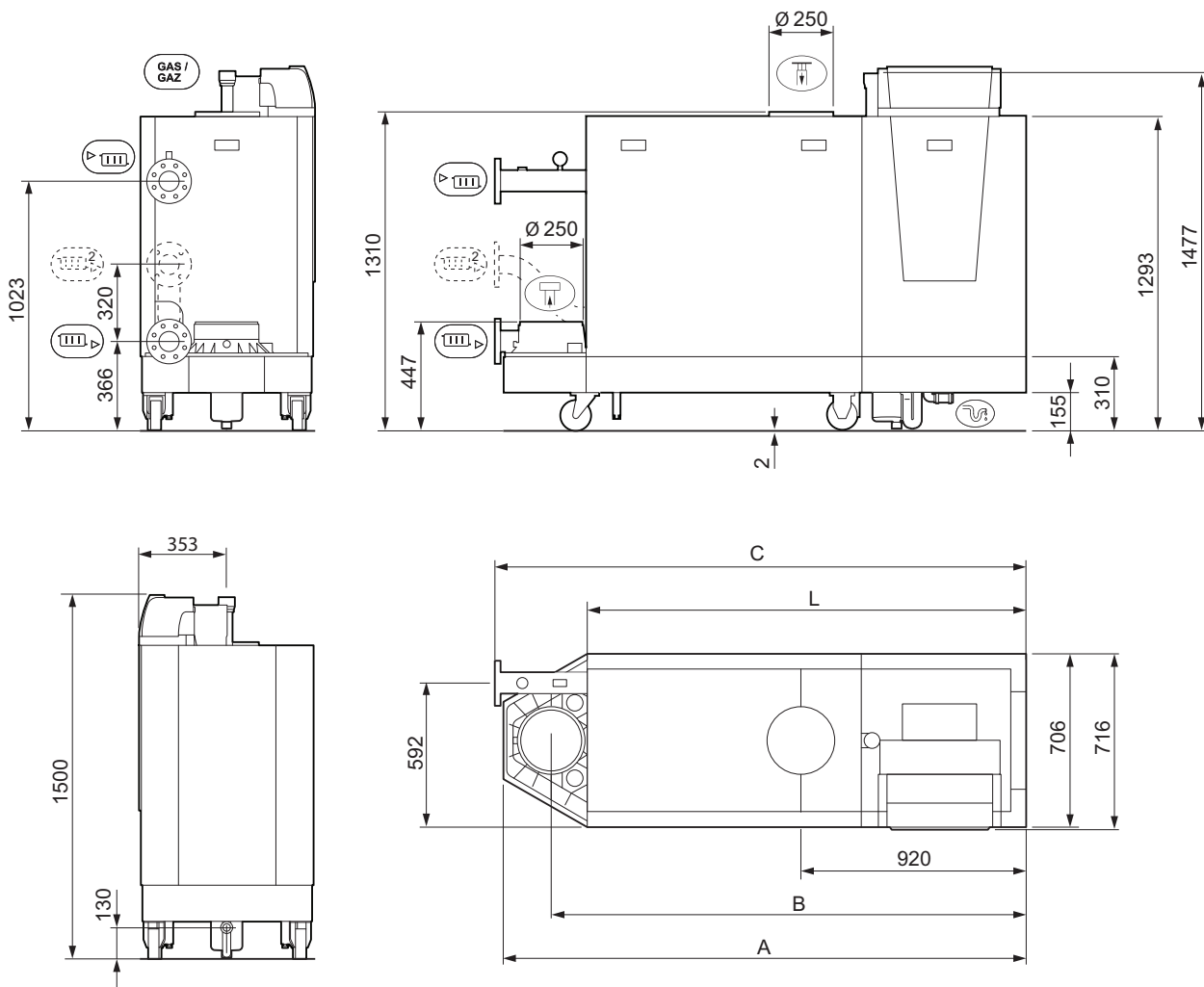

T003472-H

Gas 310 ECO PRO	A (mm)	B (mm)	C (mm)	L (mm)	Symbol	Fittings
285	1833	1635	1862	1490		Heating circuit flow, Flange NW 80 (DIN 2576)
355	1833	1635	1862	1490		Heating circuit return, Flange NW 80 (DIN 2576)
430	1833	1635	1862	1490	Gas / Gaz	Gas connection, G2" (Female thread)
500	2142	1944	2172	1800		Condensates discharge, Ø 32 mm (Internal) Condensates discharge, 1/4" (Internal)
575	2142	1944	2172	1800		Flue gas discharge pipe, Ø 250 mm
650	2142	1944	2172	1800		Air intake, Ø 250 mm
						Second return (optional), Flange NW 65 (DIN 2576))

■ Boiler type Gas 610 ECO PRO

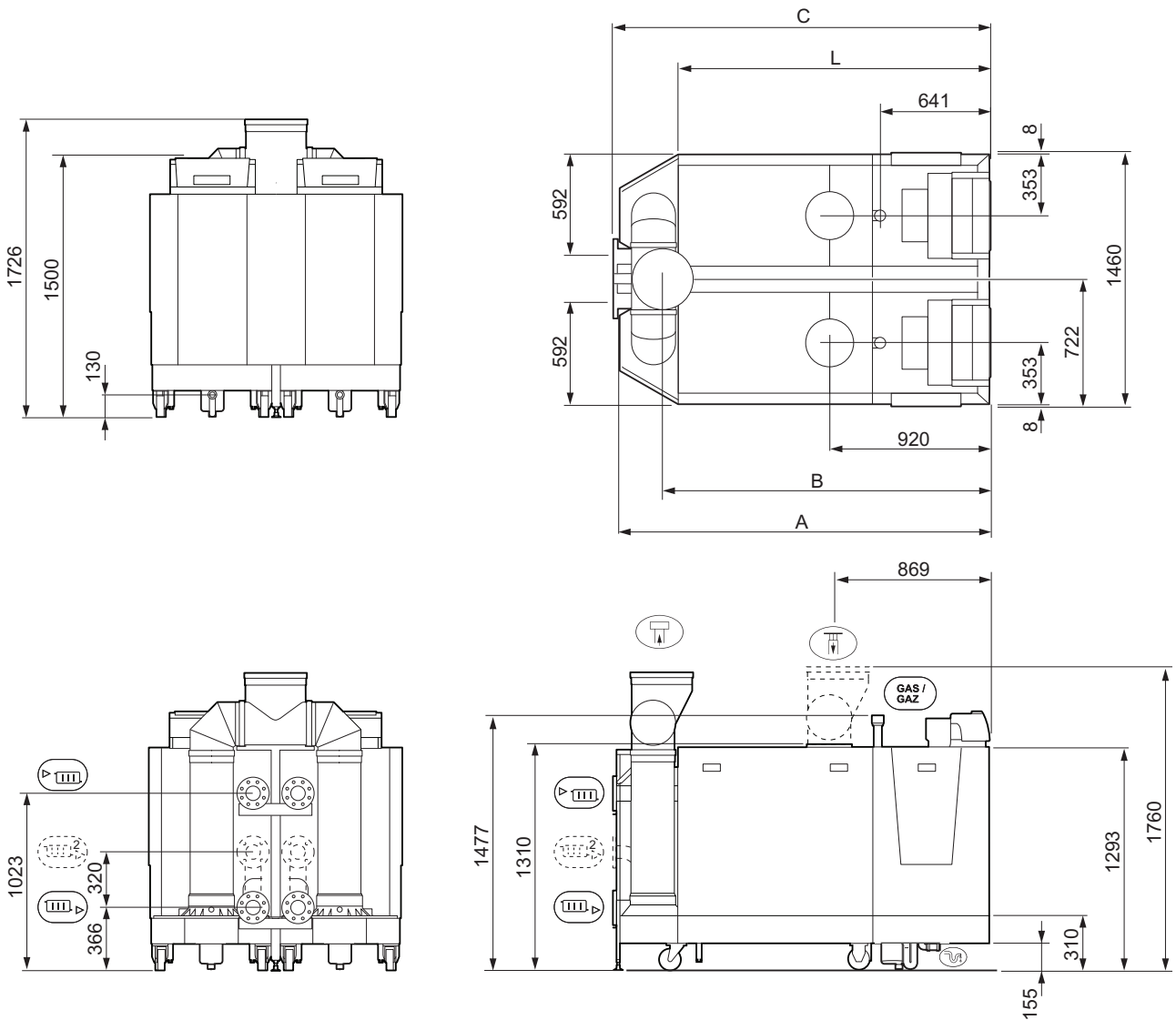

T003766-J

Gas 610 ECO PRO	A (mm)	B (mm)	C (mm)	L (mm)	Symbol	Fittings
570	1833	1582	1862	1490		Heating circuit flow, Flange NW 80 (DIN 2576)
710	1833	1582	1862	1490		Heating circuit return, Flange NW 80 (DIN 2576)
860	1833	1582	1862	1490		Gas / Gaz connection, G2" (Female thread)
1000	2142	1892	2172	1800		Condensates discharge, Ø 32 mm (Internal) Condensates discharge, 1¼" (Internal)
1150	2142	1892	2172	1800		Flue gas discharge pipe, Ø 350 mm
1300	2142	1892	2172	1800		Air intake, Ø 250 mm Air supply collector (Option), Ø 350 mm
						Second return (optional), Flange NW 65 (DIN 2576)

## 4.4 Hydraulic connections

### 4.4.1. Flushing the system

The installation must be cleaned and flushed according to BS 7593 (2006).

#### Installing the boiler in new installations (installations less than 6 months old)

- ▶ Clean the installation with a universal cleaner to eliminate debris from the system (copper, hemp, flux).
- ▶ Thoroughly flush the installation until the water runs clear and shows no impurities.

#### Installing the boiler in existing installations

- ▶ Remove sludge from the installation.
- ▶ Flush the installation.
- ▶ Clean the installation with a universal cleaner to eliminate debris from the system (copper, hemp, flux).
- ▶ Thoroughly flush the installation until the water runs clear and shows no impurities.



Suitable chemicals and their use should be discussed with specialist water treatment companies in respect to aluminium heat exchangers.

### 4.4.2. Connection of the heating circuit







For the connection(s) of the boiler **Gas 610 ECO PRO**: The features and instructions described are for each boiler module.



#### CAUTION

The heating pipe must be mounted in accordance with prevailing provisions.

1. Remove the dust cap on the central heating flow connection .
2. Remove the dust cap on the central heating return connection .
3. Connect the heating water outlet pipe to the connection .
4. Connect the heating water return pipe to the connection .
5. Connect a safety valve to the boiler's flow connection.
6. Connect the pump to the boiler's return connection.

Always connect the boiler in a way that will guarantee the water flow through the unit during operation. When the boiler is used in a system with two return pipes, the return pipe must be used as a lowest temperature return. The second return pipe (accessory) is then used as a higher temperature return. Refer to the instructions supplied with the product. Please contact us for further information.

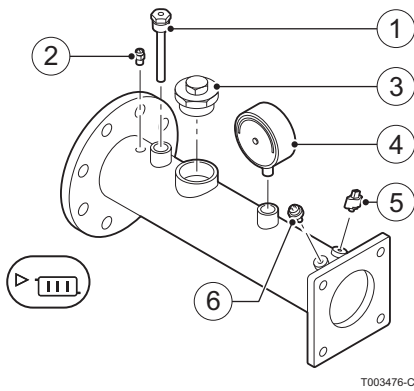

**The flow pipe is fitted with the following components:**

- 1 Tube pocket for a temperature sensor for an external control (1/2").
- 2 Vent device (1/8").
- 3 Connection for safety valve (1 1/2").
- 4 Pressure gauge (1/2").
- 5 Flow sensor (M6).
- 6 High-limit thermostat (M4).

**4.4.3. Connecting the condensate discharge pipe**

**i** For the connection(s) of the boiler **Gas 610 ECO PRO**: The features and instructions described are for each boiler module.

Discharge the condensed water directly into the drain using a syphon. In view of the acidity level (pH 2 to 5), only use plastic material for the discharge pipe.

1. Install a plastic drain pipe on the syphon (dia. 32 mm or larger, connected to a drain).



**CAUTION**

Do not make a fixed connection in order to prevent an overpressure in the syphon.



- ▶ The condensate drain must be connected openly to the drain.
- ▶ Set the discharge pipe at a gradient of at least 5 - 10 mm per metre, maximum horizontal length 5 metres.
- ▶ Do not drain condensation water into a roof gutter at any time.
- ▶ Connect the condensate discharge pipe in accordance with prevailing standards.

## 4.5 Gas connection



For the connection(s) of the boiler **Gas 610 ECO PRO**: The features and instructions described are for each boiler module.



### WARNING

- ▶ Close the main gas valve before starting work on the gas pipes.
- ▶ Also fit a gas cock near the boiler.
- ▶ Eliminate debris and dust from the gas pipes.



The boiler is fitted with a gas filter as standard.

1. Remove the dust cap on the gas connection .
2. Connect the gas inlet pipe (Please refer to local rules).

## 4.6 Connections for the air and exhaust pipes



The boiler is suitable for the following types of flue gas connections. See chapter: "Certifications", page 11.

Follow applicable local guidelines when connecting the flue gas discharge and air supply pipes to the boiler. The diameters of the pipes must be defined in accordance with the standards in force in your country. The total resistance of the flue gas discharge and air supply must not exceed the maximum acceptable resistance.



To determine the maximum length of the air pipes and flue gas pipes. See chapter: "Lengths of the air/flue gas pipes", page 32.



With room sealed operation, make sure the dirt trap in the boiler air supply remains accessible. For example, fit a T piece with an inspection hatch in the air supply pipe directly above the boiler.



With a flue gas connection of two or more **Gas 310 ECO PRO** boilers, certain fan speeds need to be changed. Change the values of parameters **P18**, **P19** and **P20** for each boiler in the flue gas connection. Set them to the values as specified in the parameter table for the **Gas 610 ECO PRO** boiler.



See the Installation and service manual **HMI GAS 310/610 ECO PRO** for comprehensive operating instructions. This includes information about changing and reading parameters, the meaning of fault codes and deleting the failure memory.

### 4.6.1. Classification

The table specifies this classification in detail according to **CE**.

Type	Execution	Description
B23 B23P <sup>(1)</sup>	Open flue	<ul style="list-style-type: none"> <li>▶ Without fire-stop approval.</li> <li>▶ Exhaust of combustion gases above the roof.</li> <li>▶ Air in the installation room.</li> </ul>
B33	Open flue	<ul style="list-style-type: none"> <li>▶ Without fire-stop approval.</li> <li>▶ Common exhaust of combustion gases above the roof.</li> <li>▶ Common exhaust of combustion gases mixed in the air, air in the installation room (special construction).</li> </ul>
C33	Room sealed flue	<ul style="list-style-type: none"> <li>▶ Exhaust of combustion gases above the roof.</li> <li>▶ The opening for the air-supply inlet is located in the same pressure zone as the vent (For example, a concentric passage to the roof).</li> </ul>
C53	Room sealed flue	<ul style="list-style-type: none"> <li>▶ Closed equipment.</li> <li>▶ Separate channelling for the air-supply.</li> <li>▶ Separate channelling for the combustion gases.</li> <li>▶ Air-supply inlet and flue gas outlet are located in different pressure zones.</li> </ul>
C63	Room sealed flue	<ul style="list-style-type: none"> <li>▶ The manufacturer delivers this type of equipment without a supply or exhaust system.</li> </ul>
C83 <sup>(2)</sup>	Room sealed flue	<ul style="list-style-type: none"> <li>▶ The equipment can be connected on a so-called semi-CLV system (with common combustion gas exhaust).</li> </ul>
C93 <sup>(3)</sup>	Room sealed flue	<ul style="list-style-type: none"> <li>▶ Channel for the air-supply and exhaust fumes in a duct or surrounded by a sleeve:                             <ul style="list-style-type: none"> <li>– Concentric.</li> <li>– Eccentric; Air supply from the shaft.</li> <li>– Exhaust of combustion gases above the roof.</li> <li>– The opening for the air-supply inlet is located in the same pressure zone as the vent.</li> </ul> </li> </ul>
<p>(1) Including the pressure classification P1                      (2) An under pressure of 4 mbar is possible                      (3) Ask your supplier for minimum dimensions of duct or sleeve</p>		

### 4.6.2. Outlets

The boilers can be used in room-ventilated or room-sealed operation. The air supply connection kit must be used for closed configurations (This is available as an accessory).

When exhausting combustion gases of type C6, the material of the exhaust must conform with Gastec QA and/or be provided with CE marking.

The flue gas pipes must be calculated conforming to EN 13384 (parts 1 & 2).



For open exhaust of combustion gases above the roof, the vent must always be provided with a suitable stainless steel wire grill.

### 4.6.3. Lengths of the air/flue gas pipes



- ▶ To define the maximum final length, you must deduct the pipe length in accordance with the reduction table.
- ▶ The boiler is also suitable for longer chimney lengths with diameters other than those indicated in the table. Please contact us for further information.

#### ■ Open flue (B23, B23P)

"If using an open flue version, the air supply opening remains open; only the combustion gas opening is connected". The boiler then takes in the combustion air required directly from the premises in which it is installed. For the application of air discharge and combustion gas discharge piping with a diameter other than 250 mm, a reducer should be used.



#### CAUTION

- ▶ If the boiler, in room ventilated operation, has been set up in a (very) dusty room, use the air supply filter (Accessory).
- ▶ Use of the air supply filter is compulsory when the boiler is exposed to building dust.



#### CAUTION

- ▶ The air supply opening must remain open.
- ▶ The premises in which the appliance is installed must be fitted with the necessary air supply openings. They must not be reduced or closed.

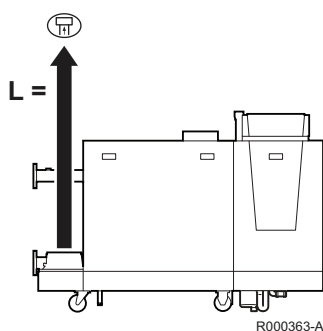

Gas 310 ECO PRO	Chimney length for the open flue version			
	Maximum length (L) <sup>(1)</sup>			
Boiler type	with a Ø of 150 mm	with a Ø of 180 mm	with a Ø of 200 mm	with a Ø of 250 mm
285	20 m	50 m	50 m	50 m
355	11 m	30 m	50 m	50 m
430	8 m	22 m	39 m	50 m
500	7 m	18 m	32 m	50 m
575	5 m	13 m	24 m	50 m
650	5 m	12 m	21 m	50 m

(1) Calculated with rigid pipe and Outlet without hood (open 'free')

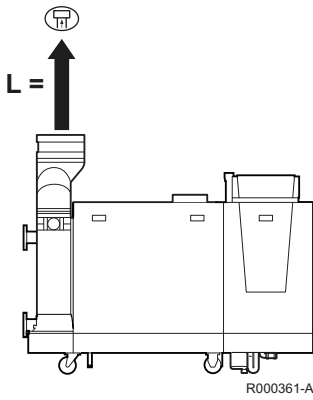

Gas 610 ECO PRO	Chimney length for the open flue version		
Boiler type	Maximum length (L) <sup>(1)</sup>		
	with a Ø of 250 mm	with a Ø of 300 mm	with a Ø of 350 mm
570	50 m	50 m	50 m
710	31 m	50 m	50 m
860	20 m	50 m	50 m
1000	11 m	39 m	50 m
1150	5 m	26 m	50 m
1300	3 m	19 m	50 m

(1) Calculated with rigid pipe and Outlet without hood (open 'free')

■ Room sealed flue (C33, C63, C93)

If using a room sealed version, it is necessary to connect both the combustion gas exhaust and the air-supply opening (parallel). For the application of air discharge and combustion gas discharge piping with a diameter other than 250 mm, a reducer should be used.

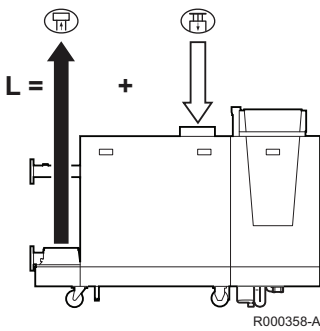

Gas 310 ECO PRO	Chimney length for room sealed operation		
Boiler type	Maximum length (L) <sup>(1)</sup>		
	with a Ø of 200 mm	with a Ø of 250 mm	with a Ø of 300 mm
285	42 m	50 m	50 m
355	21 m	50 m	50 m
430	13 m	50 m	50 m
500	10 m	50 m	50 m
575	5 m	34 m	50 m
650	4 m	30 m	50 m

(1) Calculated with rigid pipe and Outlet without hood (open 'free')

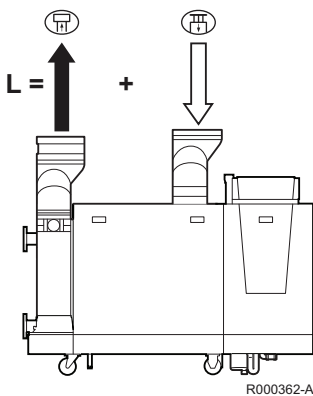

Gas 610 ECO PRO	Chimney length for room sealed operation		
Boiler type	Maximum length (L) <sup>(1)</sup>		
	with a Ø of 300 mm	with a Ø of 350 mm	with a Ø of 400 mm
570	50 m	50 m	50 m
710	43 m	50 m	50 m
860	26 m	50 m	50 m
1000	13 m	35 m	50 m
1150	5 m	16 m	24 m
1300	-	10 m	12 m

(1) Calculated with rigid pipe and Parallel roof feed-through 350 mm (Accessory)

■ **Connection in areas of different pressure ( C53, C83)**

Combustion air supply and combustion gas discharge are possible in various pressure zones, semi-CLV systems. The maximum permissible difference in height between the combustion air supply and the combustion gas discharge is 36 m.

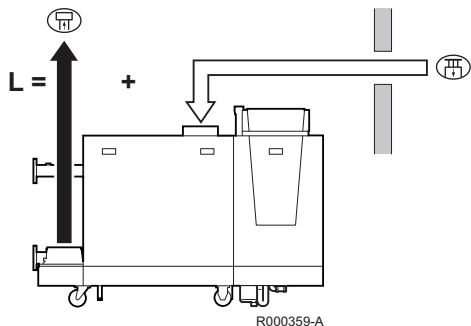

Gas 310 ECO PRO		Chimney length in the various pressure zones	
Boiler type	Maximum length (L) <sup>(1)</sup>		
	with a Ø of 250 mm		
285	50 m		
355	50 m		
430	50 m		
500	50 m		
575	49 m		
650	40 m		

(1) Calculated with rigid pipe and Elbow 90° and Outlet without hood (open 'free')

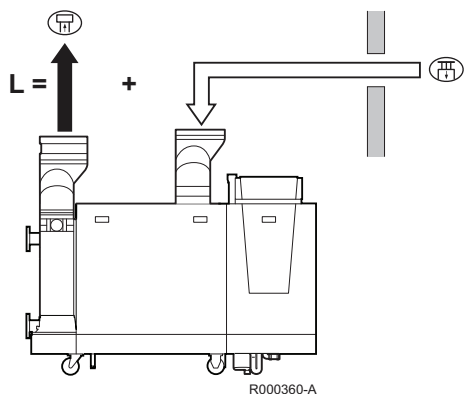

Gas 610 ECO PRO		Chimney length in the various pressure zones	
Boiler type	Maximum length (L) <sup>(1)</sup>		
	with a Ø of 350 mm	with a Ø of 400 mm	
570	50 m	50 m	
710	50 m	50 m	
860	50 m	50 m	
1000	33 m	50 m	
1150	-	22 m	
1300	-	-	

(1) Calculated with rigid pipe and Elbow 90° and Outlet without hood (open 'free')

■ **Reduction table**

Pipe reductions per element used		
Diameter	Elbow 45°	Elbow 90°
	Pipe reduction	Pipe reduction
150 mm	1,2 m	2,1 m
180 mm	1,4 m	2,5 m
200 mm	1,6 m	2,8 m
250 mm	2,0 m	3,5 m
300 mm	2,4 m	4,2 m
350 mm	2,8 m	4,9 m
400 mm	3,2 m	5,6 m

#### 4.6.4. Additional Directives

---

- ▶ Please refer to the manufacturer's instructions for the material in question when installing the flue gas discharge and air supply materials. If the flue gas discharge and air supply materials are not installed according to the instructions (e.g. they are not leakproof, not clamped in place etc.), this may cause hazardous situations and/or result in bodily injury. After assembly, check at least all flue gas and air-carrying parts for tightness.
- ▶ Connection of the combustion gas exhaust directly to the buildings brick chimneys or flues is forbidden for condensation reasons.
- ▶ Always clean the ducts thoroughly in cases where lining pipes are used and/or a connection of the air-supply.
- ▶ It must be possible to inspect the flue or chimney.
- ▶ In cases where condensate coming from the stainless steel or plastic sections of the flue gas pipe can be driven back towards the aluminium section, this condensate must be removed using a collecting device before the aluminium section is reached.
- ▶ For long, aluminium, combustion-gas exhaust pipes it is initially necessary to consider the relatively high quantity of corrosive products which are brought together with the condensate from the exhaust pipe. The siphon on the equipment requires regular cleaning or, preferably, an additional condensate collector can be installed above the equipment.
- ▶ The combusted gas discharge pipe must be sufficiently inclined towards the boiler (at least 50 mm per metre) and an adequate condensate collection tank and discharge system constructed (at least 1 m before the boiler opening). The elbows fitted must be at more than 90° to guarantee the provision of an adequate gradient and tightness on the lip rings.



Please contact us for further information.

#### 4.6.5. Connection of the combustion gas exhaust pipe

---

The boiler is equipped with a mechanical flue gas non-return valve as standard. This prevents flue gas travelling back up into the boiler when it is not in operation. (E.g. for cascade systems).

##### Mounting

1. Fit the combustion product discharge conduit.

## 2. Fit together the combustion gas exhaust pipes, without welding.



- ▶ The pipes must allow no leakage of flue gases and be resistant to corrosion.
- ▶ Connect the pipes together without stress between the sections.
- ▶ Maximum bracket distance from vertical pipes is 2 m.
- ▶ Maximum tilt of vertical pipes is 20 mm/m.
- ▶ The pipes must not rest on the boiler or flue gas adapter.
- ▶ The horizontal sections need to be constructed with a gradient of 50 mm per metre: Back to the boiler.
- ▶ Use a bracket at each connection from horizontal pipes.

**4.6.6. Connection of the air intake pipe****Mounting**

1. Fit the air-intake conduit.
2. Fit the air-intake conduits together without welding.



- ▶ The pipes must be airtight and corrosion-resistant.
- ▶ Connect the pipes together without stress between the sections.
- ▶ Maximum bracket distance from vertical pipes is 2 m.
- ▶ Maximum tilt of vertical pipes is 20 mm/m.
- ▶ The pipes must not rest on the boiler or air supply adapter.
- ▶ The horizontal sections need to be constructed with a gradient: Downwards in the direction of the supply opening.
- ▶ Use a bracket at each connection from horizontal pipes.

Material	
Single wall, rigid	aluminium/Stainless steel <sup>(1)</sup>
Flexible	
<sup>(1)</sup> The materials used must comply with the prevailing regulations and standards	

**4.7 Electrical connections**

For the connection(s) of the boiler **Gas 610 ECO PRO**: The features and instructions described are for each boiler module.

### 4.7.1. Control unit

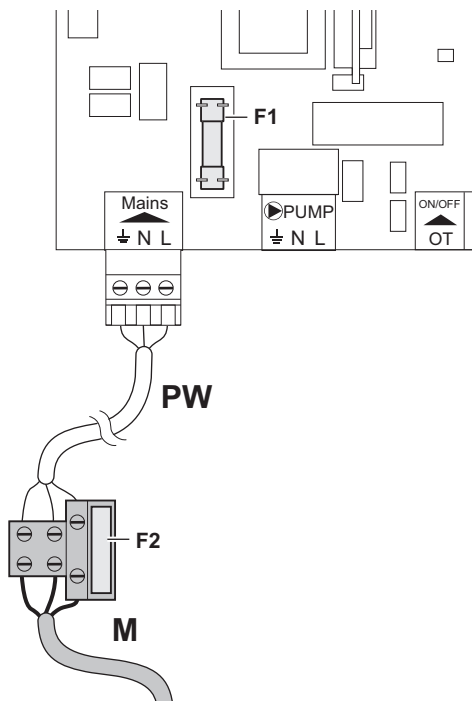

- PW** Pre-wired in the boiler
- M** Three wired power cord

The boiler has a detection phase. The boiler is fully pre-wired. The boiler is suitable for a 230 V / 50 Hz power supply with live/neutral/earth. Other connection values are only acceptable if an isolating transformer is installed. Connect the wires of the mains lead to the appropriate terminal block. This can be found to the left underneath the connector **MAINS**. (The mains lead is not supplied).



#### CAUTION

- ▶ In the case of a fixed connection to the power cord, you must always install a main bipolar switch with an opening gap of at least 3 mm.
- ▶ When connecting the mains lead to the plug, the earth wire must be longer than the electrical wires.

The main characteristics of the control unit are described in the table below.

T003486-E

Power supply voltage	230 VAC/50Hz
Rating of the main fuse F2 (230 VAC)	10 AT
Fuse rating F1 (230 VAC)	2 AT
Maximum power consumption of the pump	300 VA



#### WARNING

The following boiler components are at a voltage of 230V:

- ▶ Electrical connection of the heating pump (Central heating) (if used).
- ▶ Electrical connection of the combined gas valve unit.
- ▶ Fan.
- ▶ The majority of components in the control panel.
- ▶ Ignition transformer.
- ▶ Connection of the power supply cable.



The boiler has a unique boiler code. This, together with other data, incl. boiler type, counter readings, etc. is stored in a **(PSU)** that belongs with the boiler. If the control unit is replaced, the counter readings remain stored in it.

It is possible to connect various control, safety and regulation systems to the boiler. The heat output of the boiler can be controlled as follows:

- ▶ Adjustable control: The output varies between the minimum and maximum value on the basis of the value determined by the controller.
- ▶ Analogue setting: Where the heat output or the temperature is controlled by a 0-10V signal.

- ▶ On/Off setting: where the heat output modulates between the minimum and maximum value based on the flow temperature set in the boiler.

 The standard control PCB (**PCU-06**) can be extended with the following, for example: "Accessories", page 19

#### 4.7.2. Recommendations

---



##### WARNING

- ▶ Only qualified professionals may carry out electrical connections, always with the power off.
- ▶ The boiler is entirely pre-wired. Do not modify the connections inside the control panel.
- ▶ Earth the appliance before making any electrical connections.

Make the electrical connections of the boiler according to:

- ▶ The instructions of the prevailing standards.
- ▶ The instructions on the electrical diagrams provided with the boiler.
- ▶ The recommendations in the instructions.



##### CAUTION

Separate the sensor cables from the 230 V cables.

#### 4.7.3. Standard control PCB

---

The protection PCB **SU**, which protects the boiler, is connected to the standard control PCB **PCU-06**.

Various thermostats and controllers can be connected to the standard control PCB (**PCU-06**). The possible connections on the standard control PCB are described in the following paragraphs.



#### 4.7.4. Connecting the on/off control

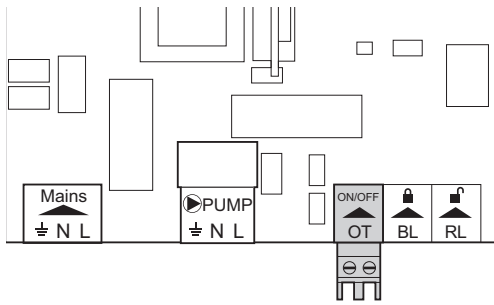

T003482-A

The boiler can be controlled with an on/off controller. Connect the controller to the **ON/OFF-OT** connector. (It does not matter which wire is connected to which cable clamp).

#### 4.7.5. Connecting modulating controller

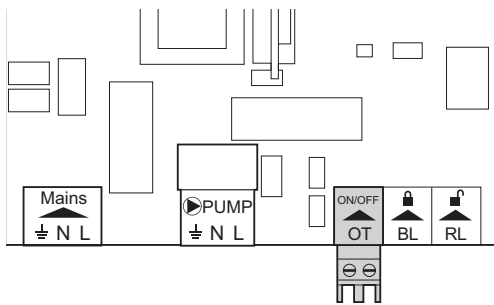

T003482-A

The boiler is fitted with a **OpenTherm** connection as standard. As a result, modulating **OpenTherm** room controllers can be connected without any further adjustments. Connect the two-wire cable to terminals **ON/OFF-OT** of the connector (It does not matter which wire is connected to which cable clamp).

#### 4.7.6. Shutdown input

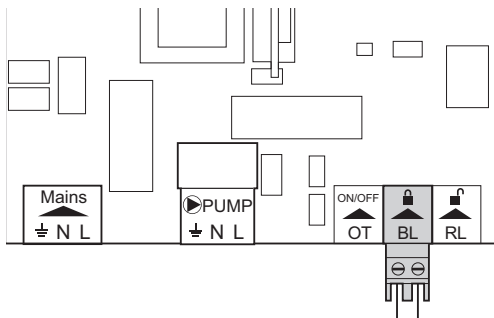

T003483-B

The boiler has a shutdown input (Normally closed contact). If this contact is opened, the boiler will go into shutdown or be locked out. This input can be used for example in combination with the flue gas thermostat (Accessory). This input is on the **BL** terminals of the connector.



#### CAUTION

Only suitable for potential-free contacts.



Remove the bridge before using the input

The behaviour of the input can be changed using parameter

**P35**.

### 4.7.7. Release input

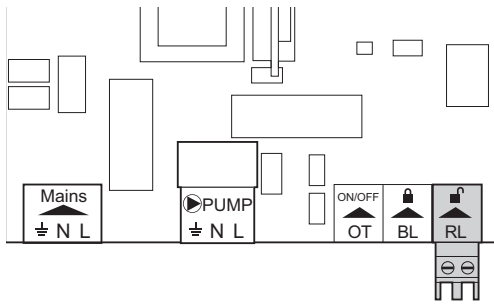

T003484-B

**CAUTION**

Only suitable for potential-free contacts.

The waiting time of the input can be changed using parameter **P32**.

### 4.7.8. System pump

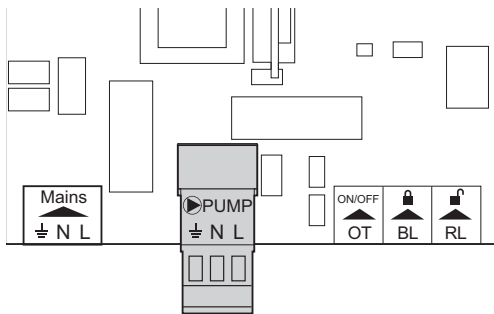

T003485-B

An external central heating pump can be connected to the **Pump** terminals of the connector. The maximum input power is 300 VA.

For more information on controlling a modulating pump See paragraph: "Connection possibilities for the PCB (SCU-S05)", page 42

### 4.7.9. PC/Laptop connection

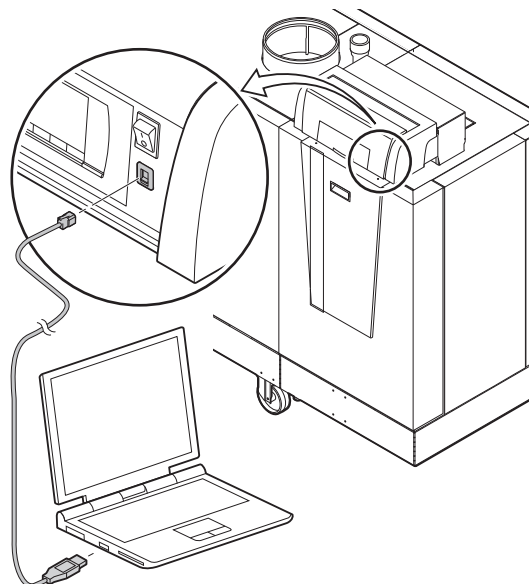

T003492-E

A PC can be connected to the **RS 232** input using an USB cable. Using the **Recom** PC/Laptop service software, you can enter, change and read out various boiler settings.

### 4.7.10. Connection possibilities for the PCB (SCU-S05)

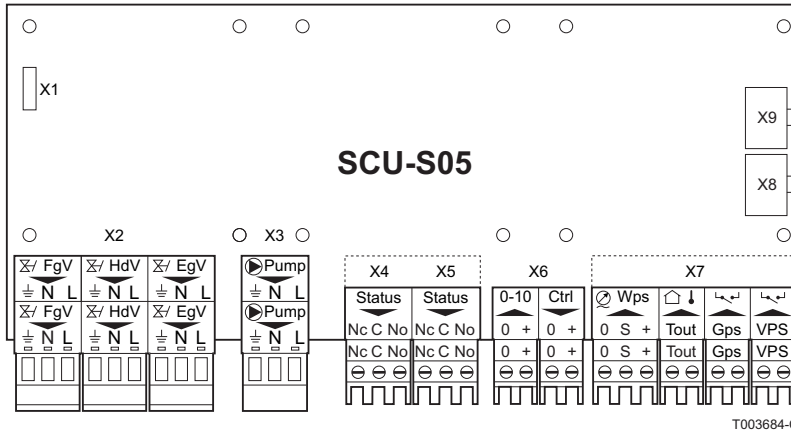

To set the parameter selected: See the Installation and service manual **HMI Gas 310/610 ECO PRO** for comprehensive operating instructions.



#### CAUTION

On removing this PCB, the boiler will show fault code **E:38**. To prevent this fault, an auto-detect must be carried out after removing this PCB.

#### ■ Flue gas damper control (FgV)

Not applicable.



R000303-A

#### ■ Hydraulic valve control (HdV)

In a cascade configuration, a hydraulic valve prevents heat loss when the boiler is not running. Connect the hydraulic valve to the **HdV** terminals of the terminal strip. The running time of the hydraulic valve must be programmed with parameter **P30**.



R000304-A

#### ■ Control of external gas valve (EgV)

If there is a heat demand, an alternating voltage of 230 VAC, 1 A (maximum) becomes available on the **EgV** terminals of the connector to control an external gas valve.



R000305-A

### ■ Connecting a shunt pump (Pump)

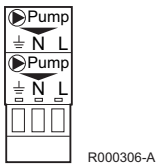

R000306-A

If required, a shunt pump may also be installed on the terminals **Pump** of the connector. Only an on/off pump can be controlled. The pump is activated during lock outs **SE:9** (**SW:4,5** and **6**). The maximum input power is 300 VA.

### ■ Operation signal and failure signal (Status)

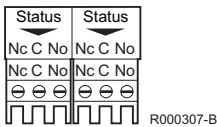

R000307-B

The alarm or operation signal is selected using parameter **P26** (Connector **X4**).

The alarm or operation signal is selected using parameter **P27** (Connector **X5**).

- ▶ If the boiler is operating, the operation signal can be switched via a potential-free contact (maximum 230 VAC, 1 A) on the **No** and **C** terminals of the connector.
- ▶ If the boiler locks out, the alarm can be transmitted via a potential-free contact (maximum 230 VAC, 1 A) on the **Nc** and **C** terminals of the connector.

### ■ Analogue output (Ctrl)

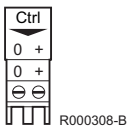

R000308-B

The function of the analogue output can be set using parameter **P36**.

An outgoing 0-10 V signal can be used either to report the supplied heat output or the supplied temperature.

The speed of the system pump can be controlled with an outgoing 0-10 V signal. (Only possible if the pump is suitable for this).

#### Control of 0-10V Wilo system pump

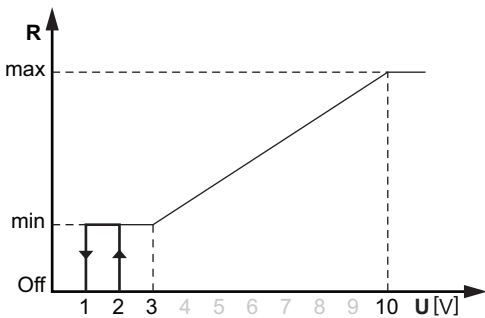

T003802-B

- R** Pump regime
- min** Minimum pump speed
- max** Maximum pump speed
- Off** The pump is off
- U** Output signal (V)

Output signal (V)	Description
<1	Pump off
1 - 2	Hysteresis
2 - 3	Pump on (Minimum pump speed)
3 - 10	Pump modulates (Linear)

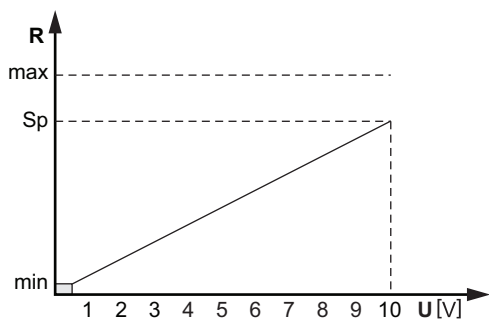

T003803-B

### Control of 0 - 10 V Grundfos system pump

<b>R</b>	Pump regime
<b>min</b>	Minimum pump speed
<b>max</b>	Maximum pump speed
<b>Sp</b>	Nominal set-point
<b>U</b>	Output signal (V)

Output signal (V)	Description
<0,5	Pump on (Minimum pump speed)
>0,5	Pump modulates (Linear)

### Control of PWM system pump

In this case, the 0-10 V signal controls the system pump linear.

### Message about the supplied temperature

Output signal (V)	Temperature °C	Description
0,5	-	Lock out
1 - 10	10 - 100	Delivered temperature

### Message about the supplied heat output

Output signal (V)	Heat output (%)	Description
0	0	Boiler off
0,5	-	Lock out
2,0 - 10 <sup>(1)</sup>	20 - 100	Heat output supplied

(1) Dependent on the minimum modulation depth (set speeds, standard 20%)

### ■ Analogue input (0-10 V)

The function of the analogue input can be set using parameter **P37**.

This control can be based on temperature or heat output. If this input is used for 0-10 V control, then the boiler OT communication is ignored.

#### Analogue temperature-based control (°C)

The 0 - 10 V signal controls the boiler flow temperature. This control modulates on the basis of flow temperature, whereby the heat output varies between the minimum and maximum values on the basis of the flow temperature set point calculated by the controller.

Input signal (V)	Temperature °C	Description
0 - 1,5	0 - 15	Boiler off
1,5 - 1,8	15 - 18	Hysteresis
1,8 - 10	18 - 100	Temperature required

#### Analogue heat output-based control (%)

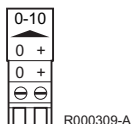

R000309-A

The 0 - 10 V signal controls the boiler output. The minimum and maximum values are limited. The minimum output is linked to the boiler's modulation depth. The output varies between the minimum and maximum value on the basis of the value determined by the controller.

Input signal (V)	Heat output (%)	Description
0 - 2,0 <sup>(1)</sup>	0 - 20	Boiler off
2,0 - 2,2 <sup>(1)</sup>	20 - 22	Hysteresis
2,0 - 10 <sup>(1)</sup>	20 - 100	Heat output requested

(1) Dependent on the minimum modulation depth (set speeds, standard 20%)

### ■ Hydraulic pressure sensor (Wps)

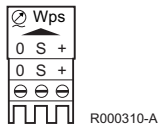

The hydraulic pressure sensor registers the water pressure and can shut the boiler down when the minimum water pressure is reached. To activate this blocking option, a minimum pressure must be set with parameter **P28**. Connect the hydraulic pressure sensor to the **Wps** terminals of the terminal strip.

- 0 = Earth or neutral of the power supply
- S = Signal or output from the sensor
- + = Supply voltage

### ■ Connecting the (Tout) outside temperature sensor

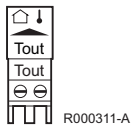

An outside sensor can be connected to the **Tout** terminals of the connector (Accessory). Where there is an on/off thermostat controller, the boiler will control the temperature with the set point of the internal heating curve.

If an outside temperature sensor is connected, it is possible to adapt the heating curve. The setting can be modified using parameters **P1**, **P22**, **P23** and **P24**.

**i** A **OpenTherm** controller can also use this outside sensor. The heating curve required must then be set on the controller.

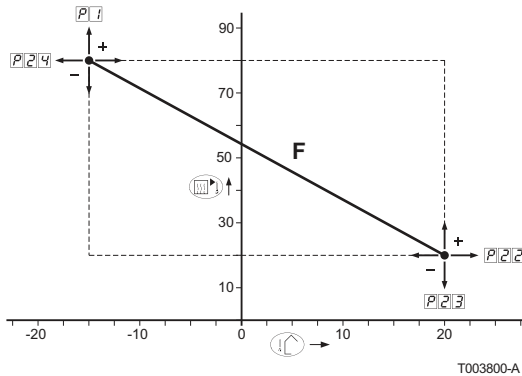

### ■ Pressure switch minimum (Gps)

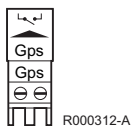

The minimum gas pressure switch shuts the boiler down if the inlet gas pressure becomes too low. Check the setting of the minimum gas pressure switch **Gps**. (See table below). Connect the minimum gas pressure switch to the **Gps** terminals of the connector. The presence of the gas pressure switch must be set using parameter **P29**.

Pressure switch minimum	
Gas 310 ECO PRO	Minimum value
285	14 mbar
355	13 mbar
430	10 mbar

Pressure switch minimum	
500	10 mbar
575	10 mbar
650	10 mbar

### ■ Gas valve leak proving system (Vps)

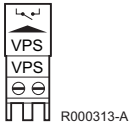

The gas leakage control checks and controls the safety valves on the gas block. The test takes place before the boiler starts up. In the event of a leak in the gas block, the boiler will lock out. The pressure switch must be set at 50 % of the admission pressure (See table below).

Connect the gas leakage control to the Vps terminals of the terminal strip. The presence of the gas leak control must be specified using parameter **P33** in the setting mode.

Boiler type Gas 310 ECO PRO	Gas inlet pressure (Max)	VPS setting (Max)
285	30	15
355	30	15
430	100	40
500	100	40
575	100	40
650	30	15

### 4.8 Electrical diagram

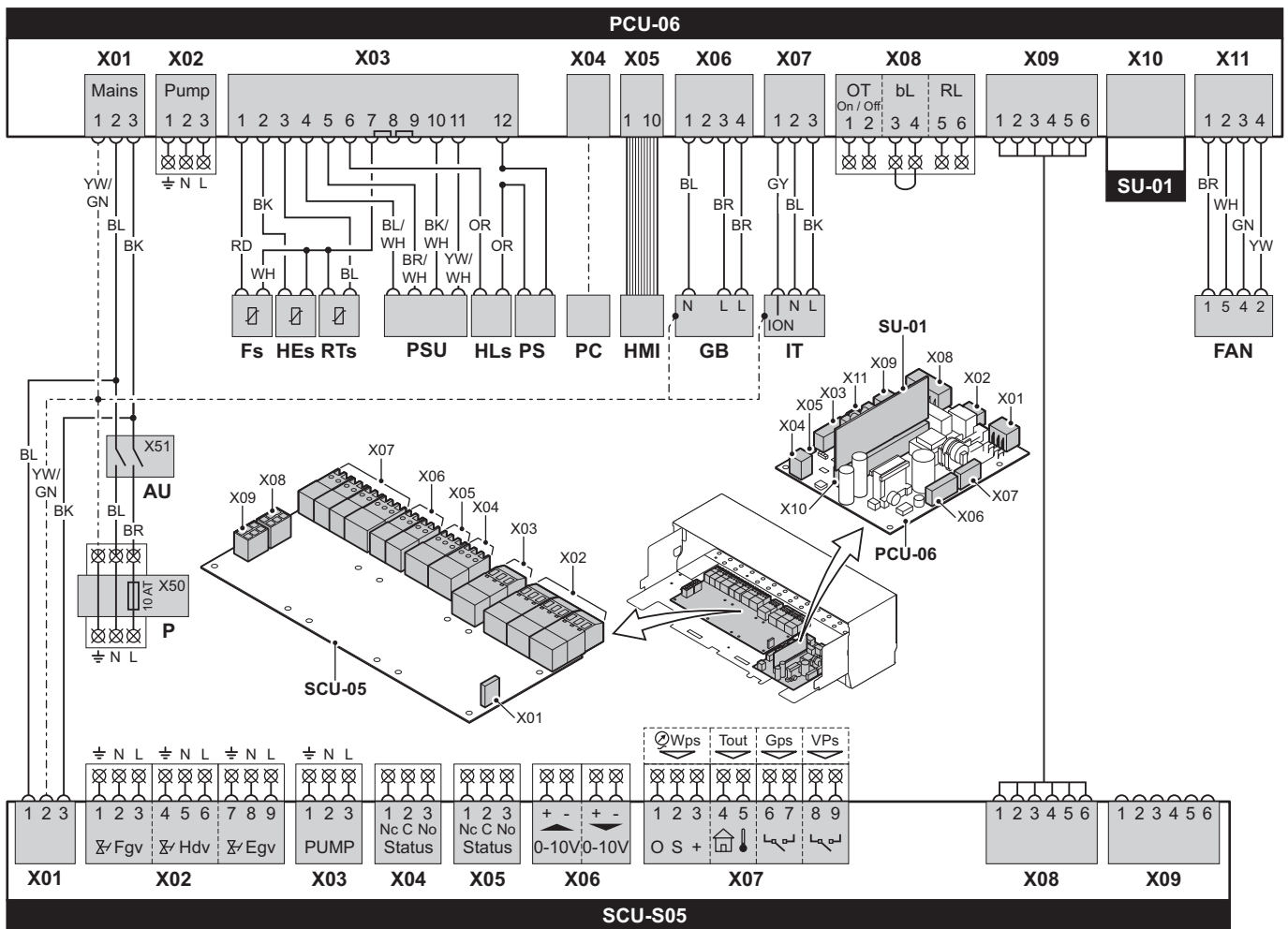

R000236-C

<b>SCU-S05</b>	Extended control PCB	<b>RTs</b>	Return sensor
<b>PCU-06</b>	Standard control PCB	<b>PSU</b>	Storage parameter
<b>SU-01</b>	Safety PCB	<b>HLs</b>	Safety thermostat
<b>AU</b>	On/Off switch	<b>PS</b>	Air differential pressure switch
<b>P</b>	Power supply	<b>PC</b>	Connecting a computer
<b>N</b>	Neutral	<b>HMI</b>	Control panel
<b>L</b>	Phase	<b>GB</b>	Gas block
<b>Fs</b>	Flow switch	<b>IT</b>	Ignition transformer
<b>HEs</b>	Heat exchanger sensor	<b>FAN</b>	Fan

### 4.9 Filling the system



**CAUTION**

Great care is required during water treatment. For more information, refer to our publication water quality rules. The rules in the aforementioned document must be respected. This manual forms a part of the documentation supplied with the boiler.

### 4.9.1. Water treatment

In most cases, the boiler and the central heating installation can be filled with normal tap water and no water treatment will be necessary.



#### WARNING

Do not add chemical products to the central heating water without consulting **Remeha**. For example: antifreeze, water softeners, products to increase or reduce the pH value, chemical additives and/or inhibitors. These may cause faults in the boiler and damage the heat exchanger.



- ▶ Rinse the central heating installation with at least 3x the volume of the central heating installation. Flush the DHW pipes with at least 20 times the volume of the pipes.
- ▶ For untreated water, the pH value of the water in the installation must be between 7 and 9 and for treated water between 7 and 8.5.
- ▶ The maximum hardness of the water in the installation must be between 0.5 - 20.0 °dH (Depending on the total installed heat output).
- ▶ For more information, refer to our publication water quality rules. The rules in the aforementioned document must be respected.

### 4.9.2. Filling the siphon

1. Fill the siphon with water via the condensate tank (Up the level marker).



#### CAUTION

Reinsert the condensate collector sealant cap.

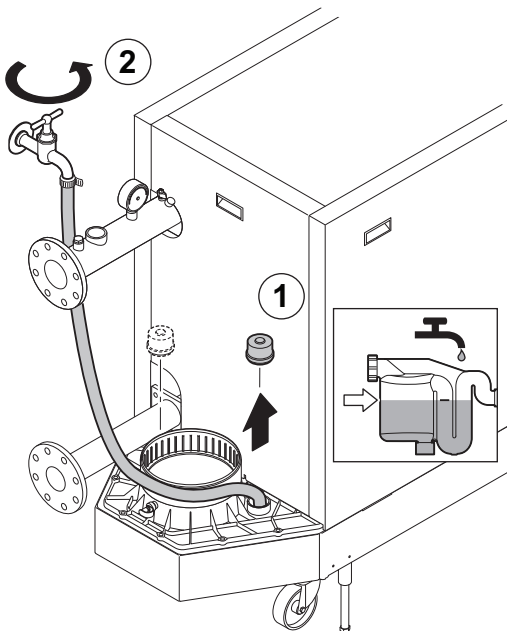

T003489-D

### 4.9.3. Filling the system

---

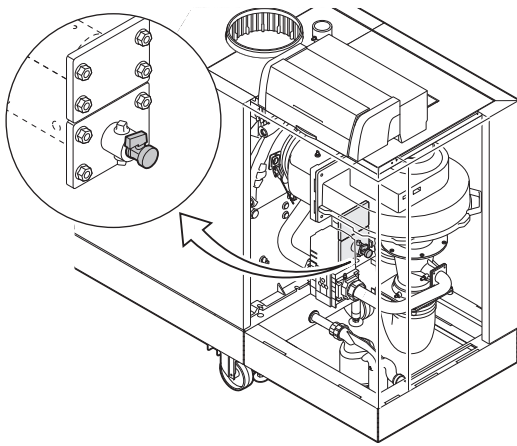

T003772-F

1. Fill the system with clean tap water. The boilers can function at an operating pressure of between 0.8 - 7 bar.
2. Check the tightness of the water connections.



- ▶ If the water pressure is lower than 0.8 bar, the symbol  will appear. Only with the hydraulic pressure sensor connected (Accessory). If necessary, top up the water level in the heating system.
- ▶ A filling and drain cock is fitted on the front section as standard (1/2").

# 5 Commissioning

## 5.1 Control panel



For operation of the boiler **Gas 610 ECO PRO**: Each module has its own instrument panel.



See the Installation and service manual **HMI GAS 310/610 ECO PRO** for comprehensive operating instructions. This includes information about changing and reading parameters, the meaning of fault codes and deleting the failure memory.

### 5.1.1. Functions of the keys

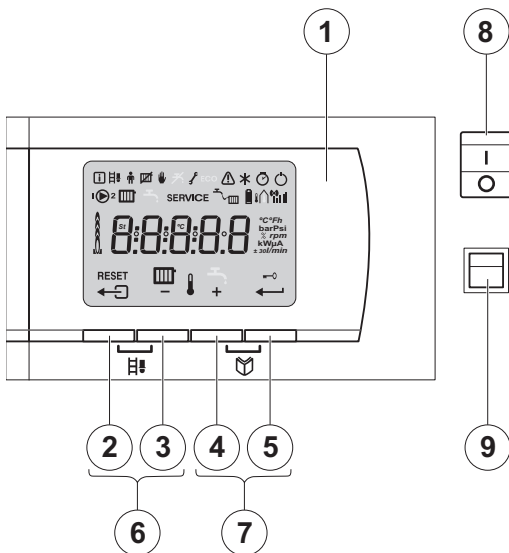







T003479-D

- 1 Display
- 2 [Escape] or **RESET** key
- 3 Heating temperature key or [-]
- 4 [+] key
- 5 [Enter] or cancel Key lock-out
- 6 [Chimney-sweeping] keys (press the 2 and 3 keys simultaneously)
- 7 [Menu] keys (press the 4 and 5 keys simultaneously)
- 8 On/Off switch
- 9 PC connection

### 5.1.2. Meaning of the symbols on the display

	Information menu: Reading the various current values.		On/Off switch (0/1): After 5 lock-outs, the boiler must be switched off/on again.
	Chimney-sweeping position: Forced full or part load for CO <sub>2</sub> measurement.		Circulation pump: The pump operates.
	User menu: Parameters at user level can be changed.		Central heating function: Access to central heating temperature parameter.
	Heating programme deactivated: The heating function is deactivated.		Locking the keys: Key lock-out is activated.
	Manual mode: Boiler is set to manual operation.	<b>SERVICE</b>	Yellow display with the symbols: + <b>SERVICE</b> +  (Maintenance message).
	Service menu: Parameters at installer level can be changed.		Water pressure: The water pressure is too low. Only with the hydraulic pressure sensor connected (Accessory).

	Defect: Boiler indicates a fault. This can be seen from the <b>E</b> code and red display.		Antifreeze protection: Boiler is running in frost protection mode.
	Hour counter menu: Readout of the operating hours, number of successful starts and hours on mains supply.		Burner level: Output level .
	Outside sensor: Only if an outside temperature sensor is connected (Accessory).		Signal strength symbol: Signal strength of the wireless controller (If connected)..
	Battery symbol: Status of battery of wireless controller (If connected).		

## 5.2 Check points before commissioning

### 5.2.1. Preparing the boiler for commissioning



For work on the boiler **Gas 610 ECO PRO**: The features and instructions described are for each boiler module.



#### WARNING

Do not put the boiler into operation if the supplied gas is not in accordance with the approved gas types.

#### Preparatory procedure for boiler commissioning:

- ▶ Check that the gas type supplied matches the data shown on the boiler's data plate.
- ▶ Check the gas circuit.
- ▶ Check the hydraulic circuit.
- ▶ Check the water pressure in the heating system.
- ▶ Check the tightness of the flue gases evacuation and air inlet connections.
- ▶ Check the electrical connections to the thermostat and the other external controls.
- ▶ Check the other connections.
- ▶ Test the boiler at full load. Check the setting of the gas/air ratio and, if necessary, correct it.
- ▶ Test the boiler at part load. Check the setting of the gas/air ratio and, if necessary, correct it.
- ▶ Finalizing work.
- ▶ Complete the checklist.



See chapter: "Checklist for commissioning", page 77.

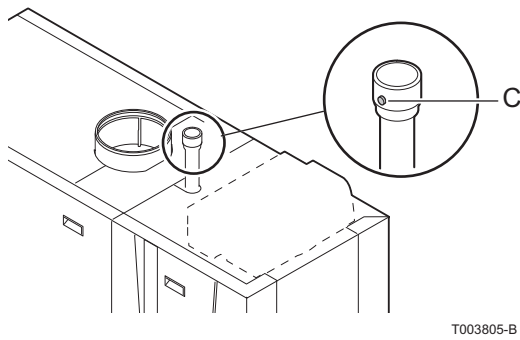

### 5.2.2. Gas circuit



#### WARNING

Ensure that the boiler is switched off.

1. Open the main gas supply.
2. Remove the casings on the inspection side.
3. Measure the inlet gas pressure via the measuring point **C** on the gas pipe.  
The pressure must be the same as the one shown on the rating plate.



#### WARNING

 To ascertain the gas types permitted, see chapter: "Equipment categories", page 12.

4. Check the tightness of the gas line, including the gas valves.
5. Purge the gas supply pipe by unscrewing the screw from the gas pressure socket **C**. Tighten the measurement point when the pipe has been sufficiently purged.

### 5.2.3. Hydraulic circuit

- ▶ Check the syphon — this must be completely filled with clean water (Up the level marker).
- ▶ Check the tightness of the water connections.

### 5.2.4. Connections for the air and exhaust pipes

- ▶ Check the tightness of the flue gases evacuation and air inlet connections.

### 5.2.5. Electrical connections

- ▶ Check the electricity supply.
- ▶ Check the electrical connections.

## 5.3 Commissioning the boiler

1. Turn on the boiler using the on/off switch.
2. Set the controls (thermostats, control system) so that they request heat.

3. The start-up cycle begins and cannot be interrupted. During the start-up cycle, the display shows the following information:  
 A short test where all segments of the display are visible.  
 F : : Software version  
 P : : Parameter version  
 The version numbers are displayed alternately.

By pressing the key for a short time, the current operating status is shown on the display:

**Error during the start-up procedure:**

- ▶ No information is shown on the display:
  - Check the mains supply voltage
  - Check the main fuses
  - Check the fuses on the control panel:  
(F1 = 2 AT, F2 = 10 AT)
  - Check the connection of the mains lead to the connector in the instrument box
  - Check the display flat cable
- ▶ A fault is indicated on the display by the fault symbol and a flashing fault code:
  - The meaning of the error codes is given in the error table.
  - Press for 2 seconds on key **RESET** to restart the boiler.

Heat demand	Heat demand stopped
1: Fan ON	5: Burner stop
2: Boiler is igniting	6: Post-circulation of the pump
3: Heating System	0: Standby

In STAND-BY, the display normally shows the water pressure next to (only when the hydraulic pressure sensor is connected) and the symbols and .

## 5.4 Gas settings

---

The boiler is preset in the factory to operate on natural gas G20 (Gas H).

### 5.4.1. Setting the air/gas ratio (Full load)

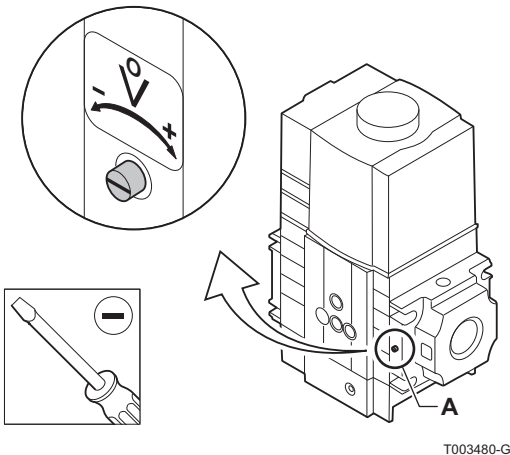
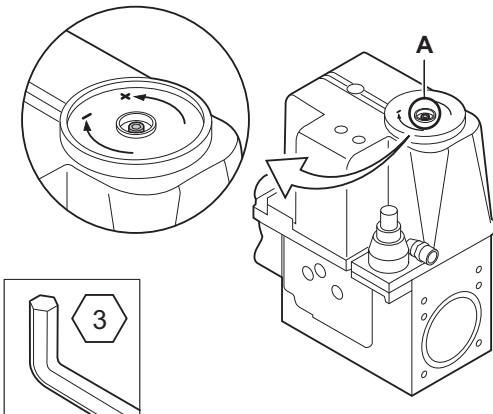

**i** For checking and/or setting the boiler **Gas 610 ECO PRO**: The features and instructions described are for each boiler module. Make sure that the other boiler module is out of operation during this check and/or setting.

**i** Measure the inlet gas pressure via the measuring point **C** on the gas pipe. The pressure must be the same as the one shown on the rating plate.

1. Unscrew the plug of the flue gas measurement point.
2. Connect the flue gas analyser.

**i** Ensure that the opening around the sensor is completely sealed when taking measurements.

3. Set the boiler to full load. Press the two keys simultaneously. The display shows . The symbol appears.
4. Measure the percentage of O<sub>2</sub> or CO<sub>2</sub> in the flue gases.

**i** The 5 to 9 section boilers are supplied with a different gas block from the 10 section boiler. See drawing for the position of control screw **A** for full load.

5. If this rate does not match the required value, correct the gas/air ratio using the adjustment screw **A** on the gas valve unit. The direction in which the adjustment screw must be turned to increase or decrease the gas flow is indicated on the gas block.
6. Check the flame through the flame inspection window.

**i** The flame must not be detached.

O <sub>2</sub> /CO <sub>2</sub> control and setting values at full load for G20 (Gas H)		
Gas 310 ECO PRO	O <sub>2</sub> (%)	CO <sub>2</sub> (%)
All versions	4.3 - 4.8 <sup>(1)</sup>	9.0 <sup>(1)</sup> - 9.3
(1) Nominal value		



#### CAUTION

The CO<sub>2</sub> values when operating at full load must be higher than the values when operating at low load.

### 5.4.2. Setting the air/gas ratio (Part load)



T004391-A

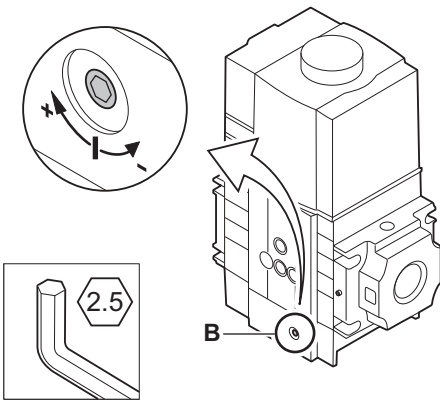
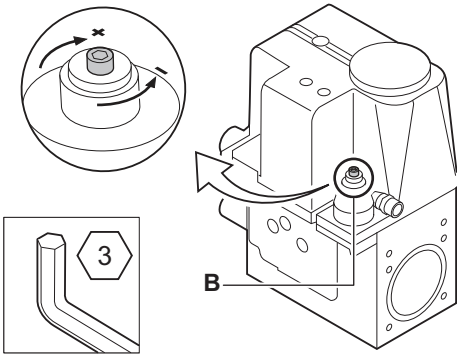

T003481-D

**i** For checking and/or setting the boiler **Gas 610 ECO PRO**: The features and instructions described are for each boiler module. Make sure that the other boiler module is out of operation during this check and/or setting.

**i** Measure the inlet gas pressure via the measuring point **C** on the gas pipe. The pressure must be the same as the one shown on the rating plate.

1. Unscrew the plug of the flue gas measurement point.
2. Connect the flue gas analyser.

**i** Ensure that the opening around the sensor is completely sealed when taking measurements.

3. Set the boiler to part load. Press the two **H** keys simultaneously. The symbol **H** appears. Press the **[-]** key until **L3** is displayed.

4. Measure the percentage of O<sub>2</sub> or CO<sub>2</sub> in the flue gases.

**i** The 5 to 9 section boilers are supplied with a different gas block from the 10 section boiler. See drawing for the position of control screw **B** for part load.

5. If this rate does not match the required value, correct the gas/air ratio using the adjustment screw **B** on the gas valve unit. The direction in which the adjustment screw must be turned to increase or decrease the gas flow is indicated on the gas block.

6. Check the flame through the flame inspection window.

**i** The flame must be stable.

O <sub>2</sub> /CO <sub>2</sub> control and setting values at part load for G20 (Gas H)		
Gas 310 ECO PRO	O <sub>2</sub> (%)	CO <sub>2</sub> (%)
All versions	4.8 <sup>(1)</sup> - 5.4	8.7 - 9.0 <sup>(1)</sup>
(1) Nominal value		



**CAUTION**

The CO<sub>2</sub> values when operating at low load must be lower than the values when operating at full load.



## 5.5 Checks and adjustments after commissioning

### 5.5.1. Finalizing work

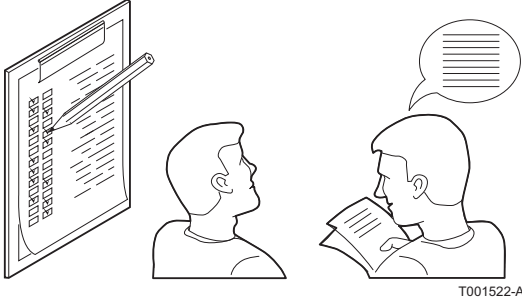

1. Remove the measuring equipment.
2. Put the flue gas sampling plug back in place.
3. If installed: Check the setting of the minimum gas pressure switch **Gps**. The pressure switch must be set at 10 mbar.
4. If installed: Check the setting of the pressure switch for gas leakage control **Vps**. The pressure switch must be set at 50 % of the admission pressure (Up to 40 mbar).  
 ☞ See chapter: "Connection possibilities for the PCB (SCU-S05)", page 42
5. Reapply the casing on the inspection side.
6. Push key **RESET** to return the boiler to normal operating mode.
7. Raise the temperature in the heating system to approximately 70°C.
8. Shut down the boiler.
9. After about 10 minutes, vent the air in the heating system.
10. Switch on the boiler.
11. Checking the hydraulic pressure. If necessary, top up the water level in the heating system.
12. Tick the gas category used on the data plate.
13. Explain the operation of the installation, the boiler and the regulator to the users.
14. Give all the instruction manuals to the user. A documentation folder can be found in the frame of the boiler. Use it to store all boiler manuals together with other documents relating to the installation.
15. Finalizing work.
16. Complete the checklist. ☞ See chapter: "Checklist for commissioning", page 77.

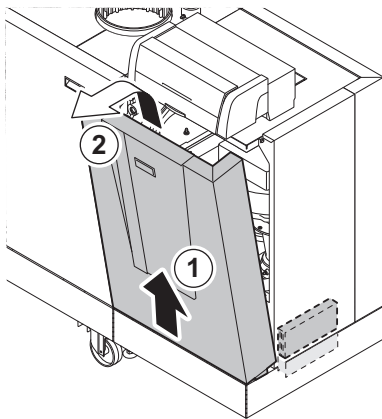

The various boiler parameters are preset in the factory. These factory settings are suitable for the most common heating systems. For other systems and situations, the parameters can be modified.

## 5.6 Reading out measured values

### 5.6.1. Reading the various current values

The following current values can be read off the information menu **i**:

- ▶ **S****E** = State.
- ▶ **S****U** = Sub-status.

- ▶  $\boxed{t} \boxed{1}$  = Flow temperature (°C).
- ▶  $\boxed{t} \boxed{2}$  = Return temperature (°C).
- ▶  $\boxed{t} \boxed{4}$  = Outside temperature (°C)  
Only with an outside temperature sensor (Accessory).
- ▶  $\boxed{t} \boxed{6}$  = Exchanger temperature (°C).
- ▶  $\boxed{S} \boxed{P}$  = Internal set point (°C).
- ▶  $\boxed{F} \boxed{L}$  = Ionization current (µA).
- ▶  $\boxed{n} \boxed{F}$  = Fan speed (rpm).
- ▶  $\boxed{P} \boxed{r}$  = Water pressure (bar (MPa)).  
Only with the hydraulic pressure sensor connected (Accessory).
- ▶  $\boxed{P} \boxed{o}$  = Supplied relative heat output (%).
- ▶  $\boxed{S} \boxed{1}$  = Pressure switch minimum Gps ( $\boxed{-}$  = Not connected /  $\boxed{1}$  = Gas pressure OK /  $\boxed{2}$  = Gas pressure incorrect)  
Only with connected minimum gas pressure switch (Accessory)
- ▶  $\boxed{S} \boxed{2}$  = Gas valve leak proving system Vps ( $\boxed{-}$  = Not connected /  $\boxed{1}$  = No gas leak /  $\boxed{2}$  = Gas leak present)  
Only with connected gas leakage control (Accessory).
- ▶  $\boxed{U} \boxed{1}$  = Analogue input (V).
- ▶  $\boxed{U} \boxed{2}$  = Analogue output (V).

 See the Installation and service manual **HMI GAS 310/610 ECO PRO** for comprehensive operating instructions. This includes information about changing and reading parameters, the meaning of fault codes and deleting the failure memory.

## 5.7 Changing the settings

---

The boiler control panel is set for the most common heating systems. With these settings, practically all heating systems operate correctly. The user or installer can optimise the parameters according to own preferences.

 See the Installation and service manual **HMI GAS 310/610 ECO PRO** for comprehensive operating instructions. This includes information about changing and reading parameters, the meaning of fault codes and deleting the failure memory.

# 6 Switching off the boiler

## 6.1 Installation shutdown

If the central heating system is not used for a long period, we recommend switching the boiler off.

- ▶ Switch the On/Off switch to Off.
- ▶ Switch off the boiler electrical power supply.
- ▶ Shut off the gas supply.
- ▶ Ensure that the boiler and system are protected against frost damage.



### CAUTION

In the event of low temperatures, we recommend that the installation continues to operate at a lower temperature. This prevents freezing.

## 6.2 Antifreeze protection



### CAUTION

Drain the boiler and central heating system if you are not going to use your home or the building for a long time and there is a chance of frost.

1. Set the temperature control low, for example at 10°C.

If there is no demand for heat, the boiler will only switch on in order to prevent frost damage.

When the heating water temperature in the boiler falls by too much, the integrated protection system in the boiler starts up. This protection functions as follows:

(The circulation pump must be electrically connected to boiler)

- ▶ The circulation pump switches on if the water temperature is lower than 7°C.
- ▶ If the water temperature is lower than 4°C, the boiler starts up.
- ▶ If the water temperature is higher than 10°C, the boiler shuts down and the circulation pump continues to run for a short time



### CAUTION

The integrated protection system only protects the boiler, not the installation.

# 7 Checking and maintenance

## 7.1 General

The cast aluminium/silicon heat exchanger forms the heart of the boiler. When combined with the special geometric shape, the flue gas pollution remains limited. At the top of the heat exchanger, the space between the pins of the heated surface on the flue gas side is slightly larger than further down. This ensures quick distribution of the hot flue gases over the heat exchanger which avoids an excessive load at the top. Due to the boiler's modulating operation, condensation occurs in different locations in the heat exchanger. This ensures that most of the oxidation residues produced are dissolved and rinsed away. The self-cleaning operation therefore functions optimally. Nevertheless, we recommend cleaning the flue gas side of the heat exchanger thoroughly during the annual inspection and service.



Adjust the frequency of inspection and service to the conditions of use. This applies especially to boilers in constant use (for specific processes).

## 7.2 Standard checks



For work on the boiler **Gas 610 ECO PRO**: The features and instructions described are for each boiler module.



### CAUTION

During inspection and maintenance operations, always replace all gaskets on the parts removed.



When it is observed subsequent to inspection or maintenance work that a component in the boiler needs to be replaced, use only original spare parts or recommended spare parts and equipment. A service set containing all necessary components is available for standard maintenance.

We recommend carrying out the standard checks in the following order:

1. Checking the hydraulic pressure.
2. Checking the ionization current.
3. Check the water quality.
4. Checking the air supply connections and flue gas discharge connections.
5. Checking the gas filter for pollution.
6. Checking combustion.
7. Check the air supply hose.
8. Check the dirt trap.
9. Check the air box.

- 10. Check the air pressure differential switch **PS**.
- 11. If installed: Check the gas leakage control **VPS**.
- 12. If installed: Check the minimum gas pressure switch **Gps**.

### Preparation

First heat the boiler on high for about 5 minutes (return temperature 65°C) to dry the heat exchanger on the flue gas side.



#### WARNING

Always wear safety goggles during cleaning work (using compressed air).

### 7.2.1. Checking the hydraulic pressure

The hydraulic pressure must reach a minimum of 0.8 bar. If the water pressure is lower than 0.8 bar, the symbol  will appear. Only with the hydraulic pressure sensor connected (Accessory).



If the water pressure is lower than 0,8 bar, more water should be added.

### 7.2.2. Checking the ionization current

Check the ionization current at full load and low load. The value is stable after 1 minute. If the value lies below 3  $\mu\text{A}$ , replace the ignition electrode.



See the Installation and service manual **HMI GAS 310/610 ECO PRO** for comprehensive operating instructions. This includes information about changing and reading parameters, the meaning of fault codes and deleting the failure memory.

### 7.2.3. Check the water quality

1. Fill a clean bottle with water from the installation/boiler via the filling and drain cock.
2. Check the quality of this water sample or have it checked.

For more information, refer to our publication water quality rules. This manual forms a part of the documentation supplied with the boiler. The rules in the aforementioned document must be respected.

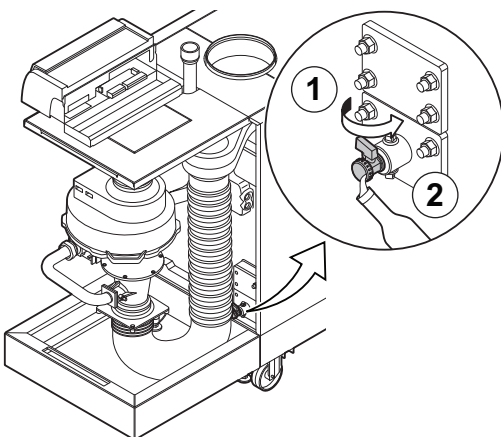

T004854-A

### 7.2.4. Checking the air supply connections and flue gas discharge connections

Check the condition and tightness of the flue gas discharge and air supply connection.

### 7.2.5. Checking the gas filter for pollution

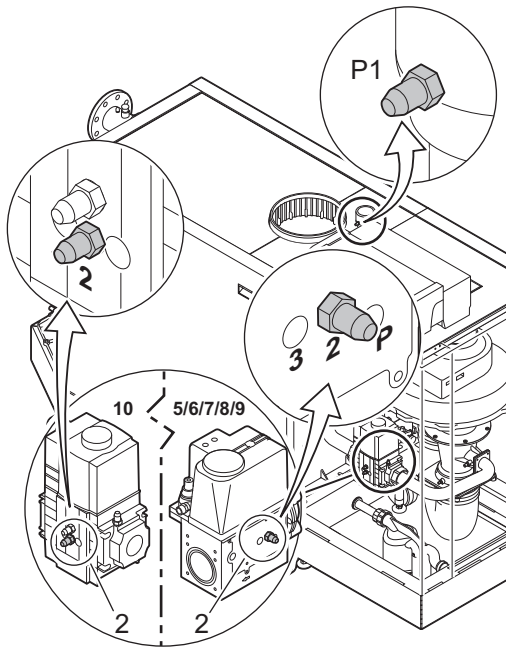

The gas block on the boiler is fitted with a gas filter as standard. Check this for pollution.

1. Set the boiler to full load.
2. Measure the inlet gas pressure via the measuring point P1 on the gas pipe (It should be at least 17 mbar).
3. Check the gas supply pressure at the pressure outlet 2 on the gas valve unit.
4. Compare the values measured with the checking values given in the table:

Inlet gas pressure minimum values 2 on the gas block	
Gas 310 ECO PRO	Minimum value
285	14 mbar
355	13 mbar
430	10 mbar
500	10 mbar
575	10 mbar
650	10 mbar

5. If the measured value is lower than the control value, clean or replace the gas filter.

### 7.2.6. Checking combustion

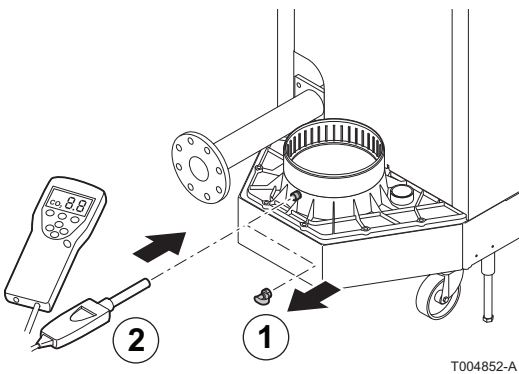

The check on combustion is done by measuring the percentage of O<sub>2</sub>/CO<sub>2</sub> in the flue gas discharge flue.

1. Unscrew the plug of the flue gas measurement point.
2. Insert the measuring sensor of the flue gas analyser in the opening of the flue gas measuring point.



**CAUTION**

Ensure that the opening around the sensor is completely sealed when taking measurements.

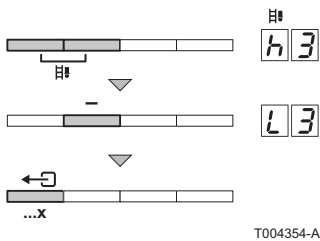

3. Set the boiler to full load. Press the two **H3** keys simultaneously. The **H3** symbol is visible on the menu bar and **h3** appears in the display. The boiler is now operating at full load.
4. Measure the percentage of CO<sub>2</sub> and compare this value with the checking values given. See chapter: "Setting the air/gas ratio (Full load)", page 54.
5. Set the boiler to part load. Press the **[-]** key until **L3** is displayed. The boiler is now operating on part load.
6. Measure the percentage of CO<sub>2</sub> and compare this value with the checking values given. See chapter: "Setting the air/gas ratio (Part load)", page 55.
7. Remove the measuring sensor of the flue gas analyser from the opening of the flue gas measuring point.

- Put the flue gas sampling plug back in place.

### 7.2.7. Check the air supply hose

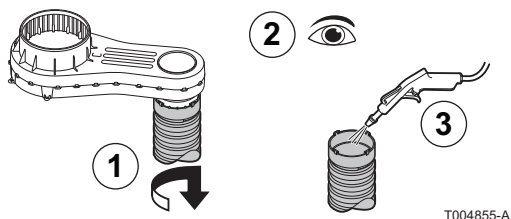

- Disconnect the pipe on the air box side by loosening the bayonet fitting.
- Check the hose for damage and pollution.
- Remove the pollution from the hose with a cloth or soft brush.
- Replace the hose if it is faulty and/or leaking.

### 7.2.8. Check the dirt trap

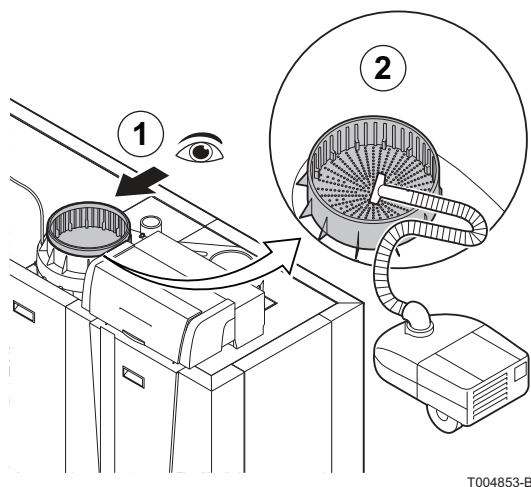

- i** ▶ With room sealed operation, disconnect the air supply pipe above the boiler to access the dirt trap.
- ▶ In room ventilated operation with an air supply filter, remove the filter to access the dirt trap.

- Check the dirt trap on the air supply side for pollution.
- First remove coarse pollution and clean the trap with a vacuum cleaner or a cloth.

### 7.2.9. Check the air box

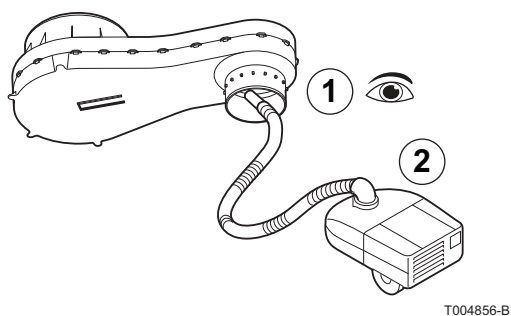

- Check the air box for pollution.
- Clean the dirty air box using a vacuum cleaner. Do this from the connection opening for the air supply hose.

- i** If the air box is dirty, the following components must also be dismantled and cleaned with compressed air:
  - ▶ Non-return valve.
  - ▶ Venturi.
  - ▶ Fan.

### 7.2.10. Check the air pressure differential switch PS

#### Check the air pressure differential switch +

1. Switch the boiler off.
2. Disconnect the silicon hose on the + side (P1) of the air pressure differential switch.
3. Take a large plastic syringe and connect a T piece with a hose connected to the mouth.
4. Connect the + side of the air pressure differential switch to one end of the T piece with a hose.
5. On the other end of the T piece, connect the + side of a pressure gauge.
6. Switch on the boiler.
7. Push the syringe in very slowly until the boiler goes into failure mode; Code **E12**.
8. Make a note of the pressure indicated by the pressure gauge at that point. A switch pressure of between 5.5 mbar and 6.5 mbar is fine. A lower or higher switch pressure indicates a problem with the air pressure differential switch.

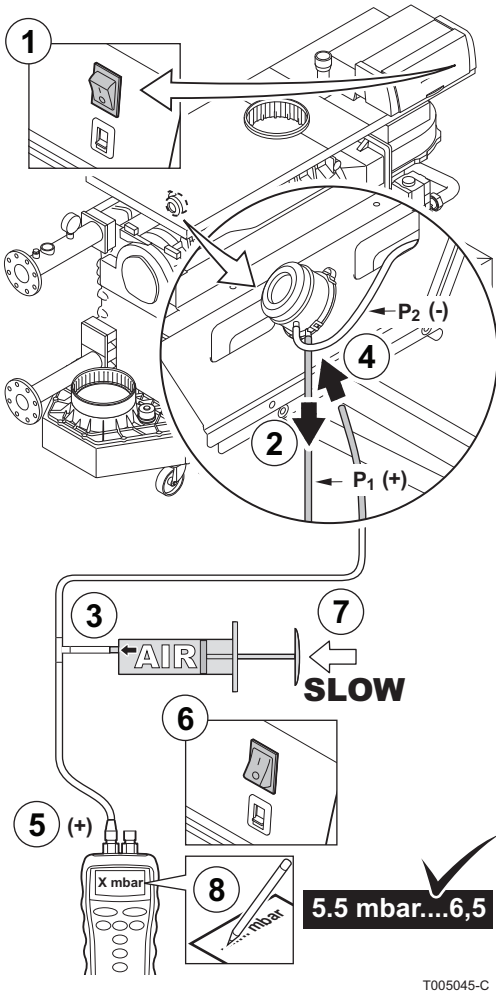

#### Check the air pressure differential switch -

1. Fasten the silicon hose on the + side (P1) of the air pressure differential switch.
2. Disconnect the silicon hose on the - side (P2) of the air pressure differential switch.
3. Connect the - side of the air pressure differential switch to one end of the T piece with a hose.
4. Pull out the syringe until the boiler goes into failure mode; Code **E12**.
5. Make a note of the pressure indicated by the pressure gauge at that point. A switch pressure of between - 5.5 mbar and - 6.5 mbar is fine. A lower or higher switch pressure indicates a problem with the air pressure differential switch.
6. Remove any pollution from the connection points of hoses on the air pressure differential switch.
7. Check the condition and tightness of the hoses of the air pressure differential switch. Replace the hoses if necessary.

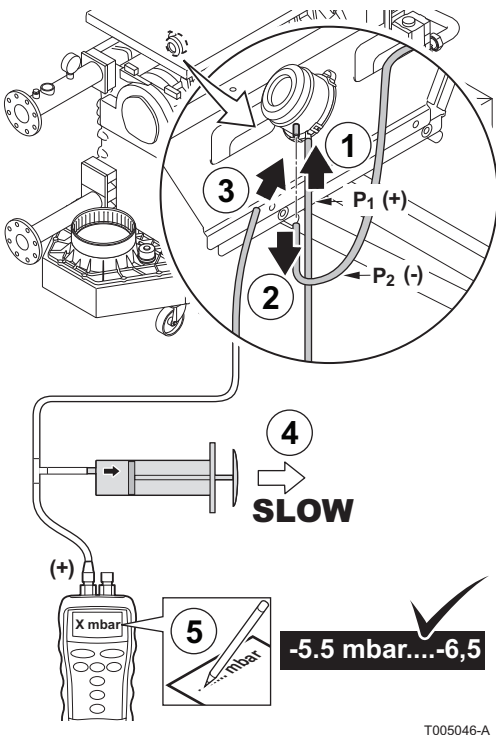

### 7.2.11. Check the gas leakage control VPS

#### A - Leak test

1. Switch the boiler off.
2. Close the boiler gas cock.
3. Remove the pressure from the gas pipe by unscrewing the screw in measuring point P1.
4. As soon as the gas pipe is pressure-free, retighten the screw.
5. Open the screw in measuring point 3 of the gas block (On the opposite side of the VPS pressure switch).
6. Take a large plastic syringe and connect a T piece with a hose connected to the mouth.
7. Connect one end of the T piece to measuring point 3 of the gas block.
8. Connect the other end of the T piece to a pressure gauge.
9. Push the syringe in very slowly until the pressure gauge indicates the minimum inlet gas pressure value.
10. Check the measured pressure for about 30 seconds. If pressure decreases by more than half, this indicates a gas leak.
11. Replace the gas block or the VPS if necessary.

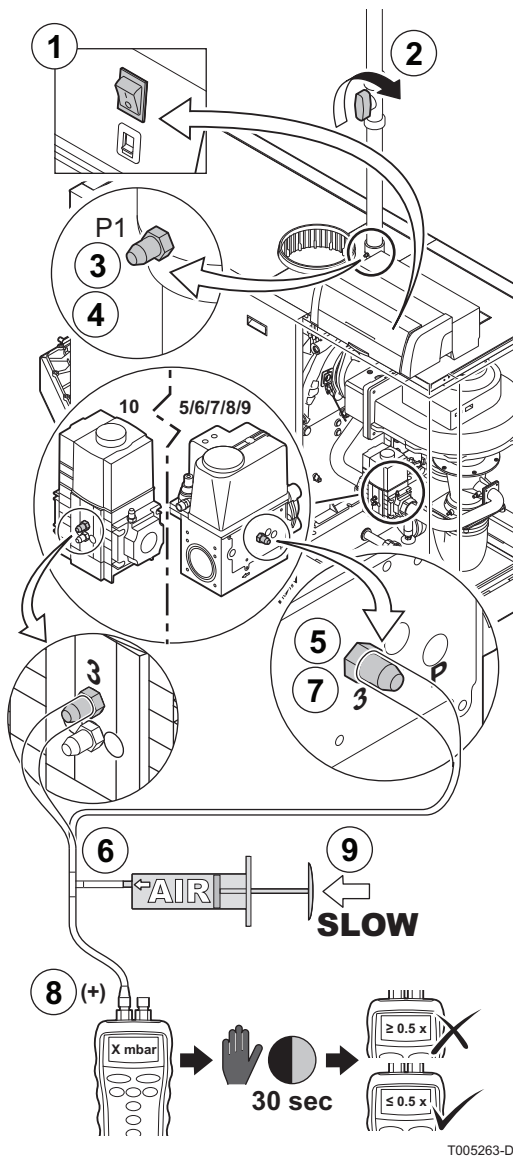

T005263-D

**B - Check the switch value**

1. "Remove the pressure from the gas block; to do so remove the hose connected to measuring point 3 of the gas block" (On the opposite side of the VPS pressure switch).
2. Wait approximately 10 seconds and reconnect the disconnected hose to measuring point 3 of the gas block.
3. Remove the connecting plug from the VPS gas leakage control.
4. Connect an ohmmeter to terminals 2 and 3 of the VPS.
5. Push the syringe in very slowly until the ohmmeter indicates 0 Ohm.
6. Make a note of the pressure indicated by the pressure gauge at that point. If the measured pressure differs by more than 2 mbar from the VPS set-up value, set the pressure switch to the correct value or replace it.

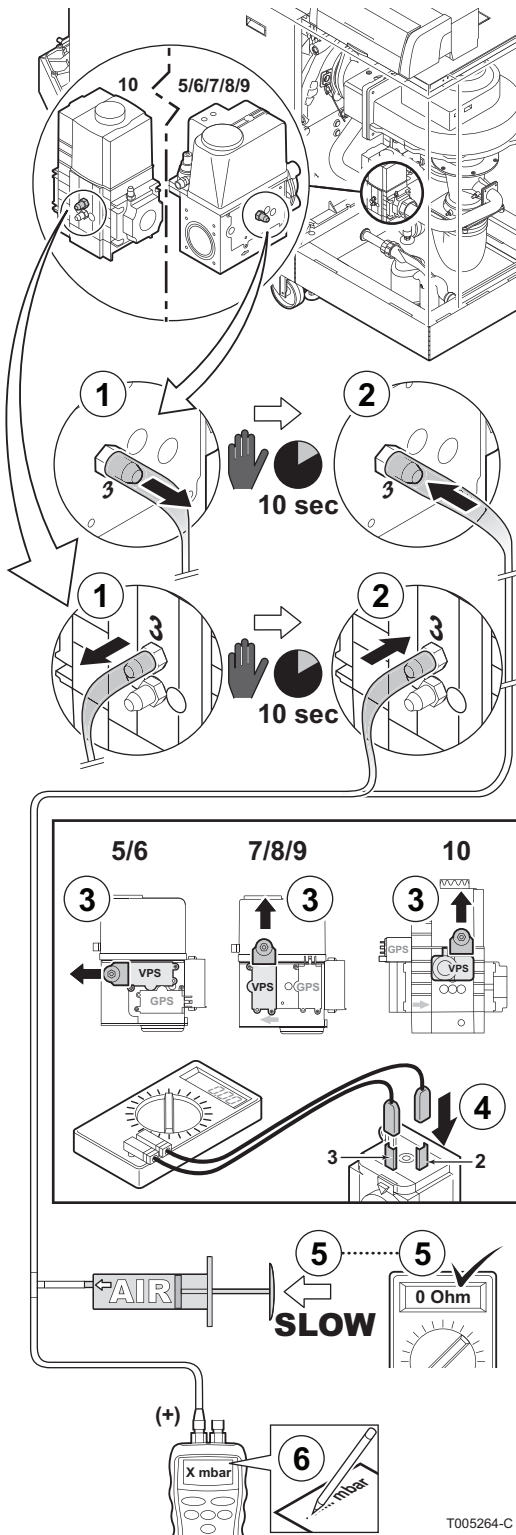

### 7.2.12. Check the minimum gas pressure switch Gps

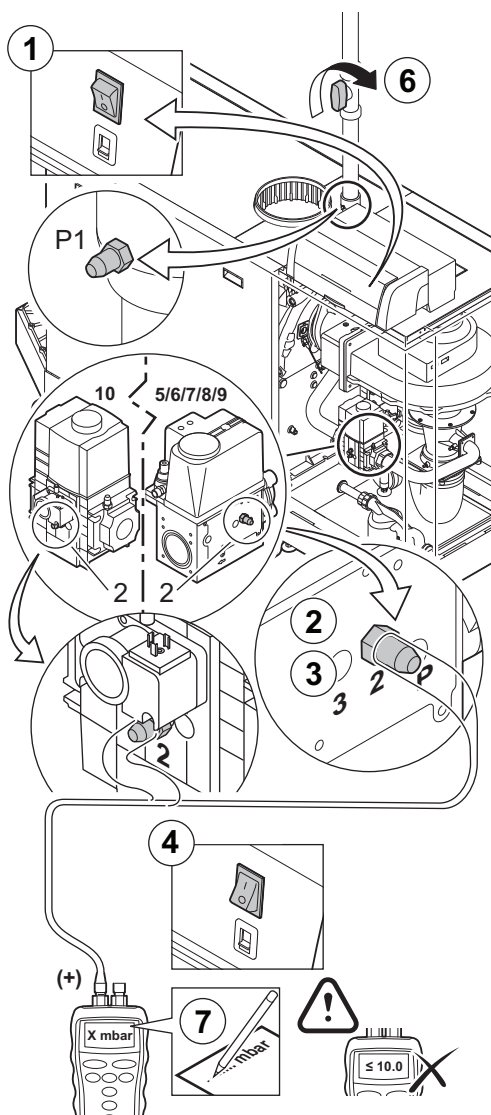

1. Switch the boiler off.
2. Open the screw in measuring point 2 of the gas block.
3. Connect a pressure gauge to measuring point 2 of the gas block.
4. Switch on the boiler.
5. Set the boiler to low load.
6. Close the boiler gas cock very slowly until the boiler shuts down;  
Code **5E:9**.
7. Make a note of the pressure indicated by the pressure gauge at that point. Compare the values measured with the checking values given in the table. If the measured pressure is lower, set the gas pressure switch to the correct value or replace it.

Pressure switch minimum	
Gas 310 ECO PRO	Minimum value
285	14 mbar
355	13 mbar
430	10 mbar
500	10 mbar
575	10 mbar
650	10 mbar

## 7.3 Specific maintenance operations



For work on the boiler **Gas 610 ECO PRO**: The features and instructions described are for each boiler module.



### CAUTION

During inspection and maintenance operations, always replace all gaskets on the parts removed.



After a service complete the checklist.

If the standard inspection and maintenance operations have revealed the necessity to carry out additional maintenance work, proceed as follows, depending on the nature of the work:



**DANGER**

- ▶ Disconnect the appliance's electricity supply.
- ▶ Shut off the gas supply.

We recommend carrying out the specific maintenance activities in the following order:

1. Clean the fan and the venturi.
2. Clean and inspect the non-return valve.
3. Replacing the ionization/ignition electrode.
4. Cleaning the gas filter.
5. Clean and inspect the burner.
6. Clean the burner area.
7. Cleaning the heat exchanger.
8. Cleaning the condensate collector.
9. Cleaning the siphon.
10. Assembling the boiler.
11. Put the boiler back into operation.

**7.3.1. Clean the fan and the venturi**

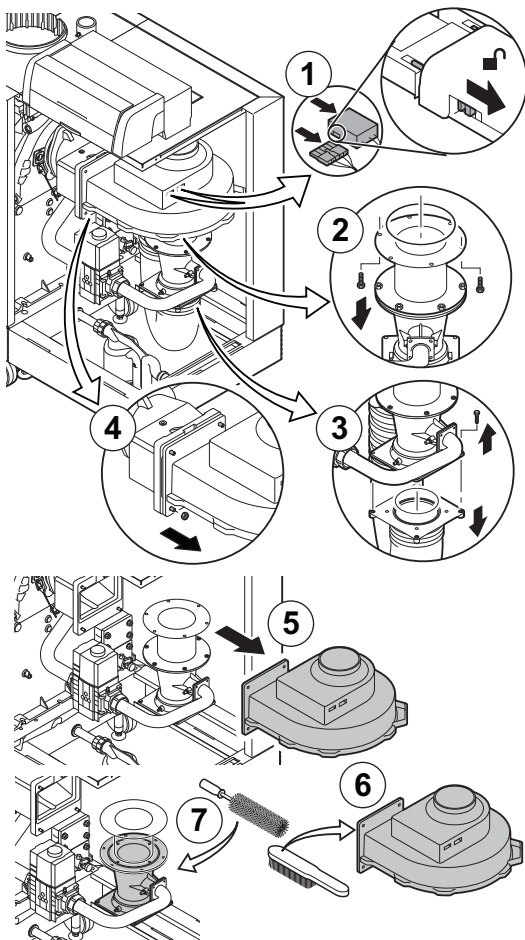

T003494-J

1. Remove the electrical connections from the fan. Push the safety slides on both sides of the power plug right to the back (You could use a small screwdriver for example).
2. Unscrew the bolts from the extension piece under the fan. Support the gas block, using a block of wood, for example.
3. Disconnect the air inlet hose from the venturi.
4. Unscrew the nuts on the fan output.
5. Disconnect the fan from the adapter.
6. Clean the fan with a soft plastic brush.
7. Clean the venturi with a soft plastic brush.

### 7.3.2. Clean and inspect the non-return valve

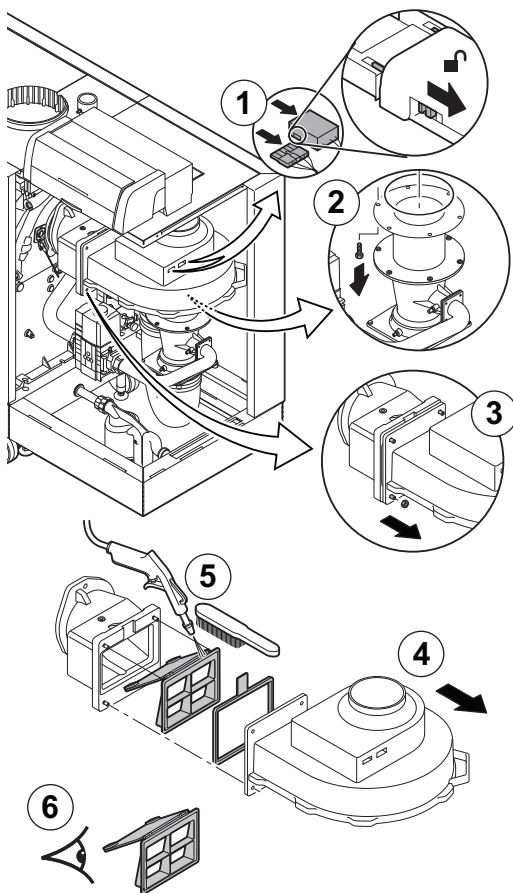

T003493-H

The non return valve must be replaced if it is faulty.

1. Remove the electrical connections from the fan. Push the safety slides on both sides of the power plug right to the back (You could use a small screwdriver for example). Support the gas block, using a block of wood, for example.
2. Unscrew the bolts from the extension piece under the fan.
3. Unscrew the nuts on the fan output.
4. Disconnect the fan from the adapter.
5. Clean the non-return valve with a soft plastic brush or with compressed air.
6. Inspect the non-return valve and replace it if faulty or seriously damaged.
7. To re-assemble, perform the above actions in reverse order.



#### CAUTION

Reconnect the fan's electrical connection.

### 7.3.3. Replacing the ionization/ignition electrode

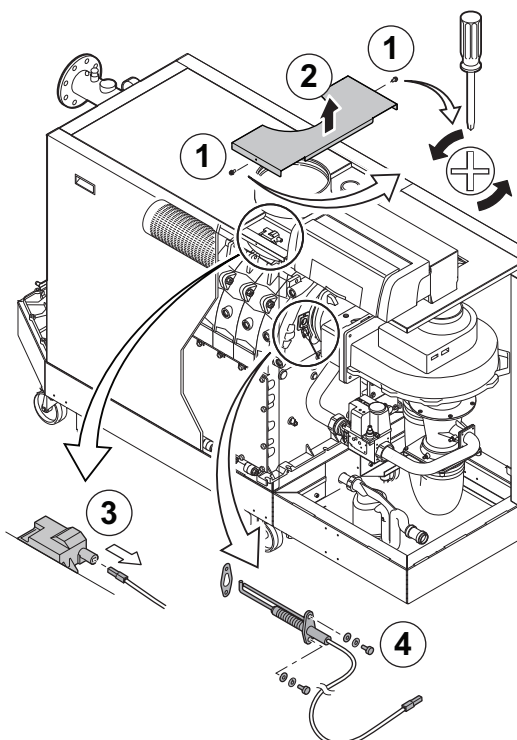

T003490-H

Replace the ionization/ignition electrode in the following cases:

- ▶ Ionization current  $< 3 \mu\text{A}$ .
- ▶ The electrode is damaged or worn (Visual inspection).

If replacement is necessary, proceed as follows:

1. Unscrew the 2 screws on the middle top casing.
2. Remove the middle top casing.
3. Remove the cable from the ionization/ignition electrode on the ignition transformer.
4. Unscrew the 2 screws and remove the ionization/ignition electrode.



#### CAUTION

Do not fit the new ionisation/ignition electrode until the burner has been cleaned and refitted. This will prevent damage occurring.

### 7.3.4. Cleaning the gas filter

**i** The 5 to 9 section boilers are supplied with a different gas block from the 10 section boiler.

1. Remove the gas filter.
2. Inspection.
3. Clean the gas filter without the use of liquids (shake it or carefully blow it clean).
4. Replace the gas filter if necessary.
5. To re-assemble, perform the above actions in reverse order.

**i** In this gas block, the gas filter holder has a positioning ridge. Position this at the top left during assembly.

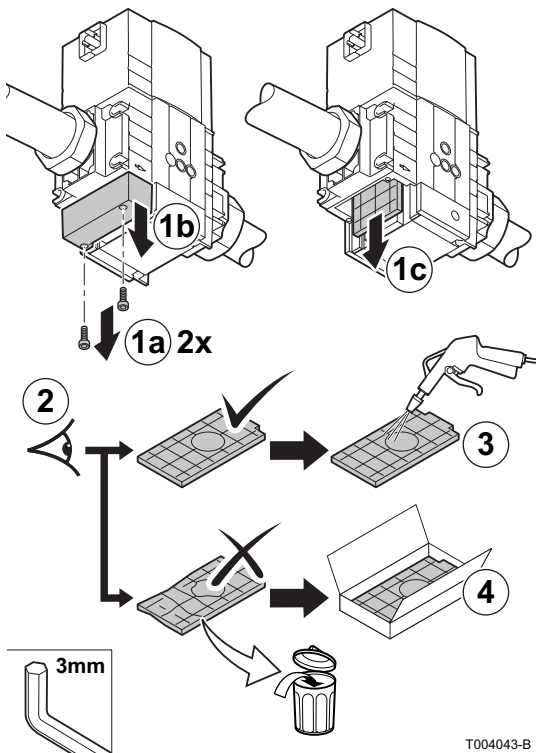
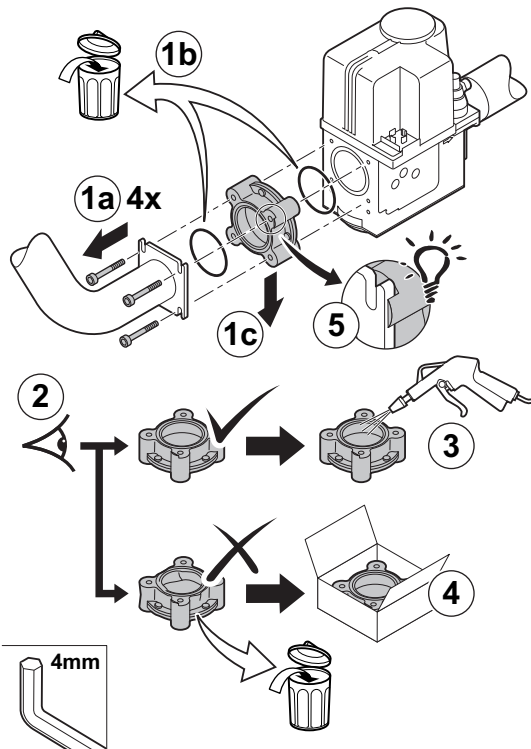

T004043-B

### 7.3.5. Cleaning the burner

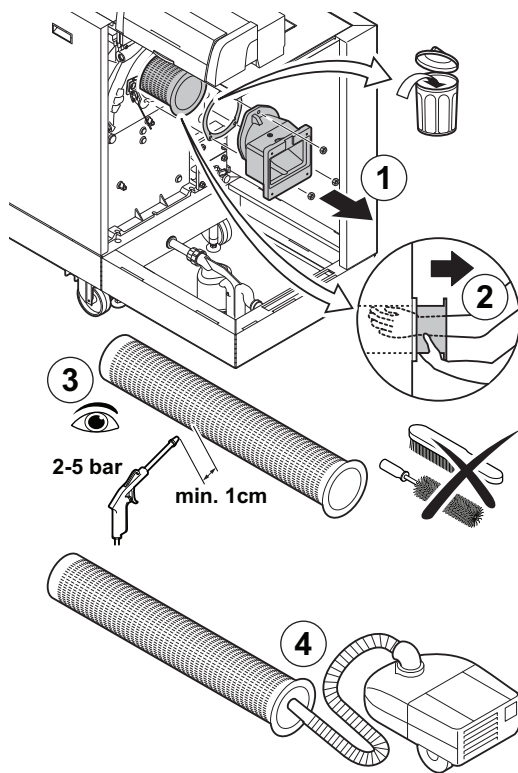

T003488-F

1. Unscrew the nuts from the adapter: Remove the adapter.
2. Lift the burner out of the heat exchanger.
3. Check the burner and, if necessary, clean without touching it (e.g. with compressed air between 2 and 5 bars: respect a minimum distance of 1 cm from the surface of the burner).



Never clean the burner's surface with a brush or similar item.

4. Carefully hoover the dirt from the inside of the burner.
5. Replace the burner if faulty or seriously damaged.



#### CAUTION

Do not refit the burner until the burner area, heat exchanger, condensate collector and siphon have been cleaned.

### 7.3.6. Clean the burner area

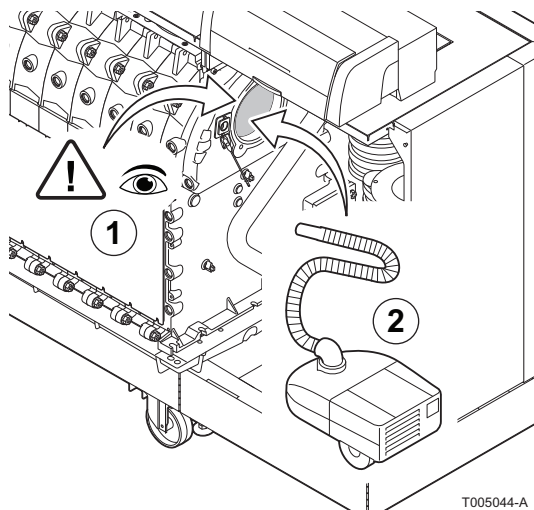

T005044-A

1. Perform a visual check of the burner area.
2. Remove visible pollution with a vacuum cleaner.

### 7.3.7. Checking the heat exchanger

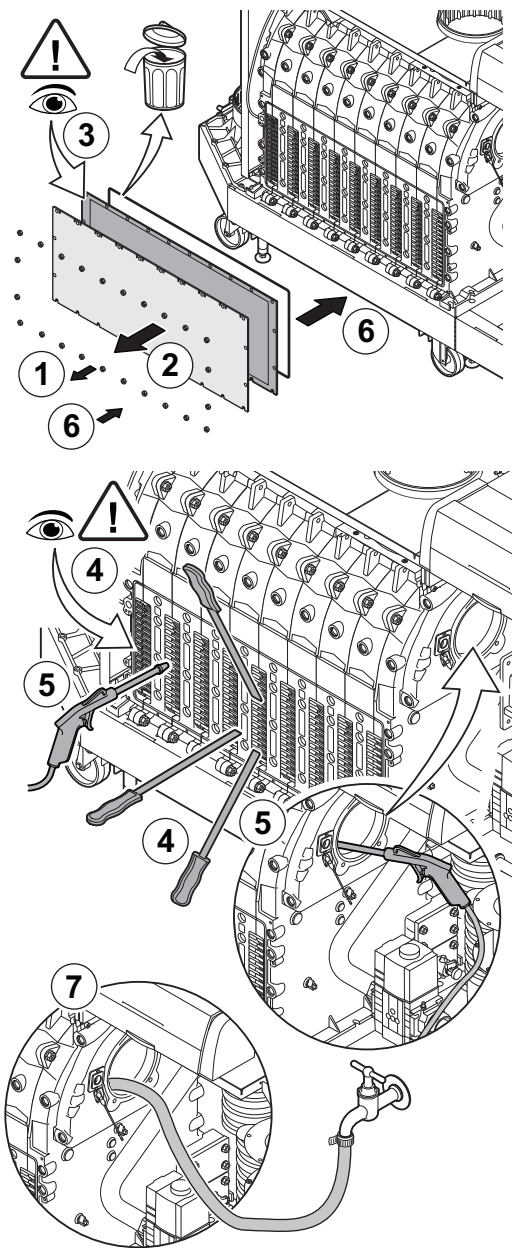

1. Unscrew the nuts from the inspection hatch on the heat exchanger.
2. Take the inspection hatch off the heat exchanger and remove the insulation cloth. The insulation cloth may stick to the heat exchanger. Avoid damaging or tearing the insulation cloth. Remove the silicon insulation cord.
3. Inspect the insulation cloth and replace if necessary.
4. Clean the areas between the pins of the heat exchanger using the special cleaning tool or cleaning knife (Accessory). Always work from the bottom to the top. Move the cleaning knife between the pins horizontally and diagonally.

**i** A range of cleaning knives is available for the various boilers. Always use the cleaning knife specially designed for this boiler. This knife has a length of 560 mm.

5. Use compressed air to blow the cleaned parts through in turn. Do this from the service side and from the burner area.
6. Fit the inspection hatch with the silicon cord and the insulation cloth.
7. Use clean water to thoroughly rinse the heat exchanger from the burner area.

T003491-G

### 7.3.8. Cleaning the condensate collector

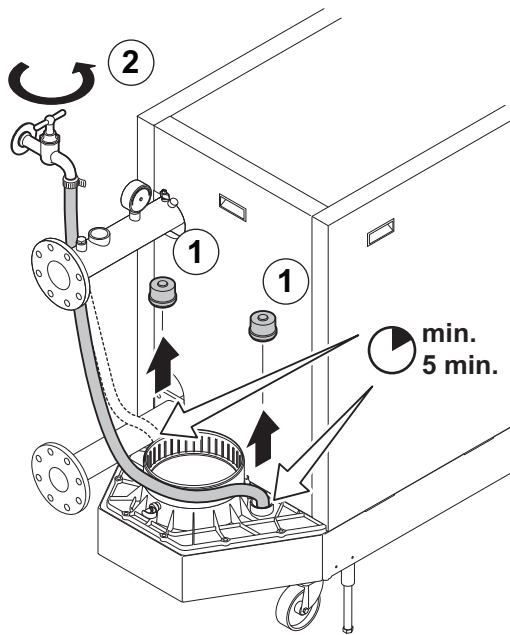

T004851-A

1. Remove both sealing caps from the condensate collector. (In front of and behind the flue gas discharge connection).
2. Thoroughly clean the condensate collector with water. Rinse each side of the condensate collector for at least 5 minutes with the largest possible water flow.
3. Refit both sealing caps on the condensate collector.

### 7.3.9. Cleaning the siphon

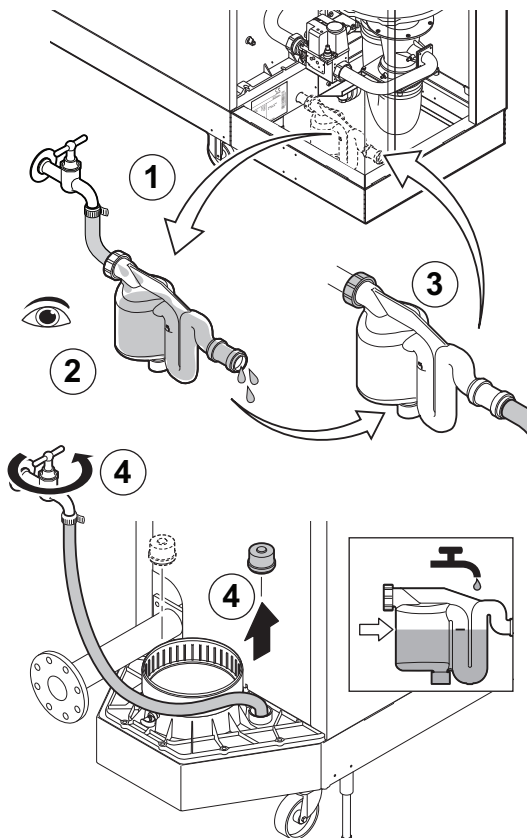

T003478-K

1. Remove the siphon.
2. Clean the siphon with water.
3. Put the siphon back in place.
4. Fill the siphon with water via the condensate tank (Up the level marker).

### 7.3.10. Assembling the boiler

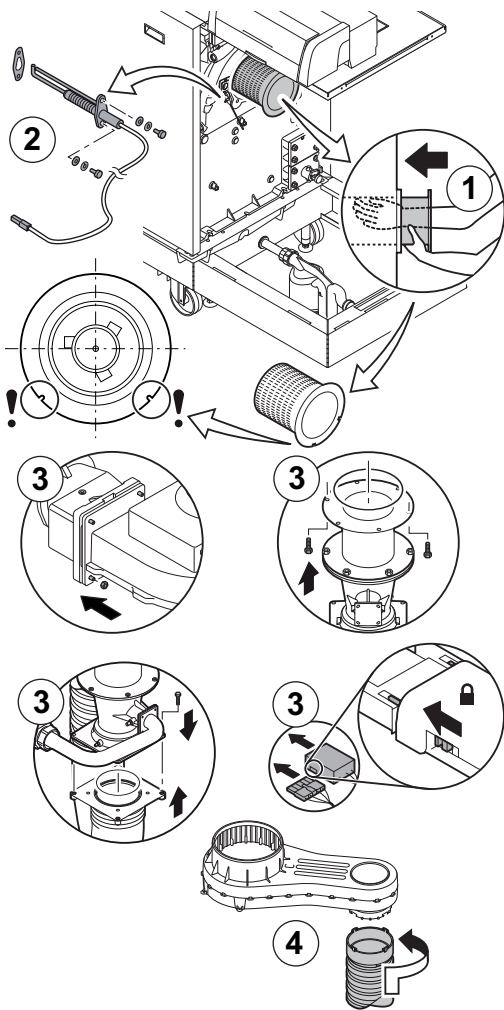

1. Fit the burner.



The burner has 2 holes at the front. Position it on the 2 support pins at the burner opening.

2. Fit the new ionisation/ignition electrode.
3. Fit the venturi and the fan.



#### CAUTION

Reconnect the fan's electrical connection.

4. Fit the air supply hose.



After a service complete the checklist.

T004857-C

### 7.3.11. Put the boiler back into operation

1. Open the main gas supply.
2. Check the gas circuit.
3. Checking the hydraulic pressure.
4. Check that there are no leaks on the hydraulic connections.
5. Checking the flue gas discharge and the air supply.
6. Check the electricity supply.
7. Check the electrical connections.
8. Turn on the boiler using the on/off switch.
9. Check the gas supply pressure at the pressure outlet P2 on the gas valve unit.
10. Check the ionization current.
11. Check the combustion.
12. Check the gas connections between the gas block and the venturi for tightness.
13. Bleed the Central Heating system.



After a service complete the checklist.

# 8 Troubleshooting

## 8.1 Shutdowns and lock-outs



For operation of the boiler **Gas 610 ECO PRO**: The features and instructions described are for each boiler module.

### 8.1.1. General

The boiler is fitted with an electronic regulation and control unit. The heart of the control system is a microprocessor, the **Comfort Master®**, which controls the boiler and also protects the boiler. When a failure is signalled, the boiler stops or becomes locked.

See the Installation and service manual **HMI GAS 310/610 ECO PRO** for comprehensive operating instructions. This includes information about changing and reading parameters, the meaning of fault codes and deleting the failure memory.

### 8.1.2. Blocking

A (temporary) blocking mode is a boiler operating function caused by an unusual situation. In this case, the display gives a code of blocking (code **5E:9**). The boiler control will try to re-start several times. The shutdown codes can be read out as follows

1. Press the two keys simultaneously.
2. Confirm by pressing key . **5E** is displayed, alternating with the shutdown code **9**.
3. Press the **[+]** key. **5U** appears on the display.



The boiler starts up again automatically when the reason for the blocking has been removed.

### 8.1.3. Lock out

When a failure is signalled, the boiler stops or becomes locked. The display shows :

**In a red flashing display:**

- ▶ The symbol
- ▶ The symbol **RESET**
- ▶ The fault code (for example **E:01**)

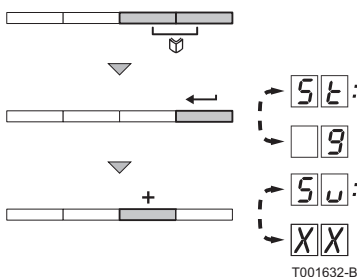



The boiler can only start operating again once the causes of the lock-out have been rectified and after pressing the **RESET** key

#### 8.1.4. Error memory

---

The boiler control is equipped with an error memory. The last 10 errors encountered are recorded in this memory. Each new input deletes the oldest entry from the memory. In addition to the error codes, the following data are also saved:

- ▶ Number of times that the error occurred: (n□:XX).
- ▶ Boiler operating mode selected (SE:XX).
- ▶ The flow temperature (E! :XX) and the return temperature (E2:XX) when the error occurred.



# 10 Checklists

## 10.1 Checklist for commissioning

No.	Work to be undertaken for commissioning	Confirmation / Measured values
1	Filling the central heating system with water and checking the water pressure	
2	Fill the siphon with water	
3	Vent the air in the heating system	
4	Checking the water-side connections for tightness	
5	Checking the type of gas supplied. Checking that the boiler is suitable for the gas supplied?	
6	Checking the gas supply pressure	
7	Checking the capacity of the gas meter	
8	Checking the tightness of the connections and the gas pipes	
9	Purge the gas supply pipe of the boiler	
10	Checking the electrical connections	
11	Checking the air supply connections and flue gas discharge connections	
12	Checking the functioning and operational status of the boiler	
13	Checking the air/gas ratio	
14	Remove the measuring device and close the measurement points	
15	Attaching the Gas Type sticker	
16	Reapply the casing on the inspection side	
17	Set the boiler regulation to the desired values	
18	Instruct the user and hand over the necessary documents	
19	Confirmation of commissioning	
	Date	(dd-mm-yy)
	Company name, signature of engineer	

## 10.2 Checklist for periodic inspection and maintenance

No.	Inspection and/or service activities	Confirmation and date				
1	Checking the hydraulic pressure					
2	Checking the ionization current					
3	Check the water quality					
4	Checking the air supply connections and flue gas discharge connections					
5	Checking the gas filter for pollution					
6	Checking combustion (CO <sub>2</sub> ) (Full load/Part load)					
7	Check the air supply hose					
8	Check the dirt trap					
9	Check the air box					
10	Check the air pressure differential switch <b>PS</b>					
11	Check the gas leakage control <b>VPS</b> (If installed)					
12	Check the minimum gas pressure switch <b>GPS</b> (If installed)					
13	Clean the fan and the venturi					
14	Clean and inspect the non-return valve					
15	Replacing the ionization/ignition electrode					
17	Cleaning the gas filter					
16	Clean and inspect the burner					
18	Clean the burner area					
19	Cleaning the heat exchanger					
20	Cleaning the condensate collector					
21	Cleaning the siphon					
22	Assembling the boiler (Replace all removed gaskets)					
23	Put the boiler back into operation					
24	Confirmation of inspection					
	Date	(dd-mm-yy)	(dd-mm-yy)	(dd-mm-yy)	(dd-mm-yy)	(dd-mm-yy)
	Company name, signature of engineer					







Remeha Commercial UK - Part of the BDR THERMEA  
Remeha House  
Molly Millars Lane  
Wokingham  
Berks  
RQ41 2QP

After Sales Tel: 01189743076  
Technical Enquires: 01189743067

Internet: [www.remeha.co.uk](http://www.remeha.co.uk)



© Copyright

All technical and technological information contained in these technical instructions, as well as any drawings and technical descriptions supplied, remain our property and shall not be multiplied without our prior consent in writing.

160514



 **remeha**

The Remeha logo is located at the bottom right of the page. It features a stylized 'R' symbol inside a square frame, followed by the word 'remeha' in a bold, lowercase, sans-serif font.