

It's Under Control®

# U2

Weather Resistant Remote Control

## Operation Guide



Copyright © 2008  
Remote Technologies Incorporated  
All rights reserved.

## FEDERAL COMMUNICATIONS COMMISSION NOTICE

This equipment has been tested and found to comply with the limits for a Class B digital device, pursuant to Part 15 of the FCC Rules. These limits are designed to provide reasonable protection against harmful interference in a residential installation.

This equipment generates, uses, and can radiate radio frequency energy and, if not installed and used in accordance with the instructions, may cause harmful interference to radio communications. However, there is no guarantee that interference will not occur in a particular installation.

If this equipment does cause harmful interference to radio or television reception, which can be determined by turning the equipment off and on, the user is encouraged to try to correct the interference by one or more of the following measures:

- Reorient or relocate the receiving antenna.
- Increase the separation between the equipment and the receiver.
- Connect the equipment into an outlet on a circuit different from that to which the receiver is connected.
- Consult the dealer or an experienced radio/TV technician for help.

This device complies with Part 15 of the FCC Rules. Operation is subject to the following two conditions:

1. This device may not cause harmful interference.
2. This device must accept any interference received including interference that may cause undesired operation.



**Canada IC = 3166A-RTI1200**



### DECLARATION OF CONFORMITY (DOC)

The Declaration of Conformity for this product can be found on the RTI website at: [www.rticorp.com/declaration](http://www.rticorp.com/declaration)

## BATTERY DISPOSAL



Your U2 Weather Resistant Remote Control is shipped with non-rechargeable primary batteries. These batteries are generally considered not to be environmentally hazardous. In most cases they can be disposed of in normal household trash, but you should always verify and follow your local regulations.

Do not burn or incinerate used batteries, as it may cause internal materials to explode.

It is important not to dispose of large amounts of batteries in a group. Used batteries are often not completely “dead.” Grouping used batteries together can bring these “live” batteries into contact with one another, creating safety risks.

## SAFETY SUGGESTIONS

**Read Instructions.** Read all safety and operating instructions before operating the unit.

**Retain Instructions.** Keep the safety and operating instructions for future reference.

**Heed Warnings.** Adhere to all warnings on the unit and in the operating instructions.

**Follow Instructions.** Follow operating instructions and instructions for use.

**Heat.** Keep the unit away from heat sources such as radiators, heat registers, stoves, etc., including amplifiers that produce heat.

**Object Entry.** Do not allow objects to fall into the enclosure through openings.

**Servicing.** Do not attempt any service beyond that described in the operating instructions. Refer all other service needs to qualified service personnel.

**Damage Requiring Service.** The unit should be serviced by qualified service personnel when:

- Objects have fallen into the unit.
- The unit does not appear to operate normally or exhibits a marked change in performance.
- The unit has been dropped or the enclosure has been damaged.

## LIMITED WARRANTY AND DISCLAIMER

Remote Technologies Incorporated warrants its products for a period of one (1) year from the date of purchase from Remote Technologies Incorporated or an authorized Remote Technologies Incorporated distributor.

This warranty may be enforced by the original purchaser and subsequent owners during the warranty period, so long as the original dated sales receipt or other proof of warranty coverage is presented when warranty service is required.

Except as specified below, this warranty covers all defects in material and workmanship in this product. The following are not covered by the warranty:

Damage resulting from:

1. Accident, misuse, abuse, or neglect.
2. Failure to follow instructions contained in this Guide.
3. Repair or attempted repair by anyone other than Remote Technologies Incorporated.
4. Failure to perform recommended periodic maintenance.
5. Causes other than product defects, including lack of skill, competence or experience of user.
6. Shipment of this product (claims must be made to the carrier).
7. Being altered or which the serial number has been defaced, modified or removed.

Remote Technologies Incorporated is not liable for any damages caused by its products or for its failure of its products to perform, including any lost profits, lost savings, incidental damages, or consequential damages.

Remote Technologies Incorporated is not liable for damages based upon inconvenience, loss of use of the product, loss of time, interrupted operation, commercial loss, any claim made by a third party or made by you for a third party.

Remote Technologies Incorporated's liability for any defective product is limited to repair or replacement of the product, at our option.

If your U2 Weather Resistant Remote Control needs service, please contact Remote Technologies Incorporated by telephone, fax or E-mail for return information. **Please do not return products to Remote Technologies Incorporated without return authorization.**

All rights are reserved. No part of this document may be photocopied, reproduced, or translated without the prior written notice of Remote Technologies Incorporated.

The information contained in this document is subject to change without notice. Remote Technologies Incorporated shall not be liable for errors or omissions contained herein or for consequential damages in connection with the furnishing, performance, or use of this guide.

Microsoft and Windows are registered trademarks of Microsoft Corporation. Other brands and their products are trademarks or registered trademarks of their respective holders.

U2, *Integration Designer*™, and the RTI logo are registered trademarks™ of Remote Technologies Incorporated.



## TABLE OF CONTENTS

<b>Federal Communications Commission Notice.....</b>	<b>3</b>
<b>Battery Disposal.....</b>	<b>4</b>
<b>Safety Suggestions.....</b>	<b>4</b>
<b>Limited Warranty and Disclaimer .....</b>	<b>5</b>
<b>Table of Contents .....</b>	<b>7</b>
<b>Chapter 1 - Welcome .....</b>	<b>9</b>
Compatibility.....	9
Software Requirements .....	9
Unpacking and Inspection .....	10
Product Contents .....	10
<b>Chapter 2 - Introduction.....</b>	<b>11</b>
Features .....	11
Important Notes .....	11
Waterproof Note .....	11
Getting Started .....	12
Cleaning .....	12
Remote Reference.....	13
<b>Chapter 3 - Operation.....</b>	<b>15</b>
LCD Display .....	15
Control Panel Page.....	16
Adjust Contrast .....	16
Time Out .....	17
Tilt Switch.....	17
Change Passcode .....	18
Clear All .....	19
Low Battery Indicator .....	19
Programming .....	19
<b>Chapter 4 - Specifications.....</b>	<b>21</b>
<b>Chapter 5 - Troubleshooting.....</b>	<b>23</b>
<b>Chapter 6 - Service and Support.....</b>	<b>25</b>
<b>Index .....</b>	<b>27</b>





## CHAPTER 1 | WELCOME

### **Thank you for purchasing the U2 Weather Resistant Remote**

**Control.** The U2 Weather Resistant Remote Control is designed for reliable wireless control of audio/video systems from environments which are too harsh for normal remote controls. It is completely sealed, making it waterproof\*. The U2 combines the convenience of eight programmable "soft" buttons with an LCD display and the ideal selection of commonly used keypad buttons. The high contrast display can be customized with any combination of text and graphics desired. This provides a simple and flexible interface for operating today's sophisticated electronic systems, regardless of the location. The U2 Weather Resistant Remote Control is a perfect companion for hot tubs, pools, bathrooms, and decks.

Used with RTI automation devices, the U2 Weather Resistant Remote Control is capable of power sensing for reliable operation and RS-232 communications for advanced control. Sleek and durable, the U2 expands your control to wherever your lifestyle requires.

### **COMPATIBILITY**

The U2 Weather Resistant Remote Control is capable of radio frequency output only and must be installed along with an RTI control processor and RF antenna - it cannot deliver IR directly to devices. RTI control processors and *Integration Designer™* software are compatible with infrared (IR) commands with carrier frequencies between 15KHz and 460KHz, as well as those commands that do not use a carrier. This covers virtually all of the remotes that exist to date.

### **SOFTWARE REQUIREMENTS**

The recommended minimum system requirements needed to run the *Integration Designer™* software are as follows:

- Windows 2000®, Windows XP® or later version.
- A free USB port.
- At least 256 Megabytes of RAM.
- At least 250 Megabytes of free disk storage.
- Screen resolution of 800x600 with 16-bit color.
- Optional printer for printing reports.

## CHAPTER 1 | WELCOME

### UNPACKING AND INSPECTION

After unpacking your new U2 Weather Resistant Remote Control, save all of the packing materials in case you ever have to ship the unit.

Thoroughly inspect the U2 and packing materials for signs of damage. Report any damage to the carrier immediately. Report any equipment malfunctions to Remote Technologies Incorporated or an authorized Remote Technologies Incorporated distributor.

### PRODUCT CONTENTS

Contents within the box include the following items:

- One (1) U2 Weather Resistant Remote Control
- One (1) mounting holster
- Four (4) AAA batteries
- One (1) operation guide
- Two (2) wood screws

## CHAPTER 2 | INTRODUCTION

### FEATURES

The U2 Weather Resistant Remote Control provides superior quality and reliability as well as these features:

- Ergonomic design permits effortless, one-handed operation.
- Durable design is waterproof.\*
- Mounting holster included for storage when not in use.
- Thirty-three assignable/programmable keypad buttons.
- Combines easy-to-read LCD display for custom buttons, text, and graphics with eight programmable keypad buttons.
- Tactile feedback on all buttons.
- Transmits commands using RF for operation through walls, cabinets, etc.
- Optional 'Voltage' and 'Video' sensing modules to monitor power status of equipment.
- Optional interface for RS-232 controlled equipment.
- Non-volatile Flash memory stores your system configuration even when power is not present.
- Field upgradable firmware.
- System includes four AAA batteries.
- USB Programming.

### IMPORTANT NOTES

Please read these important notes about the U2 Weather Resistant Remote Control:

- The U2 performs optimally in temperatures between 40° F to 105° F. If the temperature is too hot, the display appears dim. If the temperature is too cold, the display appears dark and may respond slowly.
- Do not subject the U2 to vibrations. The display may be damaged from excessive shock or vibration.
- Do not disassemble the unit - Do not remove the screws holding the back cover of the U2. Service of the U2 Weather Resistant Remote Control should be performed by authorized personnel only.
- If the U2 is subjected to harsh chemicals such as chlorine or salt water, rinse the remote in fresh water with mild detergent to prevent cosmetic or other damage.

### \*WATERPROOF NOTE

The U2 Weather Resistant Remote Control is designed to withstand temporary exposure to water only. Although it is safe to use in showers, hot tubs, and pools, **DO NOT ALLOW THE U2 WEATHER RESISTANT REMOTE CONTROL TO REMAIN FLOATING OR SUBMERGED IN WATER FOR AN EXTENDED PERIOD OF TIME.** A mounting holster is provided for storage when the U2 is not in use.

## CHAPTER 2 | INTRODUCTION

### GETTING STARTED

**NOTE:** The following steps for initial installation including removing/ installing the battery door should be performed by an authorized service center or trained installer only.

### BATTERIES

Start by inserting four AAA batteries (included) into the battery compartment. Make sure they are oriented properly. A polarity diagram is molded into the bottom of the battery compartment.

**IMPORTANT NOTE:** When replacing batteries it is recommended that Lithium batteries be used as they provide a greater lifespan.

### PROGRAMMING

Pull up the USB Programming Port Cover inside the battery compartment to allow access to the USB programming port. Insert the USB cable into the programming port and download the configuration file using the Integration Designer™ software.

### BATTERY COMPARTMENT DOOR INSTALLATION

If you are replacing old batteries, you will need to first remove the seven screws that hold the battery compartment door in place.

**IMPORTANT NOTE:** DO NOT REMOVE THE ELEVEN SCREWS HOLDING THE TOP AND BOTTOM OF THE U2 TOGETHER.

**ADDITIONAL NOTE:** PRIOR TO INSTALLING THE BATTERY COMPARTMENT DOOR, VERIFY THAT THE RUBBER BATTERY COMPARTMENT GASKET AND USB PROGRAMMING PORT COVER ARE ALIGNED AND INSTALLED PROPERLY.

In order to simplify the initial programming process, the U2 is shipped without the seven battery compartment screws tightened. When tightening these screws, make sure the pressure is evenly distributed around the entire outer gasket. You should gradually tighten each screw, rotating among them around the unit (similar to tightening the bolts on a spare tire). Each screw should eventually be tightened firmly, but not over-tightened.

The U2 is turned on by touching any keypad button. If the tilt sensor is enabled, picking up the unit will also turn it on.

### CLEANING

Occasional cleaning may be required, depending on use. To clean your U2, lightly dampen a lint-free cloth with fresh water and mild detergent, and wipe the display, keypad and outer surfaces. Rinse with fresh water.

## CHAPTER 2 | INTRODUCTION

### BACK

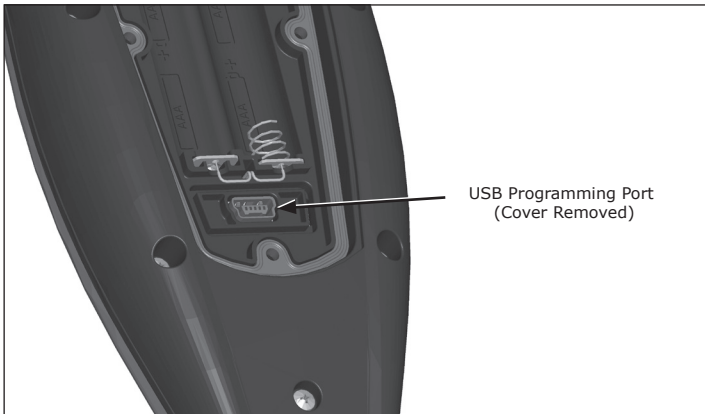
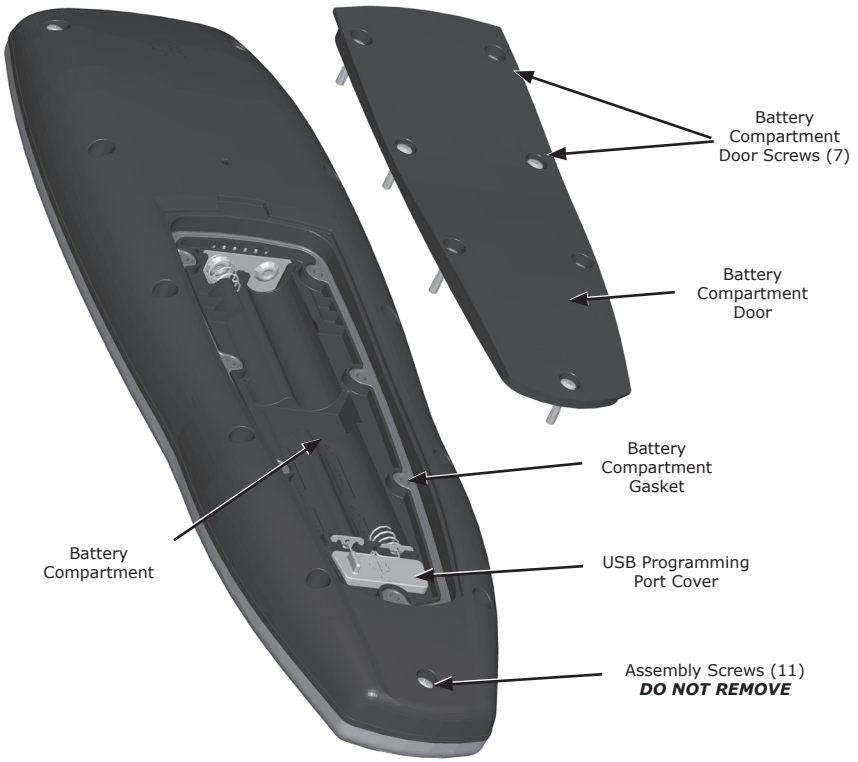

### CHAPTER 2 | INTRODUCTION

#### FRONT

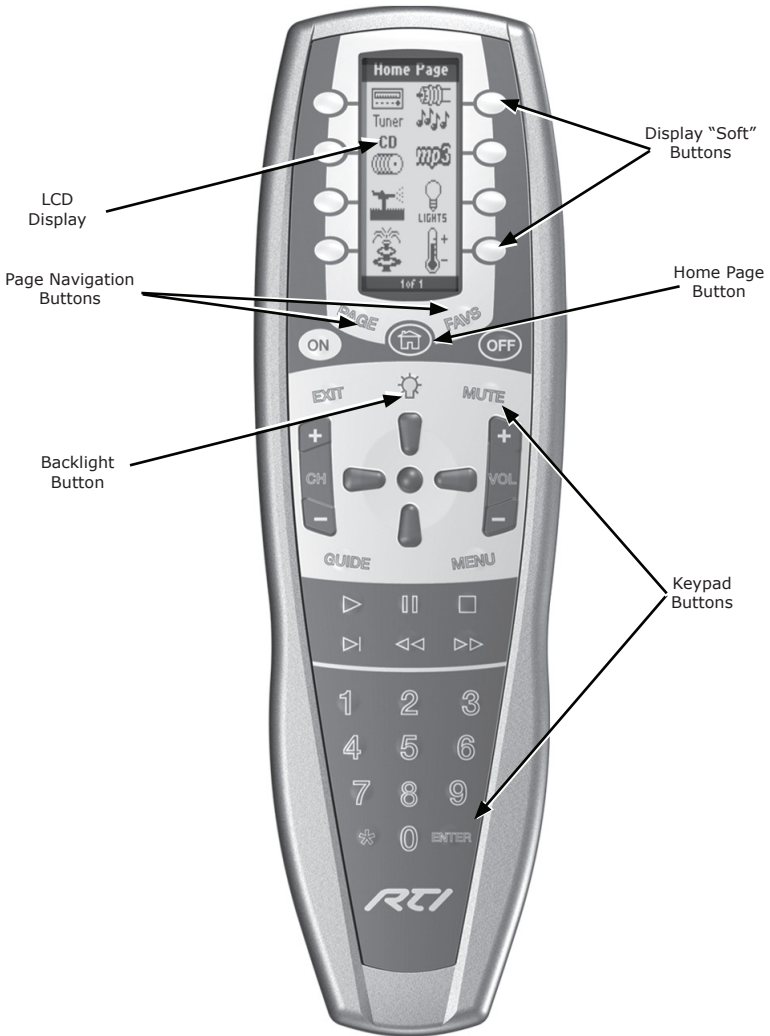

## CHAPTER 3 | OPERATION

### THE LCD DISPLAY

The U2 Weather Resistant Remote Control display is organized as a series of pages and frames. A page consists of one to nine frames, and only one frame is displayed on the screen at a time.

Normally each frame on a page contains objects (text, graphics, etc.) that are related in some way. For instance, they may all display information necessary for controlling a particular DVD player.

By default, the U2 has one Home page—all other pages are normally accessed from links on the Home page. In addition, any button on any page can contain a link to any other page when selected.

Normally the Home page is used to display the names of the equipment being controlled. The U2 Weather Resistant Remote Control will support 200 pages including the Home page; each page can consist of up to 9 frames.

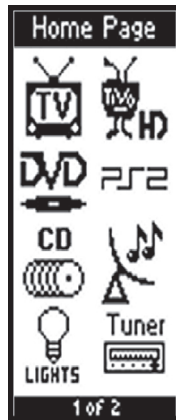

By default, pressing the HOME button at any time will return you to this page. It is possible, however, to program the Home button to behave differently if desired.

## CHAPTER 3 | OPERATION

### THE CONTROL PANEL PAGE

The Control Panel page can be displayed by holding down the backlight button for three seconds.

You can also access the Control Panel page by assigning a "Control Panel" page link to a button using the *Integration Designer™* software.

The Control Panel consists of the following two frames:

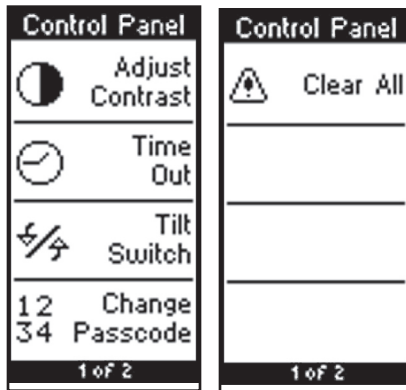

To change frames, press the next page button below the display.

To return to the user program, press the Home button.

### ADJUST CONTRAST

This selection displays a window that allows you to adjust the LCD contrast. Press the Left Arrow or Right Arrow soft buttons to adjust. Press either of the OK soft buttons to close.

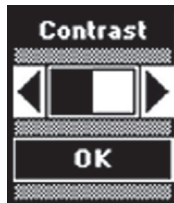



## CHAPTER 3 | OPERATION

### TIME OUT

This selection displays a window that allows you to adjust the amount of time the unit stays awake after the last button press. The time is variable from 1 second to 60 seconds. Press the Left Arrow or Right Arrow soft buttons to adjust the time.

Note: The default time out is 10 seconds, changing this time may shorten the battery life of the U2.

Press either of the OK soft buttons to close.



### TILT SWITCH

This selection displays a window that allows you to adjust the settings for the built-in tilt switch. The tilt switch is a motion detector that turns the remote on when activated.

**On** means the tilt switch is active and will wake up the U2 Weather Resistant Remote Control when it is moved.

**Off** means the tilt switch is inactive.

Press either of the OK soft buttons to close.

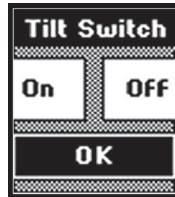

## CHAPTER 3 | OPERATION

### CHANGE PASSCODE

This selection displays a window that allows you to set the passcode that is used to limit access to the Clear All function in the Control Panel, as well as the Secured property that can be assigned to any button.

When you select the CHANGE PASSCODE function, the screen will prompt you to enter the old passcode using the numeric keypad buttons. Press the ENTER keypad button after entering the numbers.

(The default code is 0000).



Now enter a new four-digit passcode.



You will be prompted to enter the new four-digit passcode again for confirmation.

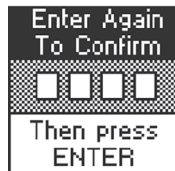

When new code is entered successfully, the "Code Changed" window will pop up to let you know you have changed the passcode.



**Do not forget the passcode!**

## CHAPTER 3 | OPERATION

### CLEAR ALL

This selection displays a window that will allow you to erase the current user program in the U2 Weather Resistant Remote Control. You will be prompted to enter the current passcode. If the proper code is entered, the entire user program in the U2 will be erased.

**Warning!** This will erase the entire user program in the U2. Once this is done there is no way to restore it, except by reloading the program from the *Integration Designer*™ software!

If you inadvertently select the CLEAR ALL function, simply press the ENTER keypad button without entering the passcode and you will be returned to the Control Panel page.

### LOW BATTERY INDICATOR

If the U2 Weather Resistant Remote Control battery capacity is reduced to approximately 25 percent, a low battery icon will appear in the lower left side of the display:

At this point the U2 batteries should be replaced to maintain optimum performance.

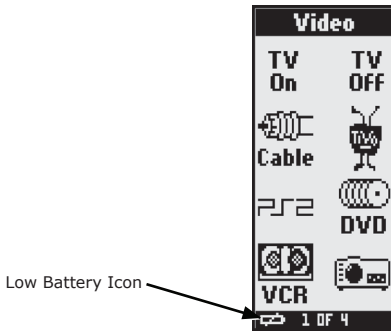

## PROGRAMMING THE U2 WEATHER RESISTANT REMOTE CONTROL

The U2 Weather Resistant Remote Control is programmed using RTI's *Integration Designer*™ software. RTI dealers can download the software from:

[www.rticorp.com/dealers](http://www.rticorp.com/dealers)

A PC running Windows® 2000 or higher with a USB port is required. The required USB cable is included with the RTI IR-PRO dealer kit.

**Note:** The U2 will not operate normally while connected to a PC's USB port. Make sure you disconnect it from the PC to navigate pages or transmit commands. In addition, the U2 will not be able to sync with a PC's USB port while it is transmitting a command or running a macro.



## CHAPTER 4 | SPECIFICATIONS

Power	4 - AAA batteries
Power Management	Automatic On/Off (tilt switch)
Radio Frequency Control Range	Up to 100 feet (30.5 meters) with System Interfaces/Processors
Radio Frequency Carrier	433 MHz
Operating Temperature	+32° F to +122° F (0° C to +50° C)
Display	High-contrast STN Monochrome LCD 128h x 64w pixels
Display Size (H x W)	2.1 in x .94 in (53mm x 24mm)
Backlights	White EL (Display and Keypad)
Total System Memory	256K Bytes Flash (non-volatile) memory
Device Capability	Total number of devices is limited only by memory
Macro Capability	Unlimited steps in a single macro Total number of macros is limited only by memory Macro capability on every button
Communications	USB programming port
Dimensions (L x W x D)	9.1" (231mm) x 2.4" (61mm) x 1.0" (25mm)
Enclosure	High-impact molded ABS plastic
Weight	7 oz. (200g)
Warranty	One Year (Parts & Labor)

All specifications subject to change without notice.



## CHAPTER 5 | TROUBLESHOOTING

If you are having problems with your U2 Weather Resistant Remote Control, please read the information below before contacting technical support.

If you continue to have problems, see Chapter 6 for more information on contacting RTI technical support.

### **DISPLAY IS DIM, BLANK OR UNREADABLE**

- Make sure the batteries are inserted properly and are new. Try adjusting the contrast level from the Control Panel page (Refer to Chapter 3 for more details). By nature, the contrast of an LCD screen changes with temperature, so if the remote is cold the display will be dark and will return to normal as it warms.

### **USB COMMUNICATIONS PROBLEMS**

- Verify that your PC is running Windows® 2000 or higher.
- Verify that the U2 Remote Control is present in the Human Interface Devices section of the Device Manager within the Windows® Control Panel.
- Make sure you are using the programming cable that was supplied by RTI and that both ends are connected securely.
- Make sure the PC detects the presence of the U2 Remote Control. If it doesn't, unplug the USB cable, wait for about ten seconds, and plug it in again.
- If the download fails after some data has been transferred, try re-sending the program.

### **CONTROL PROBLEMS**

- If you are using an RTI RF control system, look at the data light on the RTI RF antenna - a green light denotes an RTI signal is being received, while a red light means there is some interference blocking the signal.
- Verify the USB programming cable is disconnected.





## **CHAPTER 6 | SERVICE AND SUPPORT**

For news about the latest updates, new product information, and new accessories, please visit our web site at:

[www.rticorp.com](http://www.rticorp.com)

### **CONTACTING RTI**

For general info, you can contact RTI at:

Tel. (952) 253-3100

Fax (952) 253-3131

[info@rticorp.com](mailto:info@rticorp.com)

### **RTI TECHNICAL SUPPORT**

At RTI, customer service and satisfaction is an utmost priority. If you are encountering any problems or have a question about your RTI product, please contact RTI Technical Support for assistance.

RTI provides technical support by telephone, fax or e-mail. For the highest quality service, please have the following information ready, or provide it in your fax or e-mail.

- Your Name
- Company Name
- Telephone Number
- E-mail Address
- Product model and serial number (if applicable)

If you are having a problem with hardware, please note the equipment in your system, a description of the problem, and any troubleshooting you have already tried.

If you are having a problem with software, please note what version you have installed, the operating system on your PC, a description of the problem, and any troubleshooting you have already tried.

If you are calling about a software or programming question or problem, please be at you computer when you place your call. This will considerably speed up the troubleshooting process.

For technical support or assistance with your U2 Weather Resistant Remote Control, software, or accessories, contact RTI at:

(952) 253-3137

[support@rticorp.com](mailto:support@rticorp.com)

[www.rticorp.com](http://www.rticorp.com)

For questions regarding service or repair of your U2 Weather Resistant Remote Control, contact RTI at:

(952) 253-3136

[service@rticorp.com](mailto:service@rticorp.com)

[www.rticorp.com](http://www.rticorp.com)

**Please do not return products to RTI without return authorization.**

## CHAPTER 6 | SERVICE AND SUPPORT

### Shipment of U2 Weather Resistant Remote Control for Service

RTI will pay all labor and material expenses for all repairs covered by this product's warranty. If necessary repairs are not covered by warranty, or if a unit is examined which is not in need of repair, you may be charged for the repairs or examination.

If it is necessary to ship the U2 Remote Control for service:

- Please pack it securely (we suggest that it be insured).
- Do not include accessories such as power cords or manuals unless instructed to do so.

You must pay any shipping charges incurred in getting your U2 Weather Resistant Remote Control to RTI. RTI will pay reasonable return shipping charges via a carrier of our choice to any destination within the United States if the repairs are covered under warranty.

A copy of the original dated sales receipt must be provided whenever warranty service is required. You will need this receipt to establish the date of purchase.

**INDEX**

Battery Disposal .....	4
Table of Contents.....	7
Features.....	11
Federal Communications Commission Notice .....	3
Introduction.....	11
Important Notes.....	11
Waterproof Note.....	11
Cleaning .....	12
Getting Started .....	12
Remote Reference .....	13
Limited Warranty/Disclaimer .....	5
Operation .....	15
Adjust Contrast.....	16
Change Passcode .....	18
Clear All.....	19
Control Panel Page .....	16
LCD Display.....	15
Low Battery Indicator .....	19
Programming.....	19
Tilt Switch .....	17
Time Out.....	17
Product Contents.....	10
Safety Suggestions .....	4
Service and Support .....	25
Contact RTI .....	25
Shipment for Service .....	26
Technical Support.....	25
Specifications.....	21
Troubleshooting.....	23

*It's Under Control®*



**Remote Technologies Incorporated**  
**5775 12th Avenue East, Suite 180**  
**Shakopee, MN 55379**  
**Tel: 952-253-3100**  
**Fax: 952-523-3131**  
**[www.rticorp.com](http://www.rticorp.com)**