

RMI-Q radio machine interface



© 2012 Renishaw plc. All rights reserved.

This document may not be copied or reproduced in whole or in part, or transferred to any other media or language, by any means, without the prior written permission of Renishaw plc.

The publication of material within this document does not imply freedom from the patent rights of Renishaw plc.

Renishaw part no: H-5687-8504-01-A

First issued: **BETA SITE ONLY**

Contents

Contents

Before you begin	1.1
Before you begin	1.1
Disclaimer	1.1
Trademarks	1.1
Warranty	1.1
Changes to equipment	1.1
CNC machines	1.1
Care of the RMI-Q	1.1
RMP probe family	1.2
Patents	1.2
EC declaration of conformity	1.3
WEEE directive	1.3
FCC information to the user (USA only)	1.3
Radio approval	1.4
Radio equipment - Canadian warning statements	1.4
Radio approvals	1.4
Safety	1.5
RMI-Q basics	2.1
Introduction	2.1
Power supply	2.1
Input voltage ripple	2.1
RMI-Q visual diagnostics	2.2
P1, P2, P3, P4 SYSTEM STATUS LEDs	2.3
LOW BATTERY / START LED	2.3
PROBE STATUS LED	2.3
ERROR LED	2.3
SIGNAL LED	2.3

- RMI-Q inputs 2.4
- RMI-Q output waveforms. 2.6
- RMI-Q seated start option. 2.7
- Switches SW1 and SW2 2.8
 - Switch SW1 output configuration 2.8
 - Switch SW2 output configuration 2.9
- Remote external audible output 2.11
- RMI-Q dimensions. 2.12
- RMI-Q specification 2.13
- System installation..... 3.1**
 - Mounting bracket (optional). 3.1
 - Wiring diagram (with output groupings shown). 3.2
 - RMP - RMI-Q partnership 3.3
 - To partner the RMP with the RMI-Q. 3.3
 - To partner up to four RMPs with the RMI-Q without ReniKey 3.4
 - Partnering RMPs using ReniKey (Recommended) 3.5
 - Removing the RMP from the RMI-Q 3.5
 - Changing RMP position 3.5
 - RMI-Q cable 3.6
 - Cable sealing 3.6
 - Fitting flexible conduit. 3.6
 - Screw torque values 3.7
- Maintenance..... 4.1**
 - RMI-Q cover 4.1
 - Removing the RMI-Q cover 4.1
 - Replacing the RMI-Q cover 4.2
 - Side exit to rear exit cable conversion 4.2
- Fault finding 6.1**
- Parts list 7.1**

Before you begin

Before you begin

Disclaimer

RENISHAW HAS MADE CONSIDERABLE EFFORTS TO ENSURE THE CONTENT OF THIS DOCUMENT IS CORRECT AT THE DATE OF PUBLICATION BUT MAKES NO WARRANTIES OR REPRESENTATIONS REGARDING THE CONTENT. RENISHAW EXCLUDES LIABILITY, HOWSOEVER ARISING, FOR ANY INACCURACIES IN THIS DOCUMENT.

Trademarks

RENISHAW and the probe symbol used in the RENISHAW logo are registered trade marks of Renishaw plc in the United Kingdom and other countries.

apply innovation and names and designations of other Renishaw products and technologies are trade marks of Renishaw plc or its subsidiaries.

All other brand names and product names used in this document are trade names, service marks, trademarks, or registered trademarks of their respective owners.

Warranty

Equipment requiring attention under warranty must be returned to your equipment supplier.

Unless otherwise specifically agreed in writing between you and Renishaw, if you purchased the equipment from a Renishaw company, the warranty provisions contained in Renishaw's CONDITIONS OF SALE apply. You should consult these conditions in order to find out the details of your warranty, but in summary the main exclusions from the warranty are if the equipment has been:

- neglected, mishandled or inappropriately used; or
- modified or altered in any way except with the prior written agreement of Renishaw.

If you purchased the equipment from any other supplier, you should contact them to find out what repairs are covered by their warranty.

Changes to equipment

Renishaw reserves the right to change equipment specifications without notice.

CNC machines

CNC machine tools must always be operated by fully trained personnel in accordance with the manufacturer's instructions.

Care of the RMI-Q

Keep system components clean.

RMP probe family

The RMP family of probes currently consists of the RMP40, RMP40M, RLP40, RMP60, RMP60M and RMP600. The RTS radio tool setter also forms part of Renishaw's family of radio transmission probes. The term RMP used throughout this installation guide refers to both the probes and the tool setter.

Patents

Features of the RMI-Q (and features of similar products) are the subject of one or more of the following patents and/or patent applications:

CN	100466003	JP	2009-507240
CN	101287958	JP	3126797
CN	101482402A	JP	4575781
EP	0652413	KR	1001244
EP	1576560	TW	1333052
EP	1931936	US	2011-00002361-A1
EP	2216761	US	5279042
IN	2004/057552	US	7665219
IN	2007/028964	US	7821420
IN	215787		

EC declaration of conformity



Renishaw PLC hereby declares that the RMI-Q is in compliance with the essential requirements and other relevant provisions of Directive 1999/5/EC. Contact Renishaw at www.renishaw.com/rmi-q for the full EC Declaration of Conformity.

WEEE directive

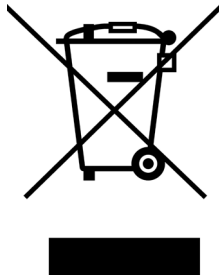

The use of this symbol on Renishaw products and/or accompanying documentation indicates that the product should not be mixed with general household waste upon disposal. It is the responsibility of the end user to dispose of this product at a designated collection point for waste electrical and electronic equipment (WEEE) to enable reuse or recycling. Correct disposal of this product will help to save valuable resources and prevent potential negative effects on the environment. For more information, please contact your local waste disposal service or Renishaw distributor.

FCC information to the user (USA only)

47 CFR Section 15.19

The user is cautioned that any changes or modifications not expressly approved by Renishaw plc, or authorised representative could void the user's authority to operate the equipment.

This device complies with Part 15 of the FCC rules.

Operation is subject to the following two conditions:

1. This device may not cause harmful interference.
2. This device may accept any interference received, including interference that may cause undesired operation.

47 CFR Section 15.21

The user is cautioned that any changes or modifications not expressly approved by Renishaw plc, or authorised representative could void the user's authority to operate the equipment.

47 CFR Section 15.105

This equipment has been tested and found to comply with the limits for a Class A digital device, pursuant to Part 15 of the FCC rules. These limits are designed to provide reasonable protection against harmful interference when the equipment is operated in a commercial environment. This equipment generates, uses, and can radiate radio frequency energy and, if not installed and used in accordance with the instruction manual, may cause harmful interference to radio communications. Operation of this equipment in a residential area is likely to cause harmful interference, in which case you will be required to correct the interference at your own expense.

Radio approval

Radio equipment - Canadian warning statements

English

Under Industry Canada regulations, this radio transmitter may only operate using an antenna of a type and maximum (or lesser) gain approved for the transmitter by Industry Canada.

To reduce potential radio interference to other users, the antenna type and its gain should be so chosen that the equivalent isotropically radiated power (e.i.r.p.) is not more than that necessary for successful communication.

This device complies with Industry Canada licence-exempt RSS standard(s). Operation is subject to the following two conditions: (1) this device may not cause interference, and (2) this device must accept any interference, including interference that may cause undesired operation of the device.

French

Conformément à la réglementation d'Industrie Canada, le présent émetteur radio peut fonctionner avec une antenne d'un type et d'un gain maximal (ou inférieur) approuvé pour l'émetteur par Industrie Canada.

Dans le but de réduire les risques de brouillage radioélectrique à l'intention des autres utilisateurs, il faut choisir le type d'antenne et son gain de sorte que la puissance isotrope rayonnée équivalente (p.i.r.e.) ne dépasse pas l'intensité nécessaire à l'établissement d'une communication satisfaisante.

Le présent appareil est conforme aux CNR d'Industrie Canada applicables aux appareils radio exempts de licence. L'exploitation est autorisée aux deux conditions suivantes : (1) l'appareil ne doit pas produire de brouillage, et (2) l'utilisateur de l'appareil doit accepter tout brouillage radioélectrique subi, même si le brouillage est susceptible d'en compromettre le fonctionnement.

Radio approvals

Europe:	TBA
USA:	TBA
Canada:	TBA
Japan:	TBA
China:	TBA

Safety

Information to the user

In all applications involving the use of machine tools or CMMs, eye protection is recommended.

Information to the machine supplier/installer

It is the machine supplier's responsibility to ensure that the user is made aware of any hazards involved in operation, including those mentioned in Renishaw product literature, and to ensure that adequate guards and safety interlocks are provided.

Under certain circumstances, the probe signal may falsely indicate a probe seated condition. Do not rely on probe signals to halt the movement of the machine.

Information to the equipment installer

All Renishaw equipment is designed to comply with the relevant EU and FCC regulatory requirements. It is the responsibility of the equipment installer to ensure that the following guidelines are adhered to, in order for the product to function in accordance with these regulations:

- any interface **MUST** be installed in a position away from any potential sources of electrical noise, i.e. power transformers, servo drives etc;
- all ground connections should be connected to the machine 'star point' (the 'star point' is a single point return for all equipment ground and screen cables). This is very important and failure to adhere to this can cause a potential difference between grounds;
- all screens must be connected as outlined in the user instructions;
- cables must not be routed alongside high current sources, i.e. motor power supply cables etc, or be near high speed data lines;
- cable lengths should always be kept to a minimum.

Equipment operation

If this equipment is used in a manner not specified by the manufacturer, the protection provided by the equipment may be impaired.

This page left intentionally blank

RMI-Q basics

Introduction

CNC machine tools which are using Renishaw spindle probes with radio signal transmission for workpiece inspection, or tool setters with radio signal transmission, require a Renishaw radio machine interface (such as the RMI-Q) for signal transmission. The RMI-Q, which acts as a combined radio transceiver and machine interface, converts signals from the RMP into voltage-free solid state relay (SSR) and driven outputs for transmission to the CNC machine controller.

The RMI-Q is designed to be mounted within the machine's working envelope.

Application of the RMI-Q enables individual radio turn on and subsequent operation of up to four separate 2nd generation RMPs, permitting numerous combinations of radio inspection probes and/or radio tool setters to be used on the same machine tool.

RTS, and other 2nd generation RMPs, are easily identified by a 'Q' marking. 1st generation RMPs, which do not have the 'Q' marking, may also be used with the RMI-Q. However, in machine tool applications where more than one RMP is required, it is recommended that only 2nd generation RMPs are used. Should there be a requirement to use a 1st generation RMP with the RMI-Q, it is necessary that any additional probes are 'Q' marked 2nd generation RMPs

Optimum communication performance between the RMI-Q and the RMP is achieved when the RMI-Q is aligned towards the RMP in operation. Other alignments are permissible with negligible reduction in communication performance. However, alignment of the RMI-Q away from the RMP should be avoided as this may result in reduced communication performance.

 **CAUTION** RMI-Q operation of up to four separate RMPs is different to 'multiple probe mode' which is a function of the RMP that enables individual application of multiple probes but does not use radio turn on.

Power supply

The RMI-Q can draw its supply from the CNC machine tool's 12 Vdc to 30 Vdc supply and present a peak load of up to 250 mA during turn on (typically 100 mA from 24 V).

Input voltage ripple

The input voltage ripple must not cause the voltage to fall below 12 V or rise above 30 V.

RMI-Q visual diagnostics

A visual indication of system status is provided by LEDs. Status is continuously updated and indication is provided for:

- P1, P2, P3, P4 SYSTEM STATUS;
- LOW BATTERY/START;
- PROBE STATUS;
- SIGNAL CONDITION;
- ERROR;

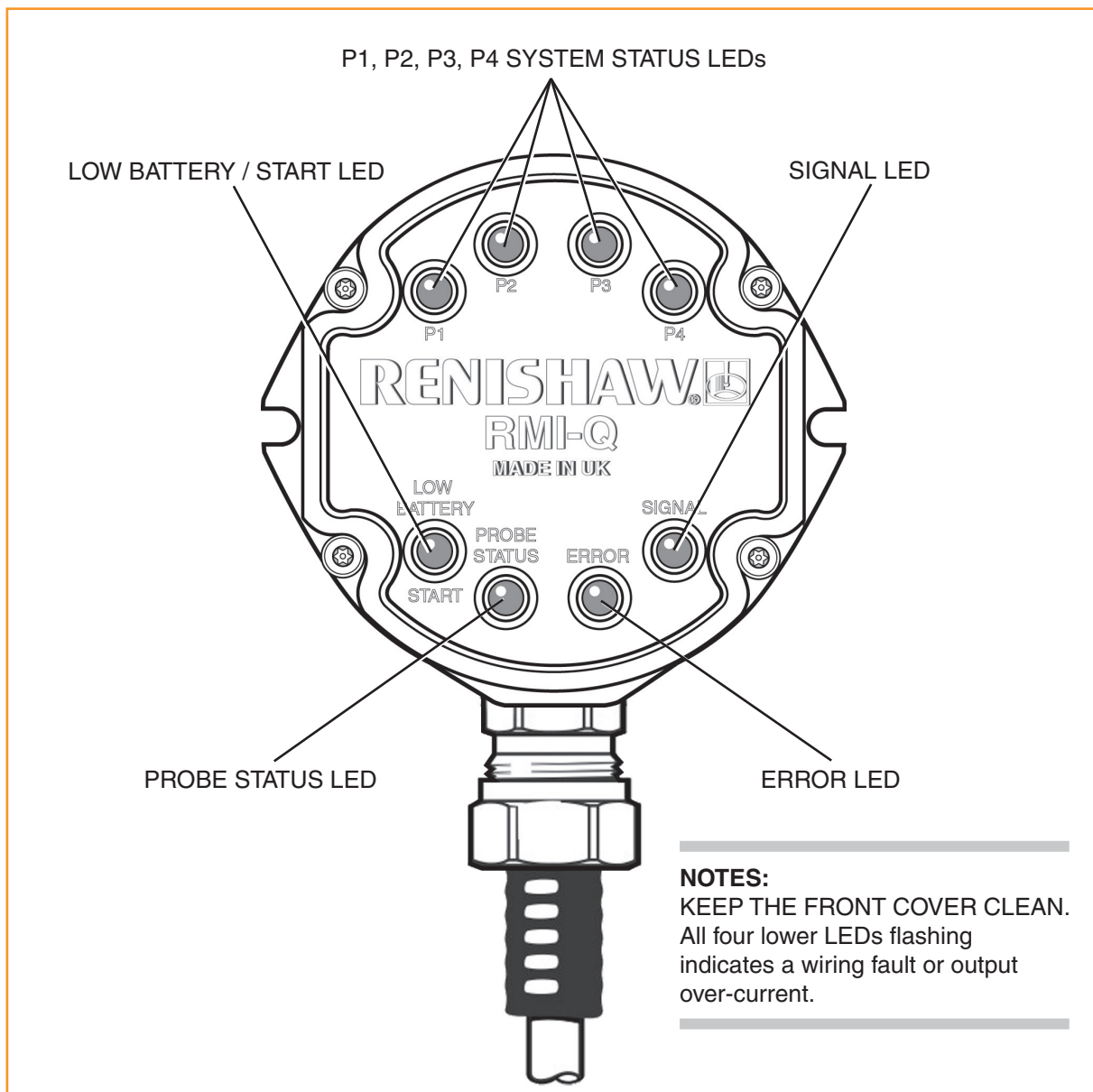

P1, P2, P3, P4 SYSTEM STATUS LEDs

- Off - Probe number empty.
- Yellow - Probe number full, in standby.
- Green - Probe number full, operating.
- Red - Probe number full, 0.5 s compatibility error.
- Yellow/off - Flashing: Selection error.
- Green/yellow - Flashing: Acquisition/clearing pending, full.
- Green/off - Flashing: Acquisition pending, empty.
- Red/yellow - Flashing: Acquisition complete, probe full.
- Red/off - Flashing: Clearing complete, probe empty.

LOW BATTERY / START LED

- Off - Battery is OK and no M code start/stop in progress.
- Red - Battery is low.
- Green - M code start/stop in progress.
- Yellow - Battery low and M code start/stop in progress.
- Red/off - Flashing: RMI-Q has an overcurrent condition.

PROBE STATUS LED

- Red - Probe triggered.
- Green - Probe seated.
- Red/off - Flashing: RMI-Q has an overcurrent condition.

ERROR LED

- Off - No error.
- Red - Error, other outputs may be incorrect.
- Red/off - Flashing: RMI-Q has an overcurrent condition.

SIGNAL LED

- Off - No probes operating.
- Green - Good communications.
- Green - yellow - Good communications.
- Red - Poor communications, radio link may fail.
- Red/off - Flashing: RMI-Q has an overcurrent condition.

NOTES:

The 'PROBE STATUS' LED is always illuminated when power is present at the RMI-Q (as the RMI-Q does not incorporate a separate 'power present' indicator).

All LEDs report the status of the partner RMP. If there is no partner in range, or the partner is off, then the 'PROBE STATUS' and 'ERROR' LEDs will illuminate red. The 'LOW BATTERY/START' and 'SIGNAL' LEDs will be off.

When the RMI-Q is powered on it will enter the acquire partner mode. This is indicated by a flashing green 'SIGNAL' LED (no change in outputs). After ~60 seconds it will switch to its normal mode listening for its partner.

The conditions shown by the 'LOW BATTERY/START', 'PROBE STATUS' and 'ERROR' LEDs are the same as those present on the electrical signal outputs.

RMI-Q inputs

Machine start inputs (P1, P2, P3, P4):

'Machine start' inputs are configurable as a level or pulsed signal.

Level	10 to 30 V (2.4 mA at 24 V) When input is active, probe is switched on.
Pulsed	12 to 30 V (10 mA at 24 V) Probe toggles from being switched on/off. The minimum pulse width is 10 ms.

P1 machine start wires (white +ve and brown -ve).

P2 machine start wires (pink +ve and brown -ve).

P3 machine start wires
(white/red +ve and brown -ve).

P4 machine start wires
(white/blue +ve and brown -ve).

RMI-Q outputs

There are five outputs:

- Probe status 1 (SSR).
- Probe status 2a (5 V isolated driven skip).
- Probe status 2b (driven at power supply voltage).
- Error (SSR).
- Low battery (SSR).

All outputs can be inverted by using switches SW1 and SW2 - see page 2.8 '**Switches SW1 and SW2**'.

Probe status 1, Error, Low battery (SSR):

- 'On' resistance = 50 ohm max.
- Load voltage = 40 V max.
- Load current = 100 mA max.

Probe status 2a (5 V isolated driven skip):

- Load current = 50 mA max.

Output voltages

- Sourcing = 4.2 V min at 10 mA.
= 2.2 V min at 50 mA.
- Sinking = 0.4 V max at 10 mA.
= 1.3 V max at 50 mA.

Probe status 2b (driven at power supply voltage):

- Load current = 50 mA max.

Output voltages

- Sourcing voltage drop = 2.6 V max at 10 mA.
= 3.5 V max at 50 mA.
- Sinking voltage drop = 2.0 V max at 10 mA.
= 2.9 V max at 50 mA.

The 'LOW BATTERY/START', 'PROBE STATUS', 'ERROR' and 'SIGNAL' LEDs will start flashing red when an output overload has occurred. All outputs will be switched off. If this occurs, turn off the power supply and remove the source of the problem. Turning on the power supply will reset the RMI-Q.



CAUTIONS:

Power supply voltage

Do not exceed 30 V between the black wire and the screen wire (green/yellow), or the red wire and screen wire (green/yellow), or the red and black wires (power supply), as this could result in permanent damage to the RMI-Q and/or the customer power supply.

The use of in-line fuses at the machine cabinet end is recommended to provide protection for the RMI and cable.

Screen connection

A good connection must be made to machine ground (star point).

Output stage circuit

Output stage supplies (+ve, -ve) should not be switched on and off to enable/disable them as this can cause the over current protection to switch off the output completely.

Ensure that outputs from the RMI-Q do not exceed specified current ratings.

RMI-Q output waveforms

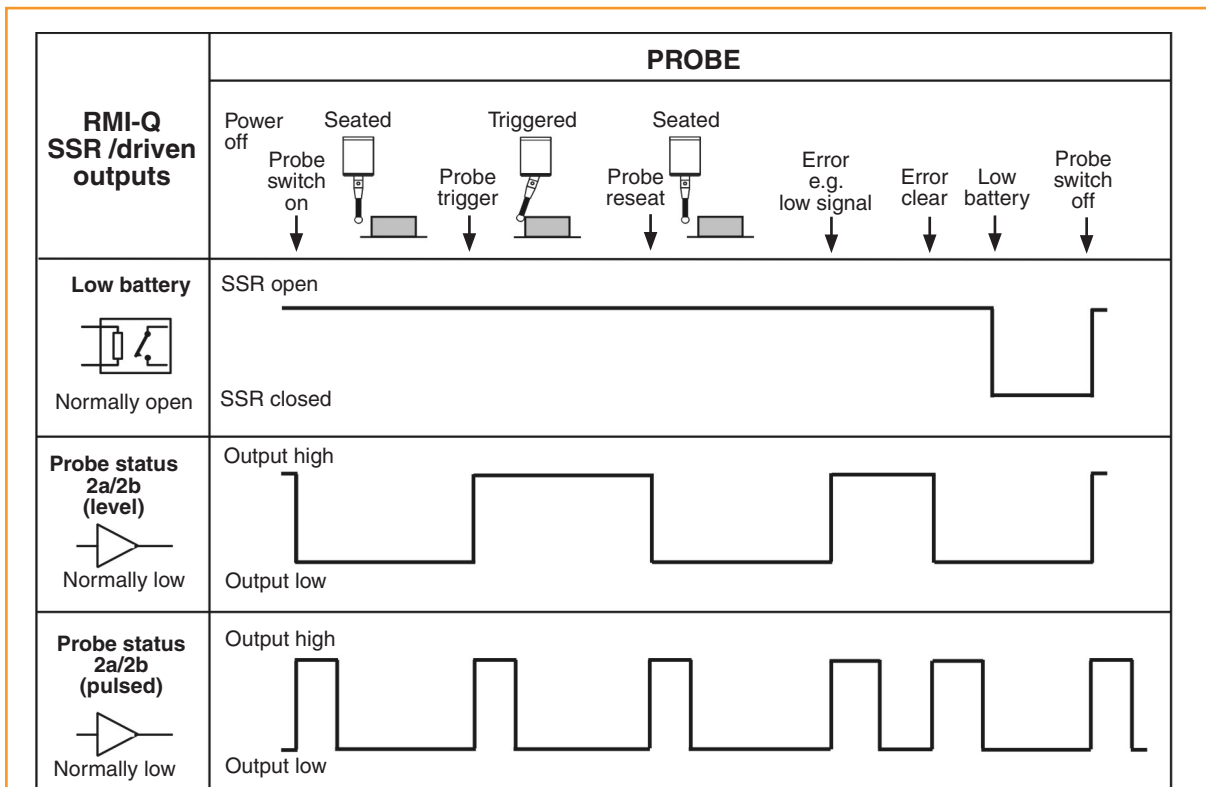
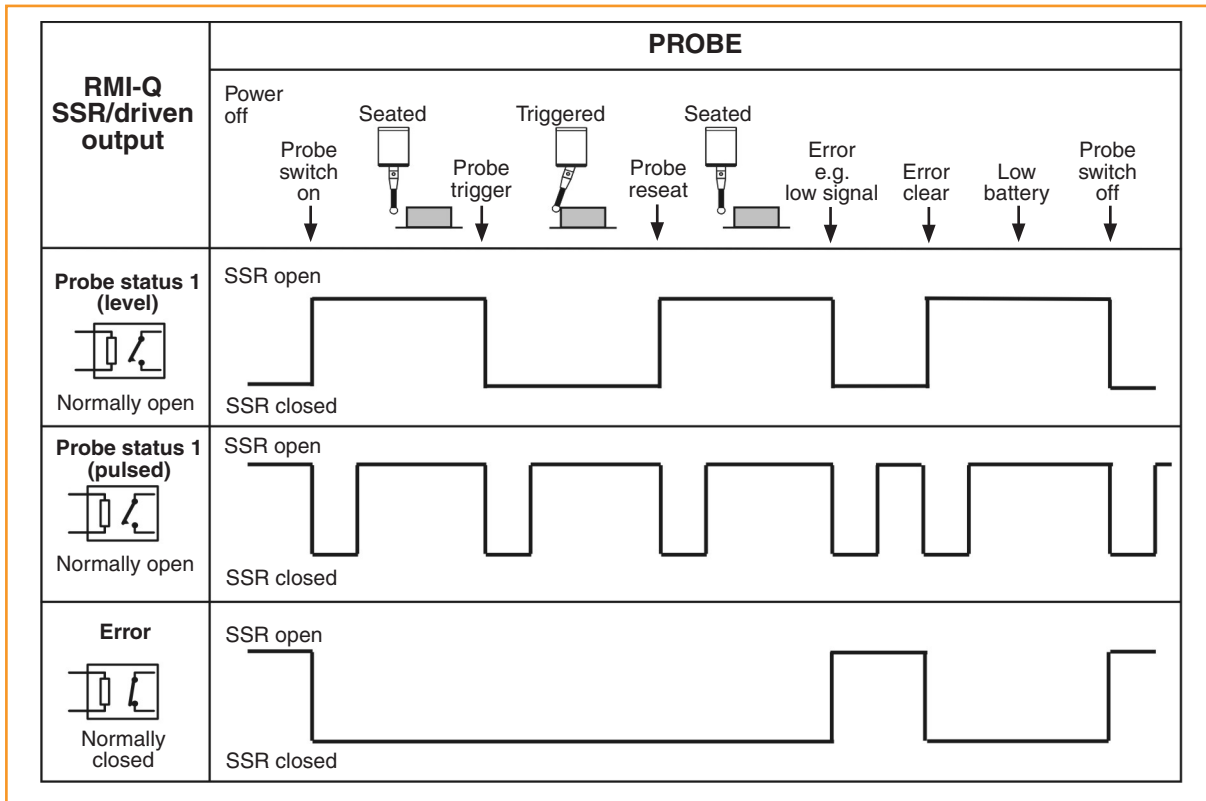

SIGNAL DELAYS

1. **Transmission delay** Probe trigger to output change of state ≈ 10 ms variation ± 10 μ s.
(Standard turn on mode excluding filter delay)
2. **Start delay** Time from initiation of start signal to valid signal transmission = 1 sec max.

NOTE : Pulsed outputs are 40 ms \pm 1 ms duration.

RMI-Q seated start option

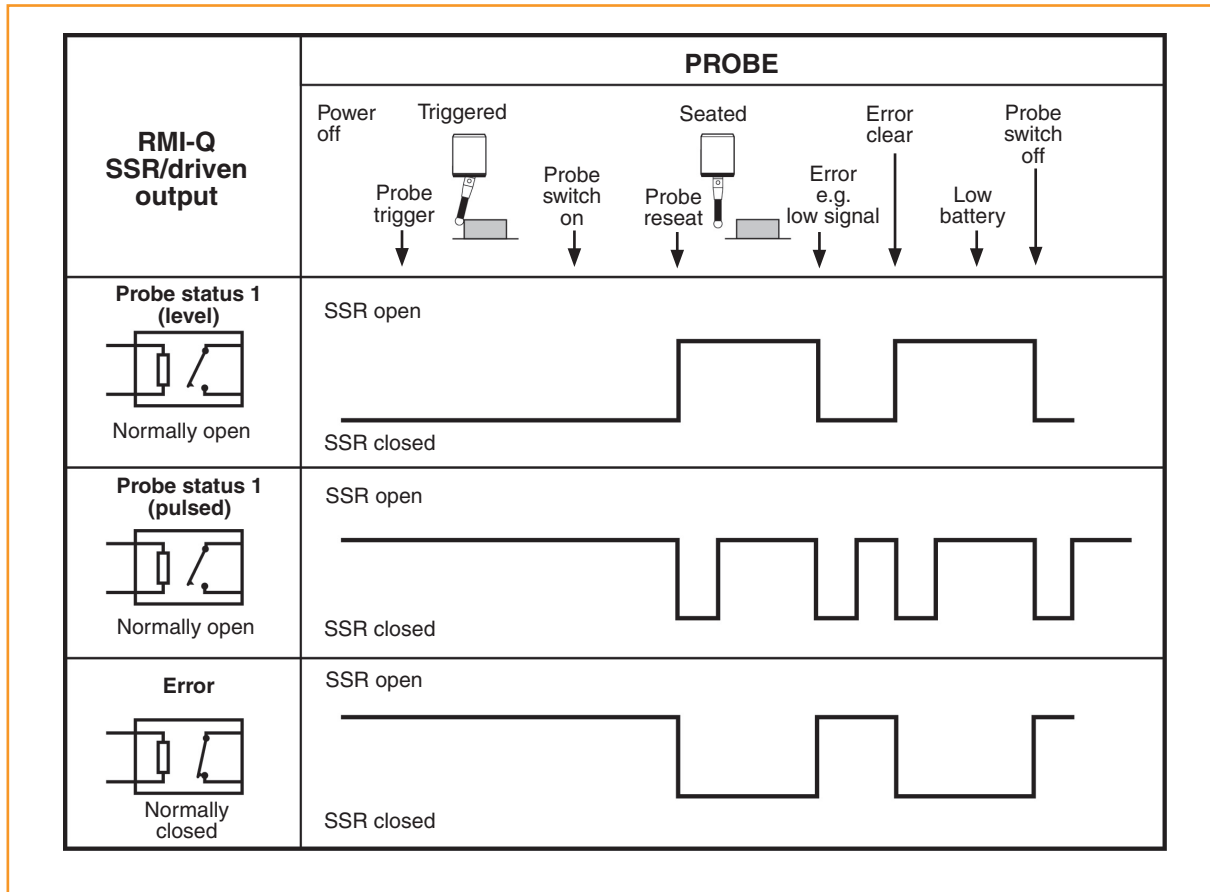

Switches SW1 and SW2

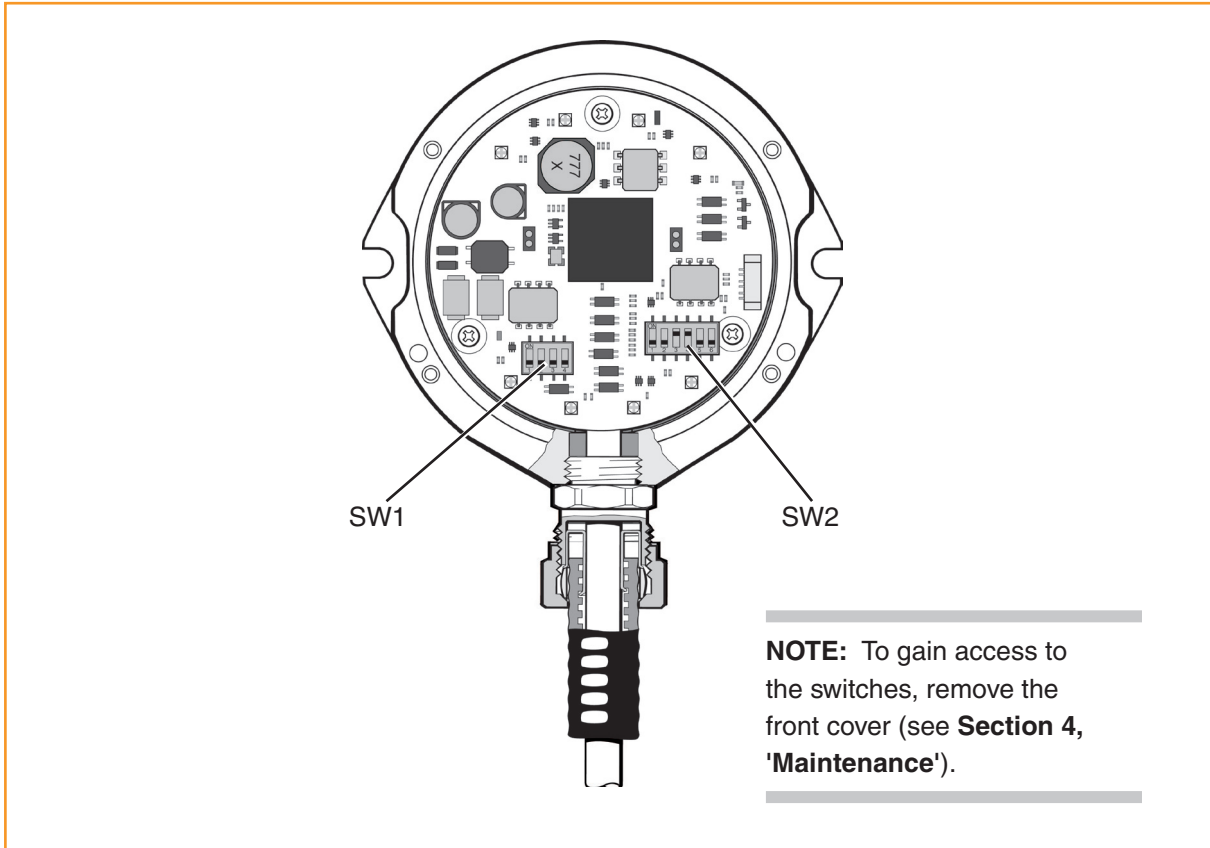

Switch SW1 output configuration

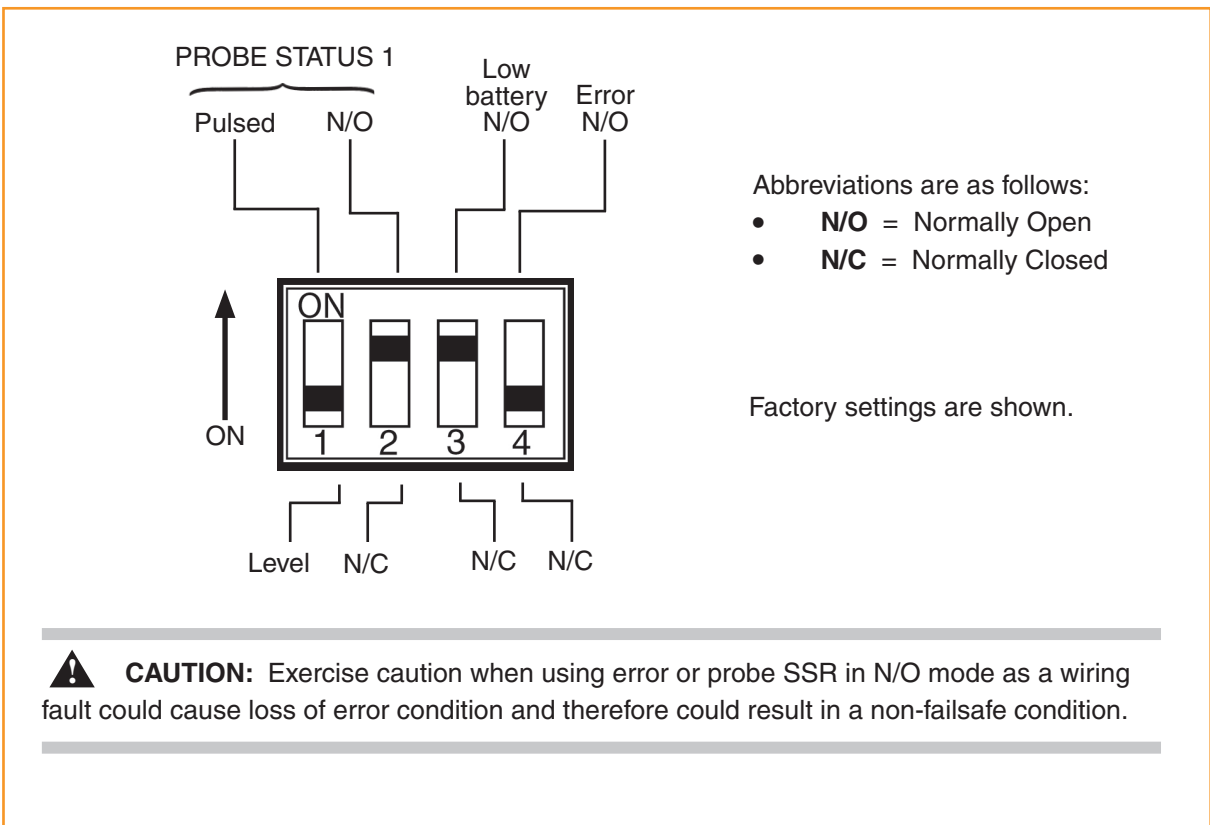

Switch SW2 output configuration

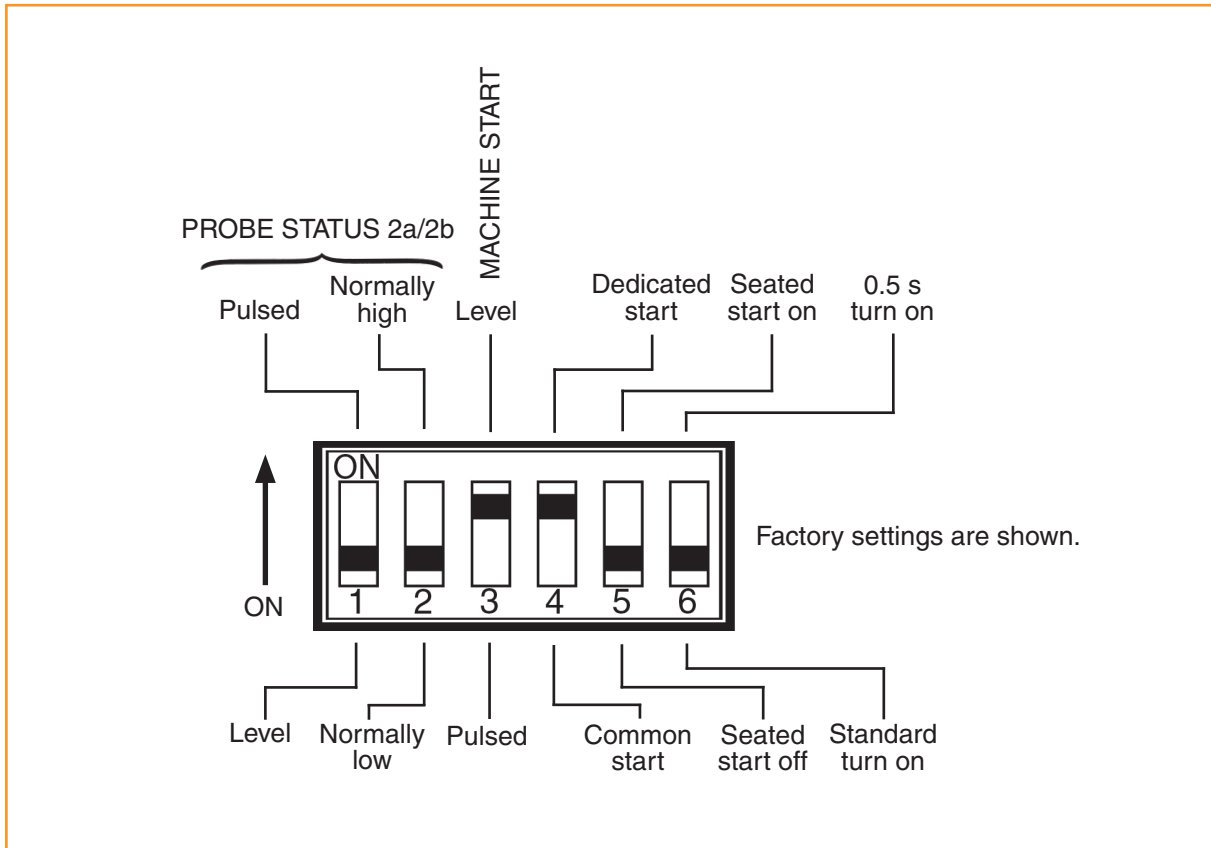

Dedicated start (level mode)

In dedicated start, a machine start input is required per probe that is configured for radio turn on.

Machine start inputs				Probe selected
P1	P2	P3	P4	
				None
*				Probe 1 on
	*			Probe 2 on
		*		Probe 3 on
			*	Probe 4 on

* Machine start input active. Any attempt to turn on more than one probe simultaneously will result in an error condition

NOTES :

Level start mode is not compatible with RMPs configured for radio M code on/time out off.

For RMI compatibility mode, ensure poles 4 and 6 are in the down position and set other poles to the required configuration.

Common start (level mode)

In common start (level mode), machine start inputs P2 and P3 are used to select the probe and machine start input P1 is used to start the selected probe. All inputs are level.

Machine start inputs P1, P2 and P3			Probe selected
Probe start	Probe selection inputs		
P1	P2	P3	
*			Probe 1
*	*		Probe 2
*		*	Probe 3
*	*	*	Probe 4

* Machine start input active.
When P1 is off, all probes are off.
When P1 is active, the selected probe will be on.

NOTES:





Machine start input P4 is not used in common start.

Any change to the probe selection inputs P2 and P3 whilst the probe is operating will result in an error condition.

Level start mode is not compatible with RMPs configured for radio M code on/time out off.

Common start (pulsed mode)

In common start (pulsed mode), machine start inputs P2 and P3 are level inputs used to select the probe. Machine start input P1 is a pulsed input used to start the selected probe.

Machine start inputs P1, P2 and P3			Probe selected
Probe start	Probe selection inputs		
P1	P2	P3	
			Probe 1
	*		Probe 2
		*	Probe 3
	*	*	Probe 4

 Machine start input pulsed, so selected probe will change state.
* Probe selection inputs are level signals.

NOTES:

Machine start input P4 is not used in common start.

Only the probe start signal P1 will be pulsed and will change the probe status between on and off. The probe selection inputs P2 and P3 will be level.

Seated start on

When seated start on is selected, the RMI-Q will not drop the error line until the RMP has become seated. This provides compatibility with controllers that regard the RMP to be in error if it is started in a triggered condition.

0.5 second turn on

0.5 second turn on provides compatibility with controllers that have quicker response times, to give a reduced probing cycle time. Standard turn on time is 1 second. These turn on times apply to radio M code on only.

Remote external audible output

Any output (set to pulsed) can be utilised to operate an external remote audible indicator.

The audible indicator must comply with the output transistor specification.

- i.e. up to 50 mA.
- up to 30 V.

Wiring configurations are shown below.

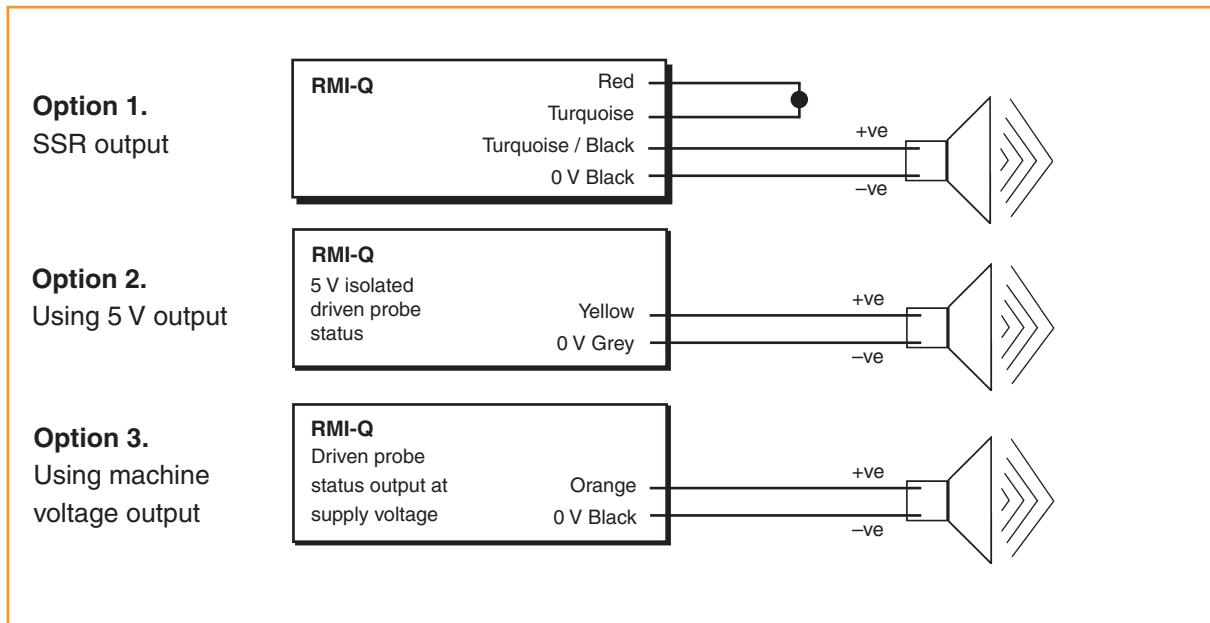

RMI-Q dimensions

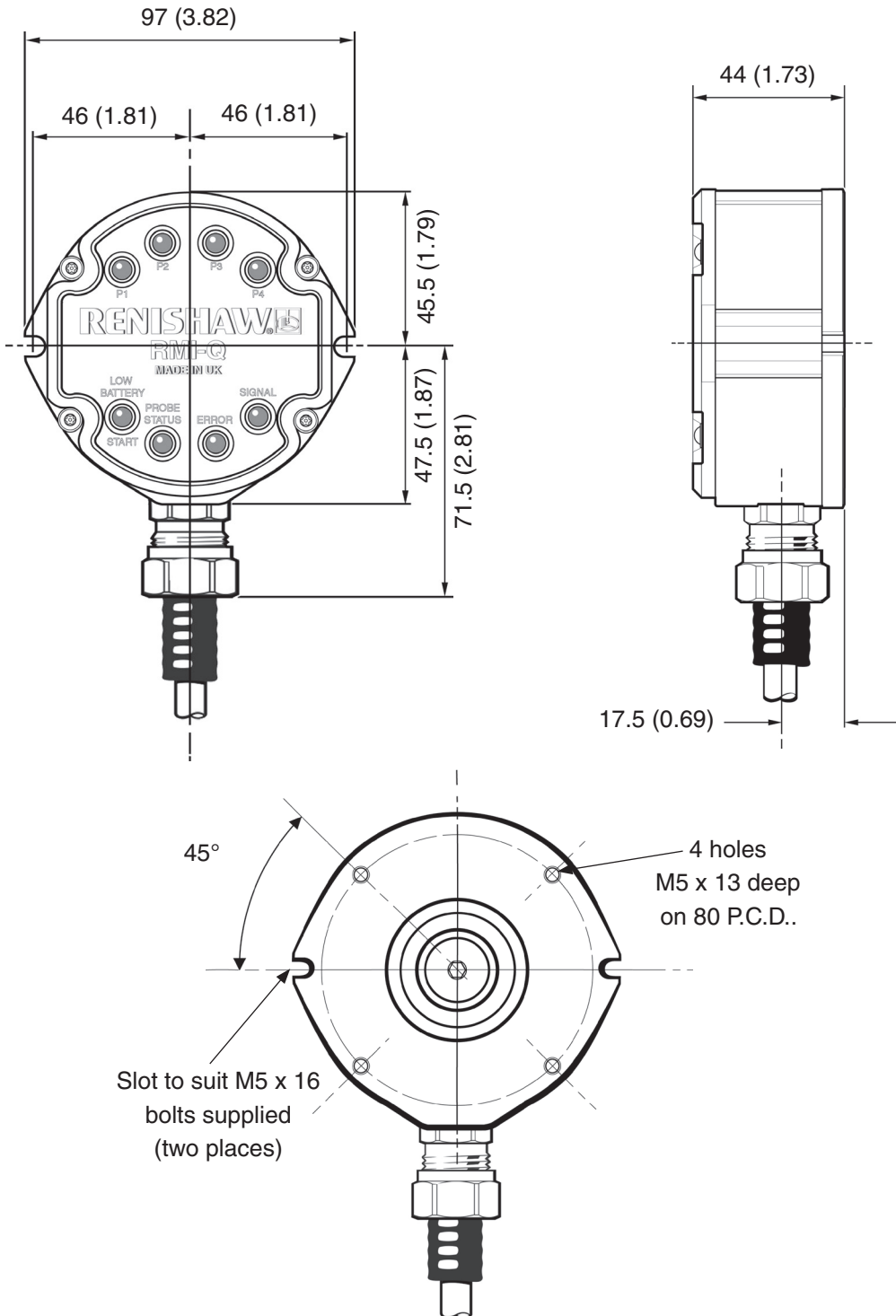

NOTE: When using rear exit cable, provide a Ø25 mm (Ø1.0 in) hole in the mounting for the cable to exit.

Dimensions given in mm (in)

RMI-Q specification

Principal application	Any machining centre, 5-axis machine, twin spindle machine and vertical turret lathe.	
Dimensions	Height	119 mm (4.68 in)
	Width	97 mm (3.82 in)
	Depth	44 mm (1.73 in)
Weight	In box	2,065 g (72.84 oz)
	RMI-Q including 15 m (49.2 ft) of cable	1,625 g (57.32 oz)
Transmission type	Frequency hopping spread spectrum (FHSS) radio. 2.400 - 2.4835 GHz 2400 - 2483.5 MHz	
Transmission range	Up to 15 m (49.2 ft)	
Power supply	12 Vdc to 30 Vdc	
Cable	8 m (26.2 ft) and 15 m (49.2 ft) standard lengths Optional 30 m (98.42 ft) and 50 m (164.04 ft) cable assemblies are also available. 16 core screened cable, each core 18 x 0.1 mm	
Mounting	Mounting bracket allowing directional setting	
Compatible probes	Component setting/inspection: RMP40, RMP40M, RMP60, RMP60M and RMP600 Lathe inspection: RLP40 Tool setting: RTS	
Environment	IP rating	IPX8 (EN/IEC605290)
	Storage temperature	-25 °C to +70 °C (-13 °F to +158 °F)
	Operating temperature	+5 °C to +55 °C (+41 °F to +131 °F)

This page left intentionally blank

System installation

Mounting bracket (optional)

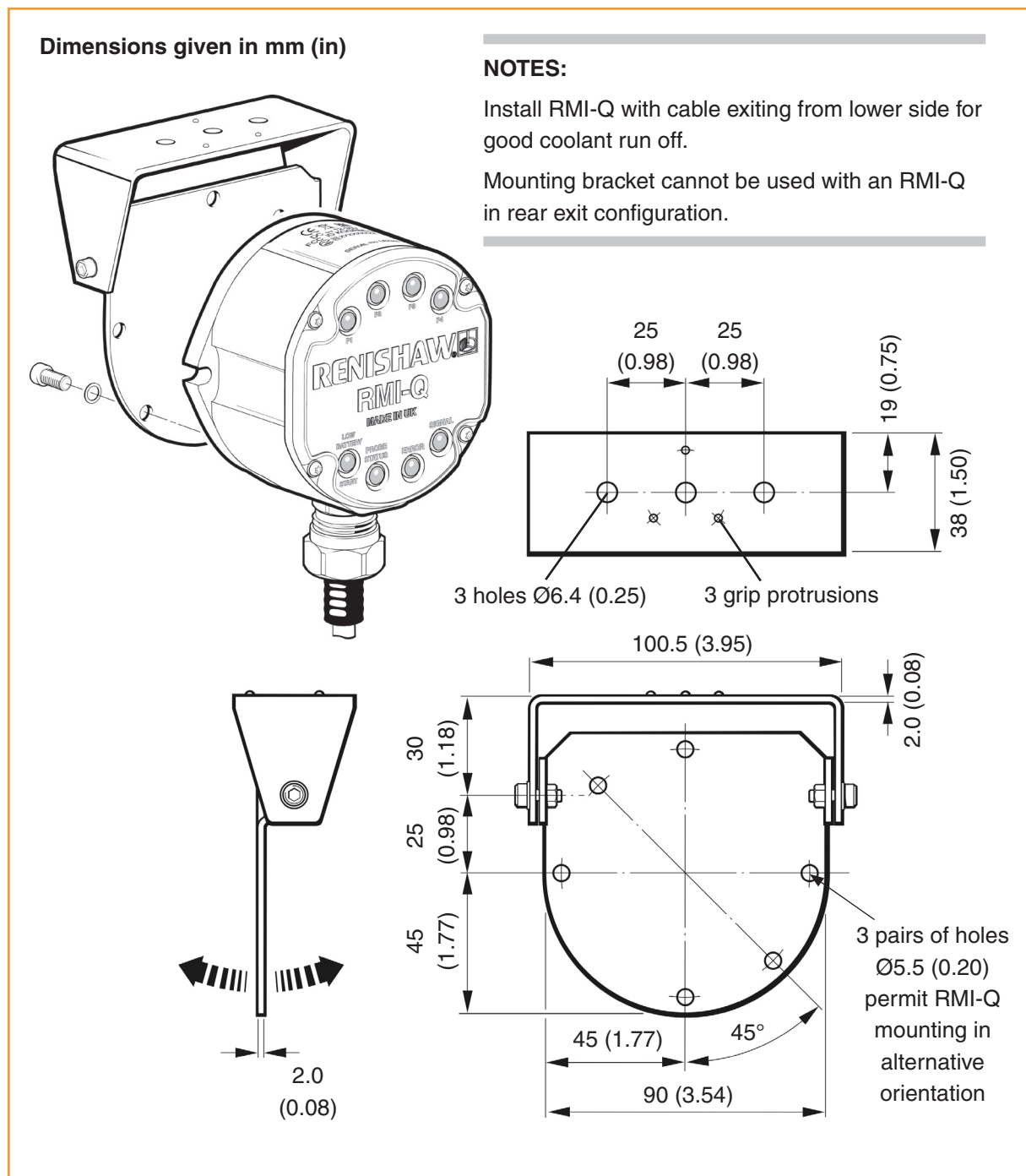

Wiring diagram (with output groupings shown)

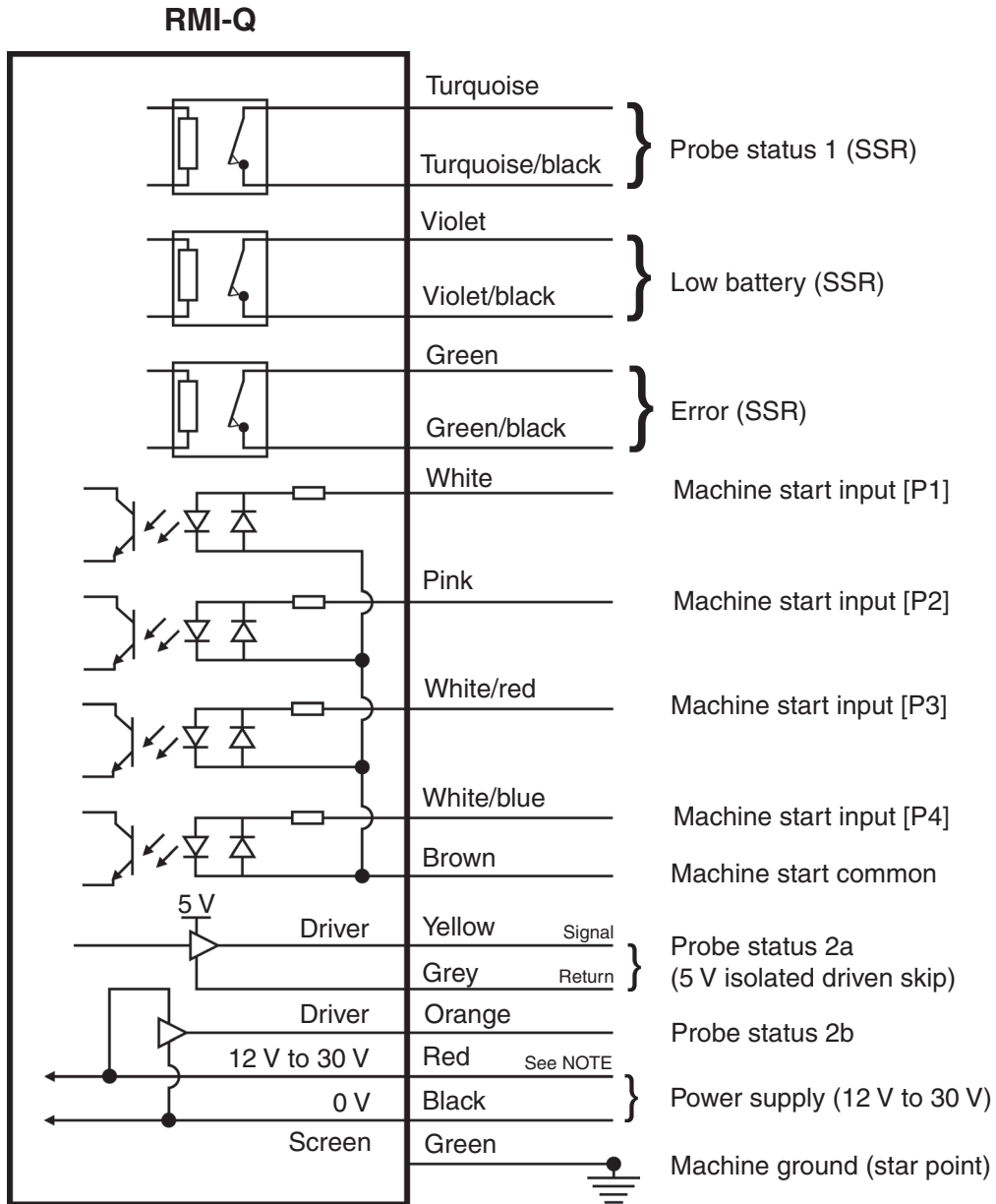

NOTE: A switch can be added on installation to aid with powering up the RMI-Q when partnering.

CAUTION: The power supply 0 V should be terminated at the machine ground (star point). A negative supply can be used when wired appropriately.

RMP - RMI-Q partnership

The RMP and RMI-Q must be placed into acquisition mode.

On the RMP, acquisition mode achieved using Trigger Logic™.

On the RMI-Q, acquisition mode is achieved either by manually power cycling the RMI-Q, or via application of ReniKey which is a Renishaw machine macro cycle.

Trigger Logic™ is a method that allows the user to view and select all available mode settings in order to customise a probe to suit a specific application. Trigger Logic™ is activated by battery insertion and uses a sequence of stylus deflection (triggering) to systematically lead the user through the available choices to allow selection of the required mode options.

Current probe settings can be reviewed by simply removing the batteries for a minimum of 5 seconds, and then replacing them to activate the Trigger Logic™ review sequence.

To partner the RMP with the RMI-Q

Partnering is required during initial system set-up. Further partnering will be required if either the RMP or RMI-Q are changed.

Any RMP that is partnered with the RMI-Q, but then used with another system, will need to be cleared first from the RMI-Q before being partnered with the new system. The RMP will also need to be partnered again should it be brought back to the RMI-Q.

Partnering will not be lost by reconfiguration of probe settings or when changing batteries.

NOTE: Partnering will be lost when multiple probe mode is selected. Multiple probe mode is a function of the RMP. See the relevant RMP installation guide (see **Section 6, 'Parts list'**).

Partnering can take place anywhere within the operating envelope.

1. Use Trigger Logic™ to access RMP configuration mode.
2. Configure switch-on method (if applicable).
3. Configure switch-off method (if applicable).
4. Configure enhanced trigger filter and auto reset function (if applicable).
5. Enter acquisition mode menu.
6. Power on the RMI-Q or apply one of the ReniKey commands. Please refer to the ReniKey programming manual.
7. Watch the RMI-Q P1 system status LED; after a couple of seconds the LED will repeatedly flash on and off green. This is the start of a 60 second interval in which the RMI-Q is in acquisition mode.
8. Deflect the stylus < 4 seconds to initiate the acquisition process.
9. After successful acquisition, the RMI-Q P1 system status LED will change to repeatedly flashing red and yellow (for 5 seconds) indicating that acquisition is complete and Probe 1 is full.
10. Leave RMP for 20 seconds to go into standby.
11. System is ready to use.

NOTES:

To check that turn on and off settings have not been accidentally changed, insert batteries to review current probe settings.

When holding the RMP do NOT wrap a hand, or anything else, around the glass window.

The system will not function correctly if more than one partnered RMI-Q is within the transmission range of the RMP.

To partner up to four RMPs with the RMI-Q without ReniKey

The RMI-Q has four machine start inputs (P1 - P4) that enable partnering of four radio probes (see wiring diagram on page 3.2).

The partnering procedure is dependant on the start method that has been selected. See page 2.9 for start methods.

Partnering with dedicated start (Level mode)

If the RMI-Q is powered with all start inputs held low, the RMI-Q will complete its start up procedure and partner the RMP as Probe 1.

When the RMI-Q is powered with a single machine start input held high, the RMI-Q will complete its start up procedure and partner the RMP to the probe number represented by the selected machine start input.

Level mode				
Probe to be partnered	Machine start input			
	P1	P2	P3	P4
Probe 1				
Probe 2		*		
Probe 3			*	
Probe 4				*

The system status LED for the selected probe number will repeatedly flash on and off green whilst in acquisition mode.

Partnering with common start

When the RMI-Q is powered, specific machine start inputs need to be held high when partnering the RMP to a specific probe number.

Pulsed mode			
Probe to be partnered	Machine start input		
	P1	P2	P3
Probe 1			
Probe 2		*	
Probe 3			*
Probe 4		*	*

Level mode			
Probe to be partnered	Machine start input		
	P1	P2	P3
Probe 1			
Probe 2	*	*	
Probe 3	*		*
Probe 4	*	*	*

NOTES:

Activation of machine start input (P4) is not required when common start is selected.

To aid partnering, an on/off switch can be fitted between the machine power supply and the RMI-Q (red wire). This enables the RMI-Q to be momentarily powered off and then back on, for each of the probes being partnered, without having to power off the machine.

Partnering RMPs using ReniKey (Recommended)

ReniKey is a Renishaw machine macro cycle. It enables up to four RMPs to be partnered with the RMI-Q without the need to power the RMI-Q off and then back on for each of the probes being partnered. Please refer to the ReniKey programming manual for instructions on how to use ReniKey with your machine's controller. Alternatively, refer to www.renishaw.com.

Removing the RMP from the RMI-Q

An RMP must be cleared from the RMI-Q when it is removed from the system. The probe number is cleared from the RMI-Q by repeating the partnering procedure whilst the corresponding machine start input is held high. The RMI-Q will then display that the probe number was cleared. Alternatively, the RMP can be cleared via application of the ReniKey machine macro cycle. Please refer to the ReniKey programming manual on how to use ReniKey with your machine's controller. Alternatively, refer to www.renishaw.com. ReniKey can also be used to clear all probe numbers at the same time. If the cleared RMP is to be used again with the RMI-Q, it must be re-partnered.

Changing RMP position

If, during partnering with all procedures, the RMI-Q acquires an RMP that is already stored under a different probe number, the RMP will be cleared from its current location and stored under the new probe number selected for acquisition.

RMI-Q cable

Cable termination

A ferrule should be crimped onto each cable wire for a more positive connection at the terminal box.

Standard cable variants

The RMI-Q standard cables are 8 m (24.6 ft) and 15 m (49.2 ft) long.

Longer cables are available, please see **Section 6, 'Parts list'**.

Cable specification

Ø7.6 mm (0.3 in), 16 core screened cable, each core 18 x 0.1 mm.

NOTE:

Maximum cable length:
 30 m (98 ft) at 12 V
 50 m (164 ft) at 24 V

Cable sealing

Coolant and dirt are prevented from entering the RMI-Q by the cable sealing gland. The RMI-Q cable can be protected against physical damage by fitting flexible conduit if required.

Recommended flexible conduit is Anamet™ Sealtite HFX (5/16 in) polyurethane.

A conduit kit is available - see **Section 6, 'Parts list'**.

⚠ CAUTIONS:

Failure to adequately protect the cable can result in system failure due to either cable damage or coolant ingress through cores into the RMI-Q.

Failure due to inadequate cable protection will invalidate the warranty.

When tightening or loosening nut **B** on the conduit, ensure that torque is only applied between **A** and **B**.

Fitting flexible conduit

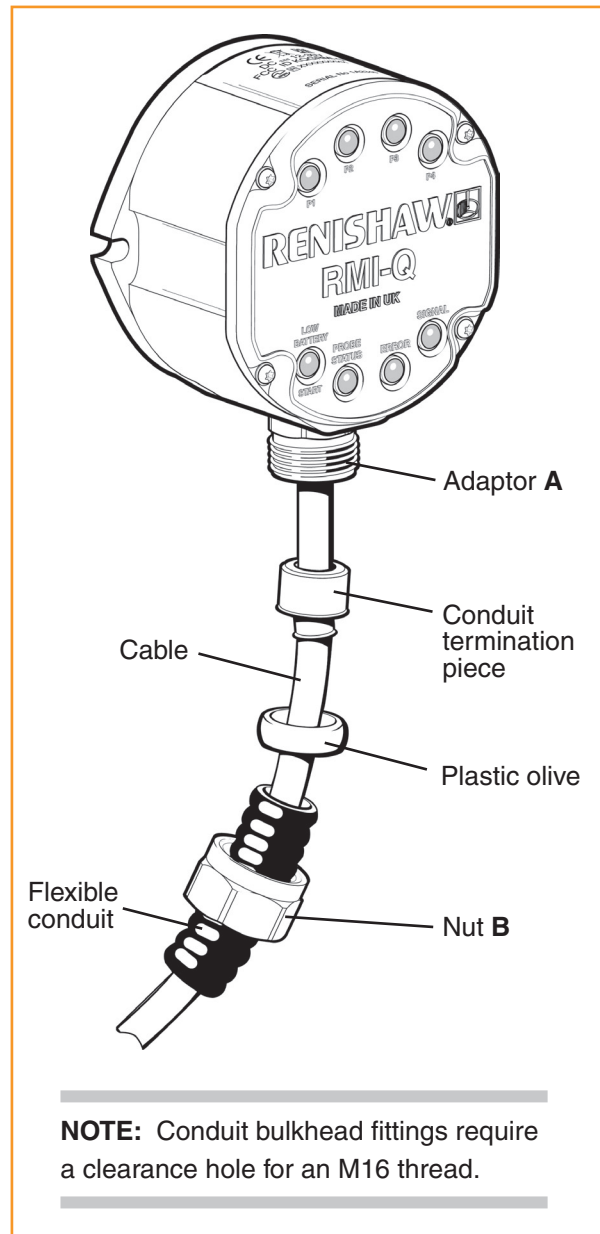

NOTE: Conduit bulkhead fittings require a clearance hole for an M16 thread.

1. Slide nut **B** and plastic olive onto the conduit.
2. Screw conduit termination piece into end of the conduit.
3. Fit conduit to adaptor **A** and tighten nut **B**.

Screw torque values

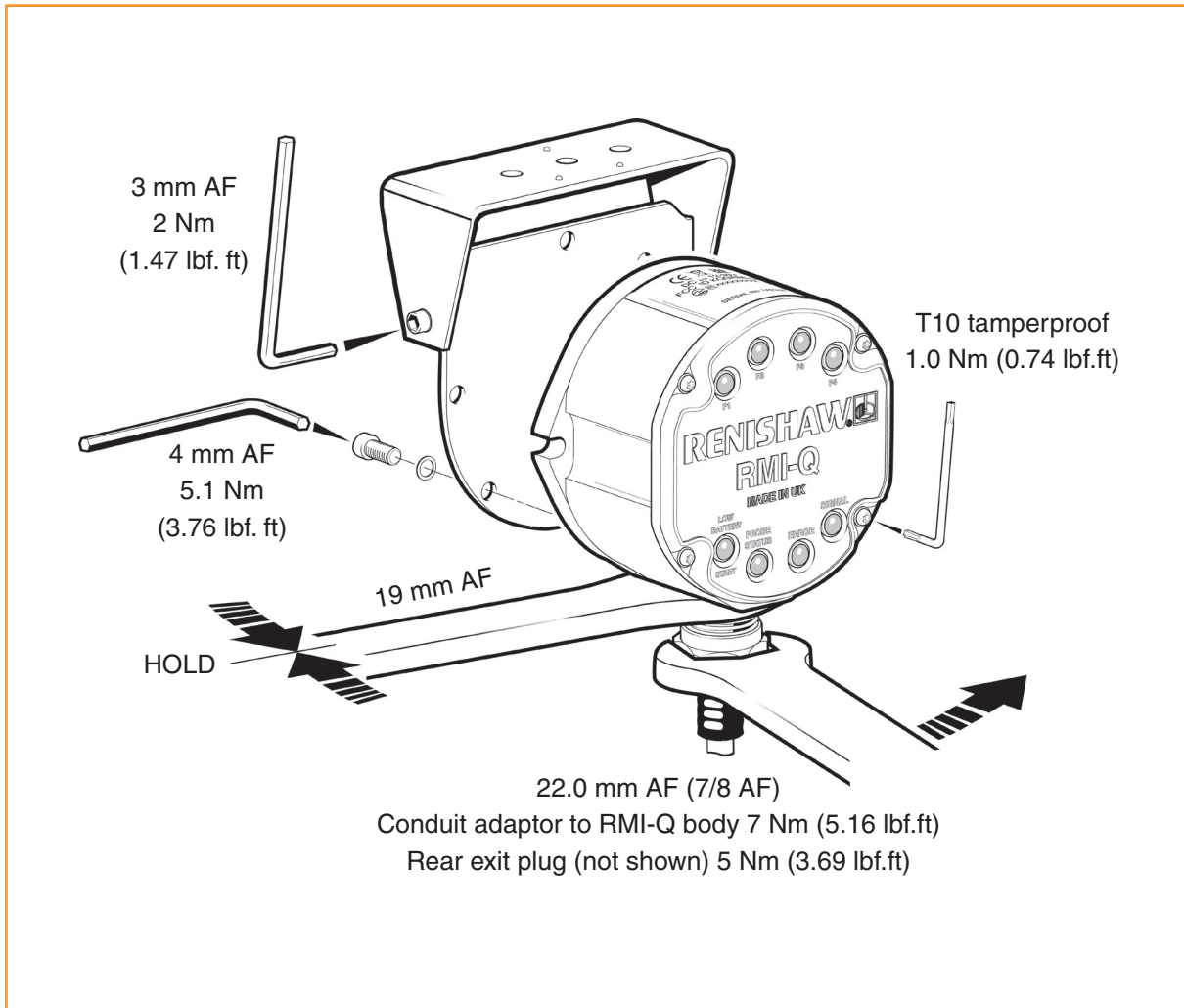

This page left intentionally blank

Maintenance

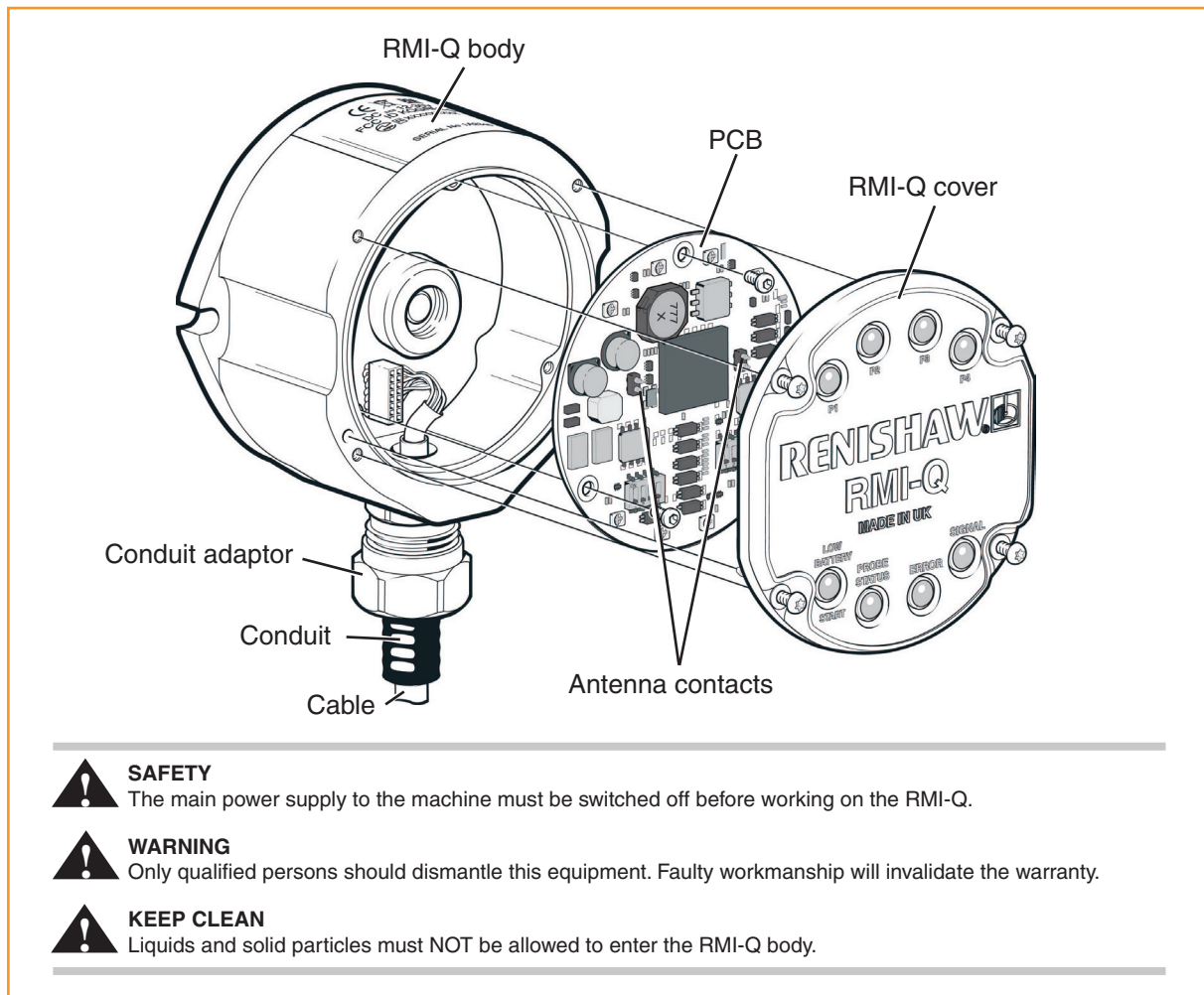

RMI-Q cover

It is not necessary to remove the RMI-Q from the machine when adjusting the switches or installing replacement parts. For torque settings see page 3-5 '**Screw torque values**'.

The front cover may be removed and replaced, as detailed in this section, if there is a need to change configuration.

Removing the RMI-Q cover

1. Clean the RMI-Q thoroughly before servicing to ensure no debris or coolant enters the unit.
2. Using the T10 tamper proof key (provided), unscrew (but do not remove) each captive screw and washer evenly from the cover.
3. When removing the cover, do not twist or rotate by hand.

Replacing the RMI-Q cover

1. Remove the O-ring from the cover. Ensure that the O-ring, the O-ring groove and the cover sealing face are clean. Lubricate the O-ring with silicone grease and refit to cover.
2. Ensure that the O-ring seating on the RMI-Q body is clean, and that there are no scratch marks which could prevent complete sealing.
3. Ensure that the antenna contacts are clean.
4. Place cover, complete with O-ring, onto the RMI-Q body.

NOTE : The O-ring should be lubricated with silicone grease to prevent damage. Do not allow grease to contaminate the antenna contacts.

IMPORTANT: Do not overtighten the cover as distortion could occur.

5. Tighten each captive screw and washer a few turns at a time, to pull the cover down evenly. Screw torque is 1.0 Nm (0.74 lbf.ft.).

Side exit to rear exit cable conversion

1. Remove RMI-Q cover (see page 4.1 '**Removing the RMI-Q cover**').
2. Remove the three crosshead screws retaining the PCB. Carefully remove the PCB and disconnect the cable connection to the PCB.
3. Unscrew the conduit gland from the RMI-Q body.
4. Unscrew the rear exit plug and rubber grommet from the RMI-Q body.
5. Carefully remove the cable assembly and refit through rear exit hole. Tighten the conduit gland. For torque settings see page 3.5 '**Screw torque values**'.
6. Fit the rubber grommet and rear exit plug to the side exit hole and tighten.
7. Connect the PCB to the cable connector. Insert the PCB and retain with the three cross head screws. For torque settings see page 3.7 '**Screw torque values**'.
8. Fit the RMI-Q cover (see page 4.2 '**Replacing the RMI-Q cover**').

 **CAUTION** Conversion from side exit cable to rear exit cable must only be undertaken by qualified personnel. Failure to do so will invalidate the warranty.

Fault finding

Symptom	Cause	Action
No LEDs lit on RMI-Q.	Overvoltage, undervoltage or no power.	Check voltage supply.
	Damaged cable	Check wiring
RMI-Q status LEDs do not correspond to RMP status LEDs.	Radio link failure - RMP out of RMI-Q range.	Check position of RMI-Q, refer to the operating envelope in the relevant RMP installation guide (see Section 6, 'Parts list').
	RMP has been enclosed / shielded by metal.	Review installation.
	RMP and RMI-Q are not partnered.	Partner RMP and RMI-Q.
RMI-Q error LED illuminated (refer to page 2.3).	RMP and RMI-Q are not partnered.	Partner RMP and RMI-Q.
	Dead RMP batteries.	Change RMP batteries.
	Probe not switched on.	Check configuration and alter as required.
	Probe out of range.	Check position of RMI-Q, refer to the operating envelope in the relevant RMP installation guide (see Section 6, 'Parts list').
	Probe selection error.	Verify that one RMP is working and is correctly selected.
	RMP is not compatible with 0.5 second turn on.	Change turn on time to 1 second.
All RMI-Q LEDs flashing.	Wiring fault.	Check wiring.
	Output overcurrent.	Check wiring, turn power to RMI-Q off and on again to reset.

Symptom	Cause	Action
RMI-Q low battery LED lit.	Low RMP batteries.	Change RMP batteries soon.
Reduced range.	Local radio interference.	Identify and remove.
	RMP has been enclosed / shielded by metal.	Review installation.
RMI-Q System Status LED is continually lit red.	RMP is not compatible for 0.5 second turn on.	Change RMI-Q configuration to standard turn on.
		Use an RMP with a 'Q' marking.
Probe will not turn off.	Time out off used with level start option.	Review system setup.

Parts list

Type	Part number	Description
RMI-Q kit	A-5687-0049	RMI-Q with 8 m (26.2 ft) cable, tool kit, quick-start guide and radio approval label.
RMI-Q kit	A-5687-0050	RMI-Q with 15 m (49.2 ft) cable, tool kit, quick-start guide and radio approval label.
Mounting bracket	A-2033-0830	Mounting bracket.
Conduit kit	A-4113-0306	Conduit kit with 1 m (3.28 ft) of polyurethane conduit and bulkhead connector (M16 thread).
Cover assembly	A-5687-0305	Cover/antenna assembly: including cover screws, torx key and O-ring.
Cable assembly	A-5687-0306	Cable assembly 8 m (26.2 ft) long.
Cable assembly	A-5687-0302	Cable assembly 15 m (49.2 ft) long.
Cable assembly	A-5687-0303	Cable assembly 30 m (98.4 ft) long.
Cable assembly	A-5687-0304	Cable assembly 50 m (164 ft) long.
Tool kit	A-4113-0300	Comprising: 1 x T10 tamperproof key, 1 x 4 mm hex key, 14 x ferrules, 4 x M5 screw, 2 x M5 nut, 4 x M5 washer, 1 x O-ring (Ø34.5 x 3 mm).
RMI-Q support software	A-5687-????	CD comprising: ReniKey machine macro cycles with programming manual and macro software for multiple RTS.
Publications. These can be downloaded from our web site at www.renishaw.com		
RMI-Q	A-5687-8500	Quick-start guide: for rapid set-up of the RMI-Q radio machine interface, includes CD with installation guides.
RMP60	A-4113-8501	Quick-start guide: for rapid set-up of the RMP60 probe, includes CD with installation guides.
RMP600	A-5312-8500	Quick-start guide: for rapid set-up of the RMP600 probe, includes CD with installation guides.
RMP40	A-5480-8500	Quick-start guide: for rapid set-up of the RMP40 probe, includes CD with installation guides.
RLP40	A-5627-8500	Quick-start guide: for rapid set-up of the RLP40 probe, includes CD with installation guides.
RTS	A-5646-8500	Quick-start guide: for rapid set-up of the RTS probe, includes CD with installation guides.
Styli	H-1000-3200	Technical specification: Styli and accessories.
Software features	H-2000-2289	Data sheet: Probe software for machine tools – illustrated features.
Software list	H-2000-2298	Data sheet: Probe software for machine tools – list of programs.

NOTE: The serial number of each RMI-Q is found on the top of the housing.

Renishaw plc
New Mills, Wotton-under-Edge,
Gloucestershire, GL12 8JR
United Kingdom

T +44 (0)1453 524524
F +44 (0)1453 524901
E uk@renishaw.com
www.renishaw.com

RENISHAW 
apply innovation™

**For worldwide contact details,
please visit our main website at
www.renishaw.com/contact**



H - 5687 - 8504 - 01