



Operating Manual

OfficeCell™ Distributed Antenna System

Table of Contents

<u>1</u>	<u>LINK DESCRIPTION</u>	1-1
1.1	<u>CAUTIONS AND WARNINGS</u>	1-1
1.2	<u>GENERAL DESCRIPTION</u>	1-1
1.2.1	<u>Basic Principles</u>	1-2
1.2.2	<u>Functional Description</u>	1-3
1.3	<u>SPECIFICATIONS</u>	1-7
<u>2</u>	<u>INSTALLATION</u>	2-1
2.1	<u>GENERAL PROCEDURE</u>	2-1
2.2	<u>INSTALL FIBEROPTIC CABLES</u>	2-4
2.2.1	<u>Minimizing Optical Reflections</u>	2-4
2.2.2	<u>Cleaning Optical Connectors</u>	2-5
2.3	<u>SYSTEM ALARMS</u>	2-6
2.4	<u>HUB SHELF AND REMOTE POWER SUPPLY BATTERY CHARGE MONITORING AND BATTERY REPLACEMENT</u>	2-6
2.4.1	<u>Replacing the Hub Shelf Battery</u>	2-6
2.4.2	<u>Replacing the Remote Power Supply Battery</u>	2-7
2.5	<u>INSTALLATION CHECKLIST</u>	2-7
2.5.1	<u>Inspect Received Items</u>	2-7
2.5.2	<u>Recommended Tools</u>	2-8
2.6	<u>INSTALLING THE HUB SHELF</u>	2-8
2.7	<u>INSTALLING THE REMOTE TRANSCEIVERS</u>	2-9
<u>3</u>	<u>MONITORING AND TROUBLESHOOTING</u>	3-1
3.1	<u>FIELD SUPPORT NUMBERS</u>	3-1
3.2	<u>TROUBLESHOOTING TIPS</u>	3-2

1 Link Description

1.1 Cautions and Warnings

Throughout this manual, these terms appear which highlight the care that should be exercised to ensure personal safety and proper operation of the equipment.



WARNING: *Warning statements identify conditions or practices that could result in injury or loss of life.*



CAUTION: *Caution statements identify conditions or practices that could result in damage to this product or other property.*

NOTE: this equipment has been tested and found to comply with the limits for a Class B digital device, pursuant to Part 15 of the FCC rules. These limits are designed to provide reasonable protection against harmful interference in a residential installation. This equipment generates, uses and can radiate radio frequency energy and if not installed and used in accordance with the instructions, may cause harmful interference to radio communications. However, there is no guarantee that interference will not occur in a particular installation. If this equipment does cause harmful interference to radio or television reception, which can be determined by turning the equipment off and on, the user is encouraged to try to correct the interference by one or more of the following measures:

- Reorient or relocate the receiving antenna
- Increase the separation between the equipment and receiver
- Connect the equipment into an outlet on a circuit different from that to which the receiver is connected
- Consult the dealer or an experienced radio/TV technician for help.



CAUTION: *any modifications to this device not expressly authorized by Repeater Technologies, Inc. could void the user's authority to operate this device.*

1.2 General Description

The OFFICECELL Fiberoptic Distributed Antenna System provides extended coverage of cellular and PCS networks throughout buildings and campus environments. The Hub Shelf is the HUB SHELF which is a 3U (5.25 inch) high, 19 inch wide rack-mounted chassis. The HUB SHELF holds up to 8 HUB TRANSCEIVER Plug-Ins. The Hub Shelf is located in a communications equipment room in the building and is connected to the cellular/PCS base station or repeater via hardline connection. The Hub Shelf may also be connected to the radios of a wireless PBX. Each Hub Shelf is configured with up to eight HUB TRANSCEIVER plug-in cards. Each card is connected to up to two Remote Transceivers. The REMOTE TRANSCEIVER Units are

distributed throughout the building as necessary to provide coverage. The Remote Transceivers are mounted, generally, above the suspended ceiling but may be mounted near the ceiling inside the room if need be. The aesthetic and low-profile design of the Remote Power Supply makes it relatively unobtrusive. The plastic cover may even be removed and/or painted to match the décor. Each REMOTE TRANSCEIVER is connected to Hub Shelf via two singlemode optical fibers. Each REMOTE TRANSCEIVER has one RF port which is connected to a user-supplied indoor coverage antenna. This port may also be routed through an N-way RF splitter to provide coverage from a number N antennas for the one Remote Transceiver. This reduces the output power and sensitivity at that Remote Transceiver but, in some cases, this could be the most cost-effective way to provide uniform coverage. The REMOTE TRANSCEIVER is powered by +12 to 24 VDC which can be supplied by the customer or by the Remote Power Supply. This is a universal AC power supply with battery backup and is installed with the REMOTE TRANSCEIVER on a wall mounting bracket supplied with the unit. If DC power is supplied by the customer, it can be distributed from a power supply at the Hub location using the conductor pairs in a composite fiber/conductor cable. The DC connector utilized at the Remote Transceiver can accommodate up to 14 AWG wire.

The OFFICECELL design is very versatile but certain options are available that target specific signal types and applications. In addition to the single band versions, there is an 800 MHz/1900 MHz dual band and a GSM900/GSM1800 dual band option. There is also a high power 800MHz and GSM900 option. This option provides a +22 dBm single carrier output for GSM900 or, for 800 MHz, 10 carriers of IS-136 at +10 dBm/carrier or +12 dBm for single carrier CDMA. The system performance is specified for 4 dB optical loss.

OFFICECELL installation and setup is very simple. First, standard telcom grade singlemode fiberoptic cable that is most suitable for the site is installed. The cable installer can terminate the cable on site easily with the OptoClip optical connectors. The Plug-Ins and Remote Transceivers of a given type are completely interchangeable. The OptoClip plugs directly into the Remote Transceiver at one end. The other end plugs into an optical patch panel or directly into the Hub Shelf via an OptoClip-to-SC/UPC adapter. If the patch panel is used, OptoClip-to-SC/UPC jumpers must be used to connect the HUB SHELF to the patch panel. Built-in optical loss compensation automatically equalizes the gain in both the transmit and receive paths so the transmit RF power is known for a given input RF power and the receive path sensitivity is optimized. The only adjustment available is a manual setting for the static transmit power at the Remote Transceiver which may be used to optimize coverage, if necessary. This is a one time adjustment during set up.

1.2.1 Basic Principles

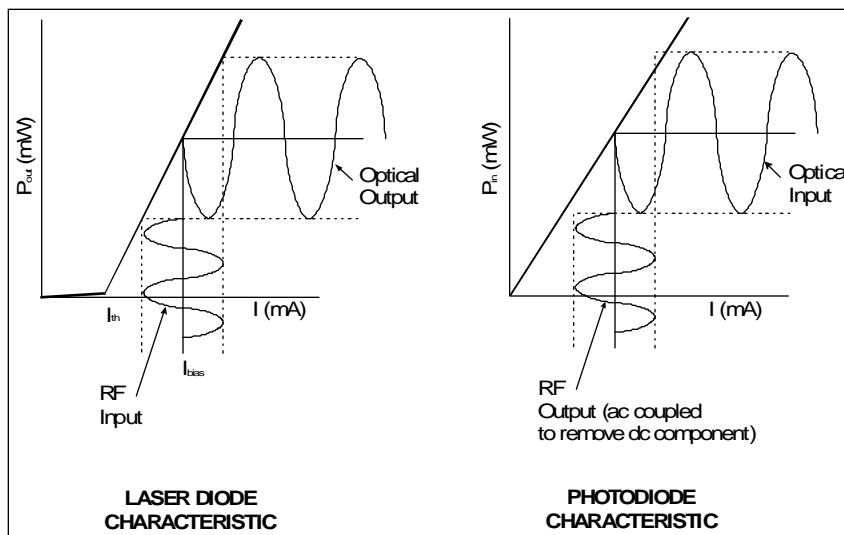

The OFFICECELL operation is based on an analog RF fiberoptic link. The principles are illustrated in Figure 1. Input RF signals are converted to light by direct intensity modulation of a semiconductor laser. This modulated light is transmitted over optical fiber and detected by a semiconductor PIN photodiode. The photodiode converts optical power to electrical current. This current is AC coupled

Figure 0. Laser diode and photodiode characteristics illustrating the operation of an analog fiberoptic link.

and passed through a load to recover the RF signal.

The basic RF loss in this link is determined by the inefficiencies of the conversions of RF to optical and back. The fiber also contributes an RF loss equal to twice the optical loss. This is because the photodiode converts optical *power* to electrical *current* and RF power is proportional to the square of the current. So, for 1 km of fiber with a loss of 0.4 dB/km (this is typical at 1310 nm wavelength) the optical loss is 0.4 dB and the contribution to the RF loss is 0.8 dB. In a real installation, two optical connectors will add approximately 0.5 dB of optical loss.

The laser and, to a much lesser degree, the photodiode, add noise and distortion to the RF signal. This RF performance is characterized just as any RF link in terms of dB loss, noise figure, third order intercept, etc.

The fiber path itself can contribute noise and distortion. In the OFFICECELL, the laser used is a Fabry-Perot (FP) laser instead of a Distributed Feedback (DFB). The DFB has a single spectral component. The FP laser has multiple spectral components which can contribute noise and distortion for longer fiber runs. For the distances used in the OFFICECELL, this effect is not significant. Also, optical backscattering back into the laser from less than perfect connections can cause additional noise and distortion. The FP lasers used in the OFFICECELL are much less sensitive to this than are DFB lasers. DFB lasers are also considerably more expensive. However, if optical reflections are severe enough from a bad connection, the resulting optical reflection may cause performance degradation. To minimize this, SC/UPC optical connectors with a return loss > 50 dB are used at the Hub Shelf and OptoClip connectors with a return loss of > 60 dB are used at the Remote Transceiver. Following standard practices in cleaning of the removable optical connectors (see procedure outlined below) will keep the connections in spec and will avoid the problems of performance degradation.

1.2.2 Functional Description

The OFFICECELL Fiberoptic Antenna System connects to the mobile coverage RF ports of a repeater or

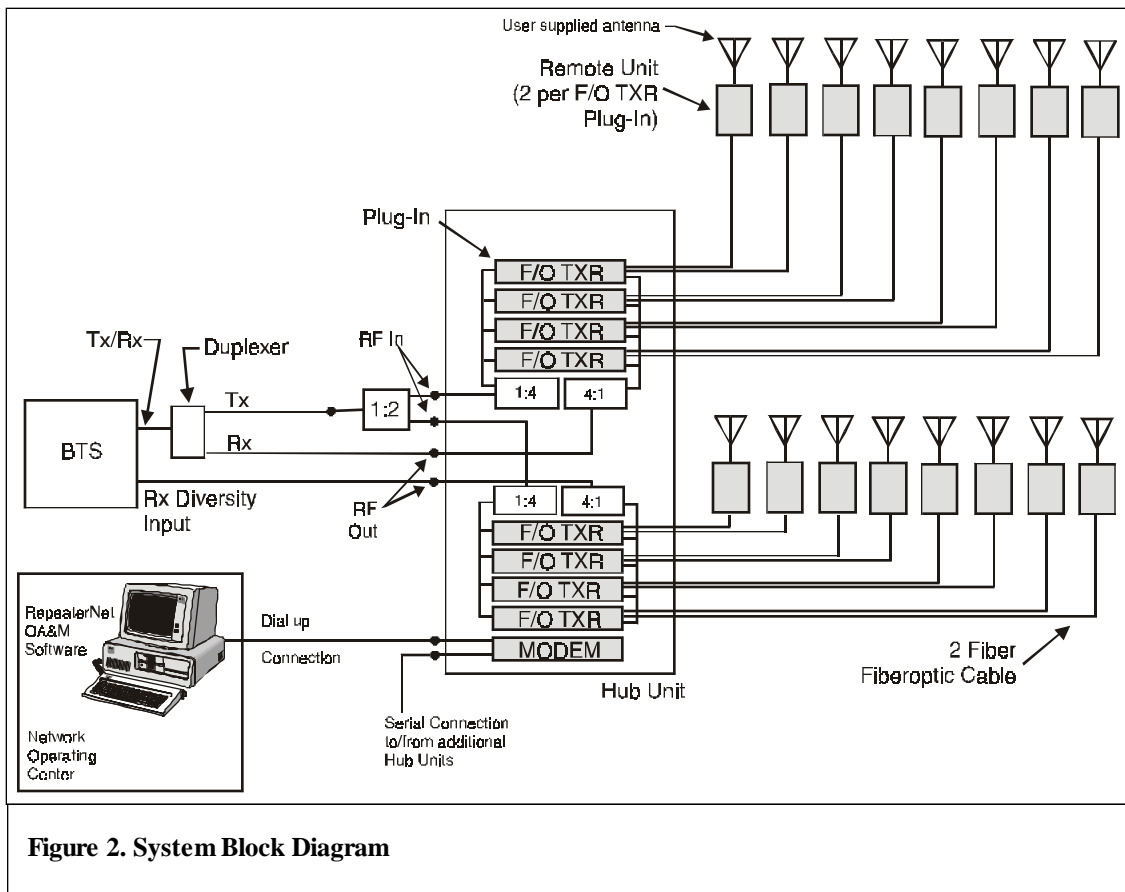

base station as an extended coverage antenna. The Hub Shelf mounts in a standard 19 inch rack close to the repeater or base station transmit and receive RF ports. These RF connections are made via the RF connectors on the rear panel. Inside the chassis, the transmit signal is split and routed to the Hub Transceiver Plug-Ins. Each plug-in is a fiberoptic transceiver. The Hub Shelf holds up to eight plug-ins. Each plug-in interfaces with up to two Remote Transceivers by way of fiberoptic connections on the Hub Shelf rear panel.

The HUB TRANSCEIVER Plug-Ins are connected to the Remote Transceivers via singlemode fiber at 1310 nm wavelength. Separate fibers are needed for the transmit and receive signals. SC/UPC optical connectors (SC/PC snap-in connectors with an “ultra-polish”) are used at the Hub Shelf. These connectors are used because they are compatible with the optical blindmate connectors used on the HUB TRANSCEIVER Plug-Ins. The bulkhead connectors are polished to a return loss of > 50 dB.

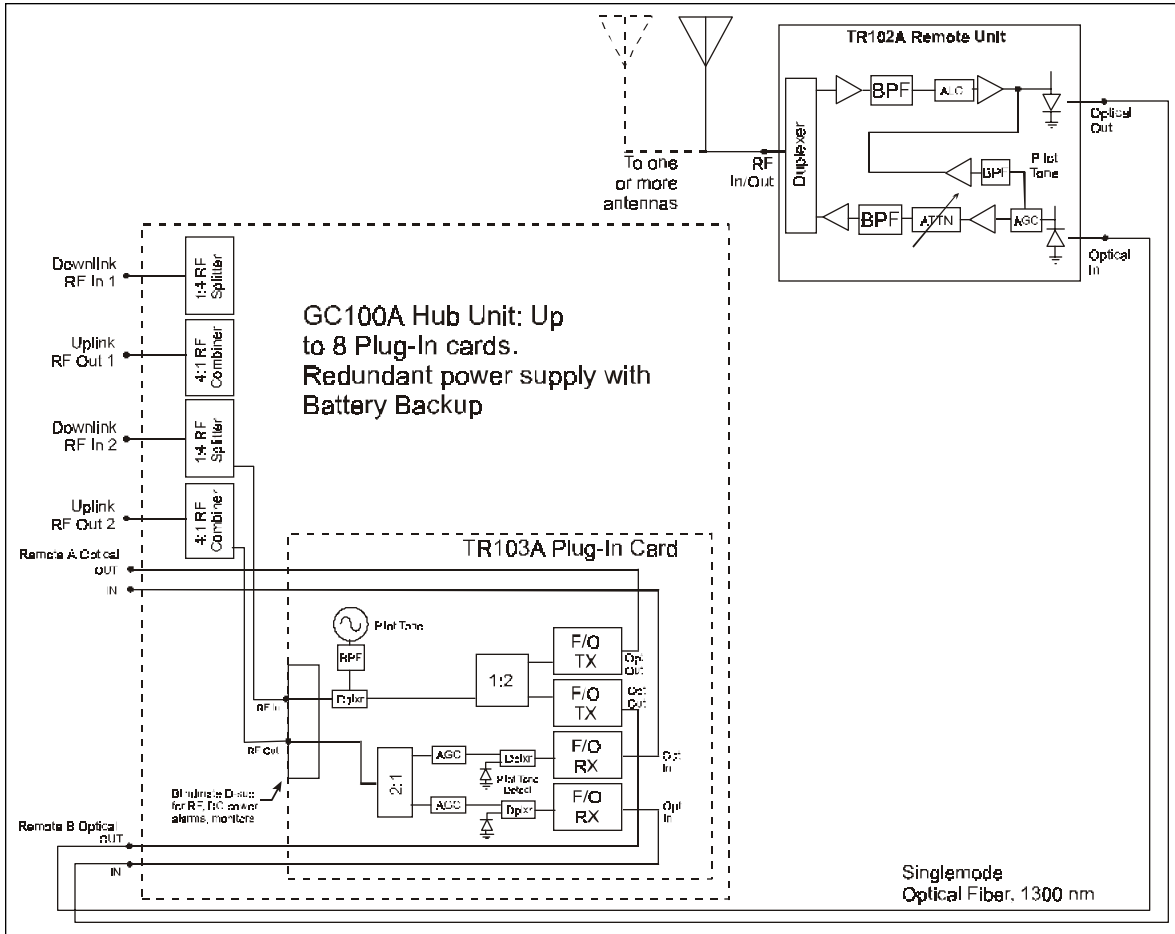

Figure 3. OfficeCell RF Path Block Diagram.

The Remote Transceiver is a fiberoptic transceiver that connects to an external indoor coverage antenna. Depending on coverage and cost requirements, an RF splitter may be used to connect the Remote Transceiver to two or more antennas. The Remote Transceiver uses field-installable OptoClip II optical connectors. The Remote Transceiver optical output is the green connector. The REMOTE TRANSCEIVER units are generally mounted above the false ceiling on a bulkhead or post. Each REMOTE TRANSCEIVER is connected to an indoor coverage antenna by way of a customer-supplied flexible RF cable. Some indoor antennas are available with flexible RF cable pigtailed and an SMA connector termination. These units are distributed throughout the building or campus as necessary to get full coverage. After installation, the transmit power from each Antenna Unit may be adjusted manually by way of a potentiometer on the unit. This is

potentiometer indented in 2 dB steps. This is a one time adjustment. For dual band units, there is a separate adjustment for each band.

Several versions of the REMOTE TRANSCEIVER are available that are optimized for specific formats such as DAMPS, GSM900, GSM1800, etc. Dual band versions are available; one providing simultaneous coverage for GSM900 and GSM1800 and one for PCS1900 and 800 MHz. In these versions, a single RF port feeds a dual band antenna.

The block diagram of the OFFICECELL Fiberoptic Antenna System is shown in Figures 2 and 3. The input transmit RF signal is split eight ways in the Hub Shelf. Each of these signals is routed to a Hub Transceiver Plug-In where it is split in two and each path modulates the optical output of a solid state laser diode. This optical output is routed through a singlemode optical fiber to one Remote Transceiver. The photodiode in the REMOTE TRANSCEIVER detects this optical signal and outputs a proportional electrical current. This current is ac coupled and passed through a load to recover the RF signal. The RF signal is amplified, filtered and output to the antenna. The output RF signal path includes a variable attenuator to adjust the output level for optimum coverage. The RF subcarrier is detected at the photodiode output. This level is used by the transmit AGC to set the downlink gain. The subcarrier is also amplified and inserted into the uplink path. This signal is detected at the Hub Shelf Plug-In for the uplink AGC and Node Function Alarm. A failure of any amplifier in the downlink path in the Remote Transceiver, shuts off the subcarrier in the return path which, in turn, triggers the Node Function Alarm at the Hub.

The receive or uplink RF signal from the antenna is filtered and amplified then routed to the Remote Transceiver laser. A fast ALC is included in this path which prevents RF overdrive damage to the laser while recovering fast enough to minimize blocking for TDMA and GSM signals. The laser output in the Remote Transceiver is then modulated by the receive RF signal and is transmitted through another singlemode optical fiber back to the Hub Shelf Plug-In. Each of the two photodiodes in the Hub Transceiver Plug-In recovers the RF signals from each of two Remote Transceivers. The pilot tone on each signal is split off and detected. This is used for the Node Function alarm. This LED is normally green and turns red if the pilot tone is not detected. This alarm also appears at the

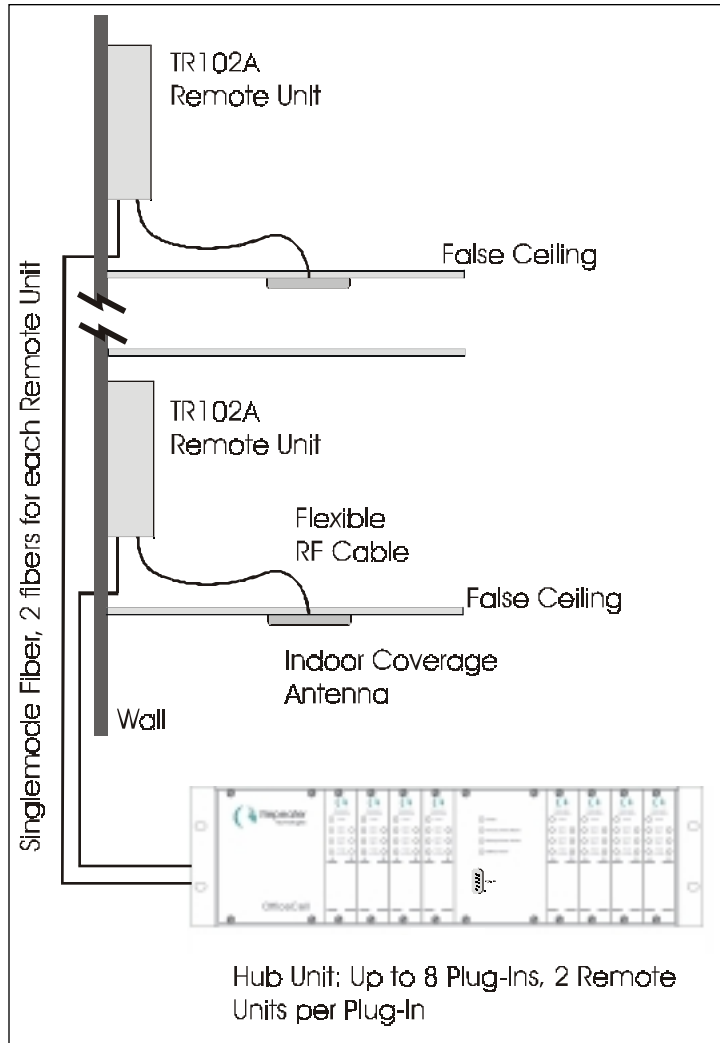

Figure 4. The Remote Transceivers are normally mounted above the false ceiling but may be mounted in the room. Each Remote Power Supply is connected to the Hub Shelf via 2 singlemode fibers. The Remote Power Supply is connected to a user-supplied antenna via flexible RF cable. The Remote Transceivers may be powered using the optional universal Remote Power Supply with battery backup, or using a central power supply that distributes DC power along with the fiber over a composite fiber/conductor

Hub Shelf rear panel DB37 connector as a TTL level critical alarm. It would also be reported to the NOC or service technician by the modem card depending on how the user configured the system alarms.

The receive RF signal from each photodiode is combined in the HUB TRANSCEIVER Plug-In. These combined outputs are combined again in the and output to the rear panel RF uplink connectors. The Hub Shelf is divided into two halves. The RF signals from each half are combined and routed to separate rear panel N connectors. The combined uplink signals from one half can be routed to the BTS main receive port while the other RF output is routed to the BTS receive diversity port. This method provides an overall 3 dB system sensitivity improvement compared to routing all of the uplink signals into one receive port (see Figure 2). Alternatively, both outputs may be combined and routed to a single BTS receive port.

1.3 Specifications

Description

This specification defines the uplink and downlink performance of the OfficeCell Fiberoptic Antenna System. The terminal equipment consists of the Remote Transceiver and the Hub Transceiver Plug-In. The latter is installed in the Hub Shelf. This system meets and exceeds the requirements for GSM900, GSM1800 and GSM1900 Class M3 micro-BTS as well as IS-136 TDMA and IS-95 CDMA for wireless PBX, in-building and campus coverage applications.

There are four frequency options for the OfficeCell: 850 MHz (AMPS), GSM900, GSM1800 and PCS1900. There are two downlink output power options: the P1 power option meets GSM 900 micro-BTS M3 requirements and is available for the 850MHz and 900MHz versions only. The P2 power option meets micro-BTS M3 requirements for 1800MHz and 1900MHz. For 850MHz and 900MHz, the High Power meets GSM micro-BTS power class M1 requirements and IS-136 in-building requirements for +20 dBm composite power. All of these system standards specifications are met for optical loss of up to 4 dB.

RF Parameters (up to 4 dB optical loss)

Uplink

Frequency Range	850 MHz GSM900 GSM1800 PCS1900	824 - 849 MHz 890 - 915 MHz 1710 - 1785 MHz 1850 - 1910 MHz
Amplitude Flatness	824 – 849, 890 - 915 MHz; Full band (Any 15 MHz band)	± 1.5 dB ± 1.0 dB
	1710 – 1785, 1850 - 1910 MHz; Full band (Any 15 MHz band)	± 2.5 dB ± 1.0 dB
Noise Figure	Low Noise Option	≤ 13 dB ≤ 7 dB
Input Third Order Intercept (IIP3), 2 carriers, -43 dBm/carrier	Low Noise Option	≥ -15 dBm ≥ -25 dBm
Link Gain (with external 20 dB attenuator; 30 dB attenuator with Low Noise Option)	824 - 915 MHz 1710 - 1910 MHz	4 ± 1 dB 4 ± 1 dB
Uplink Input ALC	Input RF Threshold	- 25 dBm
	Low Noise Option	-35 dBm
	Range	30 dB
	Response Time	< 5 μsec w/o ringing
Gain Stability		± 1 dB
Input/Output Impedance		50 Ω
Input/Output VSWR		≤ 2 : 1

Downlink

Frequency Range	850 MHz GSM900 GSM1800 PCS1900	869 - 894 MHz 935 - 960 MHz 1805 - 1880 MHz 1930 - 1990 MHz
-----------------	---	--

Amplitude Flatness

869 – 894, 935 - 960 MHz; Full band	± 2.5 dB
(any 15 MHz band)	± 1.0 dB
1805 – 1880, 1930 - 1990 MHz; Full band	± 2.5 dB
(any 15 MHz band)	± 1.0 dB
Output Noise	≤ -92 dBm/Hz
Output Third Order Intermodulation Product	
(Interfering CW carrier 30 dB below main carrier,	
for single carrier at max output power)	≤ -38 dBm
2 Equilevel Carriers at +17 dBm/carrier	≤ -42 dBc

Output Power, Maximum (dBm)

	Std	Single Carrier	2 Equilevel Carriers (Power/Carrier)
P1	GSM	+14	+5
	IS-136	+12	+9
	CDMA	+4	+1
P2	GSM	+22	+13
	IS-136	+20	+17
	CDMA	+12	+9

Output Power Range ≥ 12 dB user adjustable (in 2 dB increments at TR102 Remote Transceiver)

Input Power Threshold for Input Power Protect 8.5 to 11.5 dBm
Attenuation Step for Input Power Protect 10 dB

Gain at Maximum Output Power (output attenuator set at min)
Output Power Option P1 2 ± 1 dB
Output Power Option P2 14 ± 1 dB

Gain Stability ± 1 dB
Input/Output Impedance 50 Ω
Input/Output VSWR ≤ 2 : 1

General

Loop back Carrier Frequency 99 MHz ± 10 MHz

Optical Parameters

Wavelength 1310 ± 20 nm
Output Power
Remote Transceiver 1.8 mW
Hub Transceiver Plug-In 1.8 mW
Optical Connector
Hub Shelf SC/UPC, > 50 dB return loss
Remote Transceiver Optoclip II®, > 55 dB return loss
Fiber Singlemode

Absolute Maximum Ratings

RF Input Power
Uplink +5 dBm
Low Noise Option -5 dBm
Downlink +26 dBm total
Photodiode Input Optical Power +2.3 mW

Electrical

Remote Transceiver	+12 V to +24 V, 12 W (single band), 20 W (dual band)
Remote Power Supply	100 to 240 VAC, 47 – 63 Hz
Hub Transceiver Plug-In	6 W
Hub Shelf	100 - 240 VAC, 47 - 63 Hz

Mechanical

Remote Transceiver

See outline drawing below

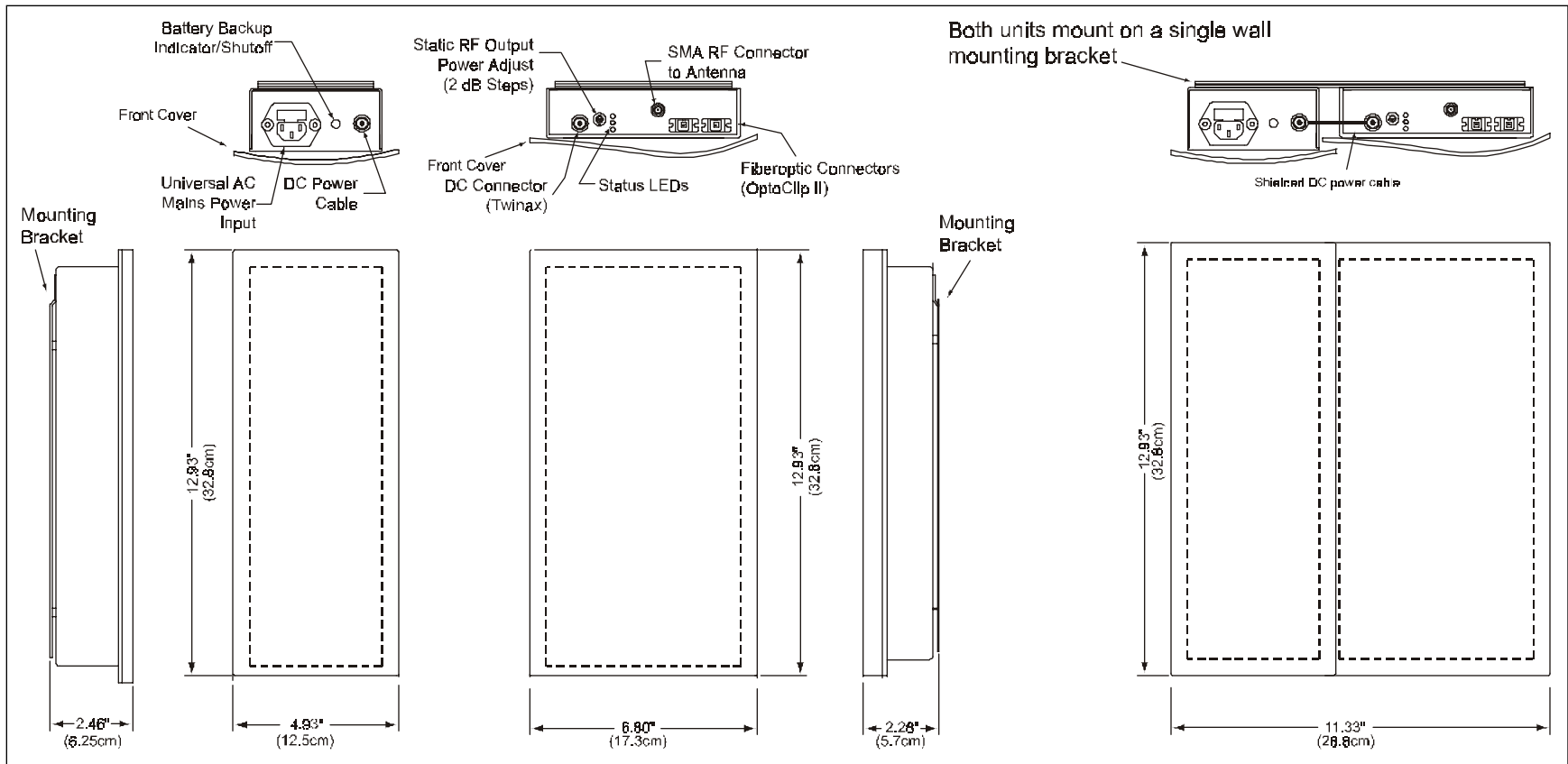

Hub Shelf Plug-In (HUB TRANSCEIVER) Plug-in card with 5.06" H x 1.2" W front panel for HUB SHELF Chassis.

Hub Shelf (HUB SHELF) 19", 3U (5.25") H, 15.75" D rack mount

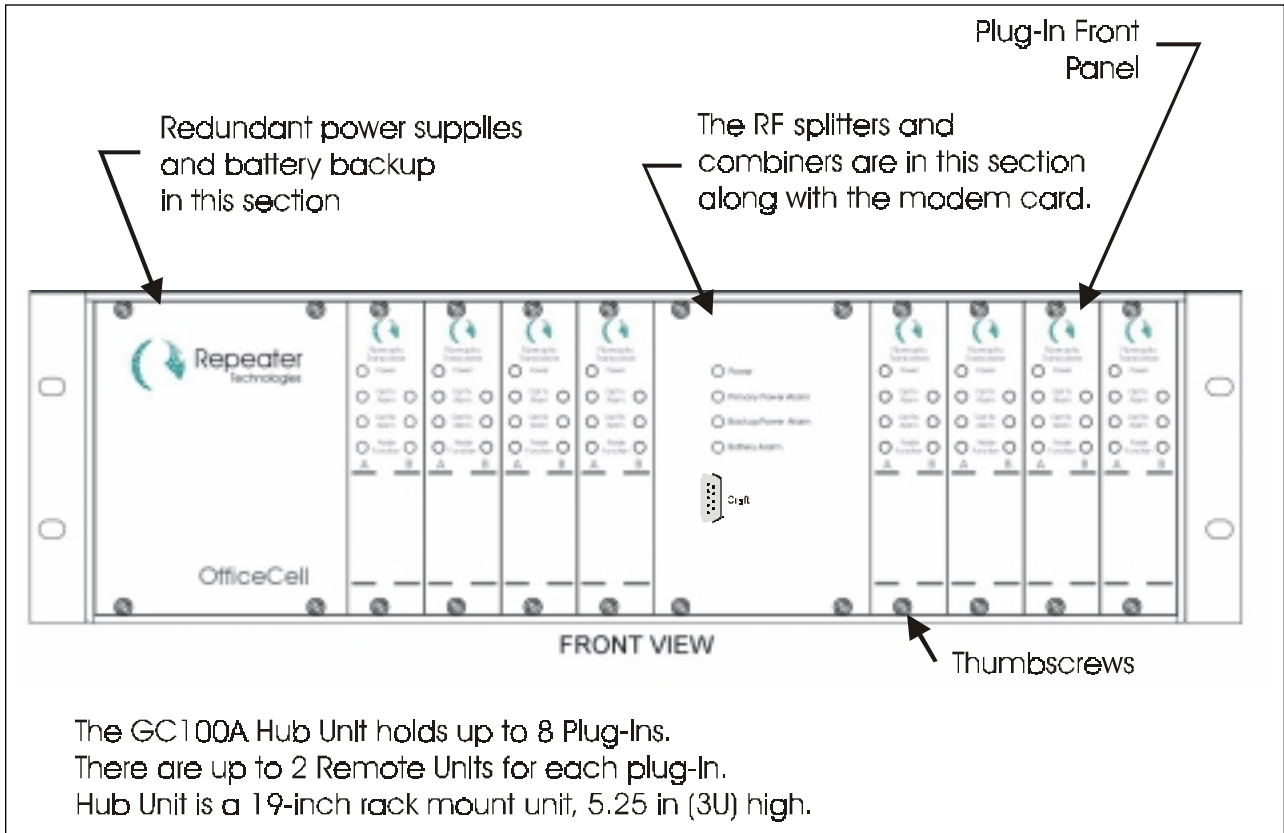

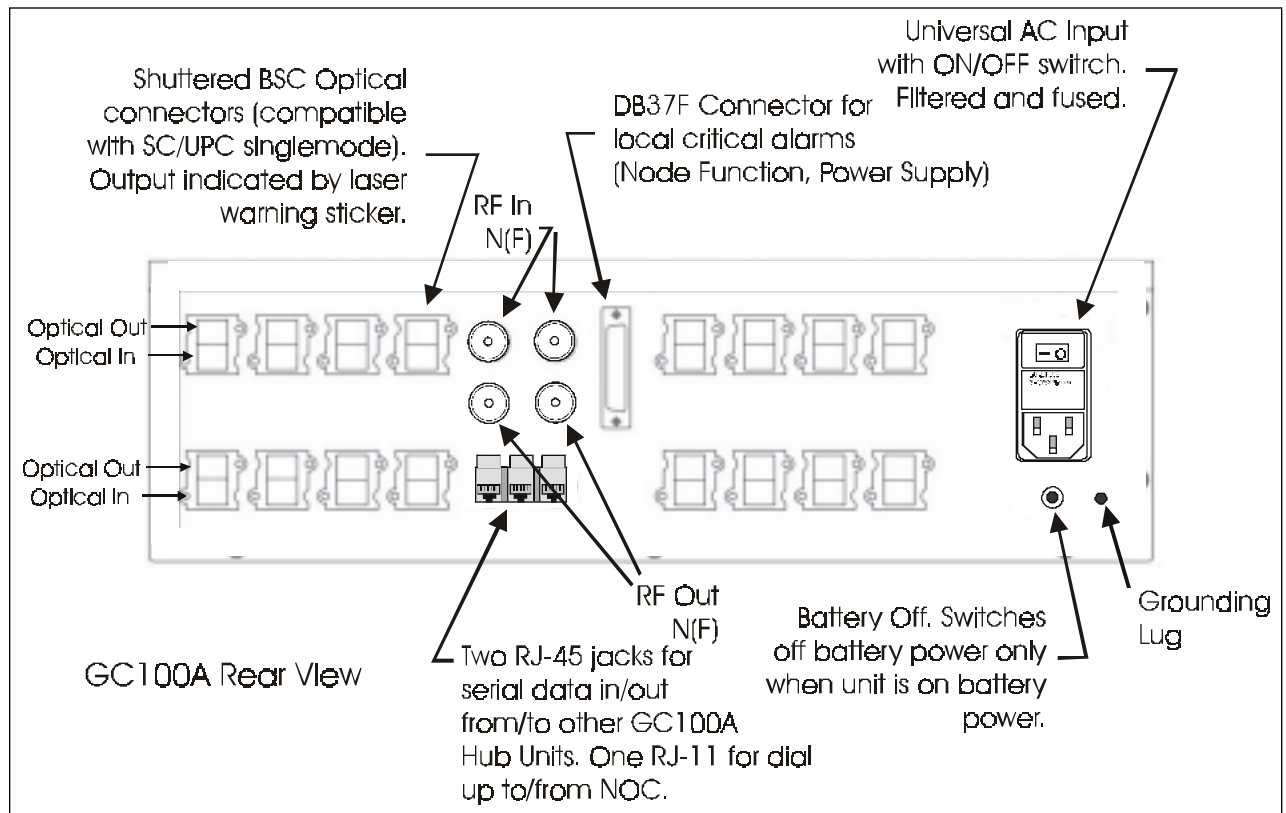

Alarms and Monitors

Remote Transceiver

<i>Description</i>
Power On (Green LED)
Laser Optical Power Low Alarm (active if laser output < 90% of factory set point: Red Front panel LED)
Received Optical Power Low Warning (active if optical loss > 4.2 dB: Yellow front panel LED)
Transmit Amplifier Failure Alarm (active if any amplifier in transmit path fails as detected by bias current: Red LED. Also causes shutoff of subcarrier in uplink path which triggers Node Function Alarm at plug-in.)

Hub Transceiver Plug-In

Node Function (loopback carrier detect: Front panel LED; normally Green, Red if RF subcarrier level drops more than 10 dB)
Received Optical Power Low Warning (active if optical loss > 4.2 dB: Yellow front panel LED, normally OFF)
Laser Optical Power Low Alarm (active if laser optical output power drops 10%): Red Front panel LED, normally OFF)

Hub Shelf

LEDs

Power On (Green, Normally ON)
Main Power Alarm (Red Front panel LED; normally OFF)
Backup Power Alarm (Red Front panel LED; normally OFF)
Battery Alarm (Yellow front panel LED, active if battery backup charge is low; normally OFF)

Alarms, Rear Panel DB-37 (See Table)

Critical Alarms: these include all Node Function Alarms and the Main and Backup Power Supply Alarms.
Summary Contact Closure Alarm: active if any alarm is active in chassis or plug-ins.

RepeaterNet

Any critical alarm prompts the system to dial up Remote Power Supply NOC. This is configured at installation with a laptop computer via the front panel Craft interface. Dial up connection is made with RJ-11 interface on rear panel. The system may also be polled through dial up connection to get status of all alarms and warnings.

Craft Interface (Front Panel)

Used to set up RepeaterNet interface. Includes setting telephone number of master Hub Shelf as well as the NOC or service pager. Also configures Hub Shelf as master or slave. Master provides dial up

connection for itself and daisy-chained slave units.
 Connection to slave units via RJ-45 jacks on rear.

DB-37 Pin	Signal name	Type	Sense
1	1-A Node Function Alarm	TTL	Active Low
2	2-A Node Function Alarm	TTL	Active Low
3	3-A Node Function Alarm	TTL	Active Low
4	4-A Node Function Alarm	TTL	Active Low
5	5-A Node Function Alarm	TTL	Active Low
6	6-A Node Function Alarm	TTL	Active Low
7	7-A Node Function Alarm	TTL	Active Low
8	8-A Node Function Alarm	TTL	Active Low
9	Master P.S. Alarm	TTL	Active Low
10	Battery Alarm	TTL	Active Low
11	n.c.		
12	n.c.		
13	n.c.		
14	n.c.		
15	RTN		
16	RTN		
17	RTN		
18	n.c.		
19	n.c.		
20	1-B Node Function Alarm	TTL	Active Low
21	2-B Node Function Alarm	TTL	Active Low
22	3-B Node Function Alarm	TTL	Active Low
23	4-B Node Function Alarm	TTL	Active Low
24	5-B Node Function Alarm	TTL	Active Low
25	6-B Node Function Alarm	TTL	Active Low
26	7-B Node Function Alarm	TTL	Active Low
27	8-B Node Function Alarm	TTL	Active Low
28	Back-up Power Supply Alarm	TTL	Active Low
29	n.c.		
30	n.c.		
31	n.c.		
32	n.c.		
33	n.c.		
34	Summary Alarm N.C.	Relay contact	Connect to Common if O.K.
35	Summary Alarm Common	Relay contact	
36	Summary Alarm N.O.	Relay contact	Open if O.K.
37	n.c.		

Environmental

Operating (ETSI EN 300 019-1-3)

Temperature Range +5 to +45EC
 Rate of Temperature Change 0.5 °C/minute
 Relative Humidity 5 to 85% RH, non-condensing

Storage and Transportation

(ETSI 300 019-1-1 STORAGE, class 1.2)

(ETSI 300 019-1-2 TRANSPORTATION, class 2.3)

Temperature Range -40 to +70°C
 Rate of Temperature Change 0.5°C/minute
 Relative Humidity 10 to 100%

Vibration (Storage)

PARAMETER	FREQUENCY RANGE (Hz)	SEVERITY		DURATION
		Vel; mm/s	Accel; m/s ²	
Sinusoidal	5 – 62	5.0		3x5 sweep cycles
Sinusoidal	62 - 200		2	3x5 sweep cycles

Vibration Test (Transportation)

PARAMETER	FREQUENCY RANGE (Hz)	SEVERITY		DURATION
		ASD: m ² /s ³	Rolloff: dB/oct	
Random	5 – 20	0.96		3 x 10 mins
Random	20 - 500		-3	3 x 10 mins

Shock Test (Transportation)

PARAMETER	SHOCK SPECTRUM (Hz)	SEVERITY		DURATION ms
		Accel: m/s ²	Number	
Shock (m≤100kg)	Half Sine	400	500 in each of 6 directions or 1000 in normal attitude	6

Drop Test (Transportation)

PARAMETER	MASS (kg)	DROP HEIGHT (m)	NUMBER OF DROPS
Free Fall	< 30	0.5	1 on each face or 2 in normal attitude
Free Fall	30 - 40	0.4	1 on each face or 2 in normal attitude
Free fall	40 - 50	0.3	1 on each face or 2 in normal attitude

Regulatory

UL, CSA, FCC Type
 Acceptance for 800 MHz
 and PCS versions.
 CE Mark for GSM900 and
 GSM1800 versions

2 Installation

2.1 General Procedure

Before installing and, in fact, before even receiving the OfficeCell units, one can have the fiberoptic cables installed and tested. The network planning has been completed which has determined the type, number and location of Remote Transceivers needed for optimum coverage and capacity.

Install and check the fiberoptic cables first. Use any high quality, telcom grade singlemode fiberoptic cable. The OptoClip II optical connectors are installed easily on site (contact Molex or Huber+Suhner for installation kits and training for the OptoClip II). General practice is to terminate the fiberoptic cables at a patch panel near the Hub Shelf. In this case, optical jumper cables will be needed to make the connection between the patch panel and the Hub Shelf. These jumpers will be terminated with an OptoClip II connector at one end and an SC/UPC at the other.

! Make sure to specify SC/UPC, not SC/PC. The standard SC/PC has an optical return loss < 27 dB which can cause degradation of the system noise performance. SC/UPC specifies an “ultra” polish for a return loss > 50 dB.

During this process, label each cable at each end to indicate whether it is transmit or receive and which Remote Transceiver it is associated with. It is good practice to pull one or two additional fiber pairs to each Remote Transceiver to allow for future expansion. Next, mount the Hub Shelf in the rack and connect the fiberoptic cables. Do not connect the RF cables yet.

Mount the Remote Transceivers. Install the wall mounting brackets first. For mounting above a false ceiling, orient the bracket so that the end of the Remote Transceiver with the connectors is pointing downwards. When mounting inside the room, place the Remote Transceiver near the ceiling with the connectors pointing upwards. This permits the most aesthetic routing of the cables. The plastic cover on the Remote Transceiver may be removed by loosening the four screws on the back of the Unit. This permits the user to paint the cover to match the room décor. If the REMOTE TRANSCEIVER is to be installed with the Remote Power Supply, install the two mounting brackets next to each other linking them with the connector piece supplied with the power supply mounting bracket. This will give the most aesthetic mounting with the proper spacing for an easy DC power connection. Orient the bracket so that the threaded tab will be at the same end as the connectors on the REMOTE TRANSCEIVER. Place the REMOTE TRANSCEIVER so that the rear panel studs slide into the keyhole slots on the mounting bracket. Secure the unit by tightening the captive thumbscrew on the REMOTE TRANSCEIVER to the threaded hole in the mounting bracket. The Remote Power Supply installs in the same way. For the Remote Power Supply, if the red NO AC LED is on, press the reset switch located next to the AC power connector which turns off the battery backup (when the mains is not connected). For AC powered units, connect the AC power cords to the building mains according to local building electrical codes. Connect DC power to the REMOTE TRANSCEIVER by connecting the shielded cable with the twinax termination to the DC input connector on the REMOTE TRANSCEIVER.

Mount the indoor coverage antenna to the ceiling or wall as needed and connect it to the Remote Transceiver with a flexible RF cable. The RF cable must have an SMA male connector for the connection to the Remote Transceiver. If the antenna has a different RF connector, say, N or TNC, an RF adapter must be used. Plug in the transmit (downlink) fiberoptic cable connector into the OPTICAL IN on the Remote Transceiver and the receive (uplink) fiberoptic cable connector into the OPTICAL OUT (Green) on the Remote Transceiver.

From the initial network design, the output power required from each Remote Transceiver should be known. This can be preset before power is turned on by turning the Output Power adjustments on each Remote

Transceiver. From the maximum output power rating for each Remote Transceiver, the power can be reduced in 2 dB using the indented potentiometer.

Turn the power on to the Remote Transceivers and on the Hub Shelf. Proper operation of the optical system is indicated by a green Node Function LED on each of the Hub Transceiver Plug-Ins that is connected to an active Remote Transceiver. All other alarm indicators should be OFF. A yellow LED at the plug-in or at the Remote Transceiver indicates that the optical loss in that path is > 4 dB and is, therefore, out of the range of the guaranteed specification.

Before connecting the Hub Shelf to the BTS or Repeater, check that the RF transmit power from the source (BTS or repeater) is within the safe operating range of the OFFICECELL and that it is at the level required for proper noise and distortion performance according to the network design (see Table 1).

Table 1. Transmit (Downlink) Input RF Levels/carrier

	GSM (05.05)	TDMA (IS-136)	CDMA (IS-95)
800MHz/900MHz	+12 dBm, 1 carrier	+11 dBm, 2 carriers	+3 dBm, 1 carrier
Power P1 (2 dB gain)	+4 dBm, 2 carriers	+8 dBm, 4 carriers	0 dBm, 2 carriers
GSM1800/1900MHz,	+8 dBm, 1 carrier	+3 dBm, 4 carriers	-2 dBm, 1 carrier
800MHz/GSM900	-1 dBm, 2 carriers	0 dBm, 8 carriers	-5 dBm, 2 carriers
Power P2 (14 dB gain)	-4 dBm, 4 carriers	-3 dBm, 10 carriers	-8 dBm, 4 carriers

Connect the RF cables between the BTS or repeater and the Hub Shelf. The Remote Transceivers and the plug-ins have been calibrated at the factory and the optical loss compensation in each Remote Power Supply and plug-in automatically equalizes the gain in each link so that the specified link gain is always met. The system is now operational and no further adjustment is necessary.

Fiberoptic Antenna System Installation for In-Building Coverage

TR102A Remote Unit.
Mounted Above False Ceiling
on Wall or Post.

AC Version (shown) uses universal AC adapter.
DC Version: can use composite fiber/copper cable.

All Status LEDs, Output Power Adjust,
RF and Optical Connectors on Bottom
End of TR102A Unit for Convenient Access
When Moving Ceiling Panel Aside.

Flexible RF
Cable Connects
Antenna Unit to
Indoor Coverage
Antennas.

Antenna Unit Connects to All
Standard Indoor Coverage Antennas.

1310 nm, Singlemode
Fiberoptic Cable: Up to 4 dB
optical loss. 2 fibers per Remote.

Link compensation
in the plug-in and Remote
automatically equalizes gain
for every link.

Hub Unit Status LEDs:
Node Function OK, Laser Alarm, Received Optical Power,
Power On, Main and Backup Power Supply Alarms,
Battery Backup Charge.

Uplink and
Downlink RF
Connection to
Repeater or BTS

Labels for User-Defined
Names for Remote Node
Locations Can Be Affixed
On Plug-In Front Panels
in Silk-Screened Boxes.

GC100A Hub Unit.
Each Plug-In Handles 2 Remote Units.
Up to 8 Plug-Ins/Chassis, 16 Remotes.
All Cables Connect at Rear Panel.

2.2 Install Fiberoptic Cables

Once the location for each of the Remote Transceivers has been determined, the fiberoptic cable can be installed between the Hub Shelf and these locations. The cable length can be up to 5 km.

You need to know the following:

Optical Fiber	Singlemode, 1310nm wavelength
Optical Loss	Good quality fiber should have an optical loss of < 0.4 dB/km at 1310nm. There will be additional optical loss due to connectors and splices but there should be no more than about 0.5 dB loss through a connector mating (optical connections are sexless) and less through a splice.
Optical Connectors	OptoClip II [®] connectors. These connectors are easily installed on site. Contact Molex or Huber+Suhner for installation kits and training. The Hub Shelf uses SC/UPC connectors so an OptoClip-to-SC/UPC adapter must be used. Alternatively, connect the Hub Shelf to an OptoClip patch panel using optical jumpers with an OptoClip termination at one end and an SC/UPC termination at the other. IMPORTANT NOTE: MAKE SURE TO USE AN SC/UPC TERMINATION: THIS CONNECTOR IS AN “ULTRA-POLISHED” CONNECTOR WITH AN OPTICAL RETURN LOSS > 50 dB. A STANDARD SC/PC TERMINATION HAS A HIGH RETURN LOSS AND WILL DEGRADE LINK NOISE AND LINEARITY PERFORMANCE.

Once the cable has been installed, the installer should check the quality of the optical path using an Optical Time Domain Reflectometer (OTDR). This will check the optical path loss and the magnitude and location of any reflections. The total return loss should be > 45 dB.

While checking the cables in this way, it is useful to label each cable near the connector as to which Remote Transceiver it is for and whether it is for the transmit or receive path. Labelling the cable in this way permits complete interconnection during installation with the system powered off. Otherwise, the Remote Transceivers will have to be installed with the Hub Shelf power on with all fiberoptic cables connected to it. This allows the installer to check which fiber is transmit by using an IR sensitive card (see Recommended Tools).

2.2.1 Minimizing Optical Reflections

As discussed in the Functional Description, optical reflections can degrade the noise and linearity of a fiberoptic link. In particular, reflections that reach the laser can be a problem. Keep all discrete reflections to > 45 dB. For the Hub Shelf, the SC/UPC connectors are polished to a return loss >50 dB. At the Remote Transceivers, the OptoClip connectors have a return loss of > 55 dB.

2.2.2 Cleaning Optical Connectors

Optical reflections from a discontinuity such as a poor connector interface appear on an RF spectrum analyzer trace as stable variations in the noise floor amplitude that are periodic with RF frequency. If the reflection is bad enough, it could impact the system performance. By far, the most common cause for a large discrete reflection is a dirty optical connector. Remember that the optical aperture at the tip of the fiberoptic connector is only 9 μ m in diameter. A bit of dust or oil from a finger can easily interfere with or block this light. Fortunately, it very easy to clean the connector. The procedures are indicated in the Figure. Be sure to use the correct procedure for the given connector. When disconnected, cap the SC/UPC connector to keep it clean and prevent scratching the tip of the ferrule. The OptoClip is “self-capping”.

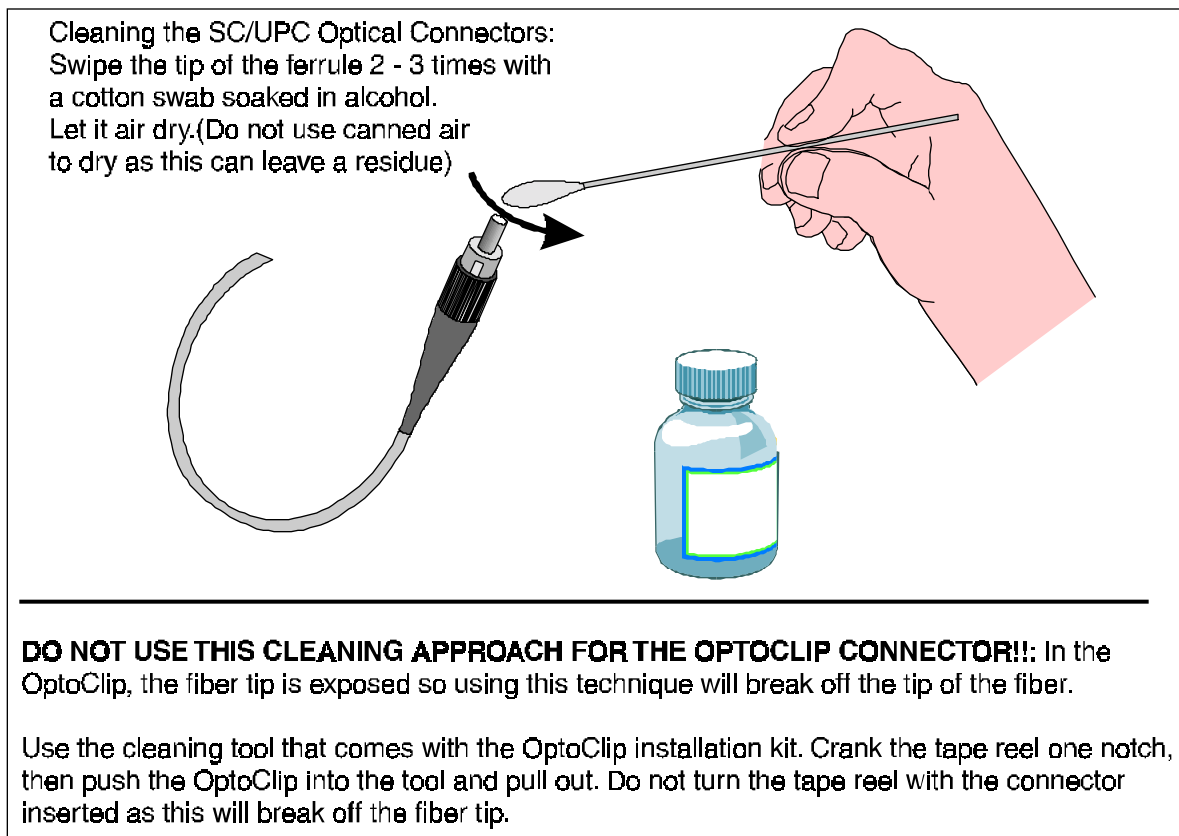

Figure1. Keeping the tip of the optical connectors clean is a simple way to ensure optimum system performance.

2.3 System Alarms

The OfficeCell has three ways of indicating alarms.

1. LEDs: the Hub Shelf and the Remote Transceiver have status indicators for power on and alarm conditions.
2. Hub Shelf Rear Panel DB37 Connector: The “critical” alarms are available here as TTL levels. In addition, three pins provide a contact closure summary alarm (see Alarms in the specifications).
3. Modem connection: The system status may be monitored locally with a computer through the front panel Craft port. The main purpose of this port is to set the system initially. This includes specifying which alarms are critical, setting the local system telephone number and specifying the action to be taken when there is a critical alarm (dial up the NOC or a service technician’s pager). With the RepeaterNet OA&M software, up to 5000 systems can be Remote Power Supply monitored.

Using the alarms provided, the cause of a critical failure can be determined with high confidence. For instance, if the Node Function alarm is associated with a Plug-In laser alarm, the Plug-In has failed and must be replaced. If the Node Function alarm is associated with a Received Optical Power Low at the Plug-In, either the Remote Transceiver laser has failed or the fiberoptic cable has been broken or damaged. The service technician would come with a replacement Remote Transceiver. If, upon inspecting the Remote Power Supply in question, the LEDs indicate no failure, the fiber path would have to be inspected. This should be relatively easy to track down since damage would have to be associated with some other work going on at the site or someone had deliberately disconnected the optical cable from the unit. Finally, a Node Function alarm not associated with any other alarm at the Hub Shelf would indicate a failure of the Remote Transceiver downlink amplifier chain. This would be confirmed by inspection of the Remote Power Supply in question for that particular LED. The complete troubleshooting matrix is given at the end of this manual and can be used to program the OA&M software to recommend the proper action to be taken.

2.4 Hub Shelf and Remote Power Supply Battery Charge Monitoring and Battery Replacement

Both the Hub Shelf and the Remote Power Supply have a battery backup. While connected to mains power, the battery is kept charged by a charging circuit. Once AC mains power is first connected, the charging circuit waits 48 hours before starting the battery test circuit. This circuit checks to open circuit battery voltage every ten seconds. Once the circuit detects the battery voltage drops below approximately 12 Volts, the BATT LOW alarm is activated. At the beginning of life, the battery provides approximately 15 to 20 minutes of system backup. At end of life, the backup time is about 8 to 10 minutes. It is expected that the batteries should be replaced every 1.5 to 2 years.

2.4.1 Replacing the Hub Shelf Battery

The battery must be replaced with the AC mains power off.

1. Turn off the AC mains power (rear panel switch)
2. Disconnect AC mains power cable

3. Press the BATT OFF switch on the rear panel to switch off the battery power to the Hub Shelf
4. Pull the Hub Shelf out of the rack from the front on the chassis rack mount slides. Be careful not to pull on rear panel cable assemblies, especially the fiberoptic cables.
5. Remove the Hub Shelf top cover.
6. Locate the battery on the left behind the power supplies.
7. Remove the battery bracket by loosening the screws. Lift off the bracket.
8. Disconnect the battery terminal wires by pulling them off.
9. Lift the battery out.
10. Install the replacement battery by reversing the process.

2.4.2 Replacing the Remote Power Supply Battery

The battery must be replaced with the AC mains power off.

1. Disconnect the AC mains power cable.
2. Press the BATT OFF switch on the power supply to switch off the battery power.
3. Disconnect the DC power connector from the Remote Transceiver.
4. Loosen the thumbscrew that secures the power supply to the mounting bracket.
5. Slide the power supply housing so as to release from the mounting bracket keyhole slots.
6. Remove the smaller cover on the back of the housing (the far end from the connectors).
7. Lift out the battery and pull off the terminal wires.
8. Install the replacement battery by reversing the process.

2.5 Installation Checklist

Once the fiberoptic cable has been installed properly, the OfficeCell installation and set up is simple.

2.5.1 Inspect Received Items

Inspect all received items thoroughly. If any item has been damaged during shipping, report it to the shipping company and to Repeater Technologies in the U. S. at 408-747-1946. Also, contact the factory immediately if any item is missing.

Packing List Checklist (as applicable)

- Hub Shelf w/mounting hardware and AC power cord
- Hub Transceiver Plug-In (s); these are installed in the chassis unless they are spares
- Plug-In Termination Cards: these are plug-ins behind blank front panels installed on unused slots. They provide 50Ω RF terminations to the internal RF splitters and combiners ensuring a balanced load.
- Two 1:2 RF splitter/combiners (supplied with the Hub Shelf)
- Remote Transceiver (s): These will be in a separate box.
- Remote Power Supplies (not included if user is supplying DC power to REMOTE TRANSCEIVER).
- Mounting Brackets for REMOTE TRANSCEIVER and REMOTE POWER SUPPLY. Included with REMOTE TRANSCEIVER and REMOTE POWER SUPPLY.
- 1 Operating Manual

2.5.2 Recommended Tools

- OptoClip II installation kit
- Fiberoptic Connector Cleaning Kit: *For the SC/UPC:* cotton swabs, alcohol, *For the OptoClip:* OptoClip cleaning tool
- IR sensitive card: used to detect active laser port and active fiber. (eg. Quantex Model Q-42-R)
- Small screwdriver or Adjustment Tool for transmit output power potentiometer
- Screwdriver for mounting chassis in rack and Remote Transceivers on the wall
- 4 #6 panhead or M3.5 mounting screws for each Remote Transceiver.
- Appropriate screws, washers and mounting hardware for rack mounting the Hub Shelf.

2.6 Installing the Hub Shelf

The Hub Shelf mounts in a standard 19 inch rack close to the RF source (BTS or repeater). The chassis should be supported at the sides as well as from the front flanges. The HUB SHELF 3U high chassis is available with rails. Before turning on the AC (or DC) power to the chassis, connect the fiberoptic cables at the rear panel.

During installation of the fiberoptic cables, each fiber should have been labelled as to which Remote Transceiver it is to be connected to and whether it is for transmit or receive. The transmit or downlink fibers are connected to the optical outputs on the rear panel. These are the red connectors with the laser light warning labels. Make sure that the connectors used are associated with an active plug-in installed in the chassis.

For ease of installation, the cable has been terminated with the OptoClip optical connector. The optical

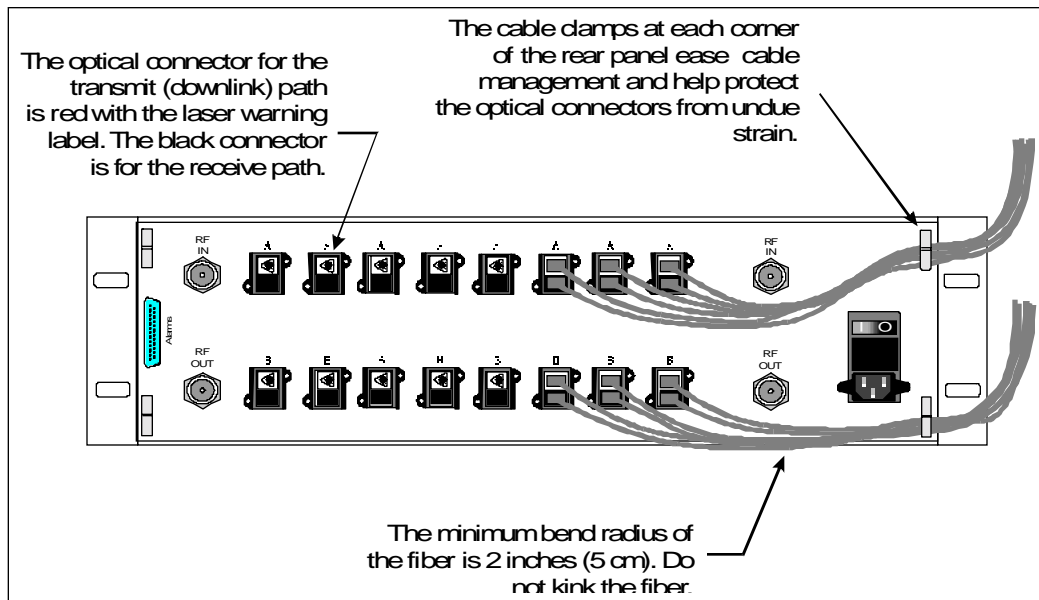

Figure 0. Connecting Fiberoptic Cables to Hub Shelf.

connectors for the Hub Shelf are SC/UPC so an OptoClip-to-SC/UPC adapter must be used. Alternatively, use optical jumpers with an SC/UPC termination at one end and an OptoClip at the other to connect the Hub Shelf to an optical patch panel (recommended). First, clean the tip of the connector on the cable according to the procedures in 2.2.2 above. Lift the spring loaded cover on the Hub Shelf rear panel connector and push in the SC/UPC cable connector until firmly seated (the connector may or may not “click” into place; do not push too hard). You may want to use the cable clamps located on the four corners of the rear panel to manage and protect the cables.

The front panel of each Plug-In has two 1.75” x 0.5” (4.4 cm x 1.3 cm) outlines labelled A and B which can be used to affix standard “address” size labels (Avery 5167) to designate which Remote Transceiver is connected to that path.

Do not connect the RF cables yet.

If more than one Hub Shelf is being used, connect the SERIAL DATA ports together using CAT-5 jumpers with RJ-45 connectors. The two SERIAL DATA ports on the rear panel are connected together; two are provided to permit the use of simple jumpers when daisy-chaining several units.

Connect the LINE port to a POTS telephone jack for the dial-up modem connection.

If it is being used, connect the chassis to the local OA&M interface by way of the 37 pin D-Sub connector on the rear panel of the Hub Shelf (see section 2.3: System Alarms).

Turn on the chassis power. Powering up the chassis will “light up” the fiber allowing those installing the Remote Transceivers to identify the transmit and receive cables using an IR sensitive card (see Recommended Tools) to see which fiber is emitting light. The fiber emitting light at the Remote Transceiver end is the transmit path and is connected to the OPTICAL IN connector on the Remote Transceiver (after proper cleaning; see section 2.2.2).

If the transmit RF signal from the BTS or repeater is to be routed to all the plug-ins in both sides of the Hub Shelf, connect the external 1:2 RF splitter supplied with the Hub Shelf to both RF IN ports on the rear panel. If the receive RF signals from all of the plug-ins in both halves of the Hub Shelf are to be routed to a single receive port on the BTS or repeater, connect the other 2:1 RF combiner to both of the RF OUT ports on the rear panel. If one of the RF OUT ports is to be connected to the BTS or repeater receive diversity port, do not connect the RF combiner.

Connect the RF OUT to the BTS or repeater receive port(s).

Before connecting the RF transmit cables from the BTS or repeater to the RF IN of the Hub Shelf, verify that the BTS or repeater RF output power levels are consistent with the desired output power at the Remote Power Supply and will not overdrive or damage the OfficeCell Plug-Ins. Connect the BTS or repeater RF transmit cables to the Hub Shelf.

2.7 Installing the Remote Transceivers

Each Remote Transceiver is mounted above the false ceiling against the wall with the connectors pointing down for easy access. In an area with no false ceiling, it can be mounted in the room near the ceiling with the connectors pointing up. This permits a more aesthetic routing of the cables in the wall-ceiling corner. The

! The minimum bend radius of the fiber is 2 inches (5 cm). Be careful not to kink the fiber.

REMOTE TRANSCEIVER is connected to the Hub Shelf with a singlemode fiberoptic cable with a maximum optical loss of 4 dB, including connectors and patch panels.

To mount the Remote Transceiver, first install the mounting bracket. Two mounting brackets are available. One is smaller and accommodates a single Remote Transceiver. The other, larger bracket accommodates one Remote Transceiver and one Remote Power Supply. The bracket is attached to a wall or bulkhead using #6 panhead or M3.5 screws. The Remote Transceiver (and Power Supply, if applicable) are mounted on the bracket by inserting the rear panel studs into the keyhole slots in the bracket. Each Unit is secured to the bracket by threading the captive thumbscrew (located at the connector end of the unit) into the threaded hole in the tab on the bracket. See the figures below for more detail.

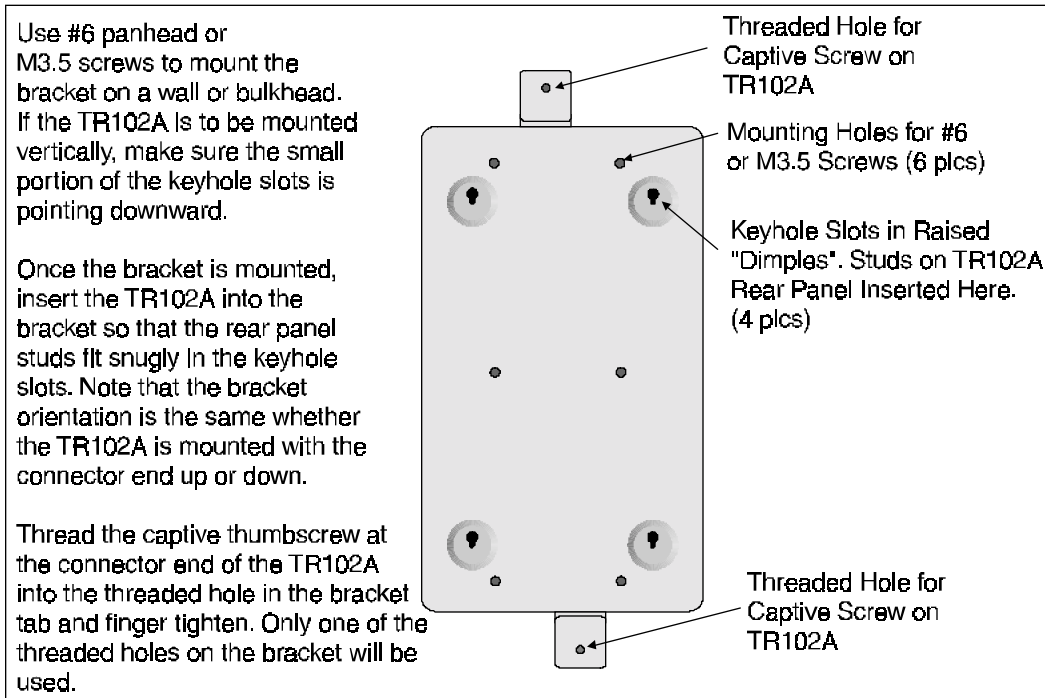

Figure 3. Mounting the Remote Transceiver: Mounting Bracket.

The Remote Transceiver takes +15 to +24 VDC power through a field-installable Molex connector. If the Remote Power Supply is being used, the DC connection is provided by simply plugging in the DC cable from the REMOTE POWER SUPPLY to the REMOTE TRANSCEIVER. The REMOTE POWER SUPPLY should be powered through a shielded AC power cable installed according to local building codes.

For DC versions, the terminals can take wires 18 AWG to 14 AWG. The choice will depend on the voltage used and the distance from the power supply (see Specification, Electrical).

Next, install the indoor coverage antenna according to the manufacturer's instructions. Connect the antenna to the Remote Transceiver RF SMA connector using a flexible RF cable with VSWR < 1.5 : 1 at the frequencies in use.

Any antenna connected to this device must result in an ERP < 1.5W(800 and 900MHz) or < 3.0W (1800MHz and 1900MHz)!

! RF SMA connectors should be tightened with a torque wrench set to 8 in-lbs. Do not overtighten!

Connect the optical cable. The fiber for the transmit (downlink) path connects to the OPTICAL IN connector. The fiber for the receive (uplink) path connects to the OPTICAL OUT connector (Green with laser DANGER



WARNING: Do not look directly into the end of the fiberoptic connector. Laser light is invisible and can cause eye damage.

label). The fibers should be labelled accordingly during installation of the fiberoptic cables. If not, they can be identified by turning the Hub Shelf power on with the plug-ins and fiberoptic cables installed. Then, use an IR sensitive card (see Recommended Tools) to detect the light emitted from the transmit fiber. Point the optical connector on each fiber at the card to see which fiber is emitting light (you see a glowing spot on the card). This is the fiber for the transmit path. The other is for the receive path.

Knowing the desired output power level from each Remote Transceiver as determined by the network design, the Output RF Power can be preset before the system is powered up. Given the rated maximum power from the Remote Transceiver, the antenna gain and the loss in the RF cable, the output RF power is maximum when the Output Power adjustment is set at 0. The static output power can be reduced by turning the adjustment. The adjustment is indented and each indent changes the output power by 2 dB.

Once all connections have been made, turn on the AC power (or DC power, depending on the option used) to Hub Shelf and Remote Transceivers. Before connecting the transmit RF input from the source, check that the level is that needed for optimum signal to noise and distortion as determined in the network design (see Table 1 above). Connect the RF cables to the Hub Shelf.

! To prevent damage to the Hub Shelf plug-ins, do not exceed the maximum ratings for RF input to the Hub Shelf !

3 Monitoring and Troubleshooting

3.1 *Field Support Numbers*

The tips given below should help pinpoint most link problems. Often, problems are a result of a poor optical interface which is easily fixed by properly seating a connector or cleaning the connector. There are no user serviceable parts in the OFFICECELL. Faulty units must be returned to Repeater Technologies Inc. for repair or replacement. For technical support call 800-938-1901 in the U. S. or 408-747-1946.

3.2 Troubleshooting Tips

Alarms	Probable Cause	Action*
Node Function	<ol style="list-style-type: none"> 1. Remote Transceiver Downlink Tx amplifier chain failure 2. Pilot tone oscillator malfunction 3. Pilot tone detector malfunction 	<ol style="list-style-type: none"> 1. If Remote Transceiver Rcvd Opt Pwr LED is OFF, this indicates downlink amplifier chain failure: replace Remote Transceiver. 2. Repair/replace failed Plug-In 3. Repair/replace failed Plug-In
<ol style="list-style-type: none"> 1. Node Function 2. Received Opt Pwr Low (Remote Transceiver) 	<ol style="list-style-type: none"> 1. Problem in downlink fiber path: optical loss too high: fiber run is too long, connector not seated properly, damaged or in need of cleaning, damaged splice 2. Remote Transceiver photodiode failure 	<ol style="list-style-type: none"> 1. Check Rcvd Optical Power LED at Remote Transceiver. If active (Yellow), disconnect downlink fiber and check optical output with light sensitive card. If no light detected, inspect fiber path, esp. any connector recently disconnected. Inspect for proper seating. Clean connectors. If necessary, disconnect fiber from OFFICECELL and check fiber path with OTDR to locate problem. 2. If fiber is OK, indicates Remote Transceiver photodiode failure: replace Remote Transceiver.
<ol style="list-style-type: none"> 1. Node Function 2. Received Opt Pwr Low (Plug-In) 	<ol style="list-style-type: none"> 1. Remote Transceiver laser failure 2. Problem in uplink fiber path: optical loss too high: fiber run is too long, connector not seated properly, damaged or in need of cleaning, damaged splice 3. Plug-In photodiode failure 	<ol style="list-style-type: none"> 1. Check Laser Alarm in Remote Transceiver. If active (Red), replace Remote Power Supply. 2. If not, inspect fiber path, esp. any connector recently disconnected. Inspect for proper seating. Clean connectors. If necessary, disconnect fiber from OFFICECELL and check fiber path with OTDR to locate problem. 3. Replace Plug-In

1. Node Function 2. Received Opt Pwr Low 3. Laser Pwr Low (both Hub Shelf Plug-In and Remote Transceiver)	Failing or failed Plug-In laser	Replace Plug-In
Laser Pwr Low (Hub Shelf Plug-In)	Failing laser	Replace unit Hub Shelf Plug-In
1. Laser Pwr Low (either in Hub Shelf Plug-In or Remote Transceiver) 2. Received Opt Pwr Low (opposite end)	Failing laser	Repair/replace unit (Hub Shelf Plug-In or Remote Transceiver)
Received Opt Pwr Low (Hub Shelf Plug-In)	<ol style="list-style-type: none"> 1. Failed/failing laser in Remote Transceiver 2. Optical loss too high, link may not be operating within specifications. Fiber path may be too long. Problem in fiber path: connector not seated properly, damaged or in need of cleaning, damaged splice 	<ol style="list-style-type: none"> 1. Inspect Remote Transceiver for Laser Alarm LED on (Red). If so, replace Remote Transceiver 2. Inspect fiber path, esp. any connector recently disconnected. Inspect for proper seating. Clean connectors. If necessary, disconnect fiber from system and check fiber path with OTDR to locate problem.
Hub Shelf: Main Power Alarm	Main Power Supply Failure (voltage dropped more than 1 V from +15V)	Replace Main Power Supply
Hub Shelf: Backup Power Supply Alarm	Backup Power Supply Failure (voltage dropped more than 1 V from +15V)	Replace Backup Power Supply
Battery Alarm	<ol style="list-style-type: none"> 1. During battery only operation this would be normal after unit has been on for 10 to 20 minutes. Should go off after main power is restored and battery charges up. 2. If main and/or backup power supplies are OK, this indicates battery or recharging circuit failure 	<ol style="list-style-type: none"> 1. No Problem 2. Replace Chassis

* All repairs of OFFICECELL components must be performed by the factory