

INSTRUCTION MANUAL

1/2 HP

GARAGE DOOR OPENER

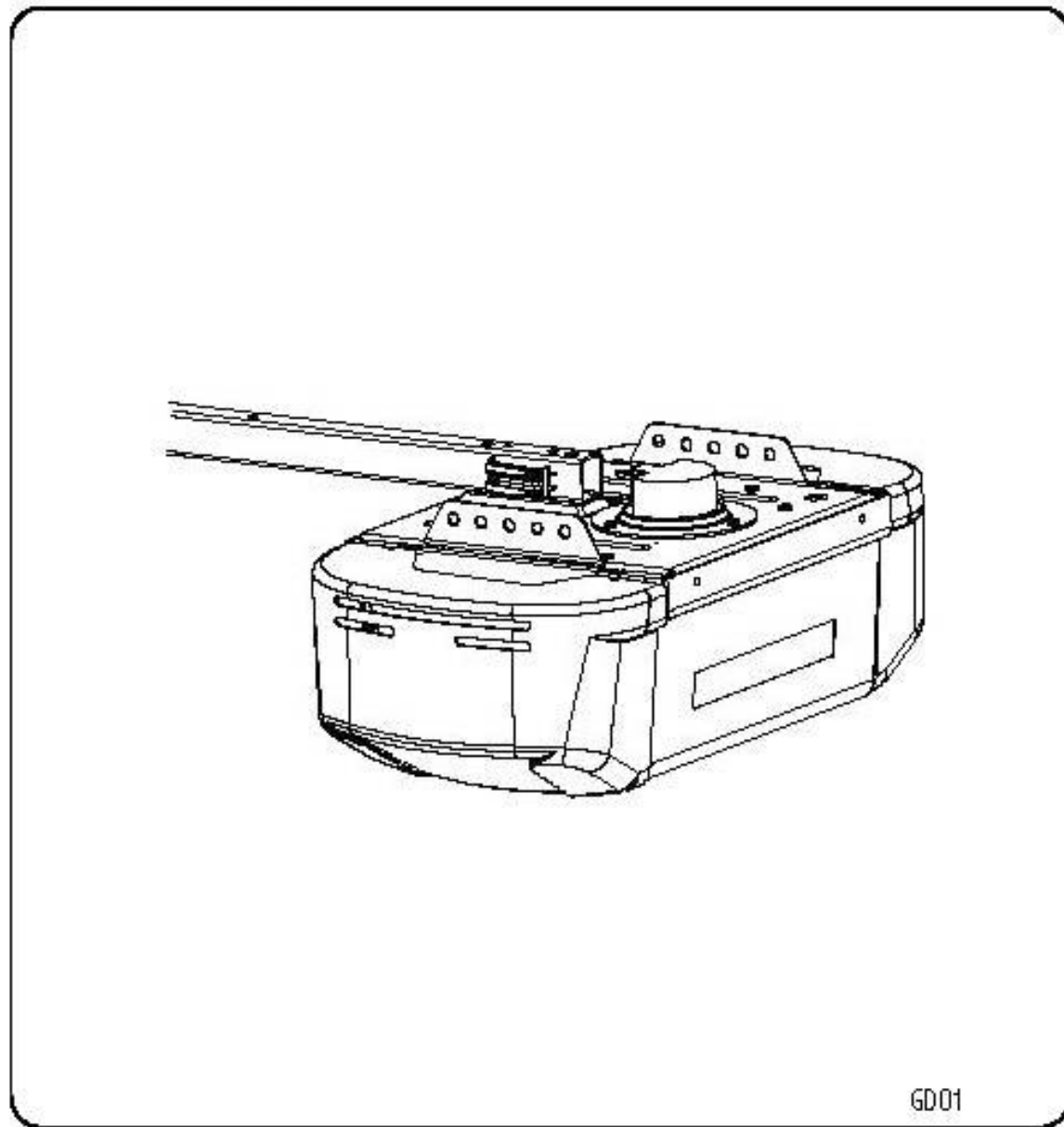

PLEASE KEEP THIS INSTRUCTION MANUAL FOR FUTURE REFERENCE!!

TABLE OF CONTENTS

INTRODUCTION	2-7	Adjustment	28-30
Safety symbol and signal word review	2	Adjust the travel limits	28
Preparing your garage door	3	Adjust the force	29
Tools needed	3	Test the safety reversal system	30
Planning	4-5	Test the safety reversing sensor	30
Carton inventory	6	Operation	31-34
Hardware inventory	7	Operation safety instructions	31
Assembly	8-11	Using your garage door opener	31
Assembly the rail and install trolley	8	Using the Wall-mounted Door control	32
Fasten rail to motor unit and install idler pulley	9	To open the door manually	32
Install chain/cable and attach sprocket cover	10	Care of your garage door opener	33
Tighten the chain	11	TROUBLESHOOTING/Having a problem	34-35
Installation	11-27	Programming	36-37
Installation safety instructions	11	To add a hand-held remote control	36
Determine the header bracket location	12-13	To erase all codes	36
Install the header bracket	14	3-Function Remotes	36
Attach the rail to the header bracket	15	To add or change a Keyless Entry PIN	37
Position the opener	16		
Hang the opener	17		
Install the door control	18		
Install the lights and lens	19		
Attach the emergency release rope and handle	19		
Electrical requirements	20		
Install the safety reversing sensor	21-23		
Fasten the door bracket	24-25		
Connect the door arm to the trolley	26-27		

INTRODUCTION

Safety Symbol and Signal Word Review

This garage door opener has been designed and tested to offer safe service provided it is installed, operated, maintained and tested in strict accordance with the instructions and warnings contained in this manual.

When you see these Safety Symbols and Signal Words on the following pages, they will alert you to the possibility of Serious injury or death if you do not comply with the warnings that accompany them. The hazard may come from something mechanical or from electric shock. Read the warnings carefully.

When you see this Signal Word on the following pages, it will alert you to the possibility of damage to your garage door and/or the garage door opener if you do not comply with the cautionary statements that accompany it. Read them carefully.

PREPARING YOUR GARAGE DOOR

▲ WARNING

To prevent possible **SERIOUS INJURY OR DEATH**:

- ALWAYS call a trained door systems technician if garage door binds, sticks, or is out of balance. An unbalanced garage door may not reverse when required.
- NEVER try to loosen, move or adjust garage door, door springs, cables, pulleys, brackets or their hardware, all of which are under **EXTREME** tension.
- Disable ALL locks and remove ALL ropes connected to garage door **BEFORE** installing and operating garage door opener to avoid entanglement.

Before you begin:

- Disable locks.
- Remove any ropes connected to garage door.
- Complete the following test to make sure your garage door is balanced and is not sticking or binding:
 1. Lift the door about halfway as shown. Release the door. If balanced, it should stay in place supported entirely by its springs.
 2. Raise and lower the door to see if there is any binding or sticking.

If your door binds, sticks, or is out of balance, call a trained door systems technician.

▲ CAUTION

To prevent damage to garage door and opener:

- ALWAYS disable locks before installing and operation the opener.
- ONLY operate garage door opener at 120V, 60Hz to avoid malfunction and damage.



Sectional Door

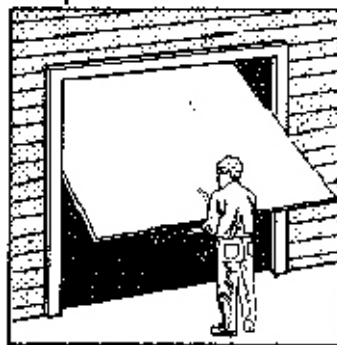

One-Piece Door

TOOLS NEEDED

During assembly, installation and adjustment of the opener, instructions will call for hand tools as illustrated below.

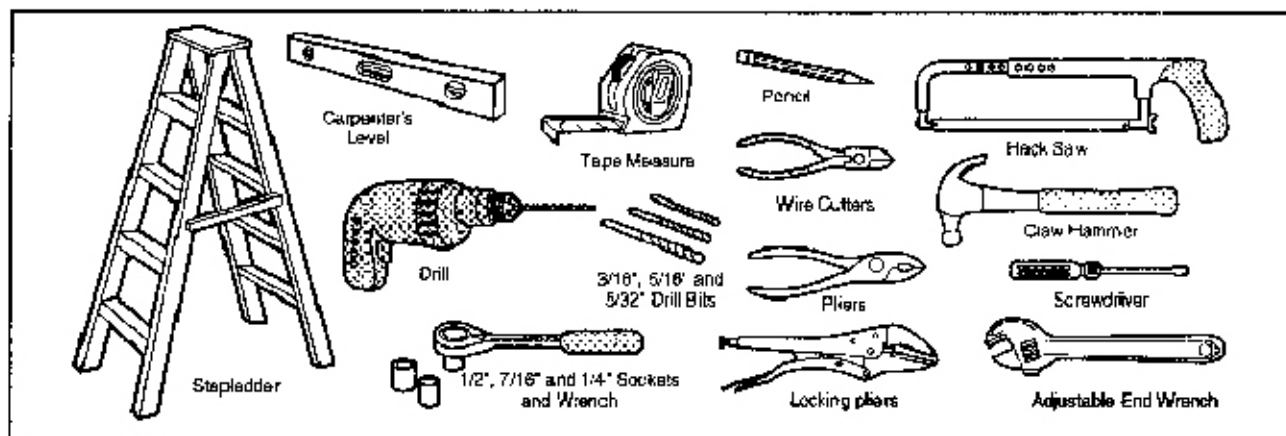

PLANNING

Identify the type and height of your garage door. Survey your garage area to see if any of the conditions below apply to your installation. Additional materials may be required. You may find it helpful to refer back to this page and the accompanying illustrations as you proceed with the installation of your opener.

Depending on your requirements, there are several installation steps which may call for materials or hardware not included in the carton.

- Installation Step 1 – Lock at the wall or ceiling above the garage door. The header bracket must be securely fastened to structural supports.
- Installation Step 5 – Do you have a finished ceiling in your garage? If so, a support bracket and additional fastening hardware may be required.
- Installation Step 10 – Depending upon garage construction, extension brackets or wood blocks may be needed to install sensors.
- Installation Step 10 – Alternate floor mounting of the safety reversing sensor will require hardware not provided.
- Do you have an access door in addition to the garage door? If not, Key release is required. See Accessories page.
- Look at the garage door where it meets the floor. Any gap between the floor and the bottom of the door must not exceed 1/4". Otherwise, the safety reversal system may not work properly. See Adjustment Step 3. Floor or door should be required.

SECTIONAL DOOR INSTALLATIONS

- Do you have a steel, aluminum, fiberglass or glass panel door? If so, horizontal and vertical reinforcement is required (Installation Step 11).
- The opener should be installed above the center of bearing plate in the way of the header bracket, it may be installed within 4 feet to the left or right of the door center. See Installation Steps 1 and 11.
- **If your door is more than 7 feet high, see rail extension kits listed on Accessories page.**

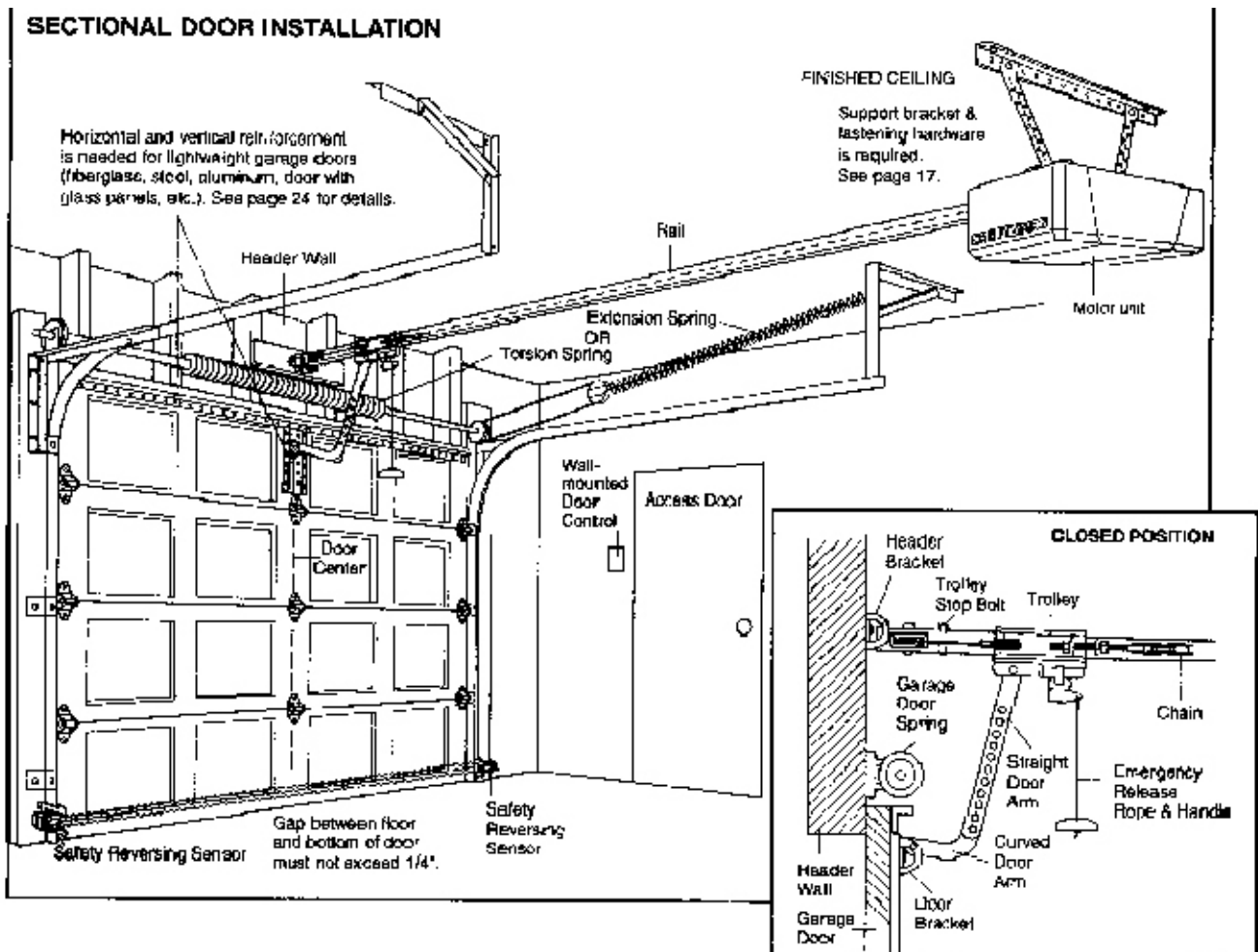

PLANNING

⚠ WARNING

Without a properly working safety reversal system, persons (particularly small children) could be **SERIOUSLY INJURED** or **KILLED** by a closing garage door.

- The gap between the bottom of the garage door and the floor **MUST NOT** exceed 1/4". Otherwise, the safety reversal system may not work properly.
- The floor or the garage door **MUST** be repaired to eliminate the gap.

ONE-PIECE DOOR INSTALLATIONS

- Generally, a one-piece door does not require reinforcement. If your door is lightweight, refer to the information relating to sectional doors in Installation Step 11.
- Depending on your door's construction, you may need additional mounting hardware for the door bracket (Step 11).

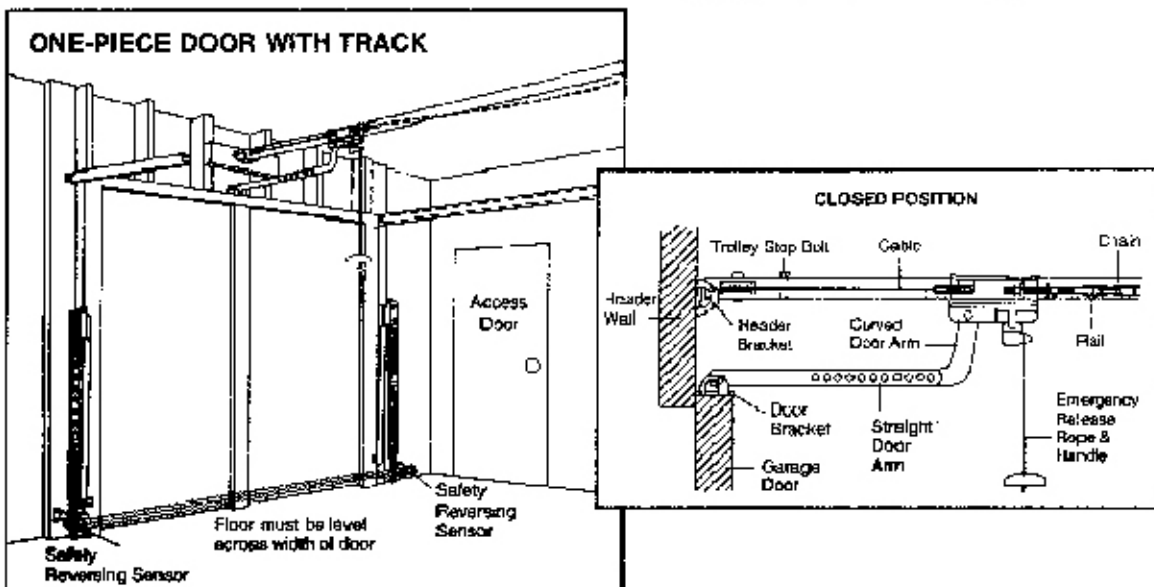
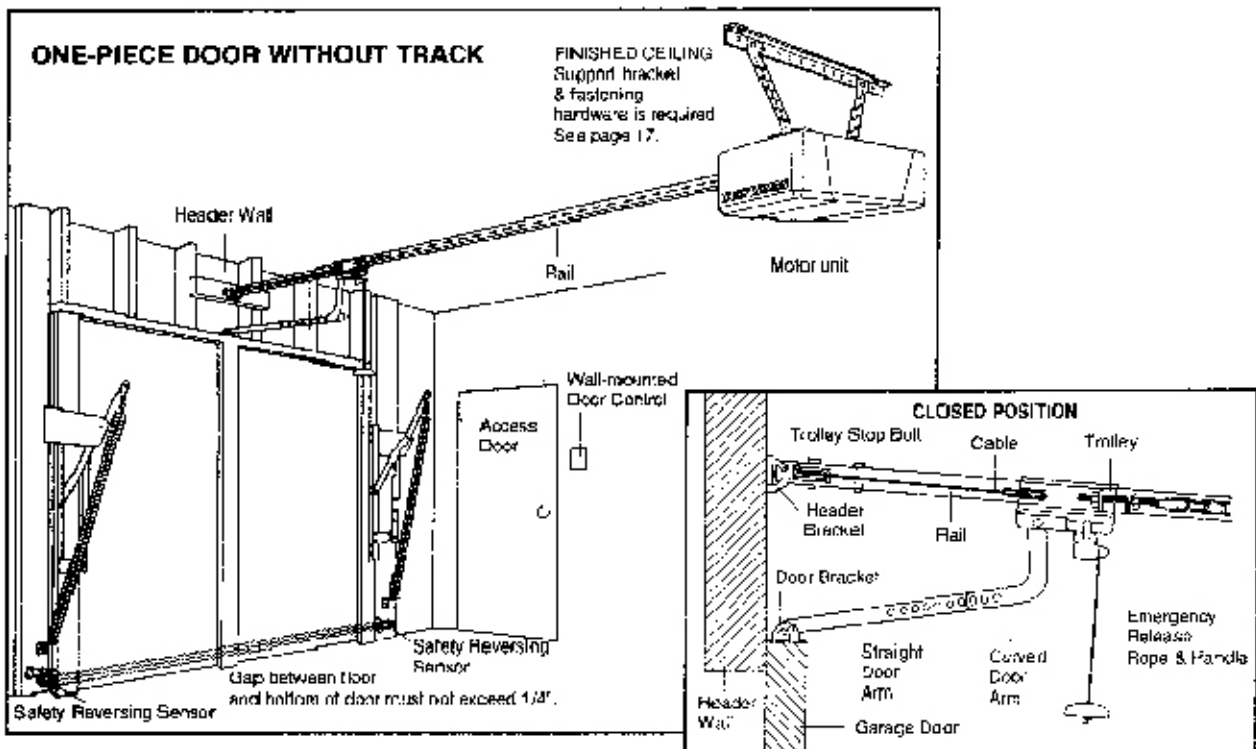

CARTON CONTENTS

Your garage door opener is packaged in one cartons which contains the motor unit and the parts illustrated below. Note that accessories will depend on the model purchased. If anything is missing, carefully check the packing material. Parts may be stuck in the foam. Hardware for assembly and installation is shown on the next page. Save the carton and packing material until installation and adjustment is complete.

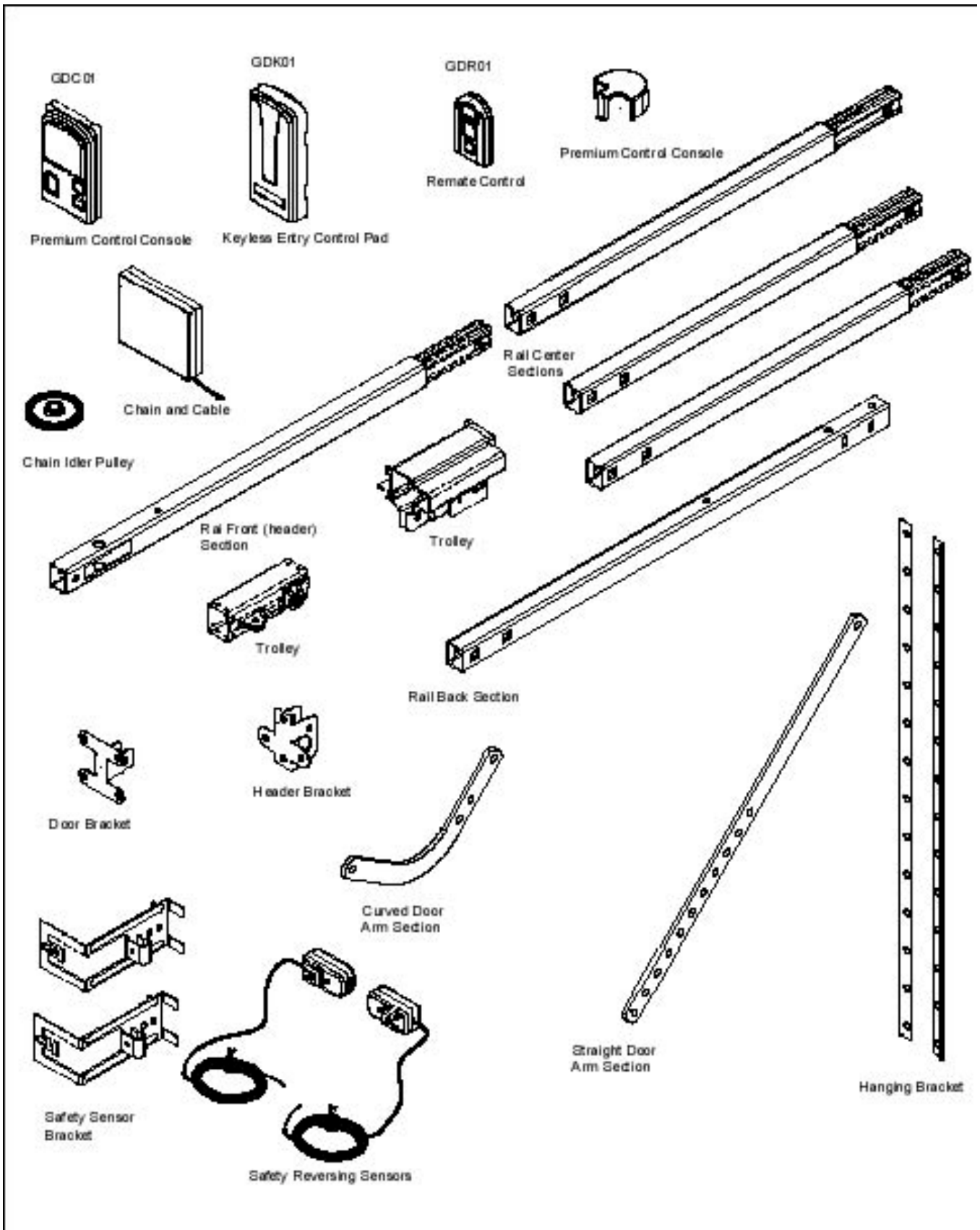

HARDWARE INVENTORY

Separate all hardware and group as shown below for the assembly and installation procedures.

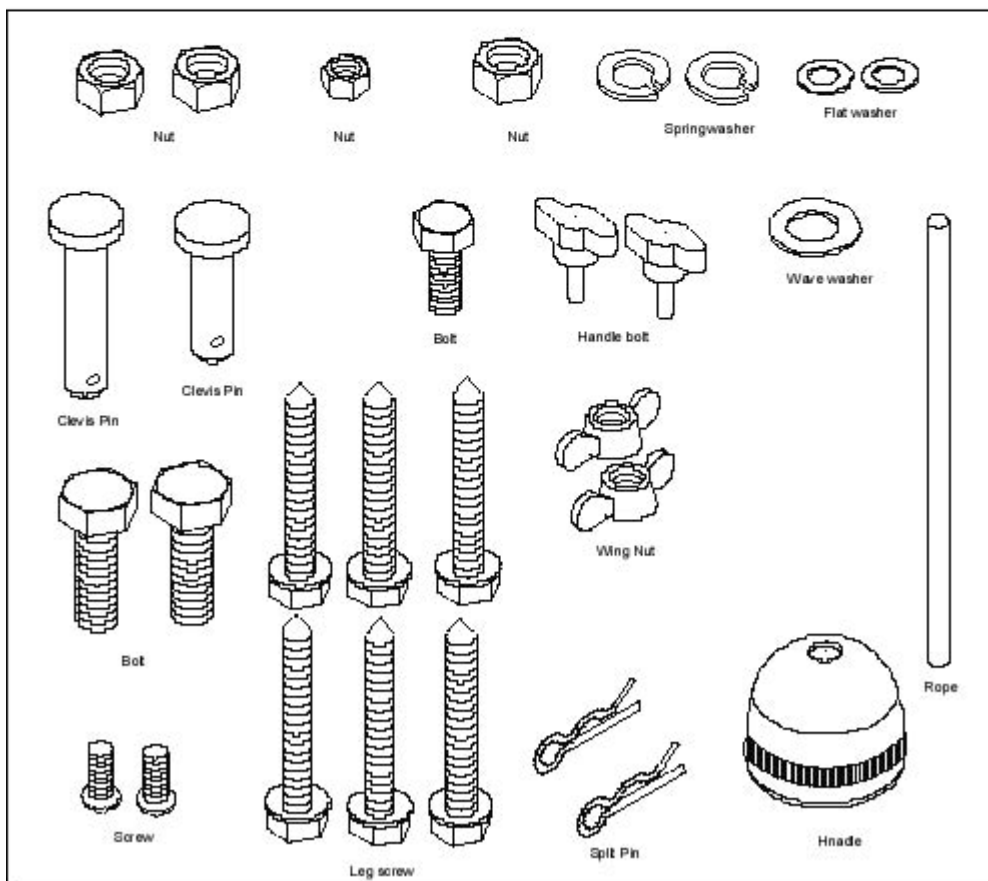
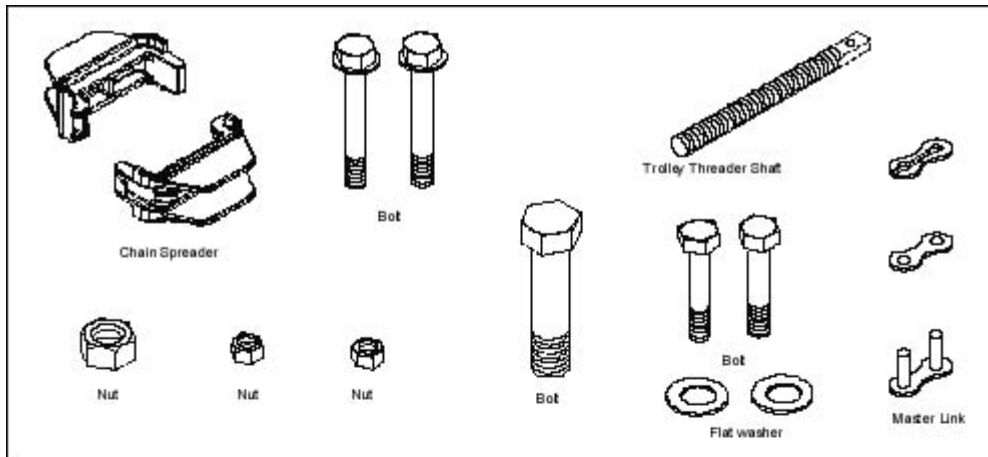

ASSEMBLY

ASSEMBLY STEP 1

Assemble the Rail & Install the Trolley

To avoid installation difficulties, do not run the garage door opener until instructed to do so.

The front rail has a cut out “ window ” at the door and (see illustration). The hole above this window is larger on the top of the rail than on the bottom. A smaller hole 12.5mm away is close to the rail edge. A 5-piece rail uses one front rail, three middle rails and one back rail.

1. Remove the straight door arm and clevis pin packaged inside the front rail and set aside for Installation Step 12.
2. Align the rail sections on a flat surface exactly as shown and slide the tapered ends into the larger ones. Tabs along the side will lock into place.
3. Place the motor unit on packing material to protect the cover, and rest the back end of the rail on top. For convenience, put a support under the front end of the rail.
4. As a temporary trolley stop, clamp a locking pliers onto the rail, 12” from the center of the idler pulley hole, as shown.
5. Check to be sure there are 4 black plastic wear pads inside the inner trolley. If they became loose during shipping, check all packing material. Snap them back into position as shown.
6. Connect the inner and outer trolleys as shown.
7. Slide the trolley assembly along the rail from the back end to the locked pliers.

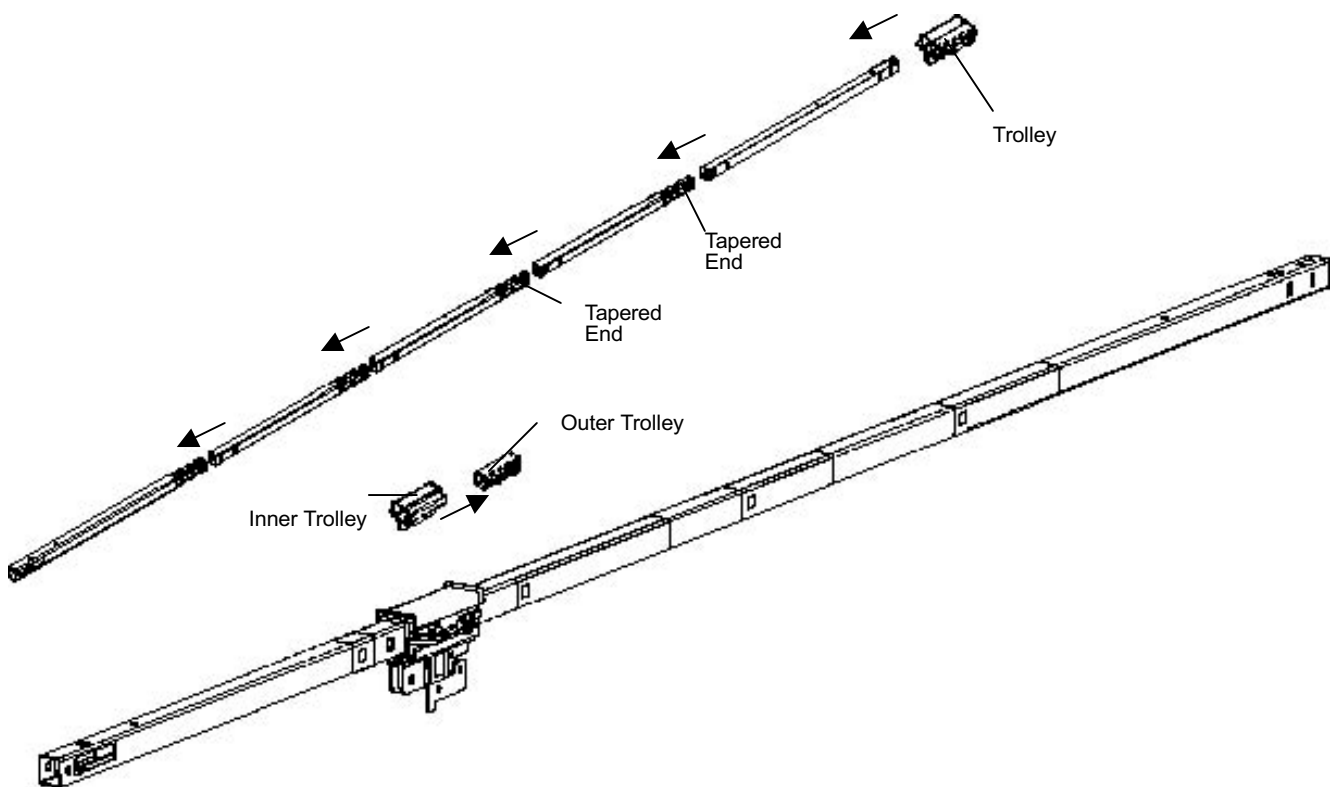

ASSEMBLY

ASSEMBLY STEP 2

Install the Idler Pulley

- Lay the chain/cable beside the rail, as shown. Grasp the end with the cable loop and pass approximately 12" of cable through the window. Allow it to hang until Assembly Step 5.
- Remove the tape from the idler pulley. The inside center should be pre-greased. If dry, regrease to ensure proper operation.
- Place the idler pulley into the window as shown.
- Insert the idler bolt from the top through the rail and pulley. Tighten with nut underneath the rail.
- Rotate the pulley to be sure it spins freely.
- Insert a M6x1.0-45 bolt into the trolley stop hole in the front of the rail as shown. Tighten securely with a nut chuck.

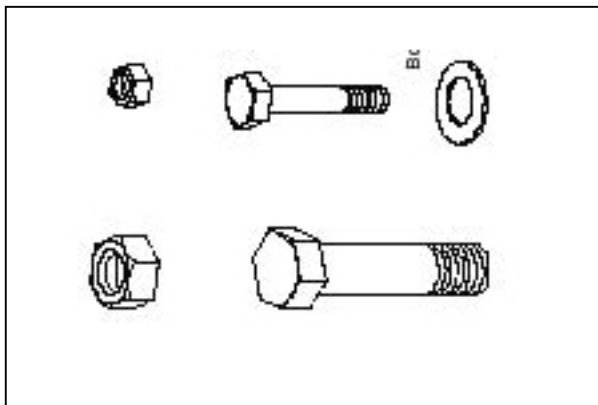

Hardware shown

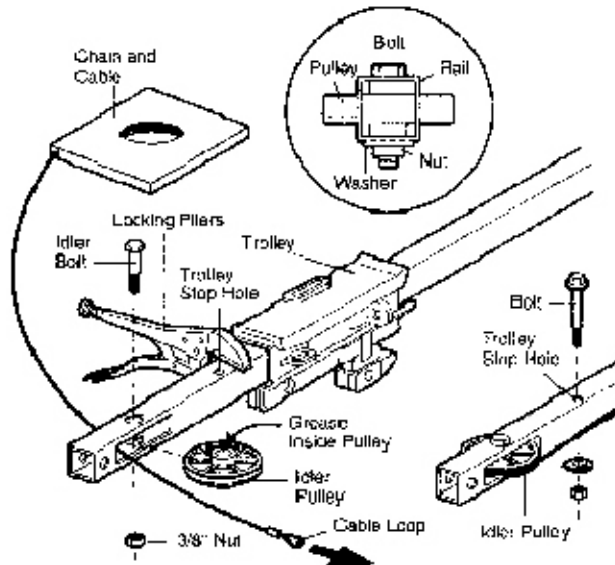

ASSEMBLY STEP 3

Fasten the Rail to the Motor Unit



To avoid serious damage to garage door opener, use only those screws mounted in the top of the opener.

- Insert two M8x1.25-45 bolts from the top through the back rail and the motor unit as shown. Tighten the bolts.
- Attach the chain spreaders to the back rail by snapping them into place.
- Insert a M6x1.0-45 bolt into the back end of the rail as shown. Tighten securely with a nut chuck.

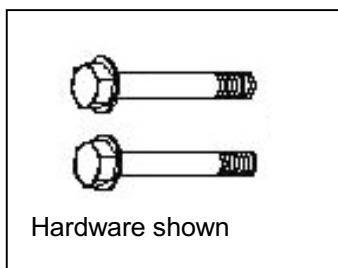

Hardware shown

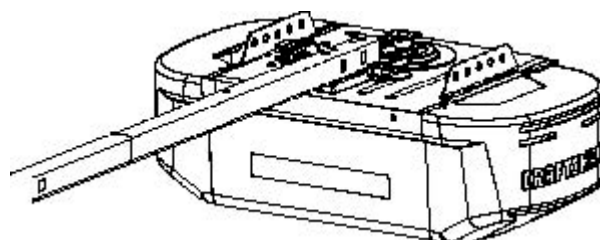

ASSEMBLY

ASSEMBLY STEP 4

Warning!!

To avoid possible serious injury to fingers from moving garage door opener:

- ALWAYS keep hand clear of sprocket while operating opener.
- Securely attach sprocket cover BEFORE operating.

Install the Chain/Cable and Attach the Sprocket Cover

1. Pull the cable around the idler pulley and toward the trolley.

Note: The chain have to through the out trolley.

2. Connect the cable loop to the retaining slot on the trolley, as shown:

- From below, push pin of master link bar up through trolley threaded shaft.
- Slide clip-on spring over cap and onto pin notches until both pins are securely locked in place.
- Insert the a M6x1.0-20 bolt through cable loop and trolley slotted hole. Tighten securely with a nut.

3. With the trolley against the pliers, dispense the remainder of the cable/chain along the rail toward the motor unit and around the sprocket. The sprocket teeth must engage the chain.

4. Check to make sure the chain is not twisted, then remaining master link.

5. Thread the inner nut and wave washer onto the trolley shaft.

6. Insert the trolley threaded shaft through the hole in the trolley. Be sure the chain is not twisted.

7. Loosely thread the outer nut onto the trolley shaft.

8. Remove the locking pliers.

9. Align the tabs on the sprocket cover with the slots in the mounting plate. Squeeze cover and insert tabs in slots.

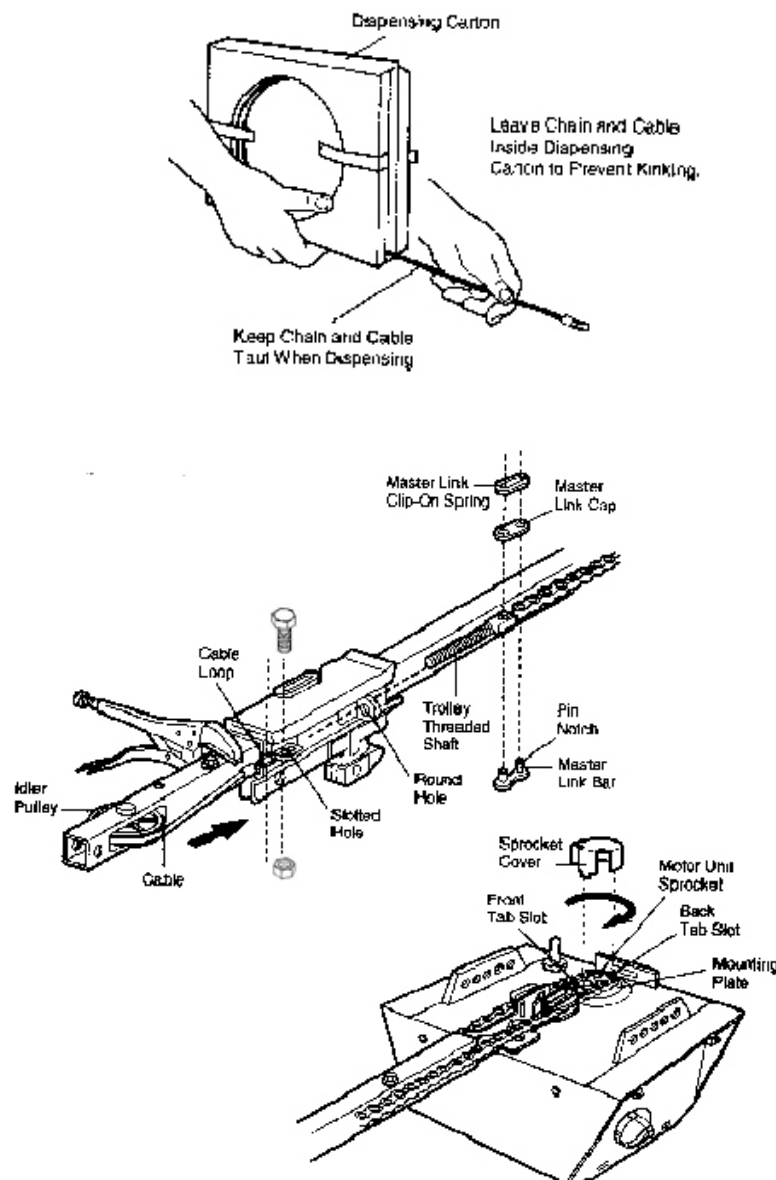

ASSEMBLY

ASSEMBLY STEP 5

Tighten the Chain

- Spin the inner nut and wave washer down the threaded shaft, away from the trolley.
- To tighten the chain, turn outer nut in the direction shown (Fig. 1).
- When the chain is approximately 1/2" above the base of the rail at its midpoint, re-tighten the inner nut to secure the adjustment.

Sprocket noise can result if chain is too loose. When installation is complete, you may notice some chain droop with the door closed. This is normal. If the chain returns to the position shown in Fig. 2 when the door is open, do not re-adjust the chain.

NOTE: During future maintenance, ALWAYS pull the emergency release handle to disconnect trolley before adjusting chain.

NOTE: You may notice loosening of chain after Adjustment Step 3 (Test the Safety Reversal System). Check for proper tension and readjust chain if necessary. Then repeat Adjustment Step 3.

You have now finished assembling your garage door opener. Please read the following warnings before proceeding to the installation section:

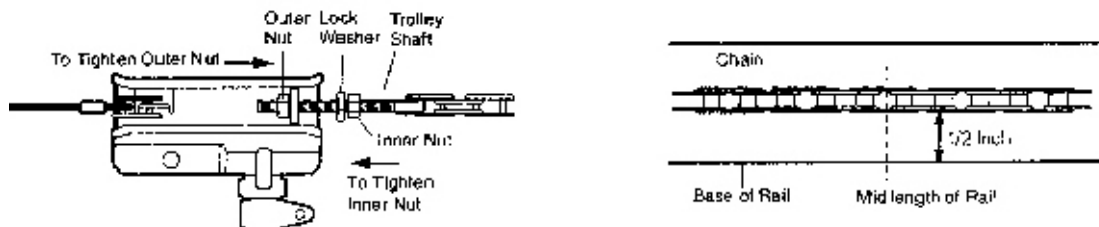

INSTALLATION

IMPORTANT INSTALLATION INSTRUCTIONS

⚠ WARNING

To reduce the risk of severe injury or death:

1. READ AND FOLLOW ALL INSTALLATION WARNINGS AND INSTRUCTIONS.
2. Install garage door opener only on properly balanced and lubricated garage door. An improperly balanced door may not reverse when required and could result in severe injury or death.
3. All repairs to cables, spring assemblies and other hardware MUST be made by a trained door systems technician before installing opener.
4. Disable all locks and remove all ropes connected to garage door before installing opener to avoid entanglement.
5. Install garage door opener 7 feet or more above floor.
6. Mount emergency release handle 6 feet above floor.
7. NEVER connect garage door opener to power source until instructed to do so.
8. NEVER wear watches, rings or loose clothing while installing or servicing opener. They could be caught in garage door or opener mechanisms.
9. Install wall-mounted garage door control:
 - within sight of the garage door
 - out of reach of children at minimum height of 5 feet
 - away from all moving parts of the door.
10. Place entrapment warning label on wall next to garage door control.
11. Place manual release/safety reverse test label in plain view on inside of garage door.
12. Upon completion of installation, test safety reversal system. Door MUST reverse on contact with a one-inch high object (or a 2x4 laid flat) on the floor.

INSTALLATION

INSTALLATION STEP 1

Determine the header Bracket Location

To prevent possible SERIOUS INJURY or DEATH:

- Header bracket Must be RIGIDLY fastened to structural support on header wall or ceiling, otherwise garage door might not reverse when required. Do not install header bracket over drywall.
- Concrete anchors MUST be used if mounting header bracket or 2x4 into masonry.
- NEVER try to loosen, move or adjust garage door, spring, cables, pulleys, brackets, or their hardware, all of which are under EXTREME tension.
- ALWAYS call a trained door systems technician if garage door binds, sticks, or is out of balance. An unbalanced garage door might not reverse when required.

Installation procedures vary according to garage door types. Follow the instructions which apply to your door.

SECTIONAL DOOR AND ONE-PIECE DOOR WITH TRACK

1. Close the door and mark the inside vertical centerline of the garage door.
2. Extend the line onto the header wall above the door.

You can fasten the header bracket within 4 feet of the left or right of the door center only if a way; or you can attach it to the ceiling (see [page 14](#)) when clearance is minimal. (It may be mounted on the wall upside down if necessary, to gain approximately 1/2"). If you need to install the header bracket on a 2x4 (on wall or ceiling), use lag screws (not provided) to securely fasten the 2x4 to structural supports as shown here and on [page 13](#).

3. Open your door to the highest point of travel as shown. Draw an intersecting horizontal line on the header wall 2" above the high point. This height will provide travel clearance for the top edge of the door.

NOTE: Door clearance brackets are available for sectional doors when headroom clearance is less than 2".

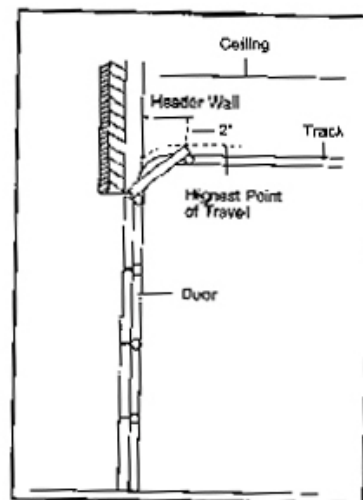
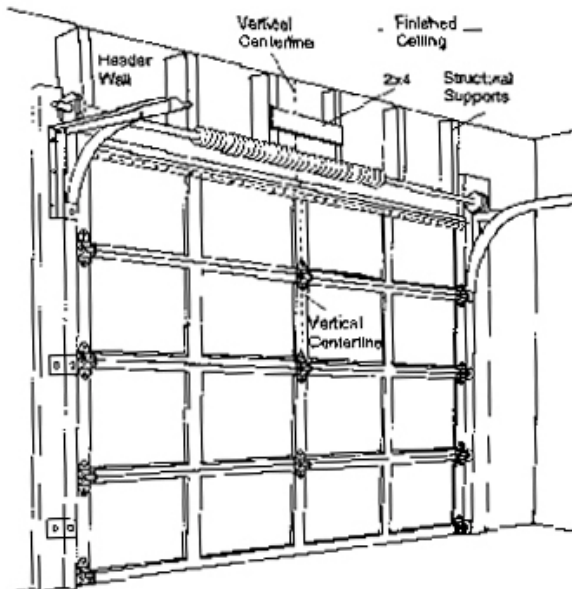

Sectional door with curved track

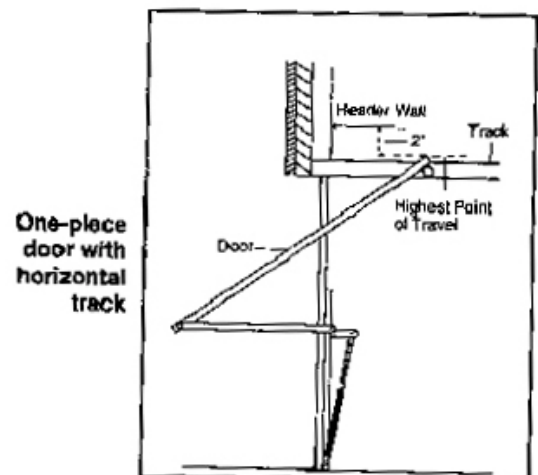

One-piece door with horizontal track

INSTALLATION

ONE-PIECE DOOR WITHOUT TRACK

1. Close the door and mark the inside vertical centerline of your garage door. Extend the line onto the header wall above door, as shown. If headroom clearance is minimal, you can install the header bracket on ceiling. See page 14. If you need to install the header bracket on a 2x4 (on wall or ceiling), use lag screws (not provided) to securely fasten the 2x4 to structural supports as shown.
 2. Open your door to the highest point of travel as shown. Measure the distance from the top of the door to the floor. Subtract the actual height of the door. Add 8" to the remainder. (See Example).
 3. Close the door and draw an intersecting horizontal line on the header wall at the determined height.
- NOTE: If the total number of inches exceeds the height available in you garage, use the maximum height possible, or refer to page 14 ceiling installation.

EXAMPLE

$$92'' - 88'' = 4'' \quad 4'' + 8'' = 12''$$

92"=Distance from top of door (at highest point of travel) to floor

88"=Actual height of door

4"=Remainder

8"=Add

12"=Bracket height on header wall (Measure UP from top of CLOSED door.)

Proceed to Step 2, page 14.

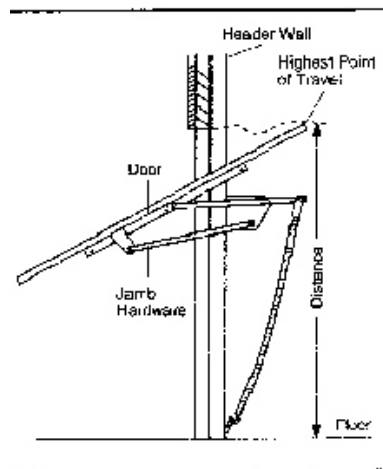
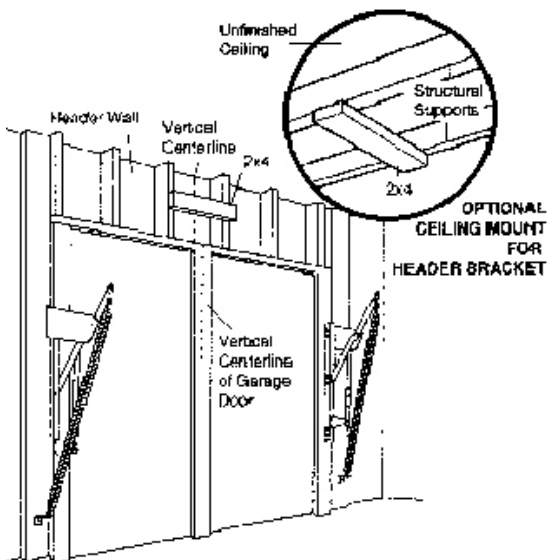

One-piece door without track:
jamb hardware

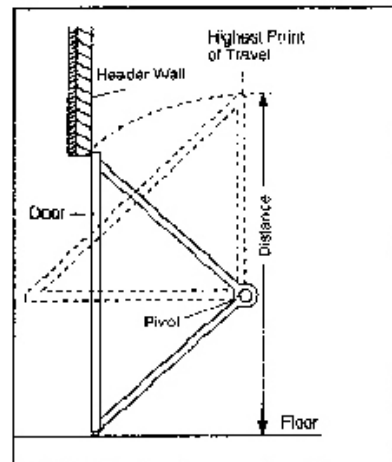

One-piece door without track:
pivot hardware

INSTALLATION

INSTALLATION STEP 2

Install the Header Bracket

You can attach the header bracket either to the wall above the garage door, or to the ceiling. Follow the instructions which will work best for your particular requirements. **Do not install the header bracket over drywall. If installing into masonry, use concrete anchors (not provided).**

WALL HEADER BRACKET INSTALLATION

- Center the bracket on the vertical centerline with the bottom edge of the bracket on the horizontal line as shown (with the arrow pointing toward the ceiling).
- Mark the vertical set of bracket holes. Drill 3/16" pilot holes and fasten the bracket securely to a structural support with the hardware provided.

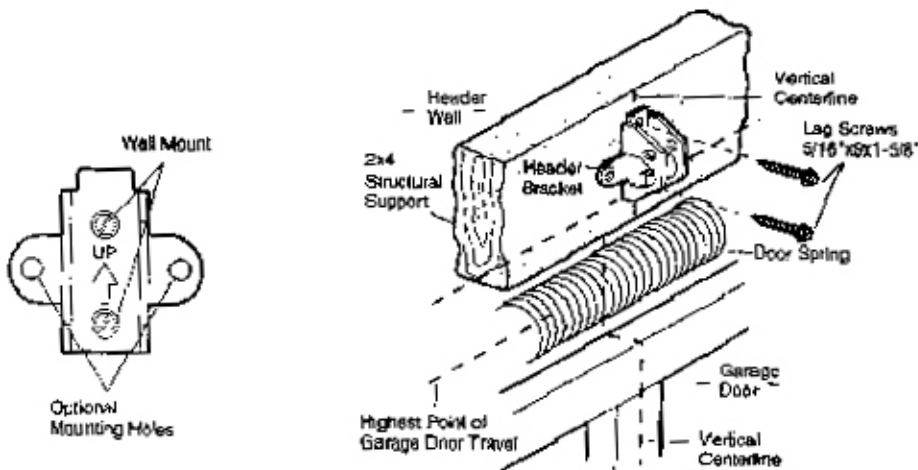

CEILING HEADER BRACKET INSTALLATION

- Extend the vertical centerline onto the ceiling as shown.
- Center the bracket on the vertical mark, no more than 6" from the wall. Make sure the arrow is pointing away from the wall. The bracket can be mounted flush against the ceiling when clearance is minimal.
- Mark the side holes. Drill 3/16" pilot holes and fasten bracket securely to a structural support with the hardware provided.

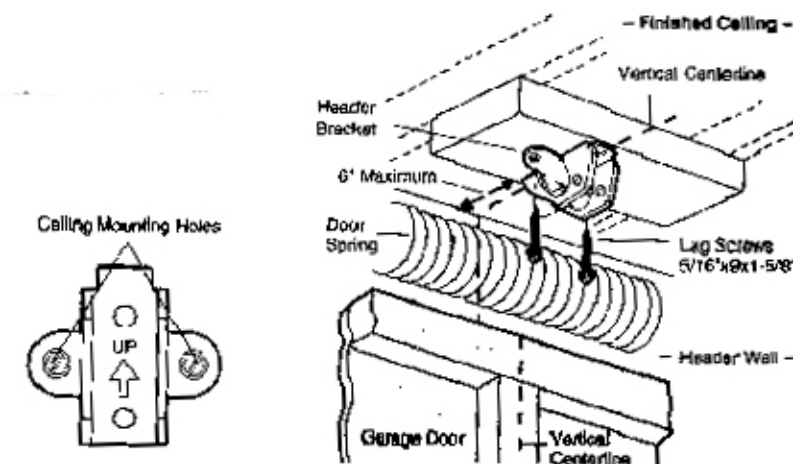

INSTALLATION

INSTALLATION STEP 3

Attach the Rail to the Header Bracket

NOTE: (Optional) you may re-use the old header bracket with the two plastic spacers included in the hardware bag. Place the spacers inside the bracket on each side of the rail, as illustrated.

- Position the opener on the garage floor below the header bracket. Use packing material as a protective base.
NOTE: If the door spring is in the way you'll need help. Have someone hold the opener securely on temporary support to allow the rail to clear the spring.
- Position the front rail end within the header bracket and join with a Ø8-3.5mm clevis pin as shown.
- Insert a split pin to secure.

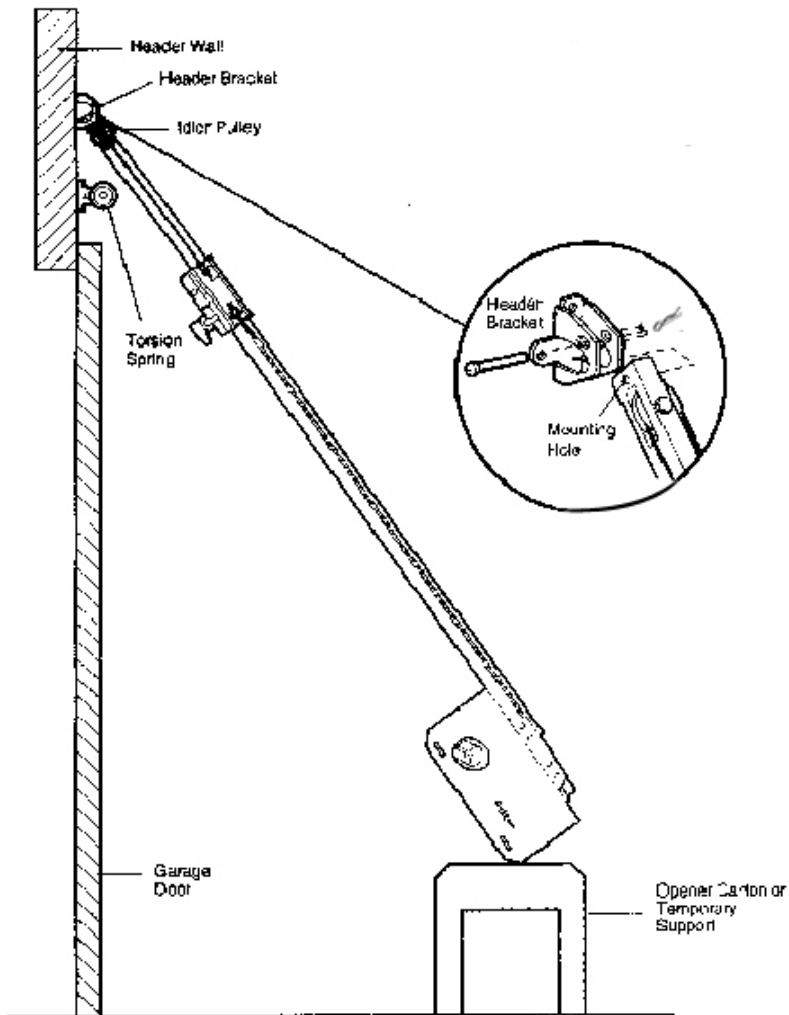

INSTALLATION

INSTALLATIONS STEP 4

Position the Opener

Follow instructions which apply to your door type as illustrated.

CAUTION

To prevent damage to garage door, rest garage door opener rail on 2x4 placed on top section of door.

SECTIONAL DOOR OR ON-PIECE DOOR WITH TRACK

A 2x4 laid flat is convenient for setting an ideal door-to-rail distance.

- Raise the opener onto a stepladder. You will need help at this point if the ladder is not tall enough.
- Open the door all the way and place a 2x4 laid flat on the top section beneath the rail.
- If the top section or panel hits the trolley when you raise the door, pull down on the trolley release arm to disconnect inner and outer sections. Slide the outer trolley toward the motor unit. The trolley can remain disconnected until Installation Step 12.

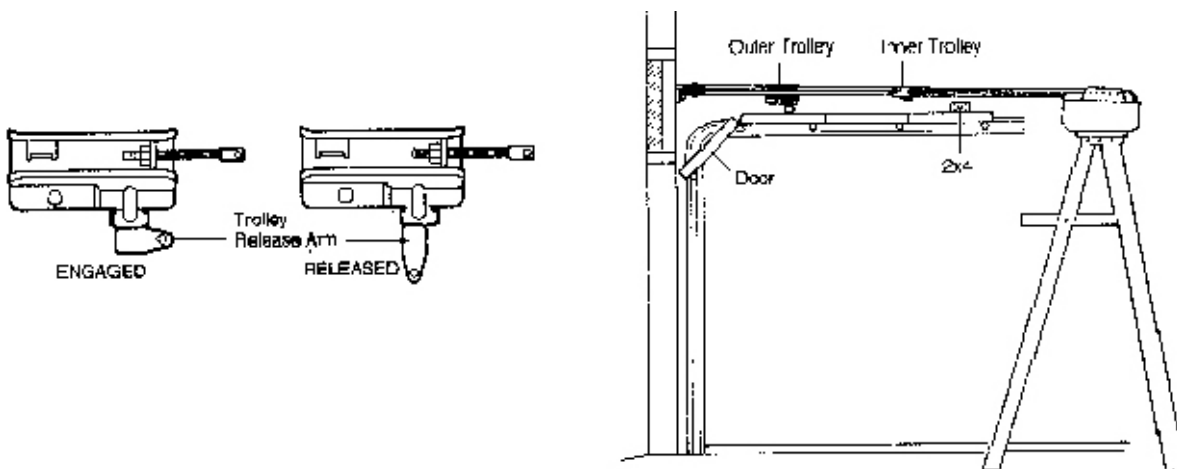

ONE-PIECE DOOR WITHOUT TRACK

- With the door fully open and parallel to the floor, measure the distance from the floor to the top of the door.
- Using a stepladder as a support, raise the top of the opener to this height.
- The top of the door should be level with the top of the motor unit. Do not position the opener more than 2" above this point.

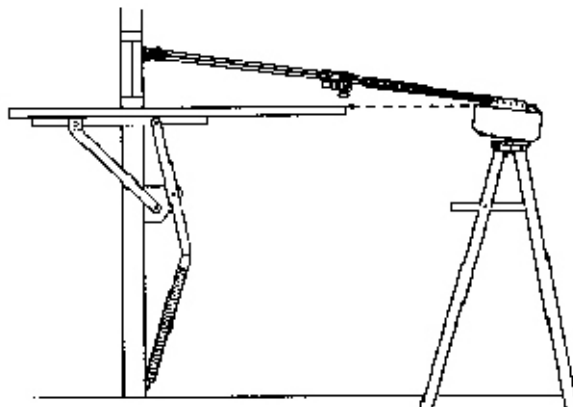

INSTALLATION

INSTALLATION STEP 5

Hang the Opener

WARNING!!!

To avoid possible **SERIOUS UNJURY** from a falling garage door opener, fasten it **SECURELY** to structural supports of the garage. Concrete anchors **MUST** be used if installing any brackets into masonry.

Two representative installations are shown. Yours may be different. Hanging brackets should be angled (Fig. 1) to provide rigid support. On finished ceilings (Fig. 2), attach a sturdy metal bracket to structural supports before installing the opener. This bracket and fastening hardware are not provided. (See Accessories.)

1. Measure the distance from each side of the motor unit to the structural support.
2. Cut both pieces of the hanging bracket to required lengths.
3. Drill 3/16" pilot holes in the structural supports.
4. Attach one end of each bracket to a support with 5/16"-18x1-7/8" lag screws.
5. Fasten the opener to the hanging brackets with 5/16"-18x7/8" hex screws, lock washers and nuts.
6. Chuck to make sure the rail is centered over the door (or in line with the header bracket if the bracket is not centered above the door).
7. Remove the 2x4. Operate the door manually. If the door hits the rail, raise the header bracket.

NOTE: Do NOT connect power to opener at this time.

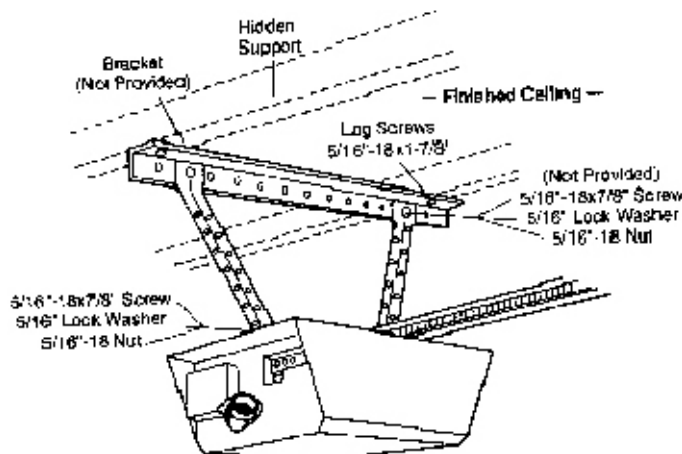
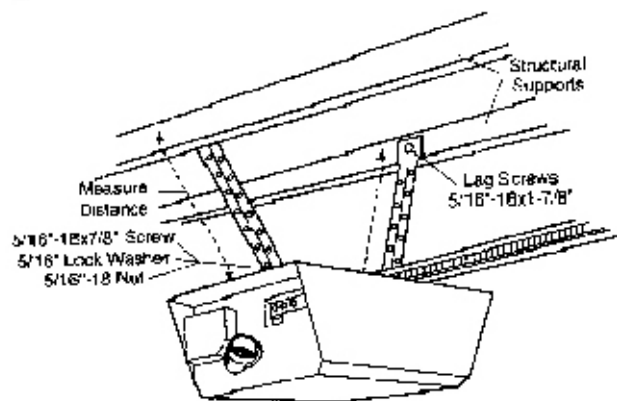

INSTALLATION

INSTALLATION STEP 6

Install the Premium control console and Keyless Entry control pad

WARNING!!

To prevent possible SERIOUS INJURY or Death FROM electrocution:

- Be sure power is not connected BEFORE installing door control.
- Connect ONLY to 24 VOLT low voltage wires.

To prevent possible SERIOUS INJURY or DEATH from a closing garage door:

- Install door control within sight of garage door, out of reach of children at a minimum height of 5 feet, and away from all moving parts of door.
- NEVER permit children to operate or play with door control push buttons or remote control transmitters.
- Activate door ONLY when it can be seen clearly, is properly adjusted, and there are no obstructions to door travel.
- ALWAYS keep garage door in sight until completely closed. NEVER permit anyone to cross path of closing garage door.

Locate door control within sight of door, at a minimum height of 5 feet where small children cannot reach, away from moving parts of door and door hardware. If installing into drywall, drill $3/32"$ two holes and use the anchors provided. For pre-wired installations (as in new home construction), it may be mounted to a single gang box (Fig. 2).

1. Premium control console: Pry off cover along one side with a screwdriver blade (see Fig. 1). Fasten with M4x16-20mm screws (standard installation) or machine screws (into gang box) as follows:
 - Install bottom screw, allowing $1/8"$ to protrude above wall surface.
 - Position bottom of door control on screw head and slide down to secure. Adjust screw for snug fit.
 - Drill and install top screw with care to avoid cracking plastic housing. Do not overtighten.
 - Insert top tabs and snap on cover.
2. (For standard installation only) Run bell wire up wall and across ceiling to motor unit. Use insulated staples to secure wire in several places. Be careful not to pierce wire with a staple, creating a short or open circuit.
3. Connect the bell wire to the terminal screws on the motor unit panel: white to 2(gnd); white/red to 1.
4. Position the antenna wire as shown.
5. Use tacks or staples permanently attach entrapment warning label to wall near Premium control console, and manual release/safety reverse test label in a prominent location on inside of garage door.

Install the Keyless Entry control pad

1. Installing into drywall, drill $3/32"$ two holes as shown. (Fig. 3)
2. Place the Keyless Entry control pad into the top screws.

DO NOT connect power and operate opener at this time. The trolley will travel to the full open position but will not return to the close position until the sensor beam is connected and properly aligned.

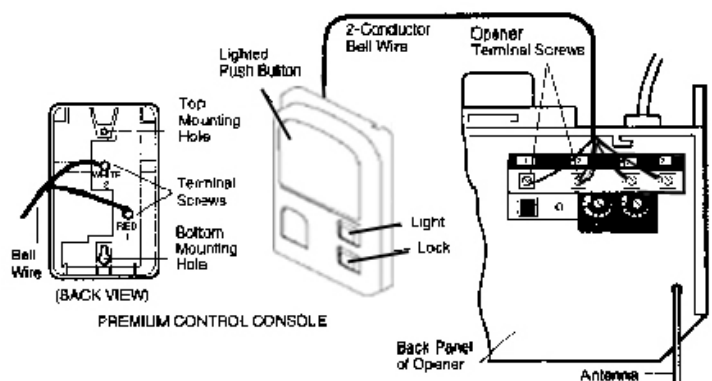
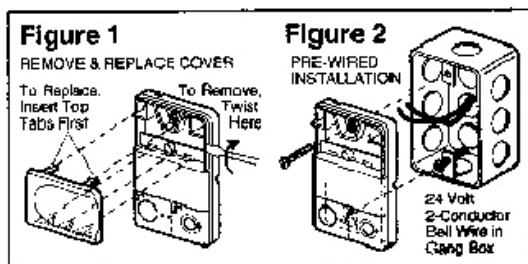

INSTALLATION

INSTALLATIONS STEP 7

Install the Lights and Lenses

- Install a 75 watt maximum light bulb in each socket. The lights will turn ON and remain lit for approximately 4-1/2 minutes when power is connected. Then the lights will turn OFF.
- Apply slight pressure on the sides of each lens and slide the tabs into the slots in the side panels. (See illustration.)
- For convenience, the lenses may be installed after Adjustment Step 4 on page 30.
- To remove, reverse the procedure. Use care to avoid snapping off lens tabs.
- Use standard neck Garage Door Opener bulbs for replacement.

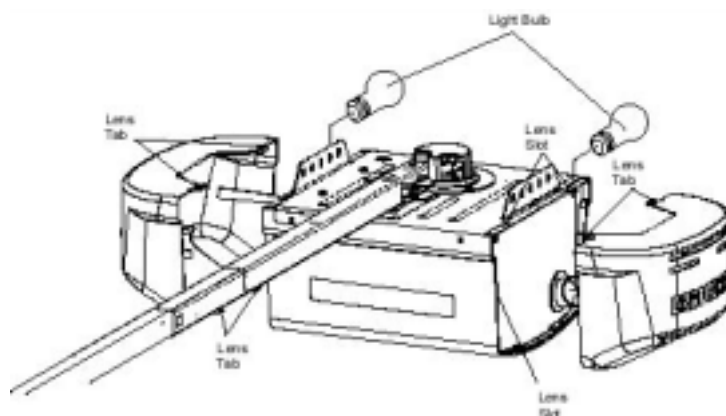

INSTALLATION STEP 8

WARNING!

- To prevent possible SERIOUS INJURY or DEATH from a falling garage door:
 - If possible, use emergency release handle to disengage trolley ONLY when garage door is CLOSED. Weak or broken springs or unbalanced door could result in an open door falling rapidly and/or unexpectedly.
 - NEVER use emergency release handle unless garage doorway is clear of persons and obstructions.
- NEVER use handle to pull door open or closed. If rope knot becomes untied, you could fall.

Attach the Emergency Release Rope and Handle

- Thread one end of the rope through the hole in the top of the red handle so "NOTICE" reads right side up as shown. Secure with an overhand knot at least 1" from the end of the rope to prevent slipping.
- Adjust rope length so the handle is 6 feet above the floor. Secure with an overhand knot.

NOTE: If it is necessary to cut the rope, heat seal the cut end with a match or lighter to prevent unraveling.

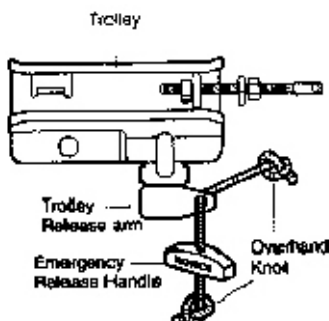

INSTALLATION

INSTALLATIONS STEP 9

Electrical Requirements

WARNING!!

To prevent possible **SERIOUS INJURY** or **DEATH** from electrocution or fire:

- Be sure power is not connected to the opener, and disconnect power to circuit **BEFORE** removing cover to establish permanent wiring connection.
- Garage door installation and wiring **MUST** be in compliance with all local electrical and building codes.
- **NEVER** use an extension cord, 2-wire adapter, or change plug in any way to make it fit outlet. Be sure the opener is grounded.

To avoid installation difficulties, do not run the opener at this time.

To reduce the risk of electric shock, your garage door opener has a grounding type plug with a third grounding pin. This plug will only fit into a grounding type outlet. If the plug does not fit into the outlet you have, contact a qualified electrician to install the proper outlet.

If permanent wiring is required by your local code, refer to the following procedure.

To make a permanent connection through the 7/8" hole in the top of the motor unit:

- Remove the motor unit cover screws and set the cover aside.
- Remove the attached 3-prong cord.
- Connect the black (line) wire to the screw on the brass terminal; the white (neutral) wire to the screw on the silver terminal; and the ground wire to the green ground screw. The opener must be grounded.
- Reinstall the cover.

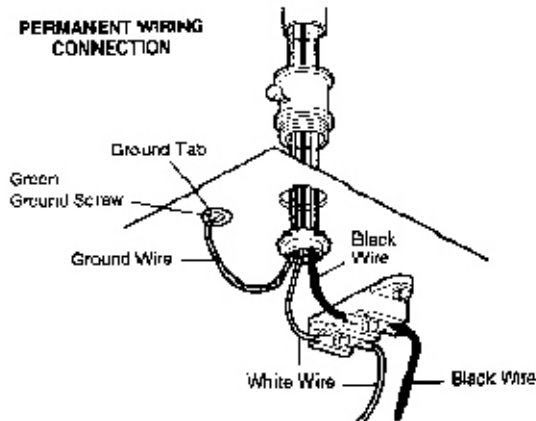
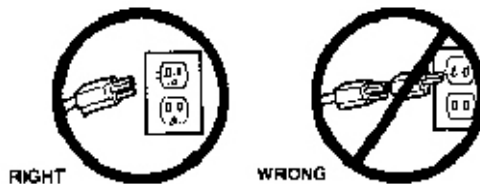

INSTALLATION

INSTALLATIONS STEP 10

WARNING!

- Be sure power is not connected to the garage door opener BEFORE installing the safety reversing sensor.
- To prevent **SERIOUS INJURY** or **DEATH** from a closing garage door:
 - Correctly connect and align the safety reversing sensor. This required safety device **MUST NOT** be disabled.
 - Install the safety reversing sensor so beam is **NO HIGHER** than 6" above garage floor.

Install The Safety Reversing Sensor

The safety reversing sensor must be connected and aligned correctly before the garage door opener will move in the down direction.

IMPORTANT INFORMATION ABOUT THE SAFETY REVERSING SENSOR

When properly connected and aligned, the sensor will detect an obstacle in the path of its electronic beam. The sending eye (with an orange indicator light) transmits an invisible light beam to the receiving eye (with a green indicator light). If an obstruction breaks the light beam while the door is closing, the door will stop and reverse to full open position, and the opener lights will flash 10 times.

The units must be installed inside the garage so that the sending and receiving eyes face each other across the door, no higher than 6" above the door as long as the sun never shines directly into the receiving eye lens. The mounting brackets are designed to clip onto the track of sectional garage doors without additional hardware.

If it is necessary to mount the units on the wall, the brackets must be securely fastened to a solid surface such as the wall framing. Extension brackets (see accessories) are available if needed. If installing in masonry construction, add a piece of wood at each location to avoid drilling extra holes in masonry if repositioning is necessary. The invisible light beam path must be unobstructed. No part of the garage door (or door tracks, springs, hinges, rollers or other hardware) may interrupt the beam while the door is closing.

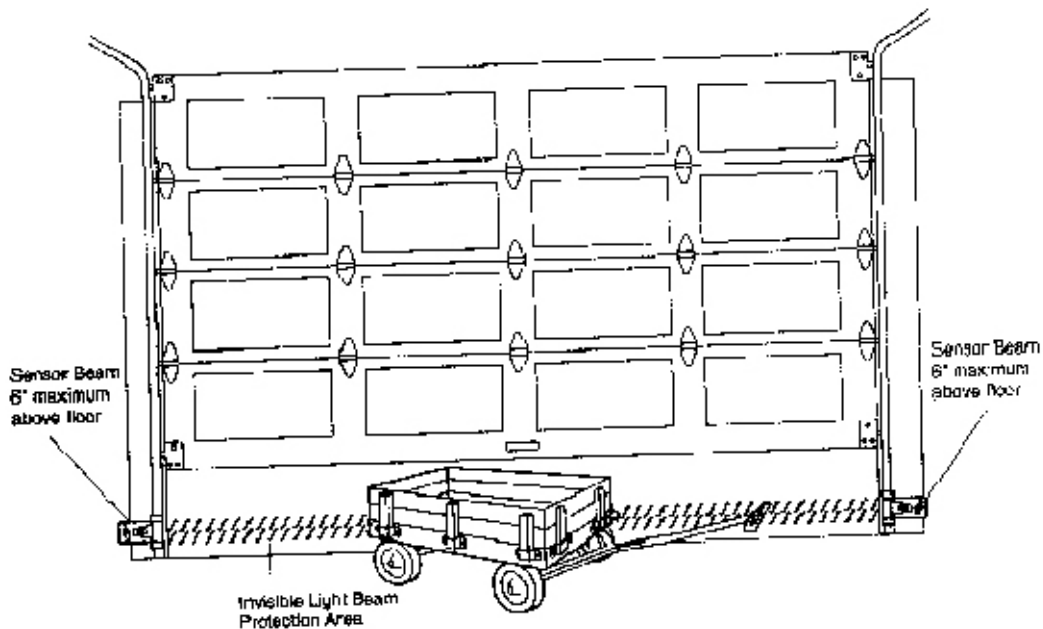

INSTALLATION

INSTALLING THE BRACKETS

Be sure power to the opener is disconnected.

Install and align the brackets so the sensors will face each other across the garage door, with the beam no higher than 6" above the floor. They may be installed in one of three ways, as follows.

Garage door track installation (preferred):

- Slip the curved arms over the rounded edge of each door track, with the curved arms facing the door. Snap into place against the side of the track. It should lie flush, with the top hugging the back edge of the track, as shown in Fig. 1. If your door track will not support the bracket securely, wall installation is recommended.

Wall installation:

- Place the bracket against the wall with curved arms facing the door. Be sure there is enough clearance for the sensor beam to be unobstructed.
- If additional depth is needed, an extension bracket (see Accessories) or wood blocks can be used.
- Use bracket mounting holes as a template to locate and drill (2) 3/16" diameter pilot holes on the wall at each side of the door, no higher than 6" above the floor.
- Attach brackets to wall with lag screws (not provided).
- If using extension brackets or wood blocks, adjust right and left assemblies to the same distance out from the mounting surface. Make sure all door hardware obstructions are cleared.

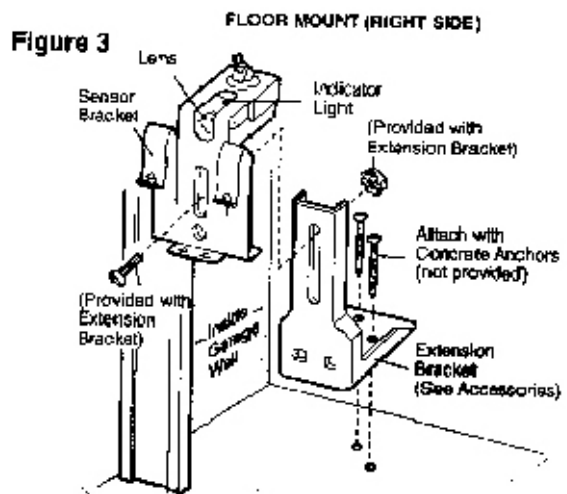
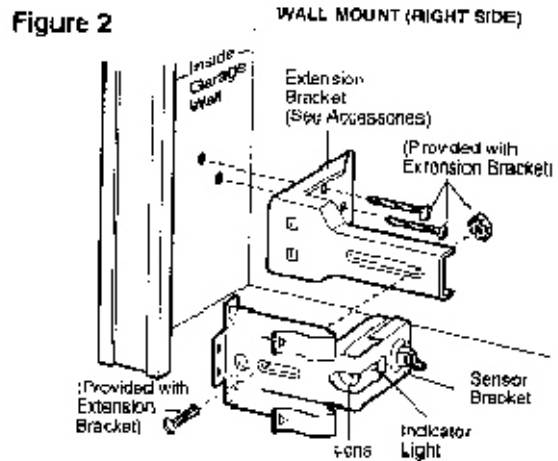
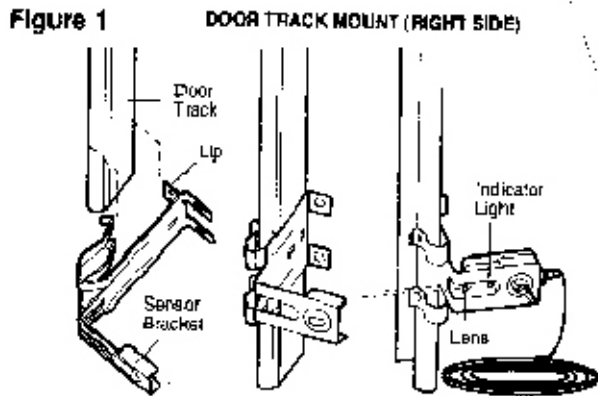

INSTALLATION

MOUNTING AND WIRING THE SAFETY SENSORS

- Slide a carriage bolt head into the slot on each sensor. Use wing nuts to fasten sensors to brackets, with lenses pointing toward each other across the door. Be sure the lens is not obstructed by a bracket extension. See fig. 4.
- Finger tighten the wing nuts.
- Run the wires from both sensors to the opener. Use insulated staples to secure wire to wall and ceiling.
- Strip 1/4" of insulation from each set of wires. Separate white, white/red, white, white/blue, white and white/black wires sufficiently to connect to the opener terminal screws: white/red to 1, white to 2, white/blue to 3 and white/black to 4.

ALIGNING THE SAFETY SENSORS

- Plug in the opener. The indicator lights in both the sending and receiving eyes will glow steadily if wiring connections and alignment are correct.
- The sending eye orange indicator light will glow regardless of alignment or obstruction. If the green indicator light in the receiving eye is off, dim, or flickering (and the invisible light beam path is not obstructed), alignment is required.
- Loosen the sending eye wing nut and readjust, aiming directly at the receiving eye. Lock in place.
 - Loosen the receiving eye wing nut and adjust sensor until it receives the sender's beam. When the green indicator light glows steadily, tighten the wing nut.

TROUBLESHOOTING THE SAFETY SENSORS

1. If the sending eye indicator light does not glow steadily after installation, check for:
 - Electric power to the opener.
 - A short in the white or white/black wires. These can occur at staples, or at screw terminal connections.
 - Incorrect wiring between sensors and opener.
 - A broken wire.
2. If the sending eye indicator light glows steadily but the receiving eye indicator light doesn't:
 - Check alignment.
 - Check for an open wire to the receiving eye.
3. If the receiving eye indicator light is dim, realign either sensor.

NOTE: When the invisible beam path is obstructed or misaligned while the door is closing, the door will or misaligned while the door is closing, the door will reverse. If the door is already open, it will not close. The opener lights will flash 10 times. See page 21.

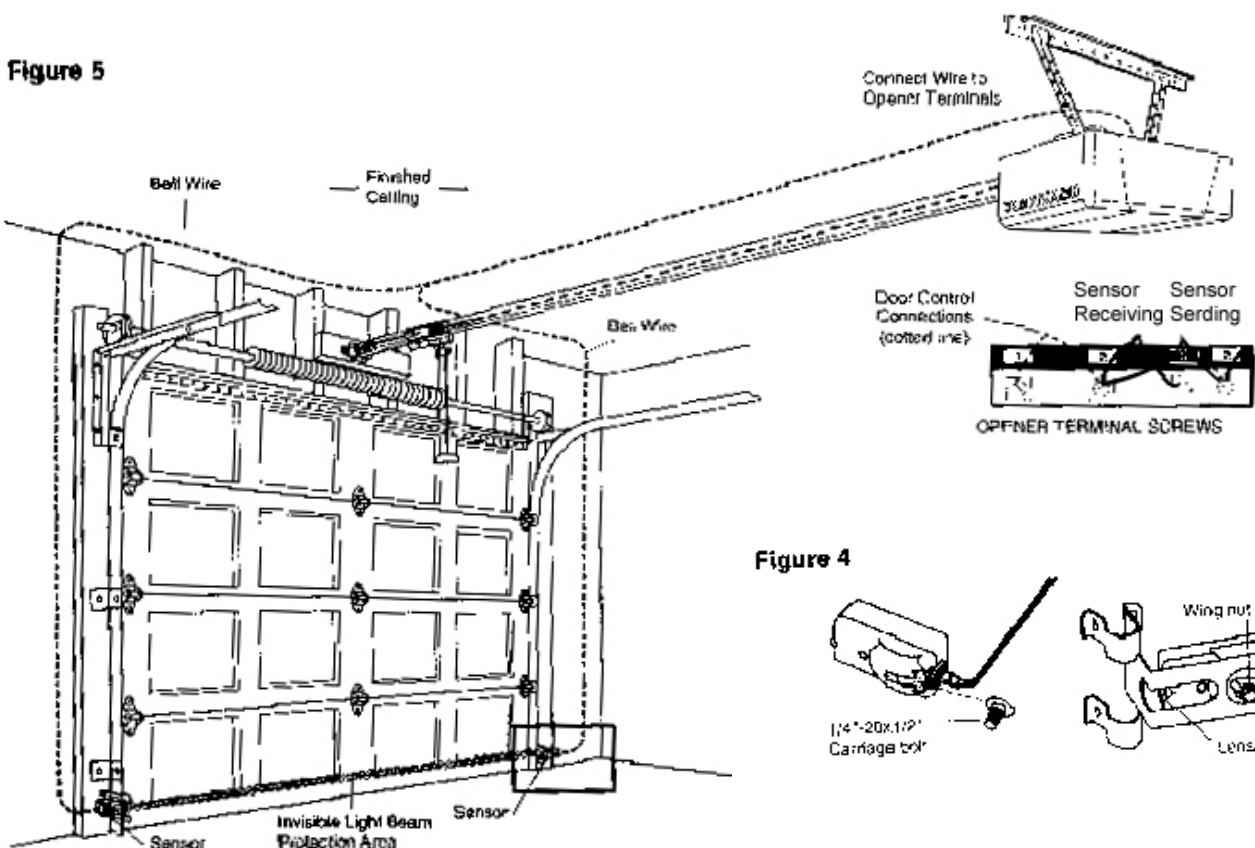

INSTALLATION

INSTALLATION STEP 11

CAUTION

To prevent damage to garage door, reinforce inside of door with angle iron both vertically and horizontally.

Fasten the Door Bracket

Follow instructions which apply to your type as illustrated below or on the following page.

A horizontal reinforcement brace should be long enough to be secured to two vertical supports. A vertical reinforcement brace should cover the height of the top panel.

The illustration shows one piece of angle iron as the horizontal brace. For vertical brace, two piece of angle iron are used to create a "U"-shaped support (Fig. 1). The best solution is to check with your garage door manufacturer for an opener installation door reinforcement kit.

NOTE: Many vertical brace installations provide for direct attachment of the clevis pin and door arm. In this case you will not need the door bracket; proceed to installation step 12.

SECTIONAL DOORS

- Center the door bracket on the previously marked vertical centerline used for the header bracket installation.

Note correct UP placement, ass stamped inside the bracket (Fig 2).

- Position the bracket on the face of the door within the following limits:

A) The top edge of the bracket 2"-4" below the top edge of the door.

B) The top edge of the bracket directly below any structural support across the top of the door.

- Mark and drill 5/16" left and right fastening holes. Secure the bracket as shown in Fig. 1 if there is vertical reinforcement.

If your installation doesn't require vertical reinforcement but does need to and bottom fastening holes for the door bracket, fasten as shown in Fig. 2.

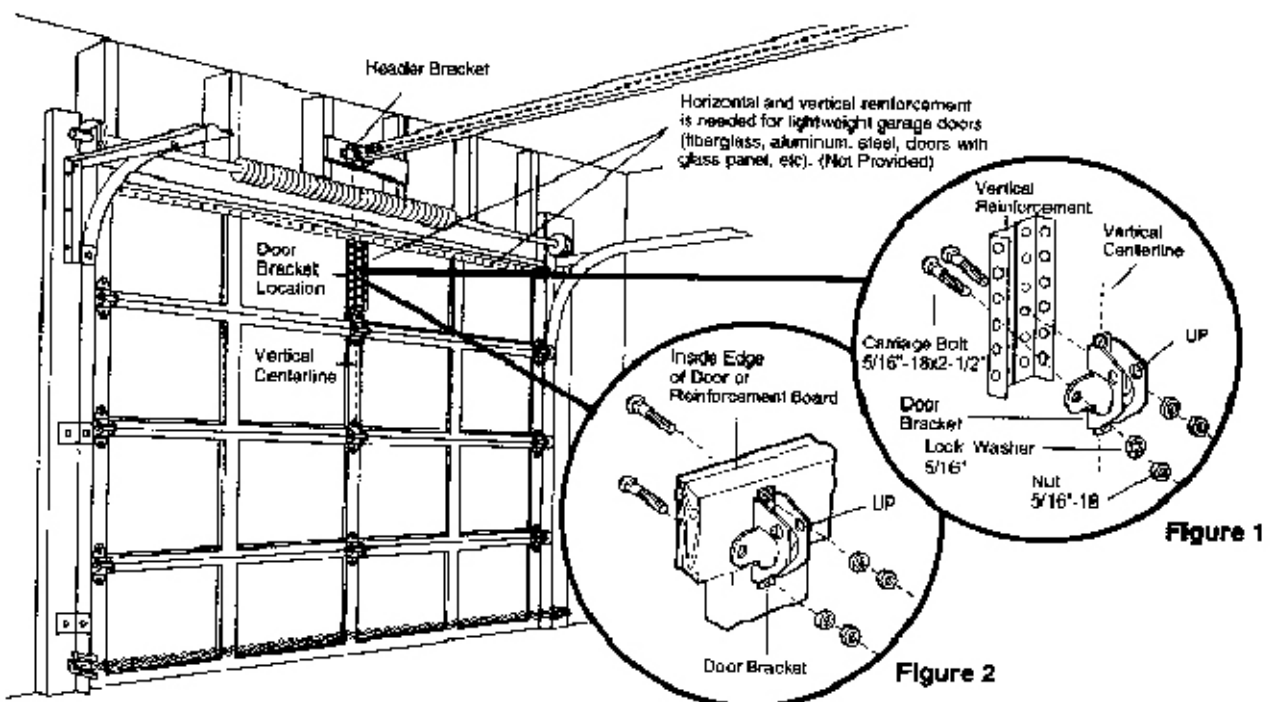

INSTALLATION

ONE-PIECE DOORS

Please read and comply with the warnings and reinforcement instructions on the previous page. They apply to one-piece doors also.

- Center the door bracket on the top of the door, in line with the header bracket as shown. Mark either the left and right, or the top and bottom holes.
- Drill 5/16" pilot holes and fasten the bracket with hardware supplied.

If the door has no exposed framing, drill 3/16" pilot holes and fasten the bracket with 5/16"x1-1/2" lag screws (not provided) to the top of the door.

NOTE: The door bracket may be installed on the top edge of the door if required for your installation. (Refer to the dotted line optional placement drawing.) Drill 3/16" pilot holes and substitute 5/16" x 1-1/2" lag screws (not provided) to fasten the bracket to the door.

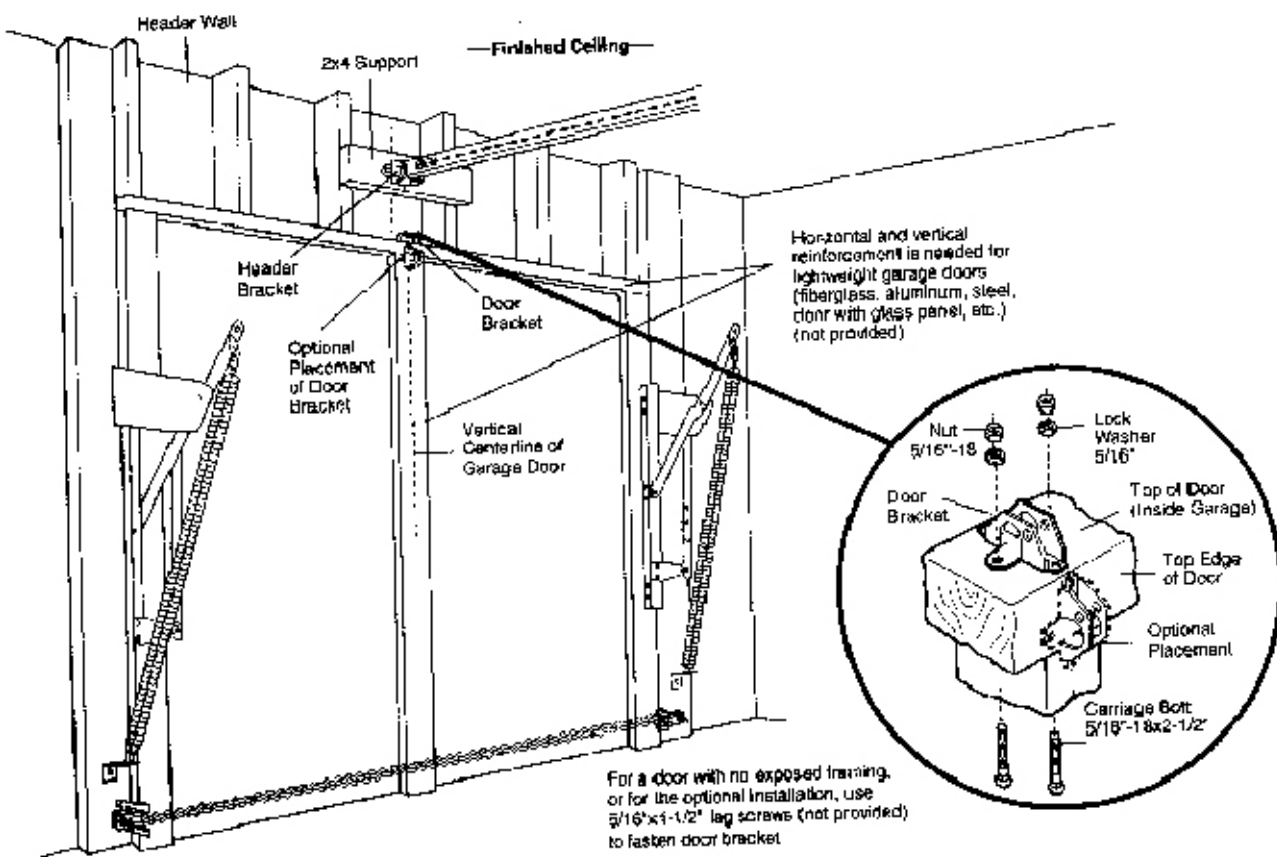

INSTALLATION

INSTALLATION STEP 12

Connect Door Arm to Trolley

Follow instructions which apply to your type as illustrated below and on the following page.

SECTIONAL DOORS ONLY

● Make sure garage door is fully closed. Pull the emergency release handle to disconnect the outer trolley from the inner trolley. Slide the outer trolley back (away from the pulley) for 8" minimum as shown in Fig. 1,2 and 3.

● Fig. 1

- Fasten straight door arm section to outer trolley with the clevis pin. Secure the connection with a split pin.
- Fasten curved section to the door bracket in the same way, using the clevis pin.

● Fig. 2

- Bring arm sections together. Find two pairs of holes that line up and join sections. Select holes as far apart as possible to increase door arm rigidity.

● Fig.3, Hole alignment alternative:

- If holes in curved arm are above holes in straight arm, disconnect straight arm. Cut about 6" from the solid end. Reconnect to trolley with cut end down as shown.
- Bring arm sections together.
- Find two pairs of holes that line up and join with screws, lock washers and nuts.

Pull the emergency release handle toward the opener at a 45° angle so that the trolley release arm is horizontal. Proceed to Adjustment Step 1, page 28. Trolley will re-engage automatically when opener is operated.

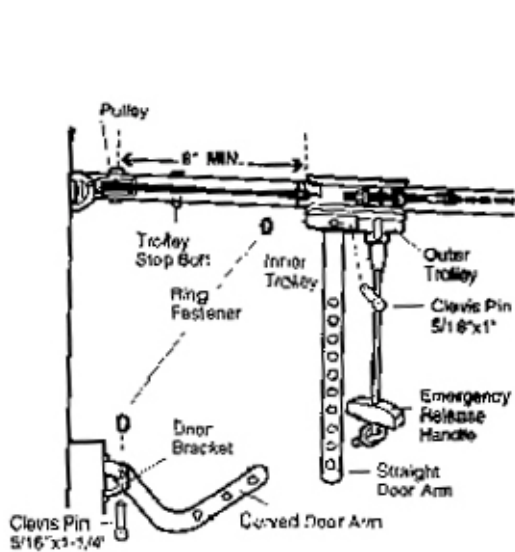

Figure 1

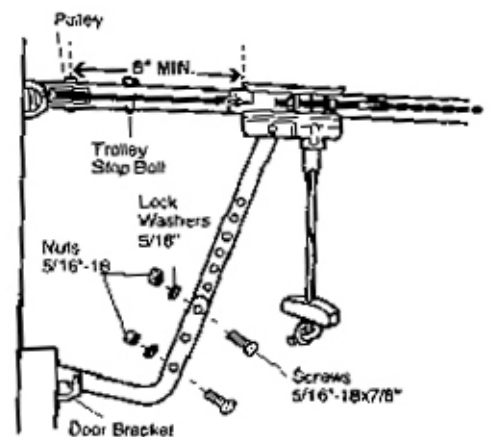

Figure 2

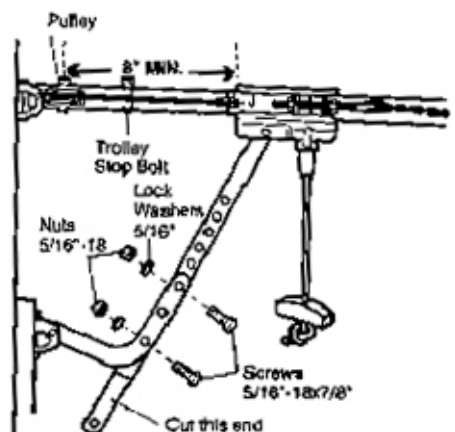

Figure 3

INSTALLATION

ALL ONE-PIECE DOORS

1. Assemble the door arm, fig. 4:

- Fasten the straight and curved door arm sections together to the longest possible length (with a 2 or 3 hole overlap).
- With the door closed, connect the straight door arm section to the door bracket with the clevis pin.
- Secure with a ring fastener.

2. Adjustment procedures, Fig. 5:

On one-piece doors, before connecting the door arm to the trolley, the travel limits must be adjusted. Limit adjustment screws are located on the left side panel as shown on page 28. Follow adjustment procedures below.

- Open door adjustment: decrease UP travel limit
 - Turn the UP limit adjustment screw counter-clockwise 5 1/2 turns.
 - Press the Door Control push button. The trolley will travel to the fully open position.
 - Manually raise the door to the open position (parallel to the floor), and lift the door arm to the trolley. The arm should touch the trolley just in back of the door arm connector hole. Refer to the fully open trolley/door arm positions in the illustration. If the arm does not extend far enough, adjust the limit further. One full turn equals 2" of trolley travel.
 - Closed door adjustment: decrease DOWN travel limit
 - Turn the DOWN limit adjustment screw clockwise 5 complete turns.
 - Press the Door Control push button. The trolley will travel to the fully closed position.
 - Manually close the door and lift the door arm to the trolley. The arm should touch the trolley just ahead of the door arm connector hole. Refer to the fully closed trolley/door arm positions in the illustration. If the arm is behind the connector hole, adjust the limit further. One full turn equals 2" of trolley travel.
- ### 3. Connect the door arm to the trolley:
- Close the door and join the curved arm to the connector hole in the trolley with the remaining clevis pin. It may be necessary to lift the door slightly to make the connection.
 - Secure with a ring fastener.
 - Run the opener through a complete travel cycle. If the door has a slight "backward" slant in full open position as shown in the illustration, decrease the UP limit until the door is parallel to the floor.

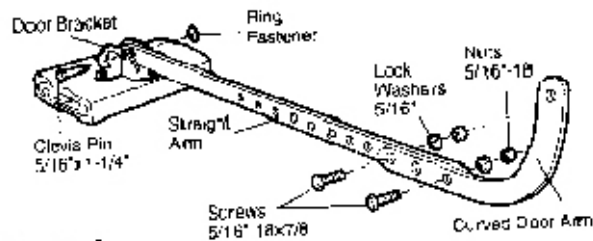

Figure 4

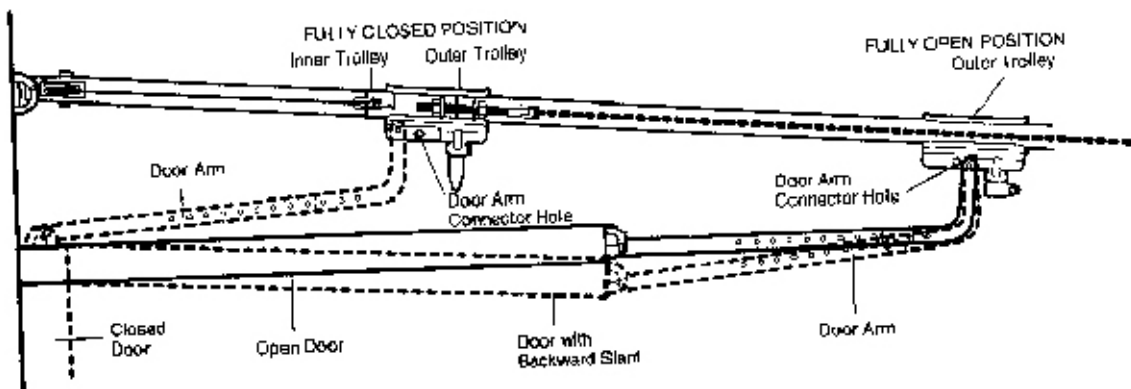

Figure 5

ADJUSTMENT

ADJUSTMENT STEP 1

Adjust the UP and DOWN Travel Limits

WARNING !

Without a properly installed safety reversal system, persons (particularly small children) could be SERIOUSLY INJURED or KILLED by a closing garage door.

- Incorrect adjustment of garage door travel limits will interfere with proper operation of safety reversal system.
- If one control (force or travel limits) is adjusted, the other control may also need adjustment.
- After any adjustments are made, the safety reversal system MUST be tested. Door MUST reverse on contact with one-inch high object (or 2x4 laid flat) on floor.

CAUTION!

To prevent damage to vehicles, be sure fully open door provides adequate clearance.

Limit adjustment settings regulate the points at which the door will stop when moving up or down.

To operate the opener, press the Door Control push button. Run the opener through a complete travel cycle.

- Does the door open and close completely ?
- Does the door stay closed and not reverse unintentionally when fully closed ?

If your door passes both of these test, no limit adjustments are necessary unless the reversing test fails (see Adjustment Step 3, page 30).

Adjustment procedures are outlined below. Read the procedures carefully before proceeding to Adjustment Step 2. Use a screwdriver to make limit adjustments. Run the opener through a complete travel cycle after each adjustment.

NOTE: Repeated operation of the opener during adjustment procedures may cause the motor to overheat and shut off. Simply wait 15 minutes and try again.

NOTE: If anything interferes with the door's upward travel, it will stop. If anything interferes with the door's downward travel (including binding or unbalanced doors), it will reverse.

HOW AND WHEN TO ADJUST THE LIMITS

- If the door does not open completely but opens at least five feet:
Increase up travel. Turn the UP limit adjustment screw clockwise. One turn equals 2" of travel.

NOTE: To prevent the trolley from hitting the cover protection bolt, keep a minimum distance of 2-4" between the trolley and the bolt.

- If door does not open at least 5 feet:
Adjust the UP (open) force as explained in Adjustment Step 2.
- If the door does not close completely:
Increase down travel. Turn the down limit adjustment screw counterclockwise. One turn equals 2" of travel.
If door still won't close completely, try lengthening the door arm (page 26) and decreasing the down limit.
- If the opener reverses in fully closed position:
Decrease down travel. Turn the down limit adjustment screw clockwise. One turn equals 2" of travel.
- If the door reverses when closing and there is no visible interference to travel cycle:
If the opener lights are flashing, the Safety Reversing Sensors are either not installed, misaligned, or obstructed. See Troubleshooting, page 23.

Test the door for binding: Pull the emergency release handle. Manually open and close the door. If the door is binding, call a trained door systems technician. If the door is not binding or unbalanced, adjust the DOWN (close) force. See Adjustment Step 2.

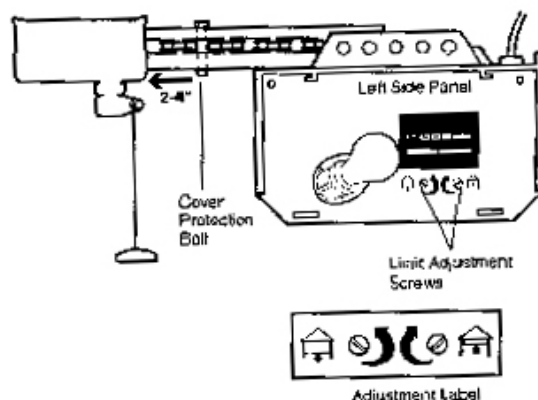

ADJUSTMENT

ADJUSTMENT STEP 2

Adjust the Force

WARNING!

Without a properly installed safety reversal system, persons (particularly small children) could be SWEIIOOUSLY INJURES or KILLED by a closing garage door.

- Too much force on garage door will interfere with proper operation of safety reversal system.
- NEVER use force increase force beyond minimum amount required to close garage door.
- NEVER use force adjustments to compensate for binding or sticking garage door.
- If one control (force or travel limits) is adjusted, the other control may also need adjustment.
- After any adjustments are made, the safety reversal system MUST be tested. Door MUST reverse on contact with one-inch high object (or 2x4 laid flat) on floor.

Force adjustment controls are located on the right side panel of the motor unit. Force adjustment settings regulate the amount of power required to open and close the door. If the forces are set too light, door travel may be interrupted by nuisance reversals in the down direction and stops in the up direction. Weather conditions can affect the door movement, so occasional adjustment may be needed.

The maximum force adjustment range is about 3/4 of a complete turn. Do not force controls beyond that point. Turn force adjustment controls with a screwdriver.

NOTE: If anything interferes with the door's upward travel, it will stop. If anything interferes with the door's downward travel (including binding or unbalanced doors), it will reverse.

HOW AND WHEN TO ADJUST THE FORCES

1. Test the DOWN (close) force

- Grasp the door bottom when the door is about halfway through DOWN (close) travel. The door should reverse. Reversal Halfway through down travel does not guarantee reversal on a one-inch obstruction. See Adjustment Step 3, page 30. If the door is hard to hold or doesn't reverse, DECREASE the DOWN (close) force by turning the control counterclockwise. Make small adjustments until the door reverses normally. After each adjustment, run the opener through a complete cycle.
- If the door reverses during the down (close) cycle and the opener lights are not flashing, INCREASE DOWN (close) force by turning the control clockwise. Make small adjustments until the door completes a close cycle. After each adjustment, run the opener through a complete travel cycle. Do not increase the force beyond the minimum amount required to close the door.

3. Test the UP (open) force

- Grasp the door bottom when the door is about halfway through UP (open) force by turning the control counterclockwise. Make small adjustments until the door stops easily and opens fully. After each adjustment, run the opener through a complete travel cycle.
- If the door does not open at least 5 feet, INCREASE UP (Open) force by turning the control clockwise. Make small adjustments until door opens completely. Readjust the UP limit if necessary. After each adjustment, run the opener through a complete travel cycle.



Adjustment Label

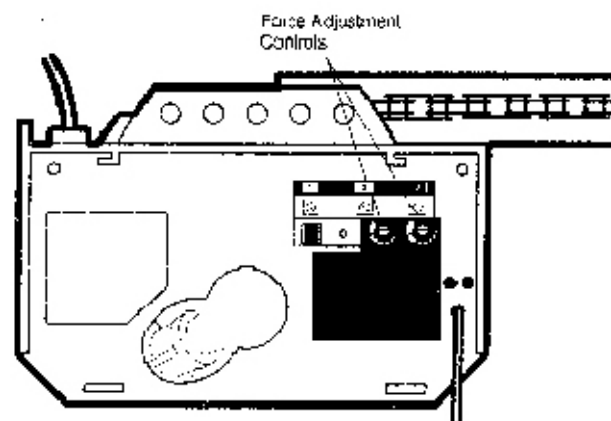

Right Side Panel

ADJUSTMENT

ADJUSTMENT STEP 3

Test the Safety Reversal System

WARNING!!

Without a properly installed safety reversal system, persons (particularly small children) could be **SERIOUSLY INJURED** or **KILLED** by a closing garage door.

- Safety reversal system **MUST** be tested every month.
- If one control (force or travel limits) is adjusted, the other control may also need adjustment.
- After **ANY** adjustments are made, the safety reversal system **MUST** be tested. Door **MUST** reverse on contact with one-inch high object (or 2x4 laid flat) on the floor.

TEST

- With the door fully open, place a one-inch board (or a 2x4 laid flat) on the floor, centered under the garage door.
- Operate the door in the down direction. The door must reverse on striking the obstruction.

ADJUST

- If the door stops on the obstruction, it is not raveling far enough in the down direction. Increase the **DOWN** limit by turning the **DOWN** limit adjustment screw counterclockwise 1/4 turn.

NOTE: On a sectional door, make sure limit adjustments do not cause the trolley to move within 2-1/2" of the trolley stop bolt. If necessary lengthen straight door arm to maintain this minimum distance.

- Repeat the test.
- When the door reverses on the one-inch board, remove the obstruction and run the opener through 3 or 4 complete travel cycles to test adjustment.

IMPORTANT SAFETY CHECK:

Repeat Adjustment Steps 1, 2 and 3 after:

- Each adjustment of door arm length, limits, or force controls.
- Any repair to or adjustment of the garage door (including spring and hardware).
- Any repair to or buckling of the garage floor.
- Any repair to or adjustment of the opener.

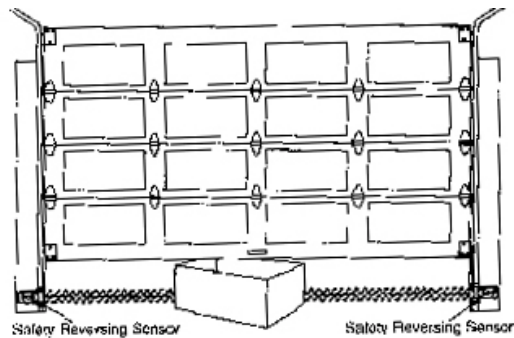
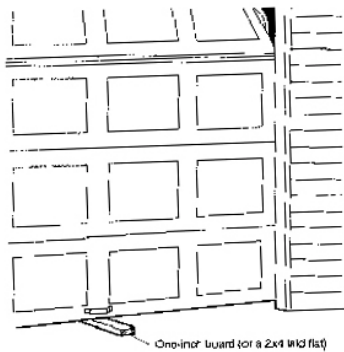

ADJUSTMENT STEP 4

Test the Safety Reversing Sensor

Without a properly installed safety reversing sensor, persons (particularly small children) could be **SERIOUSLY INJURED** or **KILLED** by a closing garage door.

- Press the remote control push button to open the door.
- Place the opener carton in the path of the door.
- Press the remote control push button to close the door. The door will not move, and the opener lights goes out, but the warning lights will flash.

The garage door opener will not close from a remote if the indicator light in either sensor is off (alerting you to the fact that the sensor is misaligned or obstructed).

If the opener closes the door when the safety reversing sensor is obstructed (and the sensors are no more than 6" above the floor), call for a trained door systems technician.

OPERATION

IMPORTANT SAFETY INSTRUCTIONS

WARNING!!

This device complies with Part 15 of the FCC Rules. Operation is subject to the following two conditions: (1) this device may not cause harmful interference, and (2) this device must accept any interference received, including interference that may cause undesired operation.

TO REDUCE THE RISK OF SEVERE INJURY OR DEATH:

1. READ AND FOLLOW ALL WARNINGS AND INSTRUCTIONS.
2. ALWAYS keep remote controls out of reach of children. NEVER permit children to operate or play with garage door control push buttons or remote controls.
3. ONLY activate garage door when it can be seen clearly, it is properly adjusted, and there are no obstructions to door travel.
4. ALWAYS keep garage door in sight until completely closed. NO ONE SHOULD CROSS THE PATH OF THE MOVING DOOR.
5. If possible, use emergency release handle to disengage trolley ONLY when garage door is CLOSED. Weak or broken springs or unbalanced door could result in an open door falling rapidly and/or unexpectedly.
6. NEVER use emergency release handle unless garage doorway is clear of persons and obstructions.
7. NEVER use handle to pull garage door open or closed. If rope knot becomes untied, you could fail.
8. If one control (force or travel limits) is adjusted, the other control may also need adjustment.
9. After any adjustments are made, the safety reversal system MUST be tested.
10. Safety reversal system MUST reverse on contact with one-inch high object (or a 2x4 laid flat) on the floor.
11. ALWAYS KEEP GARAGE DOOR PROPERLY BALANCED (see page 3). An improperly balanced door may not reverse when required and could result in severe injury or death.
12. All repairs to cables, spring assemblies and other hardware, all of which are under EXTREME tension, MUST be made by a trained door systems technician.
13. ALWAYS disconnect electric power to garage door opener before making any repairs or removing covers.
14. SAVE THESE INSTRUCTIONS.

Using Your Garage Door Opener

Your Security+ opener and hand-held remote control have been factory-set to a matching code which changes with each use, randomly accessing over 2^{66} new codes. Your opener will operate with up to eight Security+ remote controls and one Security+ Keyless Entry System. If you purchase a new remote, or if you wish to deactivate any remote, follow the instructions in the Programming section.

Activate your opener with any of the following:

- The hand-held Remote Control: Hold the large push button down until the door starts to move.
- The wall-mounted Door Control: Hold the push button down until the door starts to move.
- The Keyless Entry (See Accessories): If supplied with your garage door opener, it must be programmed before use. See programming.

When the opener is activated (with the safety reversing sensor correctly installed and aligned)

1. If open, the door will close. If closed, it will open.
2. If closing, the door will reverse.
3. If opening, the door will stop.
4. If the door has been stopped in a partially open position, it will close.
5. If obstructed while closing, the door will reverse. If the obstruction interrupts the sensor beam, the opener lights will blink for five seconds.
6. If obstructed while opening, the door will stop.
7. If fully open, the door will not close when the beam is broken. The sensor has no effect in the opening cycle.

If the sensor is not installed, or is misaligned, the door won't close from a hand-held remote. However, you can close the door with the Door Control, the Outdoor Key Switch, or Keyless Entry, if you activate them until down travel is complete. If you release them too soon, the door will reverse.

The opener lights will turn on under the following conditions: when the opener is initially plugged in; when power is restored after interruption; when the opener is activated.

They will turn off automatically after 3 minutes or provide constant light when the Light feature on the Premium Control Console is activated. Bulb size is 100 watts maximum.

Security+ Light Feature: Lights will also turn on when someone walks through the open garage door. With a Premium Control Console, this feature may be turned off as follows: With the opener lights off, press and hold the light button for 6 seconds, until the light goes on and off again. To restore this feature, start with the opener lights on, then press and hold the light button for 6 seconds until the light goes off, then on again.

OPERATION

Using the Wall-Mounted Door Control

Press the lighted push button to open or close the door. Press again to reverse the door during the closing cycle or to stop the door while it's opening.

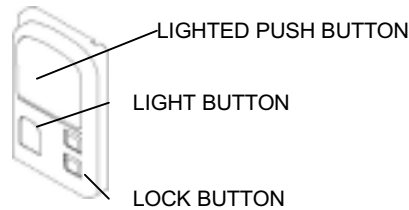

THE PREMIUM CONTROL CONSOLE

Light feature

Press the Light button to turn the opener light on or off. It will not control the opener lights when the door is in motion. If you turn it on and then activate the opener, the light will remain on for 3 minutes. Press again to turn it off sooner.

Lock Feature

Designed to prevent operation of the door from hand-held remote controls. However, the door will open and close from the Door Control, the Outdoor Key Switch.

To activate, press and hold the Lock button for 1 second. The push button light will flash as long as the Lock feature is on.

To turn off, press and hold the Lock button again for 1 second. The push button light will stop flashing. The Lock feature will also turn off whenever the SRT (Smart Receiver/Transmitter) button on the motor unit panel is activated or the PUSH button on the control console to operating the door.

Additional feature when used with the 3-function hand-held remote

To control the opener lights:

In addition to operation the door, you may program the remote to operate the lights.

1. With the door closed, press and hold a small remote button that you want to control the light.
2. Press and hold the Light button on the Premium Console.
3. While holding the Light button, press and hold the Lock button on the door control.
4. After the opener lights flash, release all buttons.



To Open the Door Manually

WARNING!!

- To prevent possible **SERIOUS INJURY** or **DEATH** from a falling garage door:
 - If possible, use emergency release handle to disengage trolley **ONLY** when garage door is **CLOSED**. Weak or broken springs or unbalanced door could result in an open door falling rapidly and/or unexpectedly.
 - **NEVER** use emergency release handle unless garage doorway is clear of persons and obstructions.
- **NEVER** use handle to pull door open or closed. If rope knot becomes untied, you could fail.

DISCONNECT THE TROLLEY:

The door should be fully closed if possible. Pull down on the emergency release handle (so that the trolley release arm snaps into a vertical position) and lift the door manually. The lockout feature prevents the trolley from reconnecting automatically, and the door can be raised and lowered manually as often as necessary.

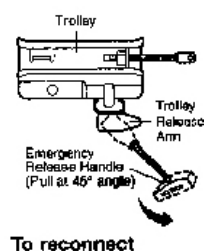
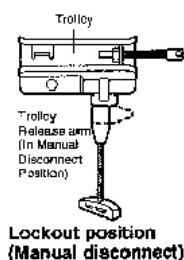

TO RE-CONNECT THE TROLLEY:

Pull the emergency release handle toward the opener at a 45° degree angle so that the trolley release arm is horizontal. The trolley will reconnect on the next UP or DOWN operation, either manually or by using the door control or remote.

OPERATION

Care of Your Opener

Warning: Changes or modifications to this unit not expressly approved by the party responsible for compliance could void the user authority to operate the equipment.

NOTE: This equipment has been tested and found to comply with the limits for a Class B digital device, pursuant to Part 15 of the FCC Rules. These limits are designed to provide reasonable protection against harmful interference in a residential installation. This equipment generates, uses and can radiate radio frequency energy and, if not installed and used in accordance with the instructions, may cause harmful interference to radio communications.

LIMIT AND FORCE ADJUSTMENTS:

Weather conditions may cause some minor changes in door operation requiring some re-adjustments, particularly during the first year of operation. Pages 28 and 29 refer to the limit and force adjustments. Only a screwdriver is required. Follow the instructions carefully.

Repeat the safety reverse test (page 30) after any adjustment of limits or force.



MAINTENANCE SCHEDULE

Once a Month

- Manually operate door. If it is unbalanced or binding, call a trained door systems technician.
- Check to be sure door opens & closes fully. Adjust limits and/or force if necessary. (See pages 28 and 29.)
- Repeat the safety reverse test. Make any necessary adjustments. (See Adjustment Step 3.)

Twice a Year

- Check chair, tension. Disconnect trolley first. Adjust if necessary (See page 11).

Once a Year

- Oil door rollers, bearings and hinges. The opener does not require additional lubrication. Do not grease the door tracks.

THE REMOOTE CONTROL BATTERY

WARNING!!

To prevent possible SERIOUS INJURY or DEATH:

- NEVER allow small children near batteries.
- If battery swallowed, immediately notify doctor.

To replace battery, use the visor clip or screwdriver blade to pry open the case as shown. Insert battery positive side up. Dispose of old battery properly.

3-FUNCTION OPEN
this end first to avoid cracking
housing



NOTICE: To comply with FCC and/or INDUSTRY Canada rules, adjustment or modifications of this receiver and/ or this receiver and/ or transmitter are prohibited, except for changing the code setting or replacing the battery. THERE ARE NO OTHER USER SERVICEABLE PARTS.

TROUBLESHOOTING

Having a Problem?

1. The opener doesn't operate from either the Door Control or the remote control:
 - Does the opener have electric power? Plug a lamp into the outlet. If it doesn't light, check the fuse box or the circuit breaker. (Some outlets are controlled by a wall switch.)
 - Have you disabled all door locks? Review installation instruction warnings on page 11.
 - Is there a build-up of ice or snow under the door? The door may be frozen to the ground. Remove any restriction.
 - The garage door spring may be broken. Have it replaced.
 - Repeated operation may have tripped the overload protector in the motor. Wait 15 minutes and try again.
2. Opener operates from the remote, but not from the Door Control:
 - Is the door control lit? if not, remove the bell wire from the motor unit terminals, Short the red and white terminals by touching both terminals at the same time with a piece of wire. If the opener runs, check for a faulty wire connection at the door control, a short under the staples, or a broken wire.
 - Are the wiring connections correct? Review Installation Step 6, page 18.
3. The door operates from the Door Control, but not from the remote control:
 - Is the door push button flashing? If your model has the Lock feature, make sure it is off.
 - Program the opener to match the remote control code. (Refer to instructions on the motor unit panel.) Repeat with all remotes.
4. The remote has short range:
 - Change the location of the remote control in your car.
 - Check to be sure the antenna on the side or back panel of motor unit extends fully downward.
 - Some installations may have shorter range due to a metal door, foil backed insulation, or metal garage siding.
5. Opener noise is disturbing in living quarters of home:
 - If operational noise is a problem because of proximity of the opener to the living quarters, the Vibration Isolator **Kit 41A3263** can be installed. This kit was designed to minimize vibration to the house and is easy to install.
6. The garage door opens and closes by itself:
 - Be sure that all remote control push buttons are off.
 - Remove the bell wire from the door control terminals and operate from the remote only. If this solves the problem, the door control is faulty (replace), or there is an intermittent short on the wire between the door control and the motor unit.
 - Clear memory and re-program all remote controls.
7. The door doesn't open completely:
 - Is something obstructing the door? Is it out of balance, or are the springs broken? Remove the obstruction or repair the door.
 - If the door is in good working order but now doesn't open all the way, increase the up force. See Adjustment Step 2.
 - If the door opens at least 5 feet, the travel limits may need to be increased. One turn equals 2 inches of travel. See Adjustment Step 1.

Repeat the safety reverse test after the adjustment is complete.
8. The door stops but doesn't close completely:
 - Review the travel limits adjustment procedures on page 28.

Repeat the safety reverse test after any adjustment of door arm length, close force or down limit.
9. The door opens but won't close:
 - If the opener lights blink, check the safety reversing sensor. See Installation Step 10.
 - If the opener lights don't blink and it is a new installation, check the down force. See Adjustment Step 2, page 29. For an existing installation, see below.

Repeat the safety reverse test after the adjustment is complete.
10. The door reverse for no apparent reason and opener lights don't blink:
 - Is something obstructing the door? Pull the emergency release handle. Operate the door manually. If it is unbalanced or binding, call a trained door systems technician.
 - Clear any ice or snow from the garage floor area where the door closes.
 - Review Adjustment Step 2 on page 29.
 - If door reverses in the fully closed position, decrease the travel limits (Adjustment Step 1).

Repeat safety reverse test after adjustments to force or travel limits. The need for occasional adjustment of the force and limit settings is normal. Weather conditions in particular can affect door travel.

11. The door reverses for no apparent reason and warning lights blink for 3 seconds after reversing:
 - Check the safety reversing sensor. Remove any obstruction or align the receiving eye. See Installation Step 10.
12. The opener lights don't turn on:
 - Replace the light bulbs (100 watts maximum). Use a standard neck garage door opener bulb if regular bulb burns out.
13. The Opener Lights Don't Turn Off:
 - Is the Light feature on? Turn it off.
14. The opener strains or maximum force is needed to operate door:
 - The door may be out of balance or the springs may be broken. Close the door and use the emergency release handle to disconnect the trolley. Open and close the door manually. A properly balanced door will stay in any point of travel while being supported entirely by its springs. If it does not, disconnect the opener and call a trained door systems technician. Do not increase the force to operate the opener.
15. The opener motor hums briefly, then won't work:
 - The garage door springs may be broken. See above.
 - If the problem occurs on the first operation of the opener, door may be locked. Disable the door lock. If the chain was removed and reinstalled, the motor may be out of phase. Remove the chain; cycle the motor to the down position. Observe the drive sprocket. When it turns in a clockwise direction and stops in the down position, reinstall the chain.

Repeat the safety reverse test after the adjustment is complete.

16. The opener won't operate due to power failure:
 - Use the emergency release handle to disconnect the trolley. The door can be opened and closed manually. When power is restored, press the Door Control push button and trolley will automatically reconnect (unless trolley is in lockout position.) See page 32.
 - The Emergency Key Release accessory (for use on garages with no service door) disconnects the trolley from outside the garage in case of power failure.
17. The chain droops or sags:
 - It is normal for the chain to droop slightly in the closed door position. Use the emergency release to disconnect the trolley. If the chain returns to normal height when the trolley is disengaged and the door reverses on a one-inch board, no adjustments are needed (See page 11).

PROGRAMMING

Your garage door opener has already been programmed at the factory to operate with your hand-held remote control. The door will open and close when you press the first push button.

Below are instructions for programming your opener to operate with additional Security+ remote controls.

To add an Additional Hand-held remote control

USING THE "LEARN" BUTTON

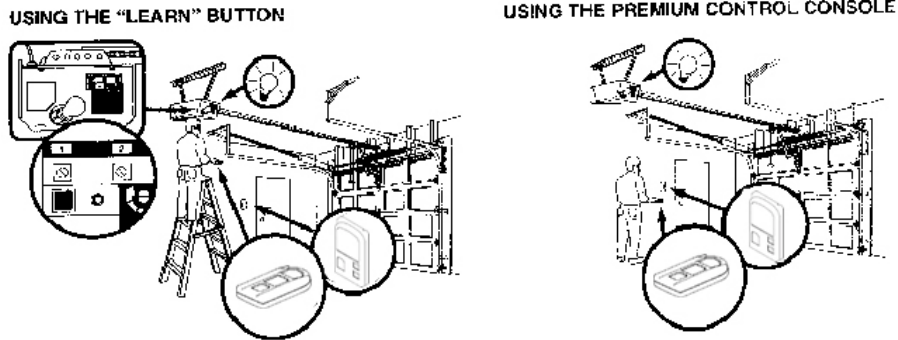

1. Press and release the "learn" button on the motor unit. The learn indicator light and warning light will glow steadily for 30 seconds.
2. Within 30 seconds, press the third push button on the remote control until learn indicator light and warning light goes out.
3. Within 30 seconds, press and hold the button on the hand-held remote* that you wish to operate your garage door.
4. Release the button when the learn indicator light and warning ware snuff out. It has learned the code.

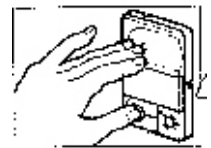
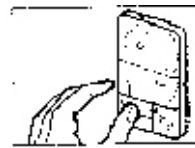
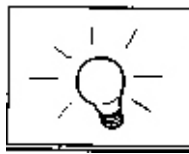
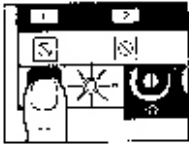

USING THE PREMIUM CONTROL CONSOLE

1. Press and hold the LIGHT button on the control console then press the lock button, continue pressing the both buttons over 1 second. The push button LIGHT button indicator light blinks quickly and warning light stays on.
2. Within 30 seconds, press and hold the three button until the push button LIGHT and warning will blink three time. (If the remote control has been learned, then do not need this step)
 - (1) Add / Change functions of the PUSH button: Press and hold the button on the remote control that your wish to set, and press the PUSH button until the push button LIGHT and warning light will blink twice.
 - (2) Add / Change functions of the LIGHT button: Press and hole the button on the remote control that your wish to set, and press the LIGHT button until the push button LIGHT and warning light will blink twice.
 - (3) Add / Change functions of the OUTLET button: Press and hole the button on the remote control that your wish to set, and press the OUTLET button until the push button LIGHT and warning light will blink twice.
 - (4) Cancel the function of certain button temporarily: Press and hole the button on the remote control that your wish to cancel, and press the LOCK button until the push button LIGHT and warning light will blink twice.
3. When you want to learn the other remote control, repeat 2. After the remote control learns, press and hold the push button LIGHT and LOCK button. It will quit the learn model, and the push button LIGHT stops blanking, and warning light goes out.

To Erase All Codes From Motor Unit Memory

To deactivate any unwanted remote, first erase all codes:

Press and the hold "learn" button on motor unit until the learn indicator light and warning light goes out

(approximately 6 seconds. All previous codes are now erased. Reprogram each remote or Keyless entry your wish to use.

*3-Function Remotes

If supplied with your garage door opener, the large button is factory programmed to operate it. Additional buttons on any Security+ 3-function remote or compact remote can be programmed to operate other security+ garage door openers.

To Add or Change a Keyless Entry PIN

NOTE: Your new Keyless Entry must be programmed to operate your garage door opener.
USING THE "LEARN" BUTTON

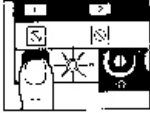

1. Press and release the "learn" button on motor unit. The learn indicator light and warning light will glow steadily for 30 seconds.



2. Within 30 seconds, enter a four digit personal identification number (PIN) of your choice on the keypad. Then press and hold the ENTER button.



3. Release the button when the learn indicator light and warning light goes out. It has learned the code.

USING THE "LEARN" BUTTON

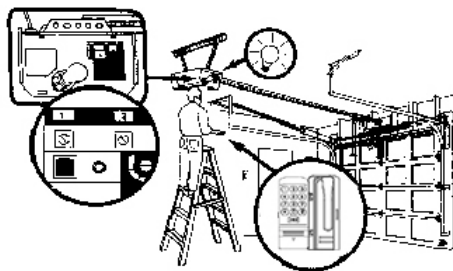

USING THE PREMIUM CONTROL CONSOLE

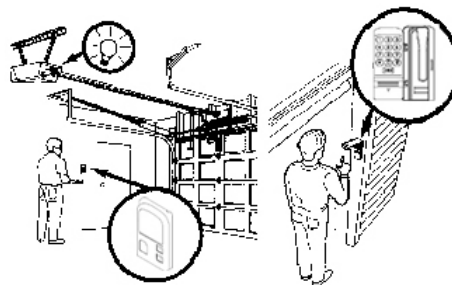

USING THE PREMIUM CONTROL CONSOLE

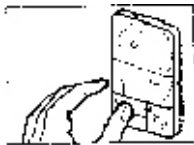

1. Press and hold the LIGHT button on the premium control console then press the LOCK button, continue pressing the both buttons over 1 second, the PUSH button light indicator light and warning light blinks quickly and warning light stays on.



2. Within 30 seconds, enter a four digit PIN of your choice on the keypad. Then press and hold the ENTER button, until the PUSH button light and warning double blinks. Then PIN has learned successfully and remote control will quit the learn model.

To change an existing, known PIN

If the existing PIN is known, it may be changed by on person without using a ladder.

1. Press the four buttons for the present PIN, then press and hold the # button.
The PUSH button light blinks quickly and warning light stays on. Release the # button.
2. within 15 seconds, press the new 4-digit PIN you have chose, then press Enter.
The PUSH button light and warning light double blinks when the PIN has been learned.
Test by pressing the new PIN, then press Enter. The door should move.

To set a Slave PIN

1. Press the 4 buttons for your personal entry Master PIN, then press and hold the * button. Until the PUSH button light blinks quickly and warning light stays on.
2. Within 15 seconds, press the 4 buttons for your personal entry Slave PIN (can not set as 0000), then press and hold the * button.
3. The PUSH button light and warning light will blink twice when the Slave PIN has been added successfully.

To erase a Slave PIN

1. Press the 4 button for your personal entry Master PIN, then press and hold the * button. Until the PUSH button light stays on.
2. Within 15 seconds, enter 0000 continue and press and hold ENTER button.
3. The PUSH button light and warning light will blink twice when the Slave PIN has been erase successfully.