

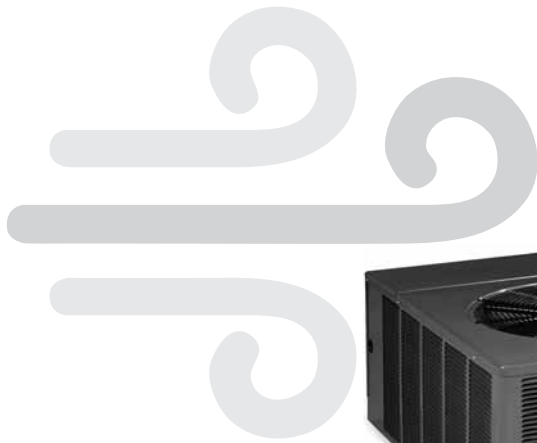

The new degree of comfort.™

Rheem *Classic*® Series Air Conditioners



RANL- Series

Efficiencies up to 14.50 SEER/12.50 EER
Nominal Sizes 1.5-5 Ton [5.27 to 17.6 kW]
Cooling Capacities 18.3 to 62 kBTU
[5.36 to 18.17 kW]



- Attractive, louvered wrap-around jacket protects the coil from yard hazards and weather extremes. Top grille is steel reinforced for extra strength. Cabinet is powder painted for all-weather protection.
- Air is discharged upward away from bushes and shrubs. The discharge pattern of the top grille provides minimum air restriction.
- Combination Grille/Motor Mount secures the motor to the underside of the discharge grille. The grille protects the motor windings and bearings from rain and snow.
- All controls are accessible by removing one service panel. Removable top grille provides access to the condenser fan motor and condenser coil.
- Single speed 8-pole fan motor designed for low speed, quiet, energy-saving operation.
- All models meet or exceed a 1000-hour salt spray test per ASTM B117 Standard Practice for Operating Salt Spray Testing Apparatus.

TABLE OF CONTENTS

Model Features	3
Model Number Identification	4
Accessories.....	4
Scroll Compressor	4
Performance Data	5-21
Electrical & Physical Data	22
Unit Dimensions.....	23
Refrigerant Line Size Information	24
Limited Warranty	25



All controls and compressor are accessible for servicing by removal of the service panel.



Drawn Painted Base Pan.

Model Features

RANL- Series Condensing Units

1. This unit contains a special scroll compressor that is designed specifically to operate with R-410A refrigerants and polyolester (POE) oils. The compressor is hermetically sealed and incorporates internal high temperature motor overload protection and durable insulation on the motor windings. It is externally mounted on rubber grommets to reduce vibration and noise.
2. Compressors have an internal pressure relief assembly to protect against excessive pressure differential.
3. All refrigerant connections are on the exterior of the unit, located close to the ground for neat appearing installations.
4. Cabinet is constructed of powder painted galvanized steel. The full wraparound louvered grille protects the coil from damage.
5. Copper tube—aluminum fin coils are used on all models.
6. The control box is located in the top corner of the cabinet providing for easy access through a service panel.
7. Service valves are standard on all models.
8. Power and control wiring are kept separate.
9. Every unit is factory charged and tested.
10. Separate compressor compartment for easy service access.
11. Drawn, painted base pan for extra corrosion resistance and sound reduction.
12. Automatic reset high and low pressure controls are standard on all models.
13. A liquid line filter drier is standard on all models (shipped – not installed).



Model Number Identification

R	A	N	L	—	018	J	A	Z
RHEEM	REMOTE CONDENSING UNIT	N = 13 SEER	DESIGN SERIES L = R-410A		COOLING CAPACITY 018 = 18,000 BTU/HR [5.28 kW] 024 = 24,000 BTU/HR [7.03 kW] 031 = 30,000 BTU/HR [8.79 kW] 037 = 36,000 BTU/HR [10.55 kW] 043 = 42,000 BTU/HR [12.31 kW] 049 = 48,000 BTU/HR [14.07 kW] 060 = 60,000 BTU/HR [17.58 kW]	ELECTRICAL DESIGNATION J = 208/230V-1-60 C = 208/230V-3-60 D = 460V-3-60 (RANL MODELS ONLY) Y = 575V-3-60	VARIATIONS A-SERIES = FULL-FEATURED	COOLING CONNECTION FITTING Z = SWEAT W/SCROLL

Accessories

- Low Ambient Control (RXAD-A08)
- Hard Start Components
- Compressor Time Delay Control (RXMD-B01)
- Crankcase Heater

Thermostats



200-Series *
Programmable



300-Series *
Deluxe
Programmable

400-Series *
Special Applications/
Programmable



500-Series *
Communicating/
Programmable

Brand	Descriptor (3 Characters)	Series (3 Characters)	System (2 Characters)	Type (2 Characters)
RHC	TST	213	UN	MS
RHC=Rheem	TST=Thermostat	200=Programmable 300=Deluxe Programmable 400=Special Applications/ Programmable 500=Communicating/ Programmable	GE=Gas/Electric UN=Universal (AC/HP/GE) MD=Modulating Furnace DF=Dual Fuel CM=Communicating	SS=Single-Stage MS=Multi-Stage

* Photos are representative. Actual models may vary.

For detailed thermostat match-up information,
see specification sheet form number T11-001.

Scroll® Compressor

The reliable scroll compressor is the key to efficiency for this Rheem model. It's the latest in high-efficiency compressor technology. The advanced scroll compressor offers low noise and vibration characteristics and features tolerance to liquid refrigerant and system contamination. The scroll compressor also has low start torque, reducing start problems in the field. And its unique design enables air conditioners to perform efficiently and quietly.

[] Designates Metric Conversions



Performance Data @ AHRI Standard Conditions—Cooling

Model Numbers		80°F [26.5°C] DB/67°F [19.5°C] WB Indoor Air 95°F [35°C] DB Outdoor Air					Sound Rating dB	Indoor CFM [L/s]
Outdoor Unit RANL-	Indoor Coil and/or Air Handler	Total Capacity BTU/H [kW]	Net Sensible BTU/H [kW]	Net Latent BTU/H [kW]	EER	SEER		
Rev. 5/17/12	RCFL-H*2417 ①	18,400 [5.4]	13,200 [3.9]	5,200 [1.5]	11.00	13.00	74	600 [283]
	RHAL-FR24P	19,600 [5.7]	15,150 [4.4]	4,450 [1.3]	11.00	13.00	74	600 [283]
	RHBL-FR24T	19,600 [5.7]	15,150 [4.4]	4,450 [1.3]	12.00	14.50	74	600 [283]
	RCFL-A*2414	18,400 [5.4]	13,200 [3.9]	5,200 [1.5]	11.00	13.25	74	600 [283]
	RCFL-A*2417	18,400 [5.4]	13,200 [3.9]	5,200 [1.5]	11.00	13.25	74	600 [283]
	RCFL-A*2417(RGFE-06?MCK?)	18,800 [5.5]	13,500 [4.0]	5,300 [1.6]	12.50	14.50	74	575 [271]
	RCFL-A*2417(RGFE-07?MCK?)	18,800 [5.5]	13,500 [4.0]	5,300 [1.6]	12.50	14.50	74	600 [283]
	RCFL-A*2417(RGFG-06?MCK?)	18,900 [5.5]	13,500 [4.0]	5,400 [1.6]	12.00	14.50	74	575 [271]
	RCFL-A*2417(RGFG-07?MCK?)	18,600 [5.4]	13,200 [3.9]	5,400 [1.6]	12.00	14.50	74	550 [260]
	RCFL-A*2417(RGGE-06?MCK?)	18,800 [5.5]	13,500 [4.0]	5,300 [1.6]	12.00	14.50	74	625 [295]
	RCFL-A*2417(RGGE-07?MCK?)	18,800 [5.5]	13,500 [4.0]	5,300 [1.6]	12.00	14.50	74	575 [271]
	RCFL-A*2417(RGLE-07?AMK?)	18,800 [5.5]	13,500 [4.0]	5,300 [1.6]	12.00	14.50	74	600 [283]
	RCFL-A*2417(RGLT-07?AMK?)	19,300 [5.7]	14,100 [4.1]	5,200 [1.5]	12.00	14.50	74	675 [319]
	RCFL-A*2417(RGPE-05?BMK?)	18,800 [5.5]	13,500 [4.0]	5,300 [1.6]	12.00	14.50	74	575 [271]
	RCFL-A*2417(RGPT-05?BMK?)	19,100 [5.6]	13,850 [4.1]	5,250 [1.5]	12.00	14.50	74	650 [307]
	RCFL-A*2417(RGPT-07?AMK?)	18,900 [5.5]	13,550 [4.0]	5,350 [1.6]	12.00	14.50	74	625 [295]
	RCFL-A*2417(RGRM-04?MAE?)	18,800 [5.5]	13,500 [4.0]	5,300 [1.6]	12.00	14.50	74	575 [271]
	RCFL-A*2417(RGRM-06?MAE?)	18,900 [5.5]	13,550 [4.0]	5,350 [1.6]	12.00	14.50	74	600 [283]
	RCFL-A*2417(RGRM-07?MAE?)	18,800 [5.5]	13,500 [4.0]	5,300 [1.6]	11.50	14.00	74	625 [295]
	RCFL-A*2417(RGTM-06?MAE?)	18,700 [5.5]	13,400 [3.9]	5,300 [1.6]	12.00	14.50	74	625 [295]
RCFL-A*2417(ROCA-070E03)	18,900 [5.5]	13,550 [4.0]	5,350 [1.6]	12.00	14.50	74	600 [283]	
RCFL-A*2417(ROLA-070E03)	18,800 [5.5]	13,500 [4.0]	5,300 [1.6]	12.00	14.50	74	600 [283]	
018JAZ	RCFL-H*2414	18,400 [5.4]	13,200 [3.9]	5,200 [1.5]	11.00	13.25	74	600 [283]
	RCFL-H*2417(RGFE-06?MCK?)	18,800 [5.5]	13,500 [4.0]	5,300 [1.6]	12.50	14.50	74	575 [271]
	RCFL-H*2417(RGFE-07?MCK?)	18,800 [5.5]	13,500 [4.0]	5,300 [1.6]	12.50	14.50	74	600 [283]
	RCFL-H*2417(RGFG-06?MCK?)	18,900 [5.5]	13,500 [4.0]	5,400 [1.6]	12.00	14.50	74	575 [271]
	RCFL-H*2417(RGFG-07?MCK?)	18,600 [5.4]	13,200 [3.9]	5,400 [1.6]	12.00	14.50	74	550 [260]
	RCFL-H*2417(RGGE-06?MCK?)	18,800 [5.5]	13,500 [4.0]	5,300 [1.6]	12.00	14.50	74	625 [295]
	RCFL-H*2417(RGGE-07?MCK?)	18,800 [5.5]	13,500 [4.0]	5,300 [1.6]	12.00	14.50	74	575 [271]
	RCFL-H*2417(RGJF-06?MCK?)	18,800 [5.5]	13,500 [4.0]	5,300 [1.6]	12.00	14.50	74	625 [295]
	RCFL-H*2417(RGJF-07?MCK?)	18,800 [5.5]	13,500 [4.0]	5,300 [1.6]	12.00	14.50	74	575 [271]
	RCFL-H*2417(RGLE-07?AMK?)	18,800 [5.5]	13,500 [4.0]	5,300 [1.6]	12.00	14.50	74	600 [283]
	RCFL-H*2417(RGLT-07?AMK?)	19,300 [5.7]	14,100 [4.1]	5,200 [1.5]	12.00	14.50	74	675 [319]
	RCFL-H*2417(RGPE-05?BMK?)	18,800 [5.5]	13,500 [4.0]	5,300 [1.6]	12.00	14.50	74	575 [271]
	RCFL-H*2417(RGPT-05?BMK?)	19,100 [5.6]	13,850 [4.1]	5,250 [1.5]	12.00	14.50	74	650 [307]
	RCFL-H*2417(RGPT-07?AMK?)	18,900 [5.5]	13,550 [4.0]	5,350 [1.6]	12.00	14.50	74	625 [295]
	RCFL-H*2417(RGRM-04?MAE?)	18,800 [5.5]	13,500 [4.0]	5,300 [1.6]	12.00	14.50	74	575 [271]
	RCFL-H*2417(RGRM-06?MAE?)	18,900 [5.5]	13,550 [4.0]	5,350 [1.6]	12.00	14.50	74	600 [283]
	RCFL-H*2417(RGRM-07?MAE?)	18,800 [5.5]	13,500 [4.0]	5,300 [1.6]	11.50	14.00	74	625 [295]
	RCFL-H*2417(RGTM-06?MAE?)	18,700 [5.5]	13,400 [3.9]	5,300 [1.6]	12.00	14.50	74	625 [295]
	RCFL-H*2417(ROCA-070E03)	18,900 [5.5]	13,550 [4.0]	5,350 [1.6]	12.00	14.50	74	600 [283]
	RCFL-H*2417(ROLA-070E03)	18,800 [5.5]	13,500 [4.0]	5,300 [1.6]	12.00	14.50	74	600 [283]
	RBHP-17(RCHL-24A2)	18,200 [5.3]	12,650 [3.7]	5,550 [1.6]	11.50	14.00	74	600 [283]
	RCQD-2417(RGFE-06?MCK?)	19,200 [5.6]	14,050 [4.1]	5,150 [1.5]	12.00	14.50	74	575 [271]
	RCQD-2417(RGFE-07?MCK?)	19,200 [5.6]	14,050 [4.1]	5,150 [1.5]	12.00	14.50	74	600 [283]
	RCQD-2417(RGFG-06?MCK?)	19,300 [5.7]	14,150 [4.1]	5,150 [1.5]	12.00	14.50	74	575 [271]
	RCQD-2417(RGFG-07?MCK?)	19,000 [5.6]	13,750 [4.0]	5,250 [1.5]	12.00	14.50	74	550 [260]
	RCQD-2417(RGJF-06?MCK?)	19,200 [5.6]	14,050 [4.1]	5,150 [1.5]	12.00	14.50	74	625 [295]

① Highest sales volume tested combination required by D.O.E. test procedures.

[] Designates Metric Conversions



Performance Data @ AHRI Standard Conditions—Cooling

Model Numbers		80°F [26.5°C] DB/67°F [19.5°C] WB Indoor Air 95°F [35°C] DB Outdoor Air					Sound Rating dB	Indoor CFM [L/s]
Outdoor Unit RANL-	Indoor Coil and/or Air Handler	Total Capacity BTU/H [kW]	Net Sensible BTU/H [kW]	Net Latent BTU/H [kW]	EER	SEER		
Rev. 5/17/12 018JAZ	RCQD-2417(RGJF-07?MCK?)	19,200 [5.6]	14,050 [4.1]	5,150 [1.5]	12.00	14.50	74	575 [271]
	RCQD-2417(RGPE-05?BMK?)	19,200 [5.6]	14,050 [4.1]	5,150 [1.5]	12.00	14.50	74	575 [271]
	RCQD-2417(RGPT-05?BMK?)	19,400 [5.7]	14,400 [4.2]	5,000 [1.5]	12.00	14.50	74	650 [307]
	RCQD-2417(RGPT-07?AMK?)	19,300 [5.7]	14,300 [4.2]	5,000 [1.5]	12.00	14.50	74	625 [295]
	RCQD-2417(ROCA-070E03)	19,200 [5.6]	14,050 [4.1]	5,150 [1.5]	12.00	14.50	74	600 [283]
	RCQD-2417(ROLA-070E03)	19,100 [5.6]	14,000 [4.1]	5,100 [1.5]	12.00	14.50	74	600 [283]
	RHKL-HM2417(RCSL-H*2417)	19,100 [5.6]	13,750 [4.0]	5,350 [1.6]	12.00	14.50	74	650 [307]
	RHLL-HM2417(RCSL-H*2417)	18,800 [5.5]	13,500 [4.0]	5,300 [1.6]	11.50	14.00	74	600 [283]
	RHSL-HM1817(RCSL-H*2417)	18,600 [5.4]	13,300 [3.9]	5,300 [1.6]	11.00	13.00	74	600 [283]
024JAZ	RCFL-H*2417 ①	23,800 [7.0]	16,900 [5.0]	6,900 [2.0]	11.00	13.00	72	800 [378]
	RHAL-FR24P	24,400 [7.1]	18,800 [5.5]	5,600 [1.6]	11.00	13.00	72	800 [378]
	RHBL-FR24T	24,400 [7.1]	18,800 [5.5]	5,600 [1.6]	12.00	14.50	72	800 [378]
	RCFL-A*2414	23,800 [7.0]	16,900 [5.0]	6,900 [2.0]	11.00	13.25	72	800 [378]
	RCFL-A*2417	23,800 [7.0]	16,900 [5.0]	6,900 [2.0]	11.00	13.25	72	800 [378]
	RCFL-A*2417(RGFE-06?MCK?)	24,000 [7.0]	16,750 [4.9]	7,250 [2.1]	11.50	14.00	72	725 [342]
	RCFL-A*2417(RGFE-07?MCK?)	24,000 [7.0]	16,750 [4.9]	7,250 [2.1]	11.50	14.00	72	725 [342]
	RCFL-A*2417(RGFG-06?MCK?)	24,200 [7.1]	17,200 [5.0]	7,000 [2.1]	12.00	14.50	72	800 [378]
	RCFL-A*2417(RGFG-07?MCK?)	24,600 [7.2]	17,500 [5.1]	7,100 [2.1]	12.00	14.50	72	800 [378]
	RCFL-A*2417(RGGE-06?MCK?)	24,400 [7.1]	17,350 [5.1]	7,050 [2.1]	11.50	14.00	72	825 [389]
	RCFL-A*2417(RGGE-07?MCK?)	24,200 [7.1]	17,000 [5.0]	7,200 [2.1]	12.00	14.50	72	750 [354]
	RCFL-A*2417(RGJF-06?MCK?)	24,400 [7.1]	17,350 [5.1]	7,050 [2.1]	11.50	14.00	72	825 [389]
	RCFL-A*2417(RGLE-07?AMK?)	24,400 [7.1]	17,300 [5.1]	7,100 [2.1]	12.00	14.50	72	800 [378]
	RCFL-A*2417(RGLT-07?AMK?)	24,800 [7.3]	17,800 [5.2]	7,000 [2.1]	12.00	14.50	72	850 [401]
	RCFL-A*2417(RGPE-05?BMK?)	24,400 [7.1]	17,350 [5.1]	7,050 [2.1]	12.00	14.50	72	800 [378]
	RCFL-A*2417(RGPE-07?AMK?)	24,000 [7.0]	16,700 [4.9]	7,300 [2.1]	12.00	14.50	72	725 [342]
	RCFL-A*2417(RGPT-05?BMK?)	24,800 [7.3]	17,800 [5.2]	7,000 [2.1]	12.00	14.50	72	850 [401]
	RCFL-A*2417(RGPT-07?AMK?)	24,800 [7.3]	17,800 [5.2]	7,000 [2.1]	12.00	14.50	72	850 [401]
	RCFL-A*2417(RGRM-04?MAE?)	24,400 [7.1]	17,300 [5.1]	7,100 [2.1]	11.50	14.00	72	800 [378]
	RCFL-A*2417(RGRM-06?MAE?)	24,400 [7.1]	17,300 [5.1]	7,100 [2.1]	11.50	14.00	72	825 [389]
	RCFL-A*2417(RGRM-07?MAE?)	24,600 [7.2]	17,650 [5.2]	6,950 [2.0]	11.50	14.00	72	850 [401]
	RCFL-A*2417(RGTM-06?MAE?)	24,400 [7.1]	17,350 [5.1]	7,050 [2.1]	11.50	14.00	72	825 [389]
	RCFL-A*2417(RHWB-04WMMX36A)	24,600 [7.2]	17,700 [5.2]	6,900 [2.0]	11.50	14.00	72	825 [389]
	RCFL-A*2417(ROCA-070E03)	24,600 [7.2]	17,450 [5.1]	7,150 [2.1]	12.00	14.50	72	800 [378]
	RCFL-A*2417(ROCA-070E04)	24,600 [7.2]	17,450 [5.1]	7,150 [2.1]	12.00	14.50	72	800 [378]
	RCFL-A*2417(ROLA-070E03)	24,600 [7.2]	17,450 [5.1]	7,150 [2.1]	12.00	14.50	72	800 [378]
	RCFL-A*2417(ROLA-070E04)	24,200 [7.1]	16,850 [4.9]	7,350 [2.2]	12.00	14.50	72	725 [342]
	RCFL-H*2414	23,800 [7.0]	16,900 [5.0]	6,900 [2.0]	11.00	13.25	72	800 [378]
	RCFL-H*2417(RGFE-06?MCK?)	24,000 [7.0]	16,750 [4.9]	7,250 [2.1]	11.50	14.00	72	725 [342]
	RCFL-H*2417(RGFE-07?MCK?)	24,000 [7.0]	16,750 [4.9]	7,250 [2.1]	11.50	14.00	72	725 [342]
	RCFL-H*2417(RGFG-06?MCK?)	24,200 [7.1]	17,200 [5.0]	7,000 [2.1]	12.00	14.50	72	800 [378]
	RCFL-H*2417(RGFG-07?MCK?)	24,600 [7.2]	17,500 [5.1]	7,100 [2.1]	12.00	14.50	72	800 [378]
	RCFL-H*2417(RGGE-06?MCK?)	24,400 [7.1]	17,350 [5.1]	7,050 [2.1]	11.50	14.00	72	825 [389]
	RCFL-H*2417(RGGE-07?MCK?)	24,200 [7.1]	17,000 [5.0]	7,200 [2.1]	12.00	14.50	72	750 [354]
	RCFL-H*2417(RGJF-06?MCK?)	24,400 [7.1]	17,350 [5.1]	7,050 [2.1]	11.50	14.00	72	825 [389]
	RCFL-H*2417(RGJF-07?MCK?)	24,400 [7.1]	17,350 [5.1]	7,050 [2.1]	11.50	14.00	72	800 [378]
RCFL-H*2417(RGLE-07?AMK?)	24,400 [7.1]	17,300 [5.1]	7,100 [2.1]	12.00	14.50	72	800 [378]	
RCFL-H*2417(RGLT-07?AMK?)	24,800 [7.3]	17,800 [5.2]	7,000 [2.1]	12.00	14.50	72	850 [401]	
RCFL-H*2417(RGPE-05?BMK?)	24,400 [7.1]	17,350 [5.1]	7,050 [2.1]	12.00	14.50	72	800 [378]	

① Highest sales volume tested combination required by D.O.E. test procedures.

[] Designates Metric Conversions



Performance Data @ AHRI Standard Conditions—Cooling

Model Numbers		80°F [26.5°C] DB/67°F [19.5°C] WB Indoor Air 95°F [35°C] DB Outdoor Air					Sound Rating dB	Indoor CFM [L/s]	
Outdoor Unit RANL-	Indoor Coil and/or Air Handler	Total Capacity BTU/H [kW]	Net Sensible BTU/H [kW]	Net Latent BTU/H [kW]	EER	SEER			
Rev. 5/17/12	RCFL-H*2417(RGPE-07?AMK?)	24,000 [7.0]	16,700 [4.9]	7,300 [2.1]	12.00	14.50	72	725 [342]	
	RCFL-H*2417(RGPT-05?BMK?)	24,800 [7.3]	17,800 [5.2]	7,000 [2.1]	12.00	14.50	72	850 [401]	
	RCFL-H*2417(RGPT-07?AMK?)	24,800 [7.3]	17,800 [5.2]	7,000 [2.1]	12.00	14.50	72	850 [401]	
	RCFL-H*2417(RGRM-04?MAE?)	24,400 [7.1]	17,300 [5.1]	7,100 [2.1]	11.50	14.00	72	800 [378]	
	RCFL-H*2417(RGRM-06?MAE?)	24,400 [7.1]	17,300 [5.1]	7,100 [2.1]	11.50	14.00	72	825 [389]	
	RCFL-H*2417(RGRM-07?MAE?)	24,600 [7.2]	17,650 [5.2]	6,950 [2.0]	11.50	14.00	72	850 [401]	
	RCFL-H*2417(RGTM-06?MAE?)	24,400 [7.1]	17,350 [5.1]	7,050 [2.1]	11.50	14.00	72	825 [389]	
	RCFL-H*2417(RHWP-04WMMX36A)	24,600 [7.2]	17,700 [5.2]	6,900 [2.0]	11.50	14.00	72	825 [389]	
	RCFL-H*2417(ROCA-070E03)	24,600 [7.2]	17,450 [5.1]	7,150 [2.1]	12.00	14.50	72	800 [378]	
	RCFL-H*2417(ROCA-070E04)	24,600 [7.2]	17,450 [5.1]	7,150 [2.1]	12.00	14.50	72	800 [378]	
	RCFL-H*2417(ROLA-070E03)	24,600 [7.2]	17,450 [5.1]	7,150 [2.1]	12.00	14.50	72	800 [378]	
	RCFL-H*2417(ROLA-070E04)	24,200 [7.1]	16,850 [4.9]	7,350 [2.2]	12.00	14.50	72	725 [342]	
	RBHP-17(RCHL-24A2)	23,400 [6.9]	16,050 [4.7]	7,350 [2.2]	11.50	14.00	72	800 [378]	
	RCQD-2417(RGFE-06?MCK?)	24,800 [7.3]	17,650 [5.2]	7,150 [2.1]	12.00	14.50	72	725 [342]	
	RCQD-2417(RGFE-07?MCK?)	24,800 [7.3]	17,650 [5.2]	7,150 [2.1]	12.00	14.50	72	725 [342]	
	RCQD-2417(RGFG-06?MCK?)	25,400 [7.4]	18,500 [5.4]	6,900 [2.0]	12.00	14.50	72	800 [378]	
	RCQD-2417(RGFG-07?MCK?)	25,400 [7.4]	18,500 [5.4]	6,900 [2.0]	12.00	14.50	72	800 [378]	
	RCQD-2417(RGGE-06?MCK?)	25,200 [7.4]	18,250 [5.3]	6,950 [2.0]	12.00	14.50	72	825 [389]	
	RCQD-2417(RGJF-06?MCK?)	25,200 [7.4]	18,250 [5.3]	6,950 [2.0]	12.00	14.50	72	825 [389]	
	RCQD-2417(RGJF-07?MCK?)	25,200 [7.4]	18,300 [5.4]	6,900 [2.0]	12.00	14.50	72	800 [378]	
RCQD-2417(RGPE-05?BMK?)	25,200 [7.4]	18,250 [5.3]	6,950 [2.0]	12.00	14.50	72	800 [378]		
RCQD-2417(RGPT-05?BMK?)	25,600 [7.5]	19,000 [5.6]	6,600 [1.9]	12.00	14.50	72	900 [425]		
RCQD-2417(RHWP-04WMMX36A)	25,600 [7.5]	19,200 [5.6]	6,400 [1.9]	11.50	14.00	72	875 [413]		
RCQD-2417(ROCA-070E03)	25,200 [7.4]	18,250 [5.3]	6,950 [2.0]	12.00	14.50	72	800 [378]		
RCQD-2417(ROCA-070E04)	25,200 [7.4]	18,250 [5.3]	6,950 [2.0]	12.00	14.50	72	800 [378]		
RCQD-2417(ROLA-070E03)	25,200 [7.4]	18,250 [5.3]	6,950 [2.0]	12.00	14.50	72	800 [378]		
RCQD-2417(ROLA-070E04)	24,800 [7.3]	17,650 [5.2]	7,150 [2.1]	12.00	14.50	72	725 [342]		
RHKL-HM2417(RCSL-H*2417)	24,800 [7.3]	17,650 [5.2]	7,150 [2.1]	11.50	14.00	72	850 [401]		
RHLL-HM2417(RCSL-H*2417)	24,800 [7.3]	17,600 [5.2]	7,200 [2.1]	12.50	15.00	72	775 [366]		
RHSL-HM2417(RCSL-H*2417)	24,200 [7.1]	17,250 [5.1]	6,950 [2.0]	11.00	13.00	72	800 [378]		
024JAZ	RCFL-H*3617 ①	28,800 [8.4]	21,150 [6.2]	7,650 [2.2]	10.50	13.00	73	1,000 [472]	
	RHAL-FR30P	30,000 [8.8]	23,250 [6.8]	6,750 [2.0]	11.00	13.00	73	1,000 [472]	
	RHBL-FR36T	30,000 [8.8]	23,250 [6.8]	6,750 [2.0]	12.00	14.50	73	1,025 [484]	
	RCFL-A*3617	28,800 [8.4]	21,150 [6.2]	7,650 [2.2]	10.50	13.00	73	1,000 [472]	
	RCFL-A*3617(RGFE-06?MCK?)	29,200 [8.6]	21,450 [6.3]	7,750 [2.3]	11.00	13.50	73	1,000 [472]	
	RCFL-A*3617(RGFE-07?MCK?)	29,000 [8.5]	21,300 [6.2]	7,700 [2.3]	11.00	13.00	73	1,025 [484]	
	RCFL-A*3617(RGFG-06?MCK?)	28,600 [8.4]	20,400 [6.0]	8,200 [2.4]	11.50	13.50	73	875 [413]	
	RCFL-A*3617(RGFG-07?MCK?)	28,600 [8.4]	20,400 [6.0]	8,200 [2.4]	11.50	13.50	73	850 [401]	
	RCFL-A*3617(RGGE-06?MCK?)	30,400 [8.9]	22,350 [6.5]	8,050 [2.4]	11.50	14.00	73	1,025 [484]	
	RCFL-A*3617(RGGE-07?MCK?)	29,200 [8.6]	21,450 [6.3]	7,750 [2.3]	11.00	13.50	73	1,025 [484]	
	RCFL-A*3617(RGJF-06?MCK?)	30,400 [8.9]	22,350 [6.5]	8,050 [2.4]	11.50	14.00	73	1,025 [484]	
	RCFL-A*3617(RGLE-07?AMK?)	30,400 [8.9]	22,300 [6.5]	8,100 [2.4]	11.50	14.00	73	1,025 [484]	
	RCFL-A*3617(RGLT-07?AMK?)	28,800 [8.4]	20,550 [6.0]	8,250 [2.4]	11.50	14.00	73	875 [413]	
	RCFL-A*3617(RGPE-05?BMK?)	29,200 [8.6]	21,450 [6.3]	7,750 [2.3]	11.00	13.50	73	975 [460]	
	RCFL-A*3617(RGPE-07?AMK?)	29,200 [8.6]	21,450 [6.3]	7,750 [2.3]	11.50	13.50	73	1,000 [472]	
	RCFL-A*3617(RGPT-05?BMK?)	28,600 [8.4]	20,250 [5.9]	8,350 [2.4]	11.50	14.00	73	850 [401]	
	RCFL-A*3617(RGPT-07?AMK?)	28,800 [8.4]	20,550 [6.0]	8,250 [2.4]	11.50	14.00	73	875 [413]	
	RCFL-A*3617(RGRM-04?MAE?)	29,000 [8.5]	21,300 [6.2]	7,700 [2.3]	11.00	13.00	73	1,025 [484]	
	031JAZ	RCFL-H*3617 ①	28,800 [8.4]	21,150 [6.2]	7,650 [2.2]	10.50	13.00	73	1,000 [472]
		RHAL-FR30P	30,000 [8.8]	23,250 [6.8]	6,750 [2.0]	11.00	13.00	73	1,000 [472]
RHBL-FR36T		30,000 [8.8]	23,250 [6.8]	6,750 [2.0]	12.00	14.50	73	1,025 [484]	
RCFL-A*3617		28,800 [8.4]	21,150 [6.2]	7,650 [2.2]	10.50	13.00	73	1,000 [472]	
RCFL-A*3617(RGFE-06?MCK?)		29,200 [8.6]	21,450 [6.3]	7,750 [2.3]	11.00	13.50	73	1,000 [472]	
RCFL-A*3617(RGFE-07?MCK?)		29,000 [8.5]	21,300 [6.2]	7,700 [2.3]	11.00	13.00	73	1,025 [484]	
RCFL-A*3617(RGFG-06?MCK?)		28,600 [8.4]	20,400 [6.0]	8,200 [2.4]	11.50	13.50	73	875 [413]	
RCFL-A*3617(RGFG-07?MCK?)		28,600 [8.4]	20,400 [6.0]	8,200 [2.4]	11.50	13.50	73	850 [401]	
RCFL-A*3617(RGGE-06?MCK?)		30,400 [8.9]	22,350 [6.5]	8,050 [2.4]	11.50	14.00	73	1,025 [484]	
RCFL-A*3617(RGGE-07?MCK?)		29,200 [8.6]	21,450 [6.3]	7,750 [2.3]	11.00	13.50	73	1,025 [484]	
RCFL-A*3617(RGJF-06?MCK?)		30,400 [8.9]	22,350 [6.5]	8,050 [2.4]	11.50	14.00	73	1,025 [484]	
RCFL-A*3617(RGLE-07?AMK?)		30,400 [8.9]	22,300 [6.5]	8,100 [2.4]	11.50	14.00	73	1,025 [484]	
RCFL-A*3617(RGLT-07?AMK?)		28,800 [8.4]	20,550 [6.0]	8,250 [2.4]	11.50	14.00	73	875 [413]	
RCFL-A*3617(RGPE-05?BMK?)		29,200 [8.6]	21,450 [6.3]	7,750 [2.3]	11.00	13.50	73	975 [460]	
RCFL-A*3617(RGPE-07?AMK?)		29,200 [8.6]	21,450 [6.3]	7,750 [2.3]	11.50	13.50	73	1,000 [472]	
RCFL-A*3617(RGPT-05?BMK?)		28,600 [8.4]	20,250 [5.9]	8,350 [2.4]	11.50	14.00	73	850 [401]	
RCFL-A*3617(RGPT-07?AMK?)		28,800 [8.4]	20,550 [6.0]	8,250 [2.4]	11.50	14.00	73	875 [413]	
RCFL-A*3617(RGRM-04?MAE?)		29,000 [8.5]	21,300 [6.2]	7,700 [2.3]	11.00	13.00	73	1,025 [484]	

① Highest sales volume tested combination required by D.O.E. test procedures.

[] Designates Metric Conversions



Performance Data @ AHRI Standard Conditions—Cooling

Model Numbers		80°F [26.5°C] DB/67°F [19.5°C] WB Indoor Air 95°F [35°C] DB Outdoor Air					Sound Rating dB	Indoor CFM [L/s]
Outdoor Unit RANL-	Indoor Coil and/or Air Handler	Total Capacity BTU/H [kW]	Net Sensible BTU/H [kW]	Net Latent BTU/H [kW]	EER	SEER		
Rev. 5/17/12	RCFL-A*3617(RGRM-06?MAE?)	29,000 [8.5]	21,300 [6.2]	7,700 [2.3]	11.00	13.50	73	1,000 [472]
	RCFL-A*3617(RGRM-07?MAE?)	28,400 [8.3]	20,100 [5.9]	8,300 [2.4]	11.00	13.50	73	850 [401]
	RCFL-A*3617(RGRM-07?YBG?)	29,000 [8.5]	21,300 [6.2]	7,700 [2.3]	11.00	13.00	73	975 [460]
	RCFL-A*3617(RGTM-06?MAE?)	30,000 [8.8]	21,500 [6.3]	8,500 [2.5]	11.50	14.00	73	900 [425]
	RCFL-A*3617(RHWB-04WMX36A)	29,200 [8.6]	21,600 [6.3]	7,600 [2.2]	11.50	14.00	73	1,025 [484]
	RCFL-A*3617(RHWB-06WMX48A)	29,200 [8.6]	21,400 [6.3]	7,800 [2.3]	11.50	14.00	73	950 [448]
	RCFL-A*3617(ROCA-070E03)	29,200 [8.6]	21,400 [6.3]	7,800 [2.3]	11.50	13.50	73	1,000 [472]
	RCFL-A*3617(ROCA-070E04)	29,200 [8.6]	21,400 [6.3]	7,800 [2.3]	11.50	13.50	73	1,000 [472]
	RCFL-A*3617(ROLA-070E03)	29,400 [8.6]	21,600 [6.3]	7,800 [2.3]	11.50	14.00	73	975 [460]
	RCFL-A*3617(ROLA-070E04)	29,400 [8.6]	21,600 [6.3]	7,800 [2.3]	11.50	14.00	73	975 [460]
	RCFL-A*3621	28,800 [8.4]	21,150 [6.2]	7,650 [2.2]	10.50	13.00	73	1,000 [472]
	RCFL-A*3621(RGFE-06?MCK?)	30,400 [8.9]	22,350 [6.5]	8,050 [2.4]	11.50	13.50	73	1,000 [472]
	RCFL-A*3621(RGFE-07?MCK?)	30,200 [8.8]	22,150 [6.5]	8,050 [2.4]	11.50	13.50	73	1,025 [484]
	RCFL-A*3621(RGFE-09?ZCM?)	30,600 [9.0]	22,500 [6.6]	8,100 [2.4]	11.50	14.00	73	975 [460]
	RCFL-A*3621(RGFE-10?ZCM?)	30,600 [9.0]	22,500 [6.6]	8,100 [2.4]	11.50	14.00	73	1,000 [472]
	RCFL-A*3621(RGFG-06?MCK?)	28,600 [8.4]	20,400 [6.0]	8,200 [2.4]	11.50	13.50	73	875 [413]
	RCFL-A*3621(RGFG-07?MCK?)	28,600 [8.4]	20,400 [6.0]	8,200 [2.4]	11.50	14.00	73	850 [401]
	RCFL-A*3621(RGFG-09?ZCM?)	29,000 [8.5]	20,600 [6.0]	8,400 [2.5]	12.00	14.00	73	875 [413]
	RCFL-A*3621(RGFG-10?ZCM?)	29,000 [8.5]	20,800 [6.1]	8,200 [2.4]	11.50	14.00	73	900 [425]
	RCFL-A*3621(RGGE-06?MCK?)	30,400 [8.9]	22,350 [6.5]	8,050 [2.4]	11.50	14.00	73	1,025 [484]
	RCFL-A*3621(RGGE-07?MCK?)	30,400 [8.9]	22,350 [6.5]	8,050 [2.4]	11.50	14.00	73	1,025 [484]
	RCFL-A*3621(RGGE-09?ZCM?)	30,600 [9.0]	22,500 [6.6]	8,100 [2.4]	11.50	14.00	73	1,000 [472]
	RCFL-A*3621(RGGE-10?ZCM?)	30,800 [9.0]	22,900 [6.7]	7,900 [2.3]	11.50	14.00	73	1,050 [495]
	RCFL-A*3621(RGJF-06?MCK?)	30,400 [8.9]	22,350 [6.5]	8,050 [2.4]	11.50	14.00	73	1,025 [484]
	RCFL-A*3621(RGLE-07?AMK?)	30,400 [8.9]	22,300 [6.5]	8,100 [2.4]	11.50	14.00	73	1,025 [484]
	RCFL-A*3621(RGLE-07?BRQ?)	30,600 [9.0]	22,450 [6.6]	8,150 [2.4]	12.00	14.50	73	1,025 [484]
	RCFL-A*3621(RGLE-10?BRM?)	31,000 [9.1]	23,050 [6.8]	7,950 [2.3]	12.00	14.50	73	1,050 [495]
	RCFL-A*3621(RGLT-07?AMK?)	28,800 [8.4]	20,550 [6.0]	8,250 [2.4]	11.50	14.00	73	875 [413]
	RCFL-A*3621(RGLT-07?BRQ?)	29,600 [8.7]	21,750 [6.4]	7,850 [2.3]	11.50	14.00	73	975 [460]
	RCFL-A*3621(RGLT-10?BRM?)	29,600 [8.7]	21,750 [6.4]	7,850 [2.3]	12.00	14.50	73	975 [460]
	RCFL-A*3621(RGPE-05?BMK?)	30,400 [8.9]	22,300 [6.5]	8,100 [2.4]	11.50	14.00	73	975 [460]
	RCFL-A*3621(RGPE-07?AMK?)	30,400 [8.9]	22,300 [6.5]	8,100 [2.4]	11.50	14.00	73	1,000 [472]
	RCFL-A*3621(RGPE-07?BRQ?)	30,800 [9.0]	22,850 [6.7]	7,950 [2.3]	12.00	14.50	73	1,050 [495]
	RCFL-A*3621(RGPE-10?BRM?)	30,200 [8.8]	21,650 [6.3]	8,550 [2.5]	12.00	14.50	73	900 [425]
	RCFL-A*3621(RGPT-05?BMK?)	28,800 [8.4]	20,550 [6.0]	8,250 [2.4]	11.50	14.00	73	875 [413]
	RCFL-A*3621(RGPT-07?AMK?)	28,800 [8.4]	20,550 [6.0]	8,250 [2.4]	11.50	14.00	73	875 [413]
	RCFL-A*3621(RGPT-07?BRQ?)	29,600 [8.7]	21,750 [6.4]	7,850 [2.3]	12.00	14.50	73	975 [460]
	RCFL-A*3621(RGPT-10?BRM?)	29,600 [8.7]	21,750 [6.4]	7,850 [2.3]	12.00	14.50	73	975 [460]
	RCFL-A*3621(RGRM-04?MAE?)	29,000 [8.5]	21,300 [6.2]	7,700 [2.3]	11.00	13.00	73	1,025 [484]
	RCFL-A*3621(RGRM-06?MAE?)	29,000 [8.5]	21,250 [6.2]	7,750 [2.3]	11.00	13.50	73	1,000 [472]
RCFL-A*3621(RGRM-07?MAE?)	28,800 [8.4]	21,150 [6.2]	7,650 [2.2]	11.00	13.00	73	1,025 [484]	
RCFL-A*3621(RGRM-07?YBG?)	29,000 [8.5]	21,300 [6.2]	7,700 [2.3]	11.00	13.00	73	975 [460]	
RCFL-A*3621(RGTM-06?MAE?)	30,000 [8.8]	21,500 [6.3]	8,500 [2.5]	11.50	14.00	73	900 [425]	
RCFL-A*3621(RGTM-07?RBG?)	31,000 [9.1]	23,400 [6.9]	7,600 [2.2]	11.50	14.00	73	1,125 [531]	
RCFL-A*3621(RGTM-09?ZAJ?)	30,600 [9.0]	22,450 [6.6]	8,150 [2.4]	12.00	14.50	73	975 [460]	
RCFL-A*3621(RHWB-04WMX36A)	29,200 [8.6]	21,600 [6.3]	7,600 [2.2]	11.50	14.00	73	1,025 [484]	
RCFL-A*3621(RHWB-06WMX48A)	29,400 [8.6]	21,800 [6.4]	7,600 [2.2]	11.50	14.00	73	975 [460]	
RCFL-A*3621(ROCA-070E03)	29,400 [8.6]	21,600 [6.3]	7,800 [2.3]	11.50	14.00	73	1,000 [472]	

① Highest sales volume tested combination required by D.O.E. test procedures.

[] Designates Metric Conversions

Performance Data @ AHRI Standard Conditions—Cooling

Model Numbers		80°F [26.5°C] DB/67°F [19.5°C] WB Indoor Air 95°F [35°C] DB Outdoor Air					Sound Rating dB	Indoor CFM [L/s]
Outdoor Unit RANL-	Indoor Coil and/or Air Handler	Total Capacity BTU/H [kW]	Net Sensible BTU/H [kW]	Net Latent BTU/H [kW]	EER	SEER		
Rev. 5/17/12	RCFL-A*3621(ROCA-070E04)	29,400 [8.6]	21,600 [6.3]	7,800 [2.3]	11.50	14.00	73	1,000 [472]
	RCFL-A*3621(ROLA-070E03)	29,400 [8.6]	21,600 [6.3]	7,800 [2.3]	11.50	14.00	73	975 [460]
	RCFL-A*3621(ROLA-070E04)	29,400 [8.6]	21,600 [6.3]	7,800 [2.3]	11.50	14.00	73	1,025 [484]
	RCFL-A*3621(ROLA-115E05)	29,000 [8.5]	20,800 [6.1]	8,200 [2.4]	11.50	14.00	73	900 [425]
	RCFL-H*3617(RGFE-06?MCK?)	30,200 [8.8]	22,150 [6.5]	8,050 [2.4]	11.50	13.50	73	1,000 [472]
	RCFL-H*3617(RGFE-07?MCK?)	30,200 [8.8]	22,150 [6.5]	8,050 [2.4]	11.00	13.50	73	1,025 [484]
	RCFL-H*3617(RGFG-06?MCK?)	28,600 [8.4]	20,400 [6.0]	8,200 [2.4]	11.50	13.50	73	875 [413]
	RCFL-H*3617(RGFG-07?MCK?)	28,600 [8.4]	20,400 [6.0]	8,200 [2.4]	11.50	13.50	73	850 [401]
	RCFL-H*3617(RGGE-06?MCK?)	30,400 [8.9]	22,350 [6.5]	8,050 [2.4]	11.50	14.00	73	1,025 [484]
	RCFL-H*3617(RGGE-07?MCK?)	30,400 [8.9]	22,350 [6.5]	8,050 [2.4]	11.50	13.50	73	1,025 [484]
031JAZ	RCFL-H*3617(RGJF-06?MCK?)	30,400 [8.9]	22,350 [6.5]	8,050 [2.4]	11.50	14.00	73	1,025 [484]
	RCFL-H*3617(RGJF-07?MCK?)	29,800 [8.7]	21,250 [6.2]	8,550 [2.5]	11.50	14.00	73	875 [413]
	RCFL-H*3617(RGLE-07?AMK?)	30,400 [8.9]	22,300 [6.5]	8,100 [2.4]	11.50	14.00	73	1,025 [484]
	RCFL-H*3617(RGLT-07?AMK?)	28,800 [8.4]	20,550 [6.0]	8,250 [2.4]	11.50	14.00	73	875 [413]
	RCFL-H*3617(RGPE-05?BMK?)	30,400 [8.9]	22,300 [6.5]	8,100 [2.4]	11.50	14.00	73	975 [460]
	RCFL-H*3617(RGPE-07?AMK?)	30,400 [8.9]	22,300 [6.5]	8,100 [2.4]	11.50	14.00	73	1,000 [472]
	RCFL-H*3617(RGPT-05?BMK?)	28,600 [8.4]	20,250 [5.9]	8,350 [2.4]	11.50	14.00	73	850 [401]
	RCFL-H*3617(RGPT-07?AMK?)	28,800 [8.4]	20,550 [6.0]	8,250 [2.4]	11.50	14.00	73	875 [413]
	RCFL-H*3617(RGRM-04?MAE?)	29,000 [8.5]	21,300 [6.2]	7,700 [2.3]	11.00	13.00	73	1,025 [484]
	RCFL-H*3617(RGRM-06?MAE?)	29,000 [8.5]	21,300 [6.2]	7,700 [2.3]	11.00	13.50	73	1,000 [472]
	RCFL-H*3617(RGRM-07?MAE?)	28,400 [8.3]	20,100 [5.9]	8,300 [2.4]	11.00	13.50	73	850 [401]
	RCFL-H*3617(RGRM-07?YBG?)	29,000 [8.5]	21,300 [6.2]	7,700 [2.3]	11.00	13.00	73	975 [460]
	RCFL-H*3617(RGTM-06?MAE?)	30,000 [8.8]	21,500 [6.3]	8,500 [2.5]	11.50	14.00	73	900 [425]
	RCFL-H*3617(RHWB-04WMX36A)	29,200 [8.6]	21,600 [6.3]	7,600 [2.2]	11.50	14.00	73	1,025 [484]
	RCFL-H*3617(RHWB-06WMX48A)	29,200 [8.6]	21,400 [6.3]	7,800 [2.3]	11.50	14.00	73	950 [448]
	RCFL-H*3617(ROCA-070E03)	29,200 [8.6]	21,400 [6.3]	7,800 [2.3]	11.50	13.50	73	1,000 [472]
	RCFL-H*3617(ROCA-070E04)	29,200 [8.6]	21,400 [6.3]	7,800 [2.3]	11.50	13.50	73	1,000 [472]
	RCFL-H*3617(ROLA-070E03)	29,400 [8.6]	21,600 [6.3]	7,800 [2.3]	11.50	14.00	73	975 [460]
	RCFL-H*3617(ROLA-070E04)	29,400 [8.6]	21,600 [6.3]	7,800 [2.3]	11.50	14.00	73	975 [460]
	RCFL-H*3621	28,800 [8.4]	21,150 [6.2]	7,650 [2.2]	10.50	13.00	73	1,000 [472]
	RCFL-H*3621(RGFE-06?MCK?)	30,400 [8.9]	22,350 [6.5]	8,050 [2.4]	11.50	13.50	73	1,000 [472]
	RCFL-H*3621(RGFE-07?MCK?)	30,200 [8.8]	22,150 [6.5]	8,050 [2.4]	11.50	13.50	73	1,025 [484]
	RCFL-H*3621(RGFE-09?ZCM?)	30,600 [9.0]	22,500 [6.6]	8,100 [2.4]	11.50	14.00	73	975 [460]
	RCFL-H*3621(RGFE-10?ZCM?)	30,600 [9.0]	22,500 [6.6]	8,100 [2.4]	11.50	14.00	73	1,000 [472]
	RCFL-H*3621(RGFG-06?MCK?)	28,600 [8.4]	20,400 [6.0]	8,200 [2.4]	11.50	13.50	73	875 [413]
	RCFL-H*3621(RGFG-07?MCK?)	28,600 [8.4]	20,400 [6.0]	8,200 [2.4]	11.50	14.00	73	850 [401]
	RCFL-H*3621(RGFG-09?ZCM?)	29,000 [8.5]	20,600 [6.0]	8,400 [2.5]	12.00	14.00	73	875 [413]
	RCFL-H*3621(RGFG-10?ZCM?)	29,000 [8.5]	20,800 [6.1]	8,200 [2.4]	11.50	14.00	73	900 [425]
	RCFL-H*3621(RGGE-06?MCK?)	30,400 [8.9]	22,350 [6.5]	8,050 [2.4]	11.50	14.00	73	1,025 [484]
	RCFL-H*3621(RGJF-06?MCK?)	30,400 [8.9]	22,350 [6.5]	8,050 [2.4]	11.50	14.00	73	1,025 [484]
	RCFL-H*3621(RGJF-07?MCK?)	30,400 [8.9]	22,350 [6.5]	8,050 [2.4]	11.50	14.00	73	1,025 [484]
	RCFL-H*3621(RGJF-09?ZCM?)	30,400 [8.9]	22,300 [6.5]	8,100 [2.4]	11.50	14.00	73	1,025 [484]
	RCFL-H*3621(RGJF-10?ZCM?)	30,800 [9.0]	22,900 [6.7]	7,900 [2.3]	11.50	14.00	73	1,050 [495]
	RCFL-H*3621(RGLE-07?AMK?)	30,400 [8.9]	22,300 [6.5]	8,100 [2.4]	11.50	14.00	73	1,025 [484]
	RCFL-H*3621(RGLE-07?BRQ?)	30,600 [9.0]	22,450 [6.6]	8,150 [2.4]	12.00	14.50	73	1,025 [484]
	RCFL-H*3621(RGLE-10?BRM?)	31,000 [9.1]	23,050 [6.8]	7,950 [2.3]	12.00	14.50	73	1,050 [495]
RCFL-H*3621(RGLT-07?AMK?)	28,800 [8.4]	20,550 [6.0]	8,250 [2.4]	11.50	14.00	73	875 [413]	
RCFL-H*3621(RGLT-07?BRQ?)	29,600 [8.7]	21,750 [6.4]	7,850 [2.3]	11.50	14.00	73	975 [460]	

① Highest sales volume tested combination required by D.O.E. test procedures.

[] Designates Metric Conversions



Performance Data @ AHRI Standard Conditions—Cooling

Model Numbers		80°F [26.5°C] DB/67°F [19.5°C] WB Indoor Air 95°F [35°C] DB Outdoor Air					Sound Rating dB	Indoor CFM [L/s]
Outdoor Unit RANL-	Indoor Coil and/or Air Handler	Total Capacity BTU/H [kW]	Net Sensible BTU/H [kW]	Net Latent BTU/H [kW]	EER	SEER		
Rev. 5/17/12	RCFL-H*3621(RGLT-10?BRM?)	29,600 [8.7]	21,750 [6.4]	7,850 [2.3]	12.00	14.50	73	975 [460]
	RCFL-H*3621(RGPE-05?BMK?)	30,400 [8.9]	22,300 [6.5]	8,100 [2.4]	11.50	14.00	73	975 [460]
	RCFL-H*3621(RGPE-07?AMK?)	30,400 [8.9]	22,300 [6.5]	8,100 [2.4]	11.50	14.00	73	1,000 [472]
	RCFL-H*3621(RGPE-07?BRQ?)	30,800 [9.0]	22,850 [6.7]	7,950 [2.3]	12.00	14.50	73	1,050 [495]
	RCFL-H*3621(RGPE-10?BRM?)	31,000 [9.1]	23,150 [6.8]	7,850 [2.3]	12.00	14.50	73	1,075 [507]
	RCFL-H*3621(RGPT-05?BMK?)	28,800 [8.4]	20,550 [6.0]	8,250 [2.4]	11.50	14.00	73	875 [413]
	RCFL-H*3621(RGPT-07?AMK?)	28,800 [8.4]	20,550 [6.0]	8,250 [2.4]	11.50	14.00	73	875 [413]
	RCFL-H*3621(RGPT-07?BRQ?)	29,600 [8.7]	21,750 [6.4]	7,850 [2.3]	12.00	14.50	73	975 [460]
	RCFL-H*3621(RGPT-10?BRM?)	29,600 [8.7]	21,750 [6.4]	7,850 [2.3]	12.00	14.50	73	975 [460]
	RCFL-H*3621(RGRM-04?MAE?)	29,000 [8.5]	21,300 [6.2]	7,700 [2.3]	11.00	13.00	73	1,025 [484]
	RCFL-H*3621(RGRM-06?MAE?)	29,000 [8.5]	21,250 [6.2]	7,750 [2.3]	11.00	13.50	73	1,000 [472]
	RCFL-H*3621(RGRM-07?MAE?)	28,800 [8.4]	21,150 [6.2]	7,650 [2.2]	11.00	13.00	73	1,025 [484]
	RCFL-H*3621(RGRM-07?YBG?)	29,000 [8.5]	21,300 [6.2]	7,700 [2.3]	11.00	13.00	73	975 [460]
	RCFL-H*3621(RGTM-06?MAE?)	30,000 [8.8]	21,500 [6.3]	8,500 [2.5]	11.50	14.00	73	900 [425]
	RCFL-H*3621(RGTM-07?RBG?)	31,000 [9.1]	23,400 [6.9]	7,600 [2.2]	11.50	14.00	73	1,125 [531]
	RCFL-H*3621(RGTM-09?ZAJ?)	30,600 [9.0]	22,450 [6.6]	8,150 [2.4]	12.00	14.50	73	975 [460]
	031JAZ	RCFL-H*3621(RHWB-04WMX36A)	29,200 [8.6]	21,600 [6.3]	7,600 [2.2]	11.50	14.00	73
RCFL-H*3621(RHWB-06WMX48A)		29,400 [8.6]	21,800 [6.4]	7,600 [2.2]	11.50	14.00	73	975 [460]
RCFL-H*3621(ROCA-070E03)		29,400 [8.6]	21,600 [6.3]	7,800 [2.3]	11.50	14.00	73	1,000 [472]
RCFL-H*3621(ROCA-070E04)		29,400 [8.6]	21,600 [6.3]	7,800 [2.3]	11.50	14.00	73	1,000 [472]
RCFL-H*3621(ROLA-070E03)		29,400 [8.6]	21,600 [6.3]	7,800 [2.3]	11.50	14.00	73	975 [460]
RCFL-H*3621(ROLA-070E04)		29,400 [8.6]	21,600 [6.3]	7,800 [2.3]	11.50	14.00	73	1,025 [484]
RCFL-H*3621(ROLA-115E05)		29,000 [8.5]	20,800 [6.1]	8,200 [2.4]	11.50	14.00	73	900 [425]
RBHP-21(RCHL-36A1)		29,200 [8.6]	20,600 [6.0]	8,600 [2.5]	11.50	14.00	73	1,000 [472]
RCQD-3621(RGFE-06?MCK?)		30,600 [9.0]	22,800 [6.7]	7,800 [2.3]	11.50	14.00	73	1,000 [472]
RCQD-3621(RGFE-07?MCK?)		30,600 [9.0]	22,800 [6.7]	7,800 [2.3]	11.50	14.00	73	1,025 [484]
RCQD-3621(RGFE-09?ZCM?)		30,800 [9.0]	22,950 [6.7]	7,850 [2.3]	12.00	14.50	73	975 [460]
RCQD-3621(RGFE-10?ZCM?)		30,800 [9.0]	23,000 [6.7]	7,800 [2.3]	11.50	14.00	73	1,025 [484]
RCQD-3621(RGFG-06?MCK?)		28,800 [8.4]	20,850 [6.1]	7,950 [2.3]	11.50	14.00	73	875 [413]
RCQD-3621(RGFG-07?MCK?)		28,800 [8.4]	20,750 [6.1]	8,050 [2.4]	11.50	14.00	73	850 [401]
RCQD-3621(RGFG-09?ZCM?)		29,000 [8.5]	21,050 [6.2]	7,950 [2.3]	12.00	14.00	73	875 [413]
RCQD-3621(RGFG-10?ZCM?)		29,200 [8.6]	21,300 [6.2]	7,900 [2.3]	12.00	14.00	73	900 [425]
RCQD-3621(RGGE-06?MCK?)		30,400 [8.9]	22,250 [6.5]	8,150 [2.4]	12.00	14.50	73	925 [437]
RCQD-3621(RGJF-06?MCK?)		30,600 [9.0]	22,800 [6.7]	7,800 [2.3]	11.50	14.00	73	1,025 [484]
RCQD-3621(RGJF-07?MCK?)		30,600 [9.0]	22,800 [6.7]	7,800 [2.3]	11.50	14.00	73	1,025 [484]
RCQD-3621(RGJF-09?ZCM?)		30,800 [9.0]	22,950 [6.7]	7,850 [2.3]	12.00	14.50	73	1,025 [484]
RCQD-3621(RGJF-10?ZCM?)		31,000 [9.1]	23,350 [6.8]	7,650 [2.2]	12.00	14.50	73	1,050 [495]
RCQD-3621(RGPE-05?BMK?)		30,200 [8.8]	22,000 [6.4]	8,200 [2.4]	12.00	14.50	73	900 [425]
RCQD-3621(RGPE-07?AMK?)		30,800 [9.0]	22,950 [6.7]	7,850 [2.3]	12.00	14.50	73	1,000 [472]
RCQD-3621(RGPE-07?BRQ?)		31,200 [9.1]	23,550 [6.9]	7,650 [2.2]	12.00	14.50	73	1,050 [495]
RCQD-3621(RGPE-10?BRM?)		31,200 [9.1]	23,600 [6.9]	7,600 [2.2]	12.00	14.50	73	1,075 [507]
RCQD-3621(RGPT-05?BMK?)		30,200 [8.8]	22,000 [6.4]	8,200 [2.4]	12.00	14.50	73	900 [425]
RCQD-3621(RGPT-07?AMK?)		30,400 [8.9]	22,250 [6.5]	8,150 [2.4]	12.00	14.50	73	925 [437]
RCQD-3621(RGPT-07?BRQ?)		31,200 [9.1]	23,500 [6.9]	7,700 [2.3]	12.00	14.50	73	1,050 [495]
RCQD-3621(RGPT-10?BRM?)		31,200 [9.1]	23,500 [6.9]	7,700 [2.3]	12.00	14.50	73	1,050 [495]
RCQD-3621(RHWB-04WMX36A)		30,000 [8.8]	22,900 [6.7]	7,100 [2.1]	11.50	14.00	73	1,075 [507]
RCQD-3621(RHWB-06WMX48A)		29,600 [8.7]	22,300 [6.5]	7,300 [2.1]	12.00	14.50	73	1,000 [472]
RCQD-3621(ROCA-070E03)		30,800 [9.0]	22,950 [6.7]	7,850 [2.3]	12.00	14.50	73	1,000 [472]

① Highest sales volume tested combination required by D.O.E. test procedures.

[] Designates Metric Conversions

Performance Data @ AHRI Standard Conditions—Cooling

Model Numbers		80°F [26.5°C] DB/67°F [19.5°C] WB Indoor Air 95°F [35°C] DB Outdoor Air					Sound Rating dB	Indoor CFM [L/s]	
Outdoor Unit RANL-	Indoor Coil and/or Air Handler	Total Capacity BTU/H [kW]	Net Sensible BTU/H [kW]	Net Latent BTU/H [kW]	EER	SEER			
Rev. 5/17/12	RCQD-3621(ROCA-070E04)	30,800 [9.0]	22,950 [6.7]	7,850 [2.3]	12.00	14.50	73	1,000 [472]	
	RCQD-3621(ROLA-070E03)	30,800 [9.0]	22,950 [6.7]	7,850 [2.3]	12.00	14.50	73	975 [460]	
	RCQD-3621(ROLA-070E04)	30,800 [9.0]	22,950 [6.7]	7,850 [2.3]	12.00	14.50	73	975 [460]	
	RCQD-3621(ROLA-115E05)	30,400 [8.9]	22,150 [6.5]	8,250 [2.4]	12.00	14.50	73	900 [425]	
	RCQD-3624(RGFG-09?ZCM?)	29,000 [8.5]	21,050 [6.2]	7,950 [2.3]	12.00	14.00	73	875 [413]	
031JAZ	RCQD-3624(RGFG-10?ZCM?)	29,200 [8.6]	21,300 [6.2]	7,900 [2.3]	12.00	14.00	73	900 [425]	
	RCQD-3624(RGFG-12?RCM?)	29,200 [8.6]	21,200 [6.2]	8,000 [2.3]	12.00	14.50	73	875 [413]	
	RCQD-3624(RGPT-07?BRQ?)	31,200 [9.1]	23,500 [6.9]	7,700 [2.3]	12.00	14.50	73	1,050 [495]	
	RCQD-3624(RGPT-10?BRM?)	31,400 [9.2]	23,800 [7.0]	7,600 [2.2]	12.00	14.50	73	1,075 [507]	
	RCQD-3624(RGPT-12?ARM?)	31,000 [9.1]	23,100 [6.8]	7,900 [2.3]	12.00	14.50	73	975 [460]	
	RCQD-3624(ROCA-070E03)	30,800 [9.0]	22,950 [6.7]	7,850 [2.3]	12.00	14.50	73	1,000 [472]	
	RCQD-3624(ROCA-070E04)	30,800 [9.0]	22,950 [6.7]	7,850 [2.3]	12.00	14.50	73	1,000 [472]	
	RCQD-3624(ROLA-070E03)	30,800 [9.0]	22,950 [6.7]	7,850 [2.3]	12.00	14.50	73	975 [460]	
	RCQD-3624(ROLA-070E04)	30,800 [9.0]	22,950 [6.7]	7,850 [2.3]	12.00	14.50	73	1,025 [484]	
	RCQD-3624(ROLA-115E05)	30,400 [8.9]	22,150 [6.5]	8,250 [2.4]	12.00	14.50	73	900 [425]	
	RHKL-HM3617(RCSL-H*3617)	29,400 [8.6]	21,600 [6.3]	7,800 [2.3]	11.50	14.00	73	1,025 [484]	
	RHLL-HM3617(RCSL-H*3617)	29,400 [8.6]	21,550 [6.3]	7,850 [2.3]	11.50	14.00	73	1,000 [472]	
	RHSL-HM3017(RCSL-H*3617)	28,800 [8.4]	20,900 [6.1]	7,900 [2.3]	11.00	13.00	73	950 [448]	
	037CAZ/ DAZ/JAZ	RCFL-H*3617 ①	37,600 [11.0]	25,750 [7.5]	11,850 [3.5]	11.00	13.00	76	1,050 [495]
		RHAL-FR36P	38,000 [11.1]	27,900 [8.2]	10,100 [3.0]	11.00	13.00	76	1,175 [554]
RHAL-FR36T		38,000 [11.1]	27,900 [8.2]	10,100 [3.0]	11.00	13.00	76	1,175 [554]	
RHBL-FR36T		38,000 [11.1]	27,900 [8.2]	10,100 [3.0]	11.50	14.00	76	1,150 [543]	
RCFL-A*3617		37,600 [11.0]	25,750 [7.5]	11,850 [3.5]	11.00	13.00	76	1,050 [495]	
RCFL-A*3617(RGFE-07?MCK?)		37,800 [11.1]	25,900 [7.6]	11,900 [3.5]	11.50	13.50	76	1,025 [484]	
RCFL-A*3617(RGFG-07?MCK?)		37,800 [11.1]	25,800 [7.6]	12,000 [3.5]	11.00	13.00	76	1,050 [495]	
RCFL-A*3617(RGGE-06?MCK?)		38,000 [11.1]	26,050 [7.6]	11,950 [3.5]	11.50	13.50	76	1,025 [484]	
RCFL-A*3617(RGGE-07?MCK?)		38,000 [11.1]	26,050 [7.6]	11,950 [3.5]	11.50	13.50	76	1,025 [484]	
RCFL-A*3617(RGJF-06?MCK?)		38,500 [11.3]	28,000 [8.2]	10,500 [3.1]	11.00	13.50	76	1,200 [566]	
RCFL-A*3617(RGLE-07?AMK?)		38,500 [11.3]	27,950 [8.2]	10,550 [3.1]	11.50	13.50	76	1,200 [566]	
RCFL-A*3617(RGLT-07?AMK?)		38,500 [11.3]	27,100 [7.9]	11,400 [3.3]	11.00	13.00	76	1,150 [543]	
RCFL-A*3617(RGPE-05?BMK?)		38,500 [11.3]	27,350 [8.0]	11,150 [3.3]	11.00	13.00	76	1,200 [566]	
RCFL-A*3617(RGPE-07?AMK?)		38,500 [11.3]	27,450 [8.0]	11,050 [3.2]	11.00	13.00	76	1,225 [578]	
RCFL-A*3617(RGPT-05?BMK?)		38,000 [11.1]	26,700 [7.8]	11,300 [3.3]	11.00	13.00	76	1,175 [554]	
RCFL-A*3617(RGPT-07?AMK?)		38,500 [11.3]	27,200 [8.0]	11,300 [3.3]	11.00	13.00	76	1,175 [554]	
RCFL-A*3617(RGRM-04?MAE?)		37,800 [11.1]	25,900 [7.6]	11,900 [3.5]	11.00	13.00	76	1,025 [484]	
RCFL-A*3617(RGRM-07?MAE?)		37,600 [11.0]	25,750 [7.5]	11,850 [3.5]	11.00	13.00	76	1,025 [484]	
RCFL-A*3617(RGRM-09?ZAJ?)		38,500 [11.3]	27,450 [8.0]	11,050 [3.2]	11.00	13.00	76	1,225 [578]	
RCFL-A*3617(RGRM-10?ZAJ?)		38,500 [11.3]	27,100 [7.9]	11,400 [3.3]	11.00	13.00	76	1,150 [543]	
RCFL-A*3617(RHWB-04WMX36A)		38,500 [11.3]	27,100 [7.9]	11,400 [3.3]	11.50	13.50	76	1,150 [543]	
RCFL-A*3617(RHWB-06WMX48A)		38,500 [11.3]	27,100 [7.9]	11,400 [3.3]	11.00	13.00	76	1,150 [543]	
RCFL-A*3617(ROCA-070E03)		38,500 [11.3]	27,350 [8.0]	11,150 [3.3]	11.00	13.00	76	1,200 [566]	
RCFL-A*3617(ROCA-070E04)		38,500 [11.3]	27,350 [8.0]	11,150 [3.3]	11.00	13.00	76	1,200 [566]	
RCFL-A*3617(ROLA-070E03)		38,500 [11.3]	27,150 [8.0]	11,350 [3.3]	11.50	13.50	76	1,175 [554]	
RCFL-A*3617(ROLA-070E04)		38,500 [11.3]	27,150 [8.0]	11,350 [3.3]	11.50	13.50	76	1,175 [554]	
RCFL-A*3621		37,600 [11.0]	25,750 [7.5]	11,850 [3.5]	11.00	13.00	76	1,050 [495]	
RCFL-A*3621(RGFE-07?MCK?)		37,800 [11.1]	25,900 [7.6]	11,900 [3.5]	11.00	13.50	76	1,025 [484]	
RCFL-A*3621(RGFE-09?ZCM?)		38,500 [11.3]	27,300 [8.0]	11,200 [3.3]	11.00	13.00	76	1,200 [566]	
RCFL-A*3621(RGFE-10?ZCM?)		38,500 [11.3]	27,450 [8.0]	11,050 [3.2]	11.00	13.00	76	1,225 [578]	

① Highest sales volume tested combination required by D.O.E. test procedures.

[] Designates Metric Conversions



Performance Data @ AHRI Standard Conditions—Cooling

Model Numbers		80°F [26.5°C] DB/67°F [19.5°C] WB Indoor Air 95°F [35°C] DB Outdoor Air					Sound Rating dB	Indoor CFM [L/s]
Outdoor Unit RANL-	Indoor Coil and/or Air Handler	Total Capacity BTU/H [kW]	Net Sensible BTU/H [kW]	Net Latent BTU/H [kW]	EER	SEER		
Rev. 5/17/12	RCFL-A*3621(RGFG-07?MCK?)	37,800 [11.1]	25,800 [7.6]	12,000 [3.5]	11.00	13.00	76	1,050 [495]
	RCFL-A*3621(RGFG-09?ZCM?)	38,500 [11.3]	27,400 [8.0]	11,100 [3.3]	11.00	13.00	76	1,200 [566]
	RCFL-A*3621(RGFG-10?ZCM?)	38,500 [11.3]	27,400 [8.0]	11,100 [3.3]	11.00	13.00	76	1,200 [566]
	RCFL-A*3621(RGGE-06?MCK?)	38,500 [11.3]	28,000 [8.2]	10,500 [3.1]	11.00	13.50	76	1,200 [566]
	RCFL-A*3621(RGGE-07?MCK?)	38,000 [11.1]	26,050 [7.6]	11,950 [3.5]	11.50	13.50	76	1,025 [484]
	RCFL-A*3621(RGGE-09?ZCM?)	39,000 [11.4]	27,900 [8.2]	11,100 [3.3]	11.50	13.50	76	1,225 [578]
	RCFL-A*3621(RGGE-10?ZCM?)	38,500 [11.3]	27,300 [8.0]	11,200 [3.3]	11.00	13.50	76	1,200 [566]
	RCFL-A*3621(RGJF-06?MCK?)	38,500 [11.3]	28,000 [8.2]	10,500 [3.1]	11.00	13.50	76	1,200 [566]
	RCFL-A*3621(RGLE-07?AMK?)	38,500 [11.3]	27,950 [8.2]	10,550 [3.1]	11.50	13.50	76	1,200 [566]
	RCFL-A*3621(RGLE-10?BRM?)	39,000 [11.4]	28,350 [8.3]	10,650 [3.1]	12.00	14.50	76	1,200 [566]
	RCFL-A*3621(RGLT-07?AMK?)	38,500 [11.3]	27,100 [7.9]	11,400 [3.3]	11.00	13.00	76	1,150 [543]
	RCFL-A*3621(RGLT-07?BRQ?)	39,000 [11.4]	27,750 [8.1]	11,250 [3.3]	11.50	13.50	76	1,200 [566]
	RCFL-A*3621(RGLT-10?BRM?)	38,500 [11.3]	27,100 [7.9]	11,400 [3.3]	11.50	13.50	76	1,175 [554]
	RCFL-A*3621(RGPE-05?BMK?)	38,500 [11.3]	27,350 [8.0]	11,150 [3.3]	11.00	13.00	76	1,200 [566]
	RCFL-A*3621(RGPE-07?AMK?)	38,500 [11.3]	27,450 [8.0]	11,050 [3.2]	11.00	13.00	76	1,225 [578]
	RCFL-A*3621(RGPE-07?BRQ?)	38,000 [11.1]	25,950 [7.6]	12,050 [3.5]	11.50	14.00	76	1,025 [484]
	RCFL-A*3621(RGPE-10?BRM?)	38,000 [11.1]	26,000 [7.6]	12,000 [3.5]	11.50	14.00	76	1,075 [507]
RCFL-A*3621(RGPT-05?BMK?)	37,800 [11.1]	25,900 [7.6]	11,900 [3.5]	11.50	13.50	76	1,075 [507]	
RCFL-A*3621(RGPT-07?AMK?)	38,500 [11.3]	27,350 [8.0]	11,150 [3.3]	11.00	13.00	76	1,200 [566]	
RCFL-A*3621(RGPT-07?BRQ?)	38,500 [11.3]	27,100 [7.9]	11,400 [3.3]	11.50	13.50	76	1,175 [554]	
RCFL-A*3621(RGPT-10?BRM?)	39,000 [11.4]	27,700 [8.1]	11,300 [3.3]	11.50	13.50	76	1,175 [554]	
RCFL-A*3621(RGRM-04?MAE?)	37,800 [11.1]	25,900 [7.6]	11,900 [3.5]	11.00	13.00	76	1,025 [484]	
RCFL-A*3621(RGRM-07?MAE?)	37,600 [11.0]	25,750 [7.5]	11,850 [3.5]	11.00	13.00	76	1,025 [484]	
RCFL-A*3621(RGRM-09?ZAJ?)	38,500 [11.3]	27,450 [8.0]	11,050 [3.2]	11.00	13.00	76	1,225 [578]	
RCFL-A*3621(RGRM-10?ZAJ?)	38,500 [11.3]	27,050 [7.9]	11,450 [3.4]	11.00	13.00	76	1,150 [543]	
RCFL-A*3621(RGRM-12?RAJ?)	39,000 [11.4]	27,900 [8.2]	11,100 [3.3]	11.50	13.50	76	1,225 [578]	
RCFL-A*3621(RGTM-07?RBG?)	38,500 [11.3]	27,550 [8.1]	10,950 [3.2]	11.50	14.00	76	1,125 [531]	
RCFL-A*3621(RGTM-09?ZAJ?)	38,500 [11.3]	27,400 [8.0]	11,100 [3.3]	11.50	14.00	76	1,100 [519]	
RCFL-A*3621(RHWB-04WMMX36A)	38,500 [11.3]	27,100 [7.9]	11,400 [3.3]	11.50	13.50	76	1,150 [543]	
RCFL-A*3621(RHWB-06WMMX48A)	38,500 [11.3]	27,200 [8.0]	11,300 [3.3]	11.50	13.00	76	1,175 [554]	
RCFL-A*3621(ROCA-070E03)	38,500 [11.3]	27,300 [8.0]	11,200 [3.3]	11.00	13.00	76	1,200 [566]	
RCFL-A*3621(ROCA-070E04)	38,500 [11.3]	27,300 [8.0]	11,200 [3.3]	11.00	13.00	76	1,200 [566]	
RCFL-A*3621(ROLA-070E03)	38,500 [11.3]	27,150 [8.0]	11,350 [3.3]	11.50	13.50	76	1,175 [554]	
RCFL-A*3621(ROLA-070E04)	38,500 [11.3]	27,150 [8.0]	11,350 [3.3]	11.50	13.50	76	1,175 [554]	
RCFL-H*3617(RGFE-07?MCK?)	37,800 [11.1]	25,900 [7.6]	11,900 [3.5]	11.00	13.50	76	1,025 [484]	
RCFL-H*3617(RGFG-07?MCK?)	37,800 [11.1]	25,800 [7.6]	12,000 [3.5]	11.00	13.00	76	1,050 [495]	
RCFL-H*3617(RGGE-06?MCK?)	38,500 [11.3]	28,000 [8.2]	10,500 [3.1]	11.00	13.50	76	1,200 [566]	
RCFL-H*3617(RGGE-07?MCK?)	38,000 [11.1]	26,050 [7.6]	11,950 [3.5]	11.50	13.50	76	1,025 [484]	
RCFL-H*3617(RGJF-06?MCK?)	38,500 [11.3]	28,000 [8.2]	10,500 [3.1]	11.00	13.50	76	1,200 [566]	
RCFL-H*3617(RGJF-07?MCK?)	38,500 [11.3]	28,050 [8.2]	10,450 [3.1]	11.00	13.50	76	1,200 [566]	
RCFL-H*3617(RGLE-07?AMK?)	38,500 [11.3]	27,950 [8.2]	10,550 [3.1]	11.50	13.50	76	1,200 [566]	
RCFL-H*3617(RGLT-07?AMK?)	38,500 [11.3]	27,300 [8.0]	11,200 [3.3]	11.00	13.00	76	1,200 [566]	
RCFL-H*3617(RGPE-05?BMK?)	38,500 [11.3]	28,000 [8.2]	10,500 [3.1]	11.00	13.50	76	1,200 [566]	
RCFL-H*3617(RGPE-07?AMK?)	38,500 [11.3]	27,450 [8.0]	11,050 [3.2]	11.00	13.00	76	1,225 [578]	
RCFL-H*3617(RGPT-05?BMK?)	38,000 [11.1]	26,700 [7.8]	11,300 [3.3]	11.00	13.00	76	1,175 [554]	
RCFL-H*3617(RGPT-07?AMK?)	38,500 [11.3]	27,200 [8.0]	11,300 [3.3]	11.00	13.00	76	1,175 [554]	
RCFL-H*3617(RGRM-04?MAE?)	37,800 [11.1]	25,900 [7.6]	11,900 [3.5]	11.00	13.00	76	1,025 [484]	
RCFL-H*3617(RGRM-07?MAE?)	37,600 [11.0]	25,750 [7.5]	11,850 [3.5]	11.00	13.00	76	1,025 [484]	

① Highest sales volume tested combination required by D.O.E. test procedures.

[] Designates Metric Conversions

Performance Data @ AHRI Standard Conditions—Cooling

Model Numbers		80°F [26.5°C] DB/67°F [19.5°C] WB Indoor Air 95°F [35°C] DB Outdoor Air					Sound Rating dB	Indoor CFM [L/s]
Outdoor Unit RANL-	Indoor Coil and/or Air Handler	Total Capacity BTU/H [kW]	Net Sensible BTU/H [kW]	Net Latent BTU/H [kW]	EER	SEER		
Rev. 5/17/12	RCFL-H*3617(RGRM-09?ZAJ?)	38,500 [11.3]	27,450 [8.0]	11,050 [3.2]	11.00	13.00	76	1,225 [578]
	RCFL-H*3617(RGRM-10?ZAJ?)	38,500 [11.3]	27,100 [7.9]	11,400 [3.3]	11.00	13.00	76	1,150 [543]
	RCFL-H*3617(RGTM-06?MAE?)	37,800 [11.1]	25,800 [7.6]	12,000 [3.5]	11.50	13.50	76	1,075 [507]
	RCFL-H*3617(RHWP-04WWMX36A)	38,500 [11.3]	27,100 [7.9]	11,400 [3.3]	11.50	13.50	76	1,150 [543]
	RCFL-H*3617(RHWP-06WWMX48A)	38,500 [11.3]	27,100 [7.9]	11,400 [3.3]	11.00	13.00	76	1,150 [543]
	RCFL-H*3617(ROCA-070E03)	38,500 [11.3]	27,350 [8.0]	11,150 [3.3]	11.00	13.00	76	1,200 [566]
	RCFL-H*3617(ROCA-070E04)	38,500 [11.3]	27,350 [8.0]	11,150 [3.3]	11.00	13.00	76	1,200 [566]
	RCFL-H*3617(ROLA-070E03)	38,500 [11.3]	27,150 [8.0]	11,350 [3.3]	11.50	13.50	76	1,175 [554]
	RCFL-H*3617(ROLA-070E04)	38,500 [11.3]	27,150 [8.0]	11,350 [3.3]	11.50	13.50	76	1,175 [554]
	RCFL-H*3621	37,600 [11.0]	25,750 [7.5]	11,850 [3.5]	11.00	13.00	76	1,050 [495]
	RCFL-H*3621(RGFE-07?MCK?)	37,800 [11.1]	25,900 [7.6]	11,900 [3.5]	11.00	13.50	76	1,025 [484]
	RCFL-H*3621(RGFE-09?ZCM?)	38,500 [11.3]	27,300 [8.0]	11,200 [3.3]	11.00	13.00	76	1,200 [566]
	RCFL-H*3621(RGFE-10?ZCM?)	38,500 [11.3]	27,450 [8.0]	11,050 [3.2]	11.00	13.00	76	1,225 [578]
	RCFL-H*3621(RGFG-07?MCK?)	37,800 [11.1]	25,800 [7.6]	12,000 [3.5]	11.00	13.00	76	1,050 [495]
	RCFL-H*3621(RGFG-09?ZCM?)	38,500 [11.3]	27,400 [8.0]	11,100 [3.3]	11.00	13.00	76	1,200 [566]
	RCFL-H*3621(RGFG-10?ZCM?)	38,500 [11.3]	27,400 [8.0]	11,100 [3.3]	11.00	13.00	76	1,200 [566]
	RCFL-H*3621(RGGE-06?MCK?)	38,500 [11.3]	28,000 [8.2]	10,500 [3.1]	11.00	13.50	76	1,200 [566]
	RCFL-H*3621(RGGE-07?MCK?)	38,000 [11.1]	26,050 [7.6]	11,950 [3.5]	11.50	13.50	76	1,025 [484]
	RCFL-H*3621(RGGE-09?ZCM?)	39,000 [11.4]	27,900 [8.2]	11,100 [3.3]	11.50	13.50	76	1,225 [578]
	RCFL-H*3621(RGGE-10?ZCM?)	38,500 [11.3]	27,300 [8.0]	11,200 [3.3]	11.00	13.50	76	1,200 [566]
	RCFL-H*3621(RGJF-06?MCK?)	38,500 [11.3]	28,000 [8.2]	10,500 [3.1]	11.00	13.50	76	1,200 [566]
	RCFL-H*3621(RGJF-07?MCK?)	38,500 [11.3]	28,000 [8.2]	10,500 [3.1]	11.00	13.50	76	1,200 [566]
	RCFL-H*3621(RGJF-09?ZCM?)	39,000 [11.4]	27,900 [8.2]	11,100 [3.3]	11.50	13.50	76	1,225 [578]
	RCFL-H*3621(RGJF-10?ZCM?)	38,500 [11.3]	27,950 [8.2]	10,550 [3.1]	11.50	13.50	76	1,200 [566]
	RCFL-H*3621(RGLE-07?AMK?)	38,500 [11.3]	27,950 [8.2]	10,550 [3.1]	11.50	13.50	76	1,200 [566]
	RCFL-H*3621(RGLE-10?BRM?)	39,000 [11.4]	28,350 [8.3]	10,650 [3.1]	12.00	14.50	76	1,200 [566]
	RCFL-H*3621(RGLT-07?AMK?)	38,500 [11.3]	27,100 [7.9]	11,400 [3.3]	11.00	13.00	76	1,150 [543]
	RCFL-H*3621(RGLT-07?BRQ?)	39,000 [11.4]	27,750 [8.1]	11,250 [3.3]	11.50	13.50	76	1,200 [566]
	RCFL-H*3621(RGLT-10?BRM?)	38,500 [11.3]	27,100 [7.9]	11,400 [3.3]	11.50	13.50	76	1,175 [554]
	RCFL-H*3621(RGPE-05?BMK?)	38,500 [11.3]	28,000 [8.2]	10,500 [3.1]	11.00	13.50	76	1,200 [566]
	RCFL-H*3621(RGPE-07?AMK?)	38,500 [11.3]	27,450 [8.0]	11,050 [3.2]	11.00	13.00	76	1,225 [578]
	RCFL-H*3621(RGPE-07?BRQ?)	38,000 [11.1]	25,950 [7.6]	12,050 [3.5]	11.50	14.00	76	1,025 [484]
	RCFL-H*3621(RGPE-10?BRM?)	38,000 [11.1]	26,000 [7.6]	12,000 [3.5]	11.50	14.00	76	1,075 [507]
RCFL-H*3621(RGPT-05?BMK?)	37,800 [11.1]	25,900 [7.6]	11,900 [3.5]	11.50	13.50	76	1,075 [507]	
RCFL-H*3621(RGPT-07?AMK?)	38,500 [11.3]	27,350 [8.0]	11,150 [3.3]	11.00	13.00	76	1,200 [566]	
RCFL-H*3621(RGPT-07?BRQ?)	38,500 [11.3]	27,100 [7.9]	11,400 [3.3]	11.50	13.50	76	1,175 [554]	
RCFL-H*3621(RGPT-10?BRM?)	39,000 [11.4]	27,700 [8.1]	11,300 [3.3]	11.50	13.50	76	1,175 [554]	
RCFL-H*3621(RGRM-04?MAE?)	37,800 [11.1]	25,900 [7.6]	11,900 [3.5]	11.00	13.00	76	1,025 [484]	
RCFL-H*3621(RGRM-07?MAE?)	37,600 [11.0]	25,750 [7.5]	11,850 [3.5]	11.00	13.00	76	1,025 [484]	
RCFL-H*3621(RGRM-07?YBG?)	37,600 [11.0]	25,800 [7.6]	11,800 [3.5]	11.00	13.00	76	1,050 [495]	
RCFL-H*3621(RGRM-09?ZAJ?)	37,800 [11.1]	26,000 [7.6]	11,800 [3.5]	11.50	13.50	76	1,075 [507]	
RCFL-H*3621(RGRM-10?ZAJ?)	38,500 [11.3]	27,050 [7.9]	11,450 [3.4]	11.00	13.00	76	1,150 [543]	
RCFL-H*3621(RGRM-12?RAJ?)	39,000 [11.4]	27,900 [8.2]	11,100 [3.3]	11.50	13.50	76	1,225 [578]	
RCFL-H*3621(RGTM-06?MAE?)	37,800 [11.1]	26,000 [7.6]	11,800 [3.5]	11.50	13.50	76	1,075 [507]	
RCFL-H*3621(RGTM-07?RBG?)	38,500 [11.3]	27,550 [8.1]	10,950 [3.2]	11.50	14.00	76	1,125 [531]	
RCFL-H*3621(RGTM-09?ZAJ?)	38,500 [11.3]	27,400 [8.0]	11,100 [3.3]	11.50	14.00	76	1,100 [519]	
RCFL-H*3621(RHWP-04WWMX36A)	38,500 [11.3]	27,100 [7.9]	11,400 [3.3]	11.50	13.50	76	1,150 [543]	
RCFL-H*3621(RHWP-06WWMX48A)	38,500 [11.3]	27,200 [8.0]	11,300 [3.3]	11.50	13.00	76	1,175 [554]	

① Highest sales volume tested combination required by D.O.E. test procedures.

[] Designates Metric Conversions



Performance Data @ AHRI Standard Conditions—Cooling

Model Numbers		80°F [26.5°C] DB/67°F [19.5°C] WB Indoor Air 95°F [35°C] DB Outdoor Air					Sound Rating dB	Indoor CFM [L/s]
Outdoor Unit RANL-	Indoor Coil and/or Air Handler	Total Capacity BTU/H [kW]	Net Sensible BTU/H [kW]	Net Latent BTU/H [kW]	EER	SEER		
Rev. 5/17/12	RCFL-H*3621(ROCA-070E03)	38,500 [11.3]	27,300 [8.0]	11,200 [3.3]	11.00	13.00	76	1,200 [566]
	RCFL-H*3621(ROCA-070E04)	38,500 [11.3]	27,300 [8.0]	11,200 [3.3]	11.00	13.00	76	1,200 [566]
	RCFL-H*3621(ROLA-070E03)	38,500 [11.3]	27,150 [8.0]	11,350 [3.3]	11.50	13.50	76	1,175 [554]
	RCFL-H*3621(ROLA-070E04)	38,500 [11.3]	27,150 [8.0]	11,350 [3.3]	11.50	13.50	76	1,175 [554]
	RBHP-21(RCHL-36A1)	38,000 [11.1]	25,800 [7.6]	12,200 [3.6]	11.50	14.00	76	1,200 [566]
	RCQD-3621(RGFE-06?MCK?)	39,500 [11.6]	28,200 [8.3]	11,300 [3.3]	11.00	13.50	76	1,200 [566]
	RCQD-3621(RGFE-07?MCK?)	39,500 [11.6]	28,200 [8.3]	11,300 [3.3]	11.00	13.00	76	1,225 [578]
	RCQD-3621(RGFE-09?ZCM?)	40,000 [11.7]	28,600 [8.4]	11,400 [3.3]	11.50	14.00	76	1,200 [566]
	RCQD-3621(RGFE-10?ZCM?)	40,000 [11.7]	28,600 [8.4]	11,400 [3.3]	11.50	14.00	76	1,225 [578]
	RCQD-3621(RGFG-06?MCK?)	39,500 [11.6]	29,100 [8.5]	10,400 [3.0]	11.50	13.50	76	1,200 [566]
	RCQD-3621(RGFG-07?MCK?)	40,000 [11.7]	29,750 [8.7]	10,250 [3.0]	11.00	13.50	76	1,225 [578]
	RCQD-3621(RGFG-09?ZCM?)	40,000 [11.7]	29,500 [8.6]	10,500 [3.1]	11.50	14.00	76	1,200 [566]
	RCQD-3621(RGFG-10?ZCM?)	40,000 [11.7]	29,500 [8.6]	10,500 [3.1]	11.50	14.00	76	1,200 [566]
	RCQD-3621(RGJF-06?MCK?)	39,500 [11.6]	28,150 [8.2]	11,350 [3.3]	11.50	13.50	76	1,200 [566]
	RCQD-3621(RGJF-07?MCK?)	39,500 [11.6]	28,150 [8.2]	11,350 [3.3]	11.00	13.50	76	1,200 [566]
	RCQD-3621(RGJF-09?ZCM?)	40,000 [11.7]	28,550 [8.4]	11,450 [3.4]	11.50	14.00	76	1,225 [578]
	RCQD-3621(RGJF-10?ZCM?)	40,000 [11.7]	28,550 [8.4]	11,450 [3.4]	11.50	14.00	76	1,200 [566]
RCQD-3621(RGPE-05?BMK?)	39,500 [11.6]	28,150 [8.2]	11,350 [3.3]	11.00	13.50	76	1,200 [566]	
RCQD-3621(RGPE-07?AMK?)	40,000 [11.7]	28,600 [8.4]	11,400 [3.3]	11.50	13.50	76	1,225 [578]	
RCQD-3621(RGPE-07?BRQ?)	40,000 [11.7]	28,500 [8.4]	11,500 [3.4]	12.00	14.50	76	1,225 [578]	
RCQD-3621(RGPE-10?BRM?)	39,500 [11.6]	27,350 [8.0]	12,150 [3.6]	12.00	14.50	76	1,075 [507]	
RCQD-3621(RGPT-05?BMK?)	39,500 [11.6]	28,700 [8.4]	10,800 [3.2]	11.00	13.50	76	1,100 [519]	
RCQD-3621(RGPT-07?AMK?)	39,500 [11.6]	28,700 [8.4]	10,800 [3.2]	11.50	13.50	76	1,100 [519]	
RCQD-3621(RGPT-07?BRQ?)	40,500 [11.9]	29,250 [8.6]	11,250 [3.3]	12.00	14.50	76	1,250 [590]	
RCQD-3621(RGPT-10?BRM?)	40,500 [11.9]	29,250 [8.6]	11,250 [3.3]	12.00	14.50	76	1,250 [590]	
RCQD-3621(RGRM-04?MAE?)	39,500 [11.6]	29,150 [8.5]	10,350 [3.0]	11.00	13.50	76	1,200 [566]	
RCQD-3621(RGRM-06?MAE?)	39,500 [11.6]	29,000 [8.5]	10,500 [3.1]	11.00	13.50	76	1,175 [554]	
RCQD-3621(RGRM-09?ZAJ?)	40,000 [11.7]	29,650 [8.7]	10,350 [3.0]	11.50	14.00	76	1,225 [578]	
RCQD-3621(RGRM-10?ZAJ?)	39,500 [11.6]	28,750 [8.4]	10,750 [3.1]	11.50	14.00	76	1,150 [543]	
RCQD-3621(RGTM-06?MAE?)	40,000 [11.7]	29,700 [8.7]	10,300 [3.0]	11.50	13.50	76	1,225 [578]	
RCQD-3621(RGTM-07?RBG?)	40,000 [11.7]	29,050 [8.5]	10,950 [3.2]	12.00	14.50	76	1,125 [531]	
RCQD-3621(RGTM-09?ZAJ?)	39,500 [11.6]	28,450 [8.3]	11,050 [3.2]	12.00	14.50	76	1,100 [519]	
RCQD-3621(RHWB-04WMX36A)	38,500 [11.3]	27,450 [8.0]	11,050 [3.2]	11.50	14.00	76	1,200 [566]	
RCQD-3621(ROCA-070E03)	40,000 [11.7]	28,600 [8.4]	11,400 [3.3]	11.50	14.00	76	1,200 [566]	
RCQD-3621(ROCA-070E04)	40,000 [11.7]	28,600 [8.4]	11,400 [3.3]	11.50	14.00	76	1,200 [566]	
RCQD-3621(ROLA-070E03)	40,000 [11.7]	28,550 [8.4]	11,450 [3.4]	11.50	14.00	76	1,175 [554]	
RCQD-3621(ROLA-070E04)	40,000 [11.7]	28,550 [8.4]	11,450 [3.4]	11.50	14.00	76	1,175 [554]	
RCQD-3621(ROLA-115E05)	40,000 [11.7]	28,500 [8.4]	11,500 [3.4]	12.00	14.50	76	1,200 [566]	
RCQD-3624(RGFG-09?ZCM?)	40,000 [11.7]	29,500 [8.6]	10,500 [3.1]	12.00	14.50	76	1,200 [566]	
RCQD-3624(RGFG-10?ZCM?)	40,000 [11.7]	29,500 [8.6]	10,500 [3.1]	11.50	14.00	76	1,200 [566]	
RCQD-3624(RGFG-12?RCM?)	40,500 [11.9]	30,100 [8.8]	10,400 [3.0]	12.00	14.50	76	1,225 [578]	
RCQD-3624(RGPT-07?BRQ?)	40,500 [11.9]	29,400 [8.6]	11,100 [3.3]	12.00	14.50	76	1,275 [602]	
RCQD-3624(RGPT-10?BRM?)	40,500 [11.9]	29,400 [8.6]	11,100 [3.3]	12.00	14.50	76	1,275 [602]	
RCQD-3624(RGPT-12?ARM?)	40,500 [11.9]	28,950 [8.5]	11,550 [3.4]	12.00	14.50	76	1,225 [578]	
RCQD-3624(RGRM-09?ZAJ?)	40,000 [11.7]	29,650 [8.7]	10,350 [3.0]	11.50	14.00	76	1,225 [578]	
RCQD-3624(RGRM-10?ZAJ?)	39,500 [11.6]	28,750 [8.4]	10,750 [3.1]	11.50	14.00	76	1,150 [543]	
RCQD-3624(RGRM-12?RAJ?)	40,500 [11.9]	30,100 [8.8]	10,400 [3.0]	12.00	14.50	76	1,225 [578]	
RCQD-3624(RGTM-07?RBG?)	40,000 [11.7]	29,050 [8.5]	10,950 [3.2]	12.00	14.50	76	1,125 [531]	

① Highest sales volume tested combination required by D.O.E. test procedures.

[] Designates Metric Conversions

Performance Data @ AHRI Standard Conditions—Cooling

Model Numbers		80°F [26.5°C] DB/67°F [19.5°C] WB Indoor Air 95°F [35°C] DB Outdoor Air					Sound Rating dB	Indoor CFM [L/s]
Outdoor Unit RANL-	Indoor Coil and/or Air Handler	Total Capacity BTU/H [kW]	Net Sensible BTU/H [kW]	Net Latent BTU/H [kW]	EER	SEER		
Rev. 5/17/12 037CAZ/ DAZ/JAZ	RCQD-3624(RGTM-09?ZAJ?)	39,500 [11.6]	28,450 [8.3]	11,050 [3.2]	12.00	14.50	76	1,100 [519]
	RCQD-3624(RGTM-10?RBJ?)	40,000 [11.7]	29,050 [8.5]	10,950 [3.2]	12.00	14.50	76	1,125 [531]
	RCQD-3624(ROCA-070E03)	40,000 [11.7]	28,550 [8.4]	11,450 [3.4]	11.50	14.00	76	1,200 [566]
	RCQD-3624(ROCA-070E04)	40,000 [11.7]	28,550 [8.4]	11,450 [3.4]	11.50	14.00	76	1,200 [566]
	RCQD-3624(ROLA-070E03)	40,000 [11.7]	28,500 [8.4]	11,500 [3.4]	12.00	14.50	76	1,175 [554]
	RCQD-3624(ROLA-070E04)	40,000 [11.7]	28,500 [8.4]	11,500 [3.4]	12.00	14.50	76	1,175 [554]
	RCQD-3624(ROLA-115E05)	40,000 [11.7]	28,500 [8.4]	11,500 [3.4]	12.00	14.50	76	1,200 [566]
	RHKL-HM3617(RCSL-H*3617)	39,000 [11.4]	27,700 [8.1]	11,300 [3.3]	11.50	14.00	76	1,200 [566]
	RHLL-HM3617(RCSL-H*3617)	39,000 [11.4]	27,700 [8.1]	11,300 [3.3]	11.50	14.00	76	1,200 [566]
	RHSL-HM3617(RCSL-H*3617)	37,800 [11.1]	26,200 [7.7]	11,600 [3.4]	11.00	13.00	76	1,100 [519]
	RHSL-HM3621(RCSL-H*3621)	37,800 [11.1]	26,200 [7.7]	11,600 [3.4]	11.00	13.00	76	1,100 [519]
043CAZ/ DAZ/JAZ	RCFL-A*4821 ①	41,500 [12.2]	29,700 [8.7]	11,800 [3.5]	10.50	13.00	76	1,400 [661]
	RCFL-A*4821(RGFE-09?ZCM?)	41,500 [12.2]	29,700 [8.7]	11,800 [3.5]	11.00	13.00	76	1,400 [661]
	RCFL-A*4821(RGFE-10?ZCM?)	41,000 [12.0]	28,100 [8.2]	12,900 [3.8]	11.00	13.00	76	1,225 [578]
	RCFL-A*4821(RGFG-09?ZCM?)	41,000 [12.0]	28,000 [8.2]	13,000 [3.8]	11.00	13.00	76	1,200 [566]
	RCFL-A*4821(RGFG-10?ZCM?)	41,000 [12.0]	28,000 [8.2]	13,000 [3.8]	11.00	13.00	76	1,200 [566]
	RCFL-A*4821(RGGE-06?MCK?)	41,000 [12.0]	28,050 [8.2]	12,950 [3.8]	11.00	13.00	76	1,200 [566]
	RCFL-A*4821(RGGE-07?MCK?)	40,500 [11.9]	27,550 [8.1]	12,950 [3.8]	11.00	13.00	76	1,200 [566]
	RCFL-A*4821(RGGE-09?ZCM?)	41,500 [12.2]	29,650 [8.7]	11,850 [3.5]	11.00	13.00	76	1,400 [661]
	RCFL-A*4821(RGGE-10?ZCM?)	41,500 [12.2]	29,650 [8.7]	11,850 [3.5]	11.00	13.00	76	1,400 [661]
	RCFL-A*4821(RGLE-07?AMK?)	41,000 [12.0]	28,000 [8.2]	13,000 [3.8]	11.00	13.00	76	1,200 [566]
	RCFL-A*4821(RGLE-10?BRM?)	41,500 [12.2]	28,400 [8.3]	13,100 [3.8]	11.50	14.00	76	1,200 [566]
	RCFL-A*4821(RGLT-07?AMK?)	41,500 [12.2]	29,600 [8.7]	11,900 [3.5]	11.00	13.00	76	1,325 [625]
	RCFL-A*4821(RGLT-07?BRQ?)	42,000 [12.3]	30,350 [8.9]	11,650 [3.4]	11.00	13.50	76	1,450 [684]
	RCFL-A*4821(RGLT-10?BRM?)	42,000 [12.3]	30,100 [8.8]	11,900 [3.5]	11.00	13.50	76	1,425 [672]
	RCFL-A*4821(RGPE-05?BMK?)	41,000 [12.0]	28,050 [8.2]	12,950 [3.8]	11.00	13.00	76	1,200 [566]
	RCFL-A*4821(RGPE-07?AMK?)	41,000 [12.0]	28,150 [8.2]	12,850 [3.8]	11.00	13.00	76	1,225 [578]
	RCFL-A*4821(RGPE-07?BRQ?)	42,000 [12.3]	30,100 [8.8]	11,900 [3.5]	11.00	13.50	76	1,400 [661]
	RCFL-A*4821(RGPE-10?BRM?)	42,000 [12.3]	30,100 [8.8]	11,900 [3.5]	11.00	13.50	76	1,400 [661]
	RCFL-A*4821(RGPT-05?BMK?)	41,000 [12.0]	28,200 [8.3]	12,800 [3.8]	11.00	13.00	76	1,225 [578]
	RCFL-A*4821(RGPT-07?AMK?)	41,000 [12.0]	28,300 [8.3]	12,700 [3.7]	11.00	13.00	76	1,250 [590]
	RCFL-A*4821(RGPT-07?BRQ?)	41,500 [12.2]	29,000 [8.5]	12,500 [3.7]	11.50	13.50	76	1,225 [578]
	RCFL-A*4821(RGPT-10?BRM?)	42,000 [12.3]	30,050 [8.8]	11,950 [3.5]	11.00	13.50	76	1,425 [672]
	RCFL-A*4821(RGRM-09?ZAJ?)	41,000 [12.0]	28,150 [8.2]	12,850 [3.8]	11.00	13.00	76	1,225 [578]
	RCFL-A*4821(RGRM-10?ZAJ?)	40,500 [11.9]	27,250 [8.0]	13,250 [3.9]	11.00	13.00	76	1,150 [543]
	RCFL-A*4821(RGRM-12?RAJ?)	41,500 [12.2]	29,650 [8.7]	11,850 [3.5]	11.00	13.00	76	1,425 [672]
	RCFL-A*4821(RGTM-06?MAE?)	41,000 [12.0]	28,100 [8.2]	12,900 [3.8]	11.00	13.00	76	1,225 [578]
	RCFL-A*4821(RGTM-07?RBG?)	41,500 [12.2]	29,000 [8.5]	12,500 [3.7]	11.00	13.50	76	1,325 [625]
	RCFL-A*4821(RGTM-09?ZAJ?)	41,500 [12.2]	28,600 [8.4]	12,900 [3.8]	11.50	14.00	76	1,250 [590]
	RCFL-A*4821(RHWB-04WMX36A)	41,000 [12.0]	28,100 [8.2]	12,900 [3.8]	11.00	13.50	76	1,200 [566]
	RCFL-A*4821(RHWB-06WMX48A)	41,000 [12.0]	28,100 [8.2]	12,900 [3.8]	11.00	13.00	76	1,200 [566]
	RCFL-A*4821(ROCA-070E03)	41,000 [12.0]	28,000 [8.2]	13,000 [3.8]	11.00	13.00	76	1,200 [566]
	RCFL-A*4821(ROCA-070E04)	41,000 [12.0]	28,000 [8.2]	13,000 [3.8]	11.00	13.00	76	1,200 [566]
	RCFL-A*4821(ROLA-070E03)	41,000 [12.0]	27,800 [8.1]	13,200 [3.9]	11.00	13.50	76	1,175 [554]
	RCFL-A*4821(ROLA-070E04)	42,000 [12.3]	30,100 [8.8]	11,900 [3.5]	11.00	13.50	76	1,375 [649]
	RCFL-A*4821(ROLA-115E05)	41,000 [12.0]	27,900 [8.2]	13,100 [3.8]	11.50	13.50	76	1,200 [566]
	RCFL-A*4824	41,500 [12.2]	29,700 [8.7]	11,800 [3.5]	10.50	13.00	76	1,400 [661]
RCFL-A*4824(RGFE-09?ZCM?)	42,500 [12.5]	30,450 [8.9]	12,050 [3.5]	11.00	13.00	76	1,400 [661]	

① Highest sales volume tested combination required by D.O.E. test procedures.

[] Designates Metric Conversions



Performance Data @ AHRI Standard Conditions—Cooling

Model Numbers		80°F [26.5°C] DB/67°F [19.5°C] WB Indoor Air 95°F [35°C] DB Outdoor Air					Sound Rating dB	Indoor CFM [L/s]
Outdoor Unit RANL-	Indoor Coil and/or Air Handler	Total Capacity BTU/H [kW]	Net Sensible BTU/H [kW]	Net Latent BTU/H [kW]	EER	SEER		
Rev. 5/17/12	RCFL-A*4824(RGFE-10?ZCM?)	42,500 [12.5]	30,450 [8.9]	12,050 [3.5]	10.50	13.00	76	1,425 [672]
	RCFL-A*4824(RGFE-12?RCM?)	42,000 [12.3]	28,800 [8.4]	13,200 [3.9]	11.50	14.00	76	1,225 [578]
	RCFL-A*4824(RGFG-09?ZCM?)	41,000 [12.0]	28,000 [8.2]	13,000 [3.8]	11.00	13.50	76	1,200 [566]
	RCFL-A*4824(RGFG-10?ZCM?)	41,000 [12.0]	28,000 [8.2]	13,000 [3.8]	11.00	13.00	76	1,200 [566]
	RCFL-A*4824(RGFG-12?RCM?)	41,500 [12.2]	28,400 [8.3]	13,100 [3.8]	11.50	13.50	76	1,225 [578]
	RCFL-A*4824(RGGE-09?ZCM?)	42,500 [12.5]	30,400 [8.9]	12,100 [3.5]	11.00	13.00	76	1,400 [661]
	RCFL-A*4824(RGGE-10?ZCM?)	42,500 [12.5]	30,450 [8.9]	12,050 [3.5]	11.00	13.00	76	1,400 [661]
	RCFL-A*4824(RGGE-12?RCM?)	42,000 [12.3]	28,650 [8.4]	13,350 [3.9]	11.50	14.00	76	1,200 [566]
	RCFL-A*4824(RGLE-10?BRM?)	42,000 [12.3]	28,600 [8.4]	13,400 [3.9]	11.50	14.00	76	1,200 [566]
	RCFL-A*4824(RGLE-12?ARM?)	42,000 [12.3]	28,750 [8.4]	13,250 [3.9]	11.50	14.00	76	1,225 [578]
	RCFL-A*4824(RGLT-07?BRQ?)	42,000 [12.3]	30,350 [8.9]	11,650 [3.4]	11.00	13.50	76	1,450 [684]
	RCFL-A*4824(RGLT-10?BRM?)	42,000 [12.3]	30,100 [8.8]	11,900 [3.5]	11.00	13.50	76	1,425 [672]
	RCFL-A*4824(RGLT-12?ARM?)	42,000 [12.3]	30,000 [8.8]	12,000 [3.5]	11.00	13.50	76	1,375 [649]
	RCFL-A*4824(RGPE-07?BRQ?)	42,000 [12.3]	28,800 [8.4]	13,200 [3.9]	11.50	14.00	76	1,225 [578]
	RCFL-A*4824(RGPE-10?BRM?)	42,000 [12.3]	28,750 [8.4]	13,250 [3.9]	11.50	14.00	76	1,225 [578]
	RCFL-A*4824(RGPE-12?ARM?)	42,000 [12.3]	28,600 [8.4]	13,400 [3.9]	11.50	14.00	76	1,200 [566]
	RCFL-A*4824(RGPT-07?BRQ?)	41,500 [12.2]	28,650 [8.4]	12,850 [3.8]	11.50	14.00	76	1,250 [590]
	RCFL-A*4824(RGPT-10?BRM?)	42,000 [12.3]	30,050 [8.8]	11,950 [3.5]	11.00	13.50	76	1,425 [672]
	RCFL-A*4824(RGPT-12?ARM?)	42,000 [12.3]	30,000 [8.8]	12,000 [3.5]	11.50	14.00	76	1,375 [649]
	043CAZ/ DAZ/JAZ	RCFL-A*4824(RGRM-09?ZAJ?)	41,000 [12.0]	28,150 [8.2]	12,850 [3.8]	11.00	13.00	76
RCFL-A*4824(RGRM-10?ZAJ?)		40,500 [11.9]	27,250 [8.0]	13,250 [3.9]	11.00	13.00	76	1,150 [543]
RCFL-A*4824(RGRM-12?RAJ?)		41,500 [12.2]	29,650 [8.7]	11,850 [3.5]	11.00	13.00	76	1,425 [672]
RCFL-A*4824(RGTM-07?RBG?)		42,500 [12.5]	29,900 [8.8]	12,600 [3.7]	11.00	13.50	76	1,325 [625]
RCFL-A*4824(RGTM-09?ZAJ?)		42,000 [12.3]	28,950 [8.5]	13,050 [3.8]	11.00	13.50	76	1,250 [590]
RCFL-A*4824(RGTM-10?RBJ?)		42,000 [12.3]	28,800 [8.4]	13,200 [3.9]	11.50	14.00	76	1,225 [578]
RCFL-A*4824(RHWB-08WRX60A)		42,000 [12.3]	30,500 [8.9]	11,500 [3.4]	11.50	13.50	76	1,450 [684]
RCFL-A*4824(RHWB-10WRX60A)		42,000 [12.3]	30,200 [8.8]	11,800 [3.5]	11.50	14.00	76	1,400 [661]
RCFL-A*4824(ROCA-070E03)		41,000 [12.0]	28,000 [8.2]	13,000 [3.8]	11.00	13.50	76	1,200 [566]
RCFL-A*4824(ROCA-070E04)		41,000 [12.0]	28,000 [8.2]	13,000 [3.8]	11.00	13.50	76	1,200 [566]
RCFL-A*4824(ROLA-070E03)		41,000 [12.0]	27,800 [8.1]	13,200 [3.9]	11.00	13.50	76	1,175 [554]
RCFL-A*4824(ROLA-070E04)		42,000 [12.3]	30,100 [8.8]	11,900 [3.5]	11.00	13.50	76	1,375 [649]
RCFL-A*4824(ROLA-115E05)		41,000 [12.0]	27,900 [8.2]	13,100 [3.8]	11.50	13.50	76	1,200 [566]
RCFL-H*4821(RGFE-06?MCK?)		41,500 [12.2]	28,350 [8.3]	13,150 [3.9]	11.00	13.00	76	1,200 [566]
RCFL-H*4821(RGFE-09?ZCM?)		42,500 [12.5]	30,450 [8.9]	12,050 [3.5]	11.00	13.00	76	1,400 [661]
RCFL-H*4821(RGFE-10?ZCM?)		42,500 [12.5]	30,450 [8.9]	12,050 [3.5]	10.50	13.00	76	1,425 [672]
RCFL-H*4821(RGFG-09?ZCM?)		41,000 [12.0]	28,000 [8.2]	13,000 [3.8]	11.00	13.50	76	1,200 [566]
RCFL-H*4821(RGFG-10?ZCM?)		41,000 [12.0]	28,000 [8.2]	13,000 [3.8]	11.00	13.00	76	1,200 [566]
RCFL-H*4821(RGGE-06?MCK?)		41,500 [12.2]	28,250 [8.3]	13,250 [3.9]	11.00	13.00	76	1,200 [566]
RCFL-H*4821(RGGE-07?MCK?)		41,500 [12.2]	28,300 [8.3]	13,200 [3.9]	11.00	13.00	76	1,200 [566]
RCFL-H*4821(RGGE-09?ZCM?)	42,500 [12.5]	30,400 [8.9]	12,100 [3.5]	11.00	13.00	76	1,400 [661]	
RCFL-H*4821(RGGE-10?ZCM?)	42,500 [12.5]	30,450 [8.9]	12,050 [3.5]	11.00	13.00	76	1,400 [661]	
RCFL-H*4821(RGJF-06?MCK?)	41,500 [12.2]	28,250 [8.3]	13,250 [3.9]	11.00	13.00	76	1,200 [566]	
RCFL-H*4821(RGJF-07?MCK?)	41,500 [12.2]	28,300 [8.3]	13,200 [3.9]	11.00	13.00	76	1,200 [566]	
RCFL-H*4821(RGJF-09?ZCM?)	42,500 [12.5]	30,400 [8.9]	12,100 [3.5]	11.00	13.00	76	1,400 [661]	
RCFL-H*4821(RGJF-10?ZCM?)	42,500 [12.5]	30,400 [8.9]	12,100 [3.5]	11.00	13.00	76	1,400 [661]	
RCFL-H*4821(RGLE-07?AMK?)	42,000 [12.3]	28,750 [8.4]	13,250 [3.9]	11.00	13.50	76	1,200 [566]	
RCFL-H*4821(RGLE-10?BRM?)	42,000 [12.3]	28,600 [8.4]	13,400 [3.9]	11.50	14.00	76	1,200 [566]	
RCFL-H*4821(RGLT-07?AMK?)	41,500 [12.2]	29,300 [8.6]	12,200 [3.6]	11.00	13.00	76	1,325 [625]	

① Highest sales volume tested combination required by D.O.E. test procedures.

[] Designates Metric Conversions

Performance Data @ AHRI Standard Conditions—Cooling

Model Numbers		80°F [26.5°C] DB/67°F [19.5°C] WB Indoor Air 95°F [35°C] DB Outdoor Air					Sound Rating dB	Indoor CFM [L/s]
Outdoor Unit RANL-	Indoor Coil and/or Air Handler	Total Capacity BTU/H [kW]	Net Sensible BTU/H [kW]	Net Latent BTU/H [kW]	EER	SEER		
Rev. 5/17/12	RCFL-H*4821(RGLT-07?BRQ?)	42,000 [12.3]	30,350 [8.9]	11,650 [3.4]	11.00	13.50	76	1,450 [684]
	RCFL-H*4821(RGLT-10?BRM?)	42,000 [12.3]	30,100 [8.8]	11,900 [3.5]	11.00	13.50	76	1,425 [672]
	RCFL-H*4821(RGPE-05?BMK?)	41,500 [12.2]	28,250 [8.3]	13,250 [3.9]	11.00	13.00	76	1,200 [566]
	RCFL-H*4821(RGPE-07?AMK?)	42,000 [12.3]	28,900 [8.5]	13,100 [3.8]	11.00	13.50	76	1,225 [578]
	RCFL-H*4821(RGPE-07?BRQ?)	42,000 [12.3]	28,800 [8.4]	13,200 [3.9]	11.50	14.00	76	1,225 [578]
	RCFL-H*4821(RGPE-10?BRM?)	42,000 [12.3]	28,750 [8.4]	13,250 [3.9]	11.50	14.00	76	1,225 [578]
	RCFL-H*4821(RGPT-05?BMK?)	41,000 [12.0]	28,200 [8.3]	12,800 [3.8]	11.00	13.00	76	1,225 [578]
	RCFL-H*4821(RGPT-07?AMK?)	41,000 [12.0]	28,300 [8.3]	12,700 [3.7]	11.00	13.00	76	1,250 [590]
	RCFL-H*4821(RGPT-07?BRQ?)	41,500 [12.2]	28,650 [8.4]	12,850 [3.8]	11.50	14.00	76	1,250 [590]
	RCFL-H*4821(RGPT-10?BRM?)	42,000 [12.3]	30,050 [8.8]	11,950 [3.5]	11.00	13.50	76	1,425 [672]
	RCFL-H*4821(RGRM-09?ZAJ?)	41,000 [12.0]	28,150 [8.2]	12,850 [3.8]	11.00	13.00	76	1,225 [578]
	RCFL-H*4821(RGRM-10?ZAJ?)	40,500 [11.9]	27,250 [8.0]	13,250 [3.9]	11.00	13.00	76	1,150 [543]
043CAZ/ DAZ/JAZ	RCFL-H*4821(RGRM-12?RAJ?)	41,500 [12.2]	29,650 [8.7]	11,850 [3.5]	11.00	13.00	76	1,425 [672]
	RCFL-H*4821(RGTM-06?MAE?)	41,500 [12.2]	28,450 [8.3]	13,050 [3.8]	11.00	13.00	76	1,225 [578]
	RCFL-H*4821(RGTM-07?RBG?)	42,500 [12.5]	29,900 [8.8]	12,600 [3.7]	11.00	13.50	76	1,325 [625]
	RCFL-H*4821(RGTM-09?ZAJ?)	42,000 [12.3]	28,950 [8.5]	13,050 [3.8]	11.00	13.50	76	1,250 [590]
	RCFL-H*4821(RHWB-04WMMX36A)	41,000 [12.0]	28,100 [8.2]	12,900 [3.8]	11.00	13.50	76	1,200 [566]
	RCFL-H*4821(RHWB-06WMMX48A)	41,000 [12.0]	28,100 [8.2]	12,900 [3.8]	11.00	13.00	76	1,200 [566]
	RCFL-H*4821(ROCA-070E03)	41,000 [12.0]	28,000 [8.2]	13,000 [3.8]	11.00	13.50	76	1,200 [566]
	RCFL-H*4821(ROCA-070E04)	41,000 [12.0]	28,000 [8.2]	13,000 [3.8]	11.00	13.50	76	1,200 [566]
	RCFL-H*4821(ROLA-070E03)	41,000 [12.0]	27,800 [8.1]	13,200 [3.9]	11.00	13.50	76	1,175 [554]
	RCFL-H*4821(ROLA-070E04)	42,000 [12.3]	30,100 [8.8]	11,900 [3.5]	11.00	13.50	76	1,375 [649]
	RCFL-H*4821(ROLA-115E05)	41,000 [12.0]	27,900 [8.2]	13,100 [3.8]	11.50	13.50	76	1,200 [566]
	RCFL-H*4824	41,500 [12.2]	29,700 [8.7]	11,800 [3.5]	10.50	13.00	76	1,400 [661]
	RCFL-H*4824(RGFE-09?ZCM?)	42,500 [12.5]	30,450 [8.9]	12,050 [3.5]	11.00	13.00	76	1,400 [661]
	RCFL-H*4824(RGFE-10?ZCM?)	42,500 [12.5]	30,500 [8.9]	12,000 [3.5]	10.50	13.00	76	1,425 [672]
	RCFL-H*4824(RGFE-12?RCM?)	43,000 [12.6]	31,200 [9.1]	11,800 [3.5]	11.00	13.00	76	1,450 [684]
	RCFL-H*4824(RGFG-09?ZCM?)	41,000 [12.0]	28,000 [8.2]	13,000 [3.8]	11.00	13.00	76	1,200 [566]
	RCFL-H*4824(RGFG-10?ZCM?)	41,000 [12.0]	28,000 [8.2]	13,000 [3.8]	11.00	13.00	76	1,200 [566]
	RCFL-H*4824(RGFG-12?RCM?)	41,500 [12.2]	28,400 [8.3]	13,100 [3.8]	11.50	13.50	76	1,225 [578]
	RCFL-H*4824(RGGE-09?ZCM?)	42,500 [12.5]	30,400 [8.9]	12,100 [3.5]	11.00	13.00	76	1,400 [661]
	RCFL-H*4824(RGGE-10?ZCM?)	42,500 [12.5]	30,450 [8.9]	12,050 [3.5]	11.00	13.00	76	1,400 [661]
	RCFL-H*4824(RGGE-12?RCM?)	42,000 [12.3]	28,650 [8.4]	13,350 [3.9]	11.50	14.00	76	1,200 [566]
	RCFL-H*4824(RGJF-09?ZCM?)	42,500 [12.5]	30,400 [8.9]	12,100 [3.5]	11.00	13.00	76	1,400 [661]
	RCFL-H*4824(RGJF-10?ZCM?)	42,500 [12.5]	30,400 [8.9]	12,100 [3.5]	11.00	13.00	76	1,400 [661]
	RCFL-H*4824(RGJF-12?RCM?)	42,000 [12.3]	28,650 [8.4]	13,350 [3.9]	11.50	14.00	76	1,200 [566]
	RCFL-H*4824(RGLE-10?BRM?)	42,000 [12.3]	28,600 [8.4]	13,400 [3.9]	11.50	14.00	76	1,200 [566]
	RCFL-H*4824(RGLE-12?ARM?)	42,000 [12.3]	28,750 [8.4]	13,250 [3.9]	11.50	14.00	76	1,225 [578]
	RCFL-H*4824(RGLT-07?BRQ?)	42,000 [12.3]	30,350 [8.9]	11,650 [3.4]	11.00	13.50	76	1,450 [684]
	RCFL-H*4824(RGLT-10?BRM?)	42,000 [12.3]	30,100 [8.8]	11,900 [3.5]	11.00	13.50	76	1,425 [672]
	RCFL-H*4824(RGLT-12?ARM?)	42,000 [12.3]	30,000 [8.8]	12,000 [3.5]	11.00	13.50	76	1,375 [649]
	RCFL-H*4824(RGPE-07?BRQ?)	42,000 [12.3]	28,800 [8.4]	13,200 [3.9]	11.50	14.00	76	1,225 [578]
	RCFL-H*4824(RGPE-10?BRM?)	42,000 [12.3]	28,750 [8.4]	13,250 [3.9]	11.50	14.00	76	1,225 [578]
	RCFL-H*4824(RGPE-12?ARM?)	42,000 [12.3]	28,600 [8.4]	13,400 [3.9]	11.50	14.00	76	1,200 [566]
	RCFL-H*4824(RGPT-07?BRQ?)	42,000 [12.3]	30,200 [8.8]	11,800 [3.5]	11.00	13.50	76	1,425 [672]
	RCFL-H*4824(RGPT-10?BRM?)	42,000 [12.3]	30,050 [8.8]	11,950 [3.5]	11.00	13.50	76	1,425 [672]
	RCFL-H*4824(RGPT-12?ARM?)	42,000 [12.3]	30,000 [8.8]	12,000 [3.5]	11.50	14.00	76	1,375 [649]
	RCFL-H*4824(RGRM-09?ZAJ?)	41,000 [12.0]	28,150 [8.2]	12,850 [3.8]	11.00	13.00	76	1,225 [578]

① Highest sales volume tested combination required by D.O.E. test procedures.

[] Designates Metric Conversions



Performance Data @ AHRI Standard Conditions—Cooling

Model Numbers		80°F [26.5°C] DB/67°F [19.5°C] WB Indoor Air 95°F [35°C] DB Outdoor Air					Sound Rating dB	Indoor CFM [L/s]
Outdoor Unit RANL-	Indoor Coil and/or Air Handler	Total Capacity BTU/H [kW]	Net Sensible BTU/H [kW]	Net Latent BTU/H [kW]	EER	SEER		
Rev. 5/17/12	RCFL-H*4824(RGRM-10?ZAJ?)	40,500 [11.9]	27,250 [8.0]	13,250 [3.9]	11.00	13.00	76	1,150 [543]
	RCFL-H*4824(RGRM-12?RAJ?)	41,500 [12.2]	29,650 [8.7]	11,850 [3.5]	11.00	13.00	76	1,425 [672]
	RCFL-H*4824(RGTM-07?RBG?)	42,500 [12.5]	29,900 [8.8]	12,600 [3.7]	11.00	13.50	76	1,325 [625]
	RCFL-H*4824(RGTM-09?ZAJ?)	42,000 [12.3]	28,950 [8.5]	13,050 [3.8]	11.00	13.50	76	1,250 [590]
	RCFL-H*4824(RGTM-10?RBJ?)	42,000 [12.3]	28,800 [8.4]	13,200 [3.9]	11.50	14.00	76	1,225 [578]
	RCFL-H*4824(RHWB-08WRX60A)	42,000 [12.3]	30,500 [8.9]	11,500 [3.4]	11.50	13.50	76	1,450 [684]
	RCFL-H*4824(RHWB-10WRX60A)	42,000 [12.3]	30,200 [8.8]	11,800 [3.5]	11.50	14.00	76	1,400 [661]
	RCFL-H*4824(ROCA-070E03)	41,000 [12.0]	28,000 [8.2]	13,000 [3.8]	11.00	13.00	76	1,200 [566]
	RCFL-H*4824(ROCA-070E04)	41,000 [12.0]	28,000 [8.2]	13,000 [3.8]	11.00	13.00	76	1,200 [566]
	RCFL-H*4824(ROLA-070E03)	41,000 [12.0]	27,800 [8.1]	13,200 [3.9]	11.00	13.50	76	1,175 [554]
	RCFL-H*4824(ROLA-070E04)	42,000 [12.3]	30,100 [8.8]	11,900 [3.5]	11.00	13.50	76	1,375 [649]
	RCFL-H*4824(ROLA-115E05)	41,000 [12.0]	27,900 [8.2]	13,100 [3.8]	11.50	13.50	76	1,200 [566]
043CAZ/ DAZ/JAZ	RBHP-24(RCHL-48A1)	41,000 [12.0]	28,100 [8.2]	12,900 [3.8]	11.50	14.00	76	1,400 [661]
	RCQD-4821(RGFE-06?MCK?)	41,000 [12.0]	28,200 [8.3]	12,800 [3.8]	10.50	13.00	76	1,200 [566]
	RCQD-4821(RGFE-09?ZCM?)	42,000 [12.3]	30,300 [8.9]	11,700 [3.4]	11.00	13.00	76	1,400 [661]
	RCQD-4821(RGFE-10?ZCM?)	41,500 [12.2]	28,700 [8.4]	12,800 [3.8]	11.00	13.50	76	1,225 [578]
	RCQD-4821(RGFG-09?ZCM?)	40,500 [11.9]	27,850 [8.2]	12,650 [3.7]	11.00	13.00	76	1,200 [566]
	RCQD-4821(RGFG-10?ZCM?)	40,500 [11.9]	27,850 [8.2]	12,650 [3.7]	11.00	13.00	76	1,200 [566]
	RCQD-4821(RGJF-06?MCK?)	41,500 [12.2]	28,600 [8.4]	12,900 [3.8]	11.00	13.00	76	1,200 [566]
	RCQD-4821(RGJF-07?MCK?)	41,500 [12.2]	28,650 [8.4]	12,850 [3.8]	11.00	13.00	76	1,200 [566]
	RCQD-4821(RGJF-09?ZCM?)	42,500 [12.5]	30,750 [9.0]	11,750 [3.4]	11.00	13.00	76	1,400 [661]
	RCQD-4821(RGJF-10?ZCM?)	42,500 [12.5]	30,750 [9.0]	11,750 [3.4]	11.00	13.00	76	1,400 [661]
	RCQD-4821(RGPE-05?BMK?)	41,500 [12.2]	28,650 [8.4]	12,850 [3.8]	11.00	13.00	76	1,200 [566]
	RCQD-4821(RGPE-07?AMK?)	41,500 [12.2]	28,750 [8.4]	12,750 [3.7]	11.00	13.00	76	1,225 [578]
	RCQD-4821(RGPE-07?BRQ?)	42,000 [12.3]	29,150 [8.5]	12,850 [3.8]	11.50	14.00	76	1,225 [578]
	RCQD-4821(RGPE-10?BRM?)	42,000 [12.3]	29,150 [8.5]	12,850 [3.8]	11.50	14.00	76	1,225 [578]
	RCQD-4821(RGPT-05?BMK?)	41,500 [12.2]	28,800 [8.4]	12,700 [3.7]	11.00	13.00	76	1,225 [578]
	RCQD-4821(RGPT-07?AMK?)	42,000 [12.3]	29,850 [8.7]	12,150 [3.6]	11.00	13.00	76	1,325 [625]
	RCQD-4821(RGPT-07?BRQ?)	42,000 [12.3]	29,100 [8.5]	12,900 [3.8]	11.50	14.00	76	1,225 [578]
	RCQD-4821(RGPT-10?BRM?)	42,000 [12.3]	29,100 [8.5]	12,900 [3.8]	11.50	14.00	76	1,225 [578]
	RCQD-4821(RHWB-04WMX36A)	41,000 [12.0]	28,500 [8.4]	12,500 [3.7]	11.00	13.50	76	1,200 [566]
	RCQD-4821(RHWB-06WMX48A)	41,000 [12.0]	28,500 [8.4]	12,500 [3.7]	11.00	13.50	76	1,200 [566]
	RCQD-4821(ROCA-070E03)	41,500 [12.2]	28,600 [8.4]	12,900 [3.8]	11.00	13.50	76	1,200 [566]
	RCQD-4821(ROCA-070E04)	41,500 [12.2]	28,600 [8.4]	12,900 [3.8]	11.00	13.50	76	1,200 [566]
	RCQD-4821(ROLA-070E04)	42,500 [12.5]	30,700 [9.0]	11,800 [3.5]	11.00	13.50	76	1,375 [649]
	RCQD-4821(ROLA-115E05)	42,000 [12.3]	29,000 [8.5]	13,000 [3.8]	11.50	13.50	76	1,200 [566]
	RCQD-4824(RGFE-09?ZCM?)	42,500 [12.5]	30,750 [9.0]	11,750 [3.4]	11.00	13.00	76	1,400 [661]
	RCQD-4824(RGFE-10?ZCM?)	42,000 [12.3]	30,300 [8.9]	11,700 [3.4]	11.00	13.00	76	1,425 [672]
	RCQD-4824(RGFE-12?RCM?)	42,500 [12.5]	31,000 [9.1]	11,500 [3.4]	11.00	13.50	76	1,450 [684]
	RCQD-4824(RGFG-09?ZCM?)	41,000 [12.0]	28,300 [8.3]	12,700 [3.7]	11.00	13.50	76	1,200 [566]
	RCQD-4824(RGFG-10?ZCM?)	41,500 [12.2]	30,000 [8.8]	11,500 [3.4]	11.00	13.00	76	1,400 [661]
	RCQD-4824(RGFG-12?RCM?)	41,000 [12.0]	28,400 [8.3]	12,600 [3.7]	11.50	13.50	76	1,225 [578]
	RCQD-4824(RGJF-09?ZCM?)	42,500 [12.5]	30,700 [9.0]	11,800 [3.5]	11.00	13.00	76	1,400 [661]
	RCQD-4824(RGJF-10?ZCM?)	42,500 [12.5]	30,750 [9.0]	11,750 [3.4]	11.00	13.00	76	1,400 [661]
	RCQD-4824(RGJF-12?RCM?)	42,000 [12.3]	29,000 [8.5]	13,000 [3.8]	11.50	14.00	76	1,200 [566]
	RCQD-4824(RGPE-07?BRQ?)	42,000 [12.3]	29,100 [8.5]	12,900 [3.8]	11.50	14.00	76	1,225 [578]
	RCQD-4824(RGPE-10?BRM?)	42,000 [12.3]	29,100 [8.5]	12,900 [3.8]	11.50	14.00	76	1,225 [578]
	RCQD-4824(RGPE-12?ARM?)	42,000 [12.3]	28,950 [8.5]	13,050 [3.8]	11.50	14.00	76	1,200 [566]

① Highest sales volume tested combination required by D.O.E. test procedures.

[] Designates Metric Conversions

Performance Data @ AHRI Standard Conditions—Cooling

Model Numbers		80°F [26.5°C] DB/67°F [19.5°C] WB Indoor Air 95°F [35°C] DB Outdoor Air					Sound Rating dB	Indoor CFM [L/s]
Outdoor Unit RANL-	Indoor Coil and/or Air Handler	Total Capacity BTU/H [kW]	Net Sensible BTU/H [kW]	Net Latent BTU/H [kW]	EER	SEER		
Rev. 5/17/12 043CAZ/ DAZ/JAZ	RCQD-4824(RGPT-07?BRQ?)	42,000 [12.3]	29,250 [8.6]	12,750 [3.7]	11.50	14.00	76	1,250 [590]
	RCQD-4824(RGPT-10?BRM?)	42,000 [12.3]	29,250 [8.6]	12,750 [3.7]	11.50	14.00	76	1,250 [590]
	RCQD-4824(RGPT-12?ARM?)	43,000 [12.6]	31,100 [9.1]	11,900 [3.5]	11.50	14.00	76	1,400 [661]
	RCQD-4824(RHWB-08WRX60A)	42,000 [12.3]	30,600 [9.0]	11,400 [3.3]	11.50	14.00	76	1,400 [661]
	RCQD-4824(RHWB-10WRX60A)	42,500 [12.5]	31,400 [9.2]	11,100 [3.3]	11.50	14.00	76	1,450 [684]
	RCQD-4824(ROCA-070E03)	41,500 [12.2]	28,550 [8.4]	12,950 [3.8]	11.00	13.50	76	1,200 [566]
	RCQD-4824(ROCA-070E04)	41,500 [12.2]	28,550 [8.4]	12,950 [3.8]	11.00	13.50	76	1,200 [566]
	RCQD-4824(ROLA-070E04)	42,500 [12.5]	30,700 [9.0]	11,800 [3.5]	11.00	13.50	76	1,375 [649]
	RCQD-4824(ROLA-115E05)	42,000 [12.3]	29,000 [8.5]	13,000 [3.8]	11.50	14.00	76	1,200 [566]
	RHKL-HM4821(RCSL-H*4821)	42,000 [12.3]	30,000 [8.8]	12,000 [3.5]	11.50	13.50	76	1,400 [661]
	RHLL-HM4821(RCSL-H*4821)	42,000 [12.3]	30,000 [8.8]	12,000 [3.5]	11.50	14.00	76	1,400 [661]
	RHSL-HM4221(RCSL-H*4821)	41,000 [12.0]	28,950 [8.5]	12,050 [3.5]	10.50	13.00	76	1,350 [637]
049CAZ/DAZ/ JAZ/YAZ	RCFL-H*4821 ①	46,500 [13.6]	33,250 [9.7]	13,250 [3.9]	11.00	13.00	76	1,550 [731]
	RCFL-A*4821	46,500 [13.6]	33,250 [9.7]	13,250 [3.9]	11.00	13.00	76	1,550 [731]
	RCFL-A*4821(RGFE-09?ZCM?)	46,500 [13.6]	32,100 [9.4]	14,400 [4.2]	11.00	13.00	76	1,400 [661]
	RCFL-A*4821(RGGE-09?ZCM?)	46,500 [13.6]	32,050 [9.4]	14,450 [4.2]	11.00	13.00	76	1,400 [661]
	RCFL-A*4821(RGGE-10?ZCM?)	46,500 [13.6]	32,100 [9.4]	14,400 [4.2]	11.00	13.00	76	1,400 [661]
	RCFL-A*4821(RGLE-10?BRM?)	47,000 [13.8]	32,450 [9.5]	14,550 [4.3]	11.00	13.50	76	1,400 [661]
	RCFL-A*4821(RGLT-07?BRQ?)	46,500 [13.6]	32,350 [9.5]	14,150 [4.1]	11.00	13.50	76	1,425 [672]
	RCFL-A*4821(RGLT-10?BRM?)	46,000 [13.5]	31,700 [9.3]	14,300 [4.2]	11.00	13.50	76	1,400 [661]
	RCFL-A*4821(RGPE-07?BRQ?)	47,000 [13.8]	32,500 [9.5]	14,500 [4.2]	11.00	13.50	76	1,400 [661]
	RCFL-A*4821(RGPE-10?BRM?)	47,500 [13.9]	34,550 [10.1]	12,950 [3.8]	11.00	13.00	76	1,625 [767]
	RCFL-A*4821(RGPT-07?BRQ?)	46,500 [13.6]	32,300 [9.5]	14,200 [4.2]	11.00	13.50	76	1,425 [672]
	RCFL-A*4821(RGPT-10?BRM?)	46,000 [13.5]	31,650 [9.3]	14,350 [4.2]	11.00	13.50	76	1,400 [661]
	RCFL-A*4821(RGTM-07?RBG?)	46,500 [13.6]	31,500 [9.2]	15,000 [4.4]	11.00	13.50	76	1,325 [625]
	RCFL-A*4821(RGTM-09?ZAJ?)	46,500 [13.6]	32,050 [9.4]	14,450 [4.2]	11.00	13.00	76	1,400 [661]
	RCFL-A*4821(RHWB-04WMMX36A)	45,500 [13.3]	30,700 [9.0]	14,800 [4.3]	11.00	13.00	76	1,300 [613]
	RCFL-A*4821(RHWB-06WMMX48A)	45,500 [13.3]	30,700 [9.0]	14,800 [4.3]	11.00	13.00	76	1,300 [613]
	RCFL-A*4821(ROLA-070E04)	46,000 [13.5]	31,550 [9.2]	14,450 [4.2]	11.00	13.00	76	1,375 [649]
	RCFL-A*4821(ROLA-115E05)	46,000 [13.5]	31,700 [9.3]	14,300 [4.2]	11.00	13.00	76	1,400 [661]
	RCFL-A*4824	46,500 [13.6]	33,250 [9.7]	13,250 [3.9]	11.00	13.00	76	1,550 [731]
	RCFL-A*4824(RGFE-09?ZCM?)	46,500 [13.6]	32,100 [9.4]	14,400 [4.2]	11.00	13.00	76	1,400 [661]
	RCFL-A*4824(RGFE-12?RCM?)	47,000 [13.8]	32,850 [9.6]	14,150 [4.1]	11.00	13.00	76	1,450 [684]
	RCFL-A*4824(RGFG-12?RCM?)	47,000 [13.8]	32,800 [9.6]	14,200 [4.2]	11.00	13.50	76	1,450 [684]
	RCFL-A*4824(RGGE-09?ZCM?)	46,500 [13.6]	32,050 [9.4]	14,450 [4.2]	11.00	13.00	76	1,400 [661]
	RCFL-A*4824(RGGE-10?ZCM?)	46,500 [13.6]	32,100 [9.4]	14,400 [4.2]	11.00	13.00	76	1,400 [661]
	RCFL-A*4824(RGGE-12?RCM?)	47,000 [13.8]	33,550 [9.8]	13,450 [3.9]	11.00	13.00	76	1,575 [743]
	RCFL-A*4824(RGLE-10?BRM?)	47,500 [13.9]	34,350 [10.1]	13,150 [3.9]	11.00	13.50	76	1,600 [755]
	RCFL-A*4824(RGLE-12?ARM?)	47,500 [13.9]	34,350 [10.1]	13,150 [3.9]	11.00	13.50	76	1,600 [755]
	RCFL-A*4824(RGLT-07?BRQ?)	46,500 [13.6]	32,350 [9.5]	14,150 [4.1]	11.00	13.50	76	1,425 [672]
	RCFL-A*4824(RGLT-10?BRM?)	46,000 [13.5]	31,700 [9.3]	14,300 [4.2]	11.00	13.50	76	1,400 [661]
	RCFL-A*4824(RGLT-12?ARM?)	46,000 [13.5]	31,300 [9.2]	14,700 [4.3]	11.00	13.50	76	1,350 [637]
	RCFL-A*4824(RGPE-07?BRQ?)	47,000 [13.8]	32,500 [9.5]	14,500 [4.2]	11.00	13.50	76	1,400 [661]
	RCFL-A*4824(RGPE-10?BRM?)	47,500 [13.9]	34,000 [10.0]	13,500 [4.0]	11.00	13.50	76	1,550 [731]
	RCFL-A*4824(RGPE-12?ARM?)	47,500 [13.9]	34,500 [10.1]	13,000 [3.8]	11.00	13.50	76	1,625 [767]
	RCFL-A*4824(RGPT-07?BRQ?)	46,500 [13.6]	32,300 [9.5]	14,200 [4.2]	11.00	13.50	76	1,425 [672]
	RCFL-A*4824(RGPT-10?BRM?)	46,500 [13.6]	32,300 [9.5]	14,200 [4.2]	11.00	13.50	76	1,425 [672]
	RCFL-A*4824(RGPT-12?ARM?)	46,000 [13.5]	31,300 [9.2]	14,700 [4.3]	11.00	13.50	76	1,350 [637]

① Highest sales volume tested combination required by D.O.E. test procedures.

[] Designates Metric Conversions



Performance Data @ AHRI Standard Conditions—Cooling

Model Numbers		80°F [26.5°C] DB/67°F [19.5°C] WB Indoor Air 95°F [35°C] DB Outdoor Air					Sound Rating dB	Indoor CFM [L/s]
Outdoor Unit RANL-	Indoor Coil and/or Air Handler	Total Capacity BTU/H [kW]	Net Sensible BTU/H [kW]	Net Latent BTU/H [kW]	EER	SEER		
Rev. 5/17/12	RCFL-A*4824(RGTM-07?RBG?)	46,500 [13.6]	31,500 [9.2]	15,000 [4.4]	11.00	13.50	76	1,325 [625]
	RCFL-A*4824(RGTM-09?ZAJ?)	46,500 [13.6]	32,050 [9.4]	14,450 [4.2]	11.00	13.00	76	1,400 [661]
	RCFL-A*4824(RGTM-10?RBJ?)	47,000 [13.8]	32,650 [9.6]	14,350 [4.2]	11.00	13.50	76	1,425 [672]
	RCFL-A*4824(RHWB-08WRX60A)	46,500 [13.6]	32,600 [9.6]	13,900 [4.1]	11.50	13.50	76	1,450 [684]
	RCFL-A*4824(RHWB-10WRX60A)	46,000 [13.5]	31,500 [9.2]	14,500 [4.2]	11.50	14.00	76	1,350 [637]
	RCFL-A*4824(ROLA-070E04)	46,000 [13.5]	31,550 [9.2]	14,450 [4.2]	11.00	13.00	76	1,375 [649]
	RCFL-A*4824(ROLA-115E05)	46,000 [13.5]	31,700 [9.3]	14,300 [4.2]	11.00	13.00	76	1,400 [661]
	RCFL-H*4821(RGFE-09?ZCM?)	46,500 [13.6]	32,100 [9.4]	14,400 [4.2]	11.00	13.00	76	1,400 [661]
	RCFL-H*4821(RGGE-09?ZCM?)	46,500 [13.6]	32,050 [9.4]	14,450 [4.2]	11.00	13.00	76	1,400 [661]
	RCFL-H*4821(RGGE-10?ZCM?)	46,500 [13.6]	32,100 [9.4]	14,400 [4.2]	11.00	13.00	76	1,400 [661]
	RCFL-H*4821(RGJF-09?ZCM?)	46,500 [13.6]	32,050 [9.4]	14,450 [4.2]	11.00	13.00	76	1,400 [661]
	RCFL-H*4821(RGJF-10?ZCM?)	46,500 [13.6]	32,100 [9.4]	14,400 [4.2]	11.00	13.00	76	1,400 [661]
	RCFL-H*4821(RGLE-10?BRM?)	47,500 [13.9]	34,350 [10.1]	13,150 [3.9]	11.00	13.50	76	1,600 [755]
	RCFL-H*4821(RGLT-07?BRQ?)	46,500 [13.6]	32,350 [9.5]	14,150 [4.1]	11.00	13.50	76	1,425 [672]
	RCFL-H*4821(RGLT-10?BRM?)	46,000 [13.5]	31,700 [9.3]	14,300 [4.2]	11.00	13.50	76	1,400 [661]
	RCFL-H*4821(RGPE-07?BRQ?)	47,500 [13.9]	34,400 [10.1]	13,100 [3.8]	11.00	13.00	76	1,600 [755]
	RCFL-H*4821(RGPE-10?BRM?)	47,500 [13.9]	34,000 [10.0]	13,500 [4.0]	11.00	13.50	76	1,550 [731]
	RCFL-H*4821(RGPT-07?BRQ?)	46,500 [13.6]	32,300 [9.5]	14,200 [4.2]	11.00	13.50	76	1,425 [672]
	RCFL-H*4821(RGPT-10?BRM?)	46,500 [13.6]	32,300 [9.5]	14,200 [4.2]	11.00	13.50	76	1,425 [672]
	RCFL-H*4821(RGTM-07?RBG?)	46,500 [13.6]	31,500 [9.2]	15,000 [4.4]	11.00	13.50	76	1,325 [625]
	RCFL-H*4821(RGTM-09?ZAJ?)	46,500 [13.6]	32,050 [9.4]	14,450 [4.2]	11.00	13.00	76	1,400 [661]
	RCFL-H*4821(RHWB-04WMX36A)	45,500 [13.3]	30,700 [9.0]	14,800 [4.3]	11.00	13.00	76	1,300 [613]
	RCFL-H*4821(RHWB-06WMX48A)	45,500 [13.3]	30,700 [9.0]	14,800 [4.3]	11.00	13.00	76	1,300 [613]
049CAZ/DAZ/ JAZ/YAZ	RCFL-H*4821(ROLA-070E04)	46,000 [13.5]	31,550 [9.2]	14,450 [4.2]	11.00	13.00	76	1,375 [649]
	RCFL-H*4821(ROLA-115E05)	46,000 [13.5]	31,700 [9.3]	14,300 [4.2]	11.00	13.00	76	1,400 [661]
	RCFL-H*4824	46,500 [13.6]	33,250 [9.7]	13,250 [3.9]	11.00	13.00	76	1,550 [731]
	RCFL-H*4824(RGFE-09?ZCM?)	46,500 [13.6]	32,100 [9.4]	14,400 [4.2]	11.00	13.00	76	1,400 [661]
	RCFL-H*4824(RGFE-12?RCM?)	47,000 [13.8]	32,850 [9.6]	14,150 [4.1]	11.00	13.00	76	1,450 [684]
	RCFL-H*4824(RGFG-12?RCM?)	47,000 [13.8]	32,600 [9.6]	14,400 [4.2]	11.00	13.50	76	1,450 [684]
	RCFL-H*4824(RGGE-09?ZCM?)	46,500 [13.6]	32,050 [9.4]	14,450 [4.2]	11.00	13.00	76	1,400 [661]
	RCFL-H*4824(RGGE-10?ZCM?)	46,500 [13.6]	32,100 [9.4]	14,400 [4.2]	11.00	13.00	76	1,400 [661]
	RCFL-H*4824(RGGE-12?RCM?)	47,000 [13.8]	33,550 [9.8]	13,450 [3.9]	11.00	13.00	76	1,575 [743]
	RCFL-H*4824(RGJF-09?ZCM?)	46,500 [13.6]	32,050 [9.4]	14,450 [4.2]	11.00	13.00	76	1,400 [661]
	RCFL-H*4824(RGJF-10?ZCM?)	46,500 [13.6]	32,100 [9.4]	14,400 [4.2]	11.00	13.00	76	1,400 [661]
	RCFL-H*4824(RGJF-12?RCM?)	47,000 [13.8]	33,550 [9.8]	13,450 [3.9]	11.00	13.00	76	1,575 [743]
	RCFL-H*4824(RGLE-10?BRM?)	47,500 [13.9]	34,350 [10.1]	13,150 [3.9]	11.00	13.50	76	1,600 [755]
	RCFL-H*4824(RGLE-12?ARM?)	47,500 [13.9]	34,350 [10.1]	13,150 [3.9]	11.00	13.50	76	1,600 [755]
	RCFL-H*4824(RGLT-07?BRQ?)	46,500 [13.6]	32,350 [9.5]	14,150 [4.1]	11.00	13.50	76	1,425 [672]
	RCFL-H*4824(RGLT-10?BRM?)	46,000 [13.5]	31,700 [9.3]	14,300 [4.2]	11.00	13.50	76	1,400 [661]
	RCFL-H*4824(RGLT-12?ARM?)	46,000 [13.5]	31,300 [9.2]	14,700 [4.3]	11.00	13.50	76	1,350 [637]
	RCFL-H*4824(RGPE-07?BRQ?)	47,500 [13.9]	34,400 [10.1]	13,100 [3.8]	11.00	13.00	76	1,600 [755]
	RCFL-H*4824(RGPE-10?BRM?)	47,500 [13.9]	34,550 [10.1]	12,950 [3.8]	11.00	13.00	76	1,625 [767]
	RCFL-H*4824(RGPE-12?ARM?)	47,500 [13.9]	34,500 [10.1]	13,000 [3.8]	11.00	13.50	76	1,625 [767]
	RCFL-H*4824(RGPT-07?BRQ?)	46,500 [13.6]	32,300 [9.5]	14,200 [4.2]	11.00	13.50	76	1,425 [672]
	RCFL-H*4824(RGPT-10?BRM?)	46,500 [13.6]	32,300 [9.5]	14,200 [4.2]	11.00	13.50	76	1,425 [672]
	RCFL-H*4824(RGPT-12?ARM?)	46,000 [13.5]	31,300 [9.2]	14,700 [4.3]	11.00	13.50	76	1,350 [637]
	RCFL-H*4824(RGTM-07?RBG?)	46,500 [13.6]	31,650 [9.3]	14,850 [4.4]	11.50	14.00	76	1,325 [625]
	RCFL-H*4824(RGTM-09?ZAJ?)	46,500 [13.6]	32,200 [9.4]	14,300 [4.2]	11.00	13.50	76	1,400 [661]
	RCFL-H*4824(RGTM-10?RBJ?)	47,000 [13.8]	32,850 [9.6]	14,150 [4.1]	11.00	13.50	76	1,425 [672]

① Highest sales volume tested combination required by D.O.E. test procedures.

[] Designates Metric Conversions



Performance Data @ AHRI Standard Conditions—Cooling

Model Numbers		80°F [26.5°C] DB/67°F [19.5°C] WB Indoor Air 95°F [35°C] DB Outdoor Air					Sound Rating dB	Indoor CFM [L/s]
Outdoor Unit RANL-	Indoor Coil and/or Air Handler	Total Capacity BTU/H [kW]	Net Sensible BTU/H [kW]	Net Latent BTU/H [kW]	EER	SEER		
Rev. 5/17/12	RCFL-H*4824(RHWP-08WRX60A)	46,500 [13.6]	32,600 [9.6]	13,900 [4.1]	11.50	13.50	76	1,450 [684]
	RCFL-H*4824(RHWP-10WRX60A)	46,000 [13.5]	31,500 [9.2]	14,500 [4.2]	11.50	14.00	76	1,350 [637]
	RCFL-H*4824(ROLA-070E04)	46,000 [13.5]	31,550 [9.2]	14,450 [4.2]	11.00	13.00	76	1,375 [649]
	RCFL-H*4824(ROLA-115E05)	46,000 [13.5]	31,700 [9.3]	14,300 [4.2]	11.00	13.00	76	1,400 [661]
	RBHP-24(RCHL-48A1)	45,500 [13.3]	31,300 [9.2]	14,200 [4.2]	11.00	13.00	76	1,600 [755]
	RCQD-4821(RGFG-09?ZCM?)	46,500 [13.6]	32,700 [9.6]	13,800 [4.0]	11.00	13.50	76	1,400 [661]
	RCQD-4821(RGFG-10?ZCM?)	46,500 [13.6]	32,700 [9.6]	13,800 [4.0]	11.00	13.00	76	1,400 [661]
	RCQD-4821(RGPT-07?BRQ?)	47,500 [13.9]	33,250 [9.7]	14,250 [4.2]	11.50	14.00	76	1,425 [672]
	RCQD-4821(RGPT-10?BRM?)	47,500 [13.9]	33,200 [9.7]	14,300 [4.2]	11.50	14.00	76	1,425 [672]
	RCQD-4821(RHWP-04WMMX36A)	46,500 [13.6]	32,100 [9.4]	14,400 [4.2]	11.50	13.50	76	1,300 [613]
	RCQD-4821(RHWP-06WMMX48A)	46,500 [13.6]	32,300 [9.5]	14,200 [4.2]	11.50	13.50	76	1,325 [625]
	RCQD-4821(ROLA-070E04)	46,500 [13.6]	31,550 [9.2]	14,950 [4.4]	11.00	13.50	76	1,375 [649]
	RCQD-4821A*	47,000 [13.8]	34,250 [10.0]	12,750 [3.7]	11.00	13.00	76	1,600 [755]
	RCQD-4821A*(RGFD-12?RCM?)	47,500 [13.9]	35,050 [10.3]	12,450 [3.6]	11.00	13.00	76	1,650 [779]
	RCQD-4824(RGFE-09?ZCM?)	47,000 [13.8]	32,650 [9.6]	14,350 [4.2]	11.00	13.50	76	1,400 [661]
	RCQD-4824(RGFE-10?ZCM?)	47,000 [13.8]	32,850 [9.6]	14,150 [4.1]	11.00	13.50	76	1,425 [672]
	RCQD-4824(RGFE-12?RCM?)	47,500 [13.9]	33,400 [9.8]	14,100 [4.1]	11.50	14.00	76	1,450 [684]
	RCQD-4824(RGFG-09?ZCM?)	46,500 [13.6]	32,650 [9.6]	13,850 [4.1]	11.50	13.50	76	1,400 [661]
	RCQD-4824(RGFG-10?ZCM?)	46,500 [13.6]	32,650 [9.6]	13,850 [4.1]	11.50	13.50	76	1,400 [661]
	RCQD-4824(RGFG-12?RCM?)	47,000 [13.8]	33,400 [9.8]	13,600 [4.0]	11.50	13.50	76	1,450 [684]
	RCQD-4824(RGJF-09?ZCM?)	47,000 [13.8]	32,600 [9.6]	14,400 [4.2]	11.50	13.50	76	1,400 [661]
	RCQD-4824(RGJF-10?ZCM?)	47,000 [13.8]	32,650 [9.6]	14,350 [4.2]	11.00	13.50	76	1,400 [661]
	RCQD-4824(RGJF-12?RCM?)	48,000 [14.1]	34,950 [10.2]	13,050 [3.8]	11.50	13.50	76	1,575 [743]
	RCQD-4824(RGPE-07?BRQ?)	48,000 [14.1]	34,950 [10.2]	13,050 [3.8]	11.50	13.50	76	1,600 [755]
	RCQD-4824(RGPE-10?BRM?)	48,000 [14.1]	34,950 [10.2]	13,050 [3.8]	11.50	13.50	76	1,625 [767]
	RCQD-4824(RGPE-12?ARM?)	48,000 [14.1]	34,900 [10.2]	13,100 [3.8]	11.50	13.50	76	1,625 [767]
	RCQD-4824(RGPT-07?BRQ?)	47,500 [13.9]	33,550 [9.8]	13,950 [4.1]	11.50	14.00	76	1,475 [696]
	RCQD-4824(RGPT-10?BRM?)	47,500 [13.9]	33,350 [9.8]	14,150 [4.1]	11.50	14.00	76	1,450 [684]
	RCQD-4824(RGPT-12?ARM?)	47,500 [13.9]	33,000 [9.7]	14,500 [4.2]	11.50	14.00	76	1,400 [661]
	RCQD-4824(RHWP-08WRX60A)	47,000 [13.8]	33,850 [9.9]	13,150 [3.9]	11.50	14.00	76	1,475 [696]
	RCQD-4824(RHWP-10WRX60A)	47,000 [13.8]	33,550 [9.8]	13,450 [3.9]	11.50	14.00	76	1,425 [672]
	RCQD-4824(ROCA-070E04)	47,000 [13.8]	32,700 [9.6]	14,300 [4.2]	11.00	13.00	76	1,400 [661]
	RCQD-4824(ROLA-070E04)	47,000 [13.8]	32,400 [9.5]	14,600 [4.3]	11.50	14.00	76	1,375 [649]
	RCQD-4824(ROLA-115E05)	47,500 [13.9]	33,800 [9.9]	13,700 [4.0]	11.00	13.50	76	1,500 [708]
	RCQD-4824A*(RGFD-12?RCM?)	47,500 [13.9]	35,050 [10.3]	12,450 [3.6]	11.00	13.00	76	1,650 [779]
	RHKL-HM4821(RCSL-H*4821)	47,000 [13.8]	33,650 [9.9]	13,350 [3.9]	11.50	13.50	76	1,575 [743]
RHLL-HM4821(RCSL-H*4821)	47,000 [13.8]	33,950 [9.9]	13,050 [3.8]	11.50	13.50	76	1,600 [755]	
RHSL-HM4821(RCSL-H*4821)	46,500 [13.6]	33,250 [9.7]	13,250 [3.9]	11.00	13.00	76	1,525 [720]	
RHKL-HM4824(RCSL-H*4824)	48,500 [14.2]	36,500 [10.7]	12,000 [3.5]	11.50	14.00	76	1,625 [767]	
RHLL-HM4824(RCSL-H*4824)	48,500 [14.2]	36,450 [10.7]	12,050 [3.5]	11.50	14.00	76	1,625 [767]	
RHSL-HM4824(RCSL-H*4824)	47,500 [13.9]	35,000 [10.3]	12,500 [3.7]	11.00	13.00	76	1,525 [720]	
060CAZ/DAZ/JAZ/YAZ	RCFL-H*6024 ①	61,000 [17.9]	42,900 [12.6]	18,100 [5.3]	11.00	13.00	76	1,800 [849]
	RCFL-A*6024	61,000 [17.9]	42,900 [12.6]	18,100 [5.3]	11.00	13.00	76	1,800 [849]
	RCFL-H*6024(RHWP-08WRX60A)	60,000 [17.6]	40,700 [11.9]	19,300 [5.7]	11.00	13.00	76	1,650 [779]
	RCFL-H*6024(RHWP-10WRX60A)	60,000 [17.6]	41,300 [12.1]	18,700 [5.5]	11.00	13.00	76	1,700 [802]
	RBHP-25(RCHL-60A1)	55,500 [16.3]	36,600 [10.7]	18,900 [5.5]	10.50	13.00	76	1,800 [849]
	RCQD-6024	58,500 [17.1]	40,250 [11.8]	18,250 [5.3]	10.50	13.00	76	1,800 [849]
	RHKL-HM6024(RCSL-H*6024)	62,000 [18.2]	43,450 [12.7]	18,550 [5.4]	11.50	13.50	76	1,800 [849]
	RHLL-HM6024(RCSL-H*6024)	62,000 [18.2]	43,500 [12.7]	18,500 [5.4]	11.50	13.50	76	1,800 [849]

① Highest sales volume tested combination required by D.O.E. test procedures.

[] Designates Metric Conversions



Electrical and Physical Data

Model Number RANL-	ELECTRICAL							PHYSICAL					
	Phase Frequency (Hz) Voltage (Volts)	Compressor		Fan Motor Full Load Amperes (FLA)	Minimum Circuit Ampacity Amperes	Fuse or HACR Circuit Breaker		Outdoor Coil			Refrig. Per Circuit Oz. [g]	Weight	
		Rated Load Amperes (RLA)	Locked Rotor Amperes (LRA)			Minimum Amperes	Maximum Amperes	Face Area Sq. Ft. [m ²]	No. Rows	CFM [L/s]		Net Lbs. [kg]	Shipping Lbs. [kg]
Rev. 5/17/12													
018JAZ	1-60-208/230	9/9	48	0.6	12/12	15/15	20/20	9.07 [0.84]	1	1775 [838]	70 [1984]	130 [59.0]	140 [59]
024JAZ	1-60-208/230	12.8/12.8	58.3	0.6	17/17	20/20	25/25	11.00 [1.02]	1	1920 [906]	72 [2041]	140 [63.5]	150 [63.5]
031JAZ	1-60-208/230	14.1/14.1	73	0.6	19/19	25/25	30/30	11.06 [1.03]	1	1920 [906]	83 [2353]	143 [64.9]	152.5 [64.9]
037CAZ	3-60-208/230	13.2/13.2	88	1.2	18/18	25/25	30/30	16.10 [1.50]	1	3200 [1510]	106 [3005]	193 [87.5]	211.5 [87.5]
037DAZ	3-60-460	6	44	0.6	9	15	15	16.10 [1.50]	1	3200 [1510]	106 [3005]	193 [87.5]	211.5 [87.5]
037JAZ	1-60-208/230	17.9/17.9	112	1.2	24/24	30/30	40/40	16.10 [1.50]	1	3200 [1510]	106 [3005]	193 [87.5]	211.5 [87.5]
043CAZ	3-60-208/230	13.6/13.6	83.1	1.2	19/19	25/25	30/30	16.10 [1.50]	1	3200 [1510]	115 [3260]	202 [91.6]	210.5 [91.6]
043DAZ	3-60-460	6.1	41	0.6	9	15	15	16.10 [1.50]	1	3200 [1510]	115 [3260]	202 [91.6]	210.5 [91.6]
043JAZ	1-60-208/230	19.9/19.9	109	1.2	27/27	35/35	45/45	16.10 [1.50]	1	3200 [1510]	115 [3260]	202 [91.6]	210.5 [91.6]
049CAZ	3-60-208/230	13.7/13.7	83.1	1.2	19/19	25/25	30/30	20.13 [1.87]	1	3500 [1652]	132 [3742]	214 [97.1]	233.5 [97.1]
049DAZ	3-60-460	6.2	41	0.6	9	15	15	23.13 [2.15]	1	3500 [1652]	132 [3742]	214 [97.1]	233.5 [97.1]
049JAZ	1-60-208/230	21.8/21.8	117	1.2	29/29	35/35	50/50	20.13 [1.87]	1	3500 [1652]	132 [3742]	214 [97.1]	233.5 [97.1]
049YAZ	3-60-575	4.8	33	0.5	7	15	15	20.13 [1.87]	1	3500 [1652]	132 [3742]	214 [97.1]	233.5 [97.1]
060CAZ	3-60-208/230	15.6/15.6	110	1.2	21/21	25/25	35/35	23.01 [2.14]	1	3500 [1652]	180 [5103]	250 [113.4]	260 [113.4]
060DAZ	3-60-460	7.8	52	0.6	11	15	15	23.01 [2.14]	1	3500 [1652]	180 [5103]	250 [113.4]	260 [113.4]
060JAZ	1-60-208/230	26.3/26.3	134	1.2	35/35	45/45	60/60	23.01 [2.14]	1	3500 [1652]	180 [5103]	250 [113.4]	260 [113.4]
060YAZ	3-60-575	5.8	38.9	0.5	8	15	15	23.01 [2.14]	1	3500 [1652]	180 [5103]	250 [113.4]	260 [113.4]

[] Designates Metric Conversions

Unit Dimensions

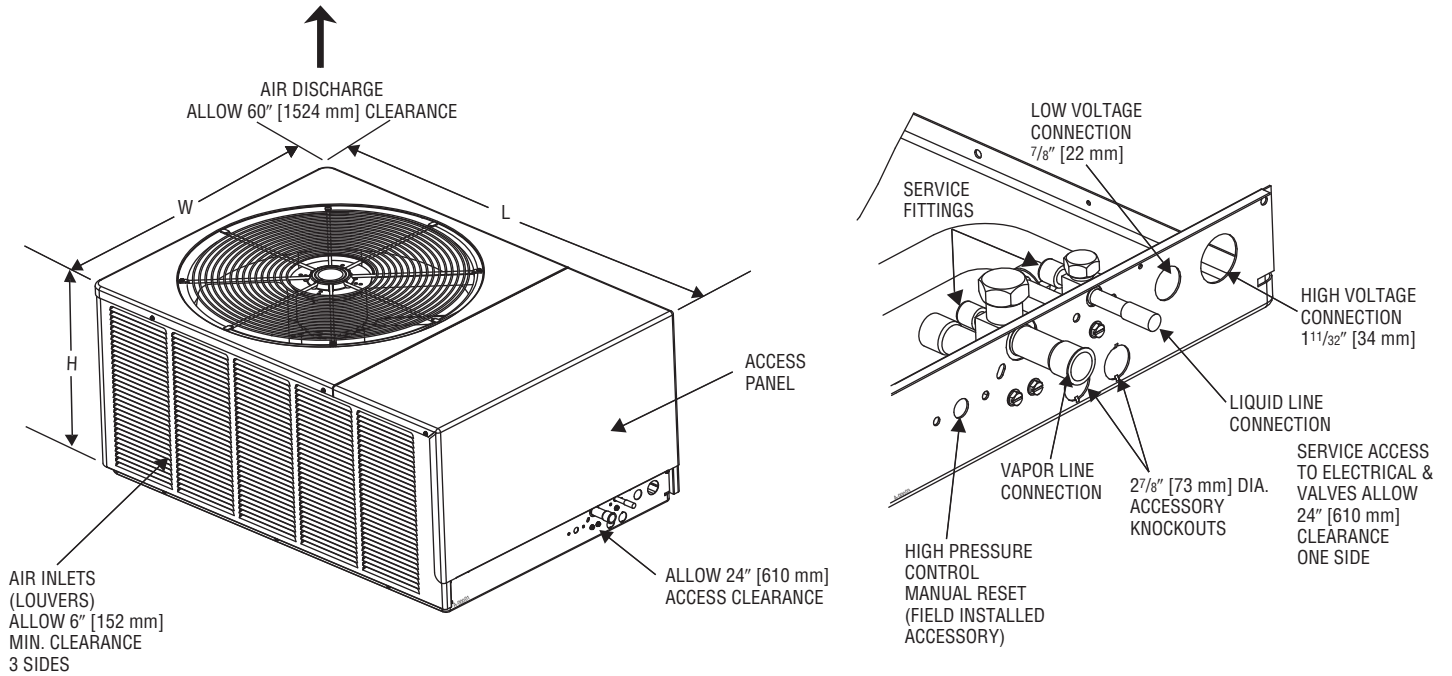

Model Number RANL-	Height "H" (Inches) [mm]	Length "L" (Inches) [mm]	Width "W" (Inches) [mm]
018	19 [483]	35 1/2 [902]	23 3/4 [603]
024/031	19 [483]	40 1/2 [1029]	27 5/8 [702]
037/043	23 [584]	44 3/8 [1127]	31 1/2 [800]
049	29 [737]	44 3/8 [1127]	31 1/2 [800]
060	33 [838]	44 3/8 [1127]	31 1/2 [800]

[] Designates Metric Conversions

Condensing Unit Refrigerant Line Size Information

Liquid Line Sizing (R-410A)														
System Capacity	Line Size Connection (Inch I.D.)	Line Size (Inch O.D.) [mm]	Liquid Line Size – Outdoor Unit Above Indoor Coil (Cooling Only – Does not apply to Heat Pumps)						Liquid Line Size – Outdoor Unit Below Indoor Coil					
			Total Equivalent Length—Feet [m]						Total Equivalent Length—Feet [m]					
			25 [7.62]	50 [15.24]	75 [22.86]	100 [30.48]	125 [38.10]	150 [45.72]	25 [7.62]	50 [15.24]	75 [22.86]	100 [30.48]	125 [38.10]	150 [45.72]
			Minimum Vertical Separation—Feet [m]						Maximum Vertical Separation—Feet [m]					
1½ Ton	3/8"	1/4 [6.35]	0	0	0	0	8 [2.44]	24 [7.32]	25 [7.62]	40 [12.19]	25 [7.62]	9 [2.74]	N/A	N/A
		5/16 [7.94]	0	0	0	0	0	0	25 [7.62]	50 [15.24]	62 [18.90]	58 [17.68]	53 [16.15]	49 [14.94]
		3/8* [9.53]	0	0	0	0	0	0	25 [7.62]	50 [15.24]	75 [22.86]	72 [21.95]	70 [21.34]	68 [20.73]
2 Ton	3/8"	1/4 [6.35]	0	3 [0.91]	29 [8.84]	55 [16.76]	81 [24.69]	108 [32.92]	23 [7.01]	N/A	N/A	N/A	N/A	N/A
		5/16 [7.94]	0	0	0	0	0	0	25 [7.62]	36 [10.97]	29 [8.84]	23 [7.01]	16 [4.88]	9 [2.74]
		3/8* [9.53]	0	0	0	0	0	0	25 [7.62]	50 [15.24]	72 [21.95]	70 [21.34]	68 [20.73]	65 [19.81]
2½ Ton	3/8"	1/4 [6.35]	0	14 [4.27]	56 [17.07]	98 [29.87]	N/A	N/A	25 [7.62]	N/A	N/A	N/A	N/A	N/A
		5/16 [7.94]	0	0	0	0	0	0	25 [7.62]	49 [14.94]	38 [11.58]	27 [8.23]	17 [5.18]	6 [1.83]
		3/8* [9.53]	0	0	0	0	0	0	25 [7.62]	50 [15.24]	68 [20.73]	65 [19.81]	62 [18.90]	58 [17.68]
3 Ton	3/8"	5/16 [7.94]	0	0	0	0	0	9 [2.74]	25 [7.62]	50 [15.24]	37 [11.28]	22 [6.71]	7 [2.13]	N/A
		3/8* [9.53]	0	0	0	0	0	0	25 [7.62]	50 [15.24]	68 [20.73]	63 [19.20]	58 [17.68]	53 [16.15]
3½ Ton	3/8"	5/16 [7.94]	0	0	0	16 [4.88]	35 [10.67]	54 [16.46]	25 [7.62]	23 [7.01]	4 [1.22]	N/A	N/A	N/A
		3/8* [9.53]	0	0	0	0	0	0	25 [7.62]	50 [15.24]	43 [13.11]	36 [10.97]	30 [9.14]	24 [7.32]
4 Ton	3/8"	3/8* [9.53]	0	0	0	0	0	0	25 [7.62]	46 [14.02]	38 [11.58]	30 [9.14]	22 [6.71]	15 [4.57]
		1/2 [12.57]	0	0	0	0	0	0	25 [7.62]	50 [15.24]	56 [17.07]	55 [16.76]	53 [16.15]	52 [15.85]
5 Ton	3/8"	3/8* [9.53]	0	0	0	0	0	0	25 [7.62]	50 [15.24]	56 [17.07]	44 [13.41]	32 [9.75]	20 [6.10]
		1/2 [12.57]	0	0	0	0	0	0	25 [7.62]	50 [15.24]	75 [22.86]	81 [24.69]	79 [24.08]	76 [23.16]

NOTES: *Standard line size
N/A = Application not recommended.

Suction Line Length/Size versus Capacity Multiplier (R-410A)								
Unit Size	1½ Ton	2 Ton	2½ Ton	3 Ton	3½ Ton	4 Ton	5 Ton	
Suction Line Connection Size	¾" [19.05 mm] I.D.				7/8" [22.23 mm] I.D.			
Suction Line Run—Feet [m]	5/8" [15.88 mm] O.D. Opt. ¾" [19.05 mm] O.D. Std.*		5/8" [15.88 mm] O.D. Opt. ¾" [19.05 mm] O.D. Std.* 7/8" [22.23 mm] O.D. Opt.		¾" [19.05 mm] O.D. Opt. 7/8" [22.23 mm] O.D. Std.*		7/8" [22.23 mm] O.D. Opt. 1" [25.4 mm] O.D. Std.*	
25' [7.62]	Optional Standard Optional	1.00 1.00 N/A	1.00 1.00 N/A	1.00 1.00 1.00	1.00 1.00 N/A	1.00 1.00 N/A	1.00 1.00 N/A	1.00 1.00 N/A
50' [15.24]	Optional Standard Optional	.98 .99 N/A	.98 .99 N/A	.96 .98 .99	.98 .99 N/A	.99 .99 N/A	.99 .99 N/A	.99 .99 N/A
100' [30.48]	Optional Standard Optional	.95 .96 N/A	.95 .96 N/A	.94 .96 .97	.96 .97 N/A	.96 .98 N/A	.96 .98 N/A	.97 .98 N/A
150' [45.72]	Optional Standard Optional	.92 .93 N/A	.92 .94 N/A	.91 .93 .95	.94 .95 N/A	.94 .96 N/A	.95 .96 N/A	.94 .97 N/A

NOTES: *Standard line size
Using suction line larger than shown in chart will result in poor oil return and is not recommended.

[] Designates Metric Conversions

GENERAL TERMS OF LIMITED WARRANTY*

Rheem will furnish a replacement for any part of this product which fails in normal use and service within the applicable period stated, in accordance with the terms of the limited warranty.

***For complete details of the Limited and Conditional Warranties, including applicable terms and conditions, contact your local contractor or the Manufacturer for a copy of the product warranty certificate.**

Conditional Parts
(Registration Required)Ten (10) Years



The new degree of comfort.™

In keeping with its policy of continuous progress and product improvement, Rheem reserves the right to make changes without notice.

Rheem Heating, Cooling & Water Heating • P.O. Box 17010
Fort Smith, Arkansas 72917 • www.rheem.com

Rheem Canada Ltd./Ltée • 125 Edgeware Road, Unit 1
Brampton, Ontario • L6Y 0P5



INTEGRATED HOME COMFORT

PRINTED IN U.S.A 12/12 QG FORM NO. A11-216