

User's Manual

Model: BTS-51

Bluetooth Speaker

(Splash-proof)

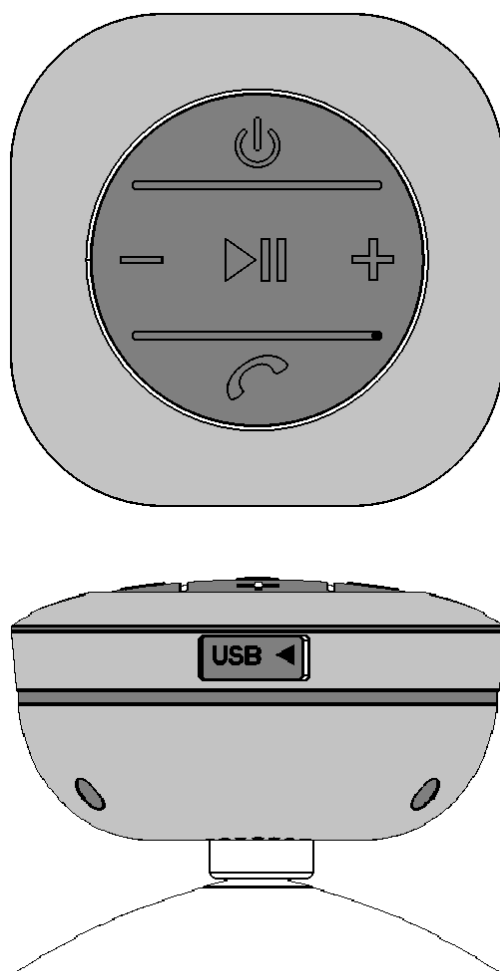

A. Important

Don'ts

- Do not place naked flames, such as lighted candles on or near the product.
- Do not place objects filled with liquids, such as vases on or near the product.
- Do not use or store this product in a place where it is subject to direct sunlight, heat, excessive dust or vibration.
- Do not keep or store this product in wet conditions for long period.
- Do not clean this product with water or other liquids.
- Do not block or cover the slots and holes in the product.
- Do not push foreign objects into the slots or holes in the product.
- Do not attempt to open this product yourself. There are no user serviceable parts inside.
- Do not allow children access to plastic bags.

Safety Instructions

- Before using this product, read and follow all warnings and instructions.
- This product is not intended for use by young children. Young children should be properly supervised.
- This product is intended for household use only and not for commercial or industrial use.
- Do not expose to dripping or splashing.
- No naked flame sources, such as lighted candles, should be placed on the product.
- Ventilation should not be impeded by covering ventilation openings with items such as newspapers, table cloths, curtains and the like.
- Make sure the unit is adjusted to a stable position. Damage caused by using this product in an unstable position or by failure to follow any other warning or precaution contained within this user manual will not be covered by warranty.



Warning

- Never remove the casing of this apparatus.
- Never place this apparatus on the other electrical equipment.

Notice

- If at any time in the future you should need to dispose of this product please note that: All batteries and accumulators need to be removed from this product (Removal of Waste Batteries and Accumulators).
- Always bring your product to a professional to remove the built-in battery.

B. Outlook and Controls

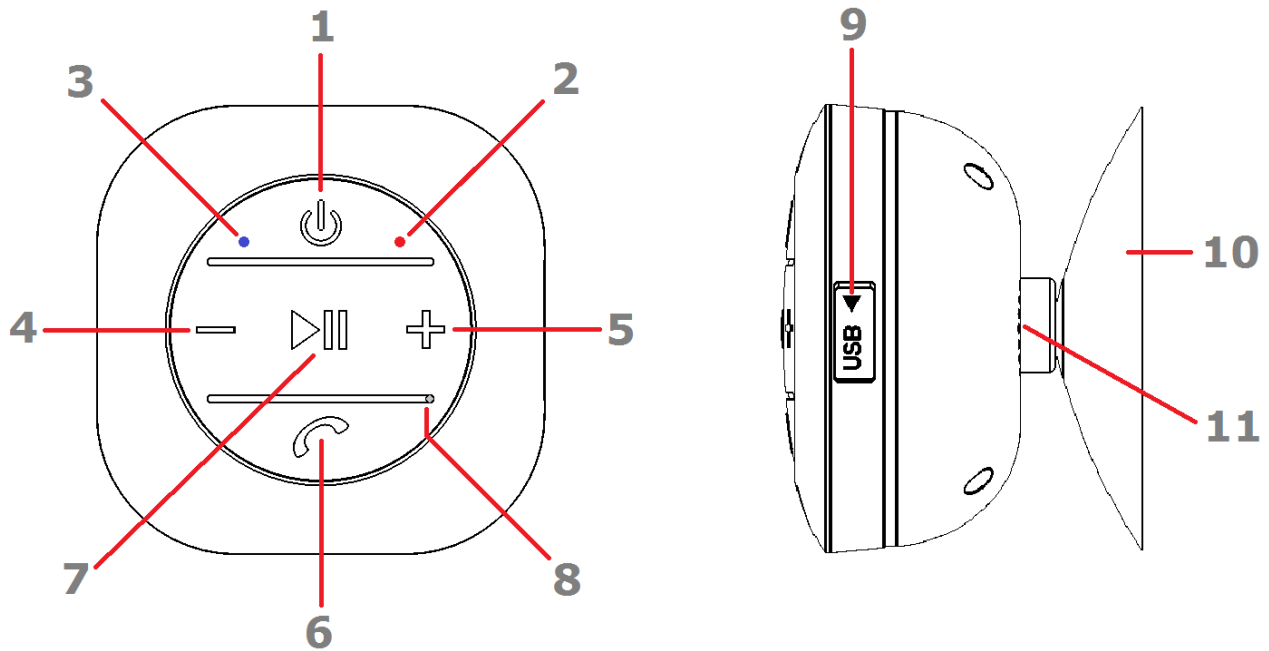

Item	Control
1	⏻ Button (ON / OFF)
2	Charge LED Indicator
3	Bluetooth LED Indicator (Blue)
4	— Button
5	+ Button
6	☎ Button
7	▶ Button
8	MIC Hole
9	Micro USB socket (Under Rubber Seal Cover)
10	Vacuum Cupule
11	Speaker

C. About the rechargeable Battery & Charging

- Regarding the lithium rechargeable battery
 - This Bluetooth Speaker has an internal, non-user-replaceable battery. For best results, the first time you use this Bluetooth Speaker, let it charge for about 2 ~ 3 hours or until the “**Charge LED (2)**” Indicator light from On to off which show you the battery is fully charged.
 - For maintain the battery life and performance, if speaker isn’t used for a while, the battery might need to be recharged. Charge the battery at least once every month.
- To recharge the built-in battery:
 - Connect the Bluetooth Speaker’s “**Micro USB socket (9)**” with the Computer’s USB port through USB cable.
 - The “**Charge LED (2)**” Indicator will turn On in red, the battery is in charging.

- The **“Charge LED (2)”** Indicator will turn Off when the rechargeable battery is fully charged.
- Disconnect the USB cable when it is done.

D. Power ON and Pairing

1. Press and hold the **“⏻ (1)”** button to turn On the device. A series of tones will sound, followed by voice announce **“It is pairing waiting for device connecting”** from speaker. And the **“Bluetooth LED (3)”** indicator is fast blinking in Blue.
2. Then activate the Bluetooth function in your mobile device (such as Mobile Phone or Personal Computer), the device will enter to Bluetooth searching mode automatically, if not, tap the relate selection to manually enter to searching mode. (refer to your device’s manual when necessary)
3. Your mobile device should show **‘BTS-51’** in list, and then select it for pairing. Waiting for some seconds and you will see connected message as shown on your mobile device. (For some Bluetooth devices, you may need to input **“0000”** as pairing password)
4. If pairing is successful, voices announce **“paired”** from speakers, and the **“Bluetooth LED (3)”** indicator will slow blinking each 3 ~ 4 seconds once.
5. Now, you can start to music play from the mobile device by it music player program.
6. Press and hold the **“⏻ (1)”** button to turn Off the device when it is not in use.

Note: the device will turn Off automatically in about 8 minutes when there have not Bluetooth connected phone at placed.

E. Disconnect from paired device

1. Press and hold the **“▶|| (7)”** button to switch to new **“Searching / Pairing”** mode, the paired device will disconnect.
2. Or, you can choose **“Disconnect”** from Bluetooth paired device list on your mobile device.
3. In this case; the Bluetooth Speaker will turn back into **“Searching / Pairing”** mode in seconds, a series of tones will sound and the **“Bluetooth LED (3)”** indicator will fast blinking in Blue from slow.
4. Now, you can process for new mobile device pair or power Off the Bluetooth Speaker as you wanted.

F. Auto re-connect with paired device and New pairing

1. Every time you turn On the Bluetooth speaker power; it will firstly searching for the mobile device, which has been paired previously

and still in record. The Bluetooth Speaker will re-connect this mobile device as priority if it is in Bluetooth searching device mode.

2. If not found in some seconds, the Bluetooth Speaker then is turn into new pairing mode internally.
3. Now you can process for new mobile device pair. (refer to item D.2~6 methods)

G. Bluetooth Music Playing Control Function

1. In playing music, press “▶|| (7)” button to pause the music. To resume the music press it again.
2. Press and hold the “+ (5)” button to increases the volume level.
3. Press and hold the “- (4)” button to decreases the volume level.
4. When maximum or minimum volume is reached, a series of tones will sound.
5. Press once the “+ (5)” button to go to next music.
6. Press once the “- (4)” button to go to previous music.

H. Hand Free Function

1. When there is an incoming call during Bluetooth music playing mode;
2. The ringing sound and /or voice announce “**Call Incoming**” will up and the playing music will pause automatically if it is in music play.
3. Press “☎ (6)” button to pick up the call if you want.
4. Now you have hand free function with the Bluetooth speaker.
5. Press “☎ (6)” button again to hang up the call when finished. And,
6. The paused music will start to play automatically.
7. Press and hold “☎ (6)” button for 3 seconds to ignore the incoming call.

Tip: speak to the “**MIC (8)**” hole direct with distance in 30 ~ 60cm to get the best speakerphone performance when necessary.

I. Redial For Last Call Function

1. To redial for last called number by the Bluetooth Speaker, even it is in music playing mode.
2. Press twice the “☎ (6)” button to enter into redial function, the playing will pause and switch to hand free function for redial.
3. Press the “☎ (6)” button again to hang up the redial call.
4. Make sure that your mobile phone has have last dial call used, if not, the redial for last call function cannot be activated.

J. Low Power Reminder And Auto Sleep

1. The Bluetooth Speaker will send announcement “**Low battery please recharge**” out from speaker by every minute. When you heard this reminder, please connect the device to the USB power for charging, if

you still want to use the device.

2. If not, the Bluetooth Speaker will power Off automatically when the battery is keeping low energy level in some minutes.
3. In this case, the device cannot be turned On, until you recharging the battery at least 10 ~ 15 minutes, because the rechargeable battery has not enough energy.

K. Reset the device

1. In some circumstances the device’s function may hanging and need to reset. To reset the Bluetooth speaker;
2. Press and hold the “- (4)” button and “+ (5)” button at the same time. The device is reset and will turn Off automatically.
3. After that turn On the Bluetooth Speaker by press and hold the “⏻ (1)” button.

Important: Do not reset the device if it is proper working.

L. Splash Proof Handling

1. The Bluetooth Speaker can handle a brief jet of water on its surface (IPX4 water resistant). However, it should never be operated under running water and under no circumstance it should never be fully immersed in water. Before use the Shower Bluetooth speaker in bathroom, make sure that the splash proof “**Rubber Seal Cover (9)**” it tighten closed at the right position.
2. After used in bathroom, always wipe the outside of the cabinet thoroughly if it becomes wet with moisture or water splashes. This will help to prevent the internal parts of the unit from entry of water and possible moisture damage.

M. Trouble Shooting

No power	<ul style="list-style-type: none"> • Check battery is it charged with enough energy. • Check whether the device is in power OFF mode.
No sound	<ul style="list-style-type: none"> • Check whether volume level is in lower position on your speaker and mobile phone or PC/Mac. • Make sure that your Bluetooth device is within the effective operation range. • Check whether the Bluetooth device is paired. • Check whether the Bluetooth device show connected. • Check if you have selected the correct

	audio source.
No response from speaker	• Restart the speaker by power Off and On.

N. Specification		
Dimension	75 mm (L) x 75 mm (W) x 46.5 mm (H) (Not included Vacuum Cupule)	
Weight	86.5g (Not included Vacuum Cupule) 102.5g (with Vacuum Cupule)	
Bluetooth	Specification	V2.1 + EDR
	Supported Profile	A2DP, AVRCP, HSP
	Connection Distance	In 10 meters (open area)
Built-In Battery	Lithium 3.7V, 300mAh	
	Playing Time: about 2 Hours (at 75% of volume setting)	
Power Source	Micro USB Port	
	PC's USB port Power or DC 5V, 500mA	
Audio	Output Power	2W (RMS) at 4 Ohm
	Frequency Responses	100Hz to 20,000Hz
	Operating Temperature	

O. Disclaimer

Updates to Firmware and/or hardware components are made regularly. Therefore some of the instruction, specifications and pictures in this documentation may differ slightly from your particular situation. All items described in this guide for illustration purposes only and may not apply to particular situation. No legal right or entitlements may be obtained from the description made in this manual.

P. Recycling



This symbol indicates that the relevant electrical product or battery should not be disposed of as general household waste in Europe. To ensure the correct waste treatment of the product and battery, please dispose them in accordance to any applicable local laws of requirement for disposal of electrical equipment or batteries. In so doing, you will help to conserve natural resources and improve standards of environmental protection in treatment and disposal of electrical waste (Waste Electrical and Electronic Equipment Directive).

FCC Warning Statement

Changes or modifications not expressly approved by the party responsible for compliance could void the user's authority to operate the equipment.

This equipment has been tested and found to comply with the limits for a Class B digital device, pursuant to Part 15 of the FCC Rules. These limits are designed to provide reasonable protection against harmful interference in a residential installation. This equipment generates uses and can radiate radio frequency energy and, if not installed and used in accordance with the instructions, may cause harmful interference to radio communications. However, there is no guarantee that interference will not occur in a particular installation. If this equipment does cause harmful interference to radio or television reception, which can be determined by turning the equipment off and on, the user is encouraged to try to correct the interference by one or more of the following measures: --Reorient or relocate the receiving antenna.

--Increase the separation between the equipment and receiver. --Connect the equipment into an outlet on a circuit different from that to which the receiver is connected. --Consult the dealer or an experienced radio/TV technician for help.