

2

IEEE 802.11a/g (D377)

Accessories

Check the accessories and their quantities against the following list:

No	Description	Quantity
1	IEEE 802.11a/g Interface Board	1
2	Antenna Cables	2
3	Antenna Clamps	8

Installation

 CAUTION

- Turn off the main power switch and disconnect the power supply cord.

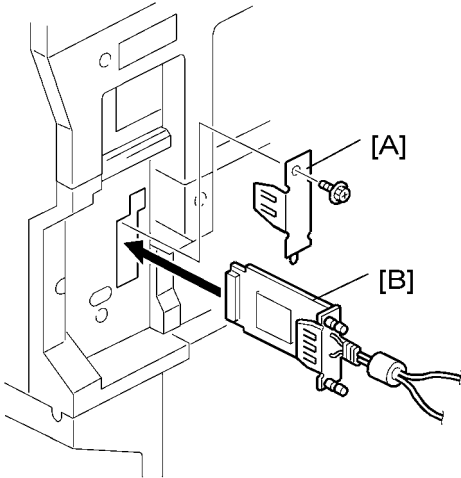

d017i507

1. Remove the plastic application cover (🔩 x1).
2. Remove the cover [A] of the board slot (🔩 x1).
3. Insert the interface card [B] as shown above.

⬇ **Note**

- Use a screwdriver to tighten the knob-screws. Do not tighten manually, because this can disconnect the board.
4. Look at the markings on the antenna bracket.
 - **ANT1**. Antenna 1 transmits and receives. It must be installed on the front left corner of the main machine. (The core on the Antenna 1 cable is black.)
 - **ANT2**. Antenna 2 only receives. It is installed on the rear right corner of the machine.

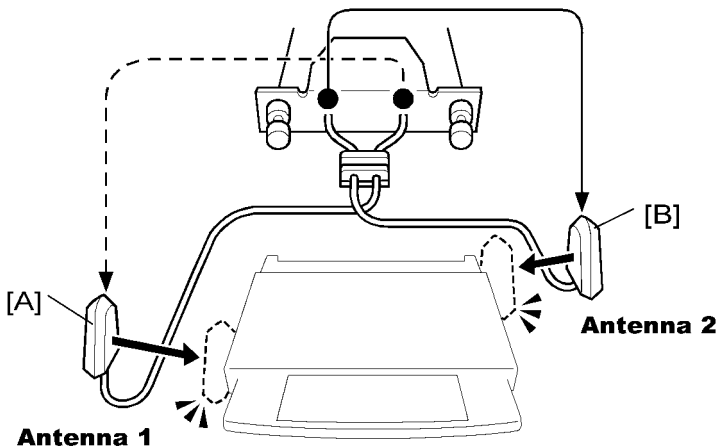

d017i508

★ Important

- To assure reliable data sending and receiving, Antenna 1 must be installed on the front left corner of the machine.

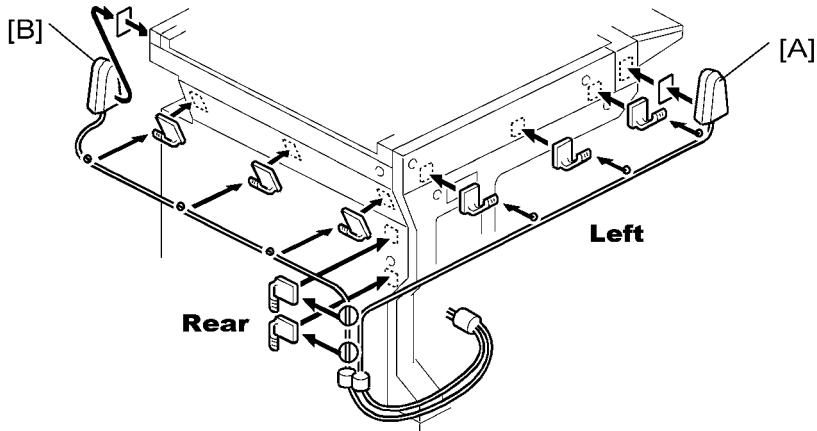

d017:509

5. Remove the seals from the cable clamps and attach them to the left side of the machine as shown above.
6. Attach Antenna 1 [A] to the left front corner of the machine. (The core on the Antenna 1 cable is black.)
7. Set the cable of Antenna 1 in the clamps and close them.
8. Remove the seals from the cable clamps and attach them to the rear of the machine as shown above.
9. Attach Antenna 2 [B] to the right rear corner of the machine.
10. Set the cable of Antenna 2 in the clamps and close them.