

RIDGID®

TS2400

OPERATORS MANUAL

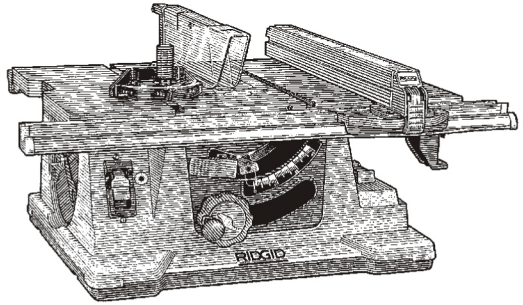

HEAVY DUTY 10" PORTABLE TABLE SAW with STAND

Call Us 1st

For any questions about:

- Operation
- Warranty (See back cover)
- Technical Assistance
- Repair Parts

*Please have your Model Number and
Serial Number on hand when calling.*

1-866-539-1710

RIDGIDParts.com

POWER TOOL PARTS
& ACCESSORIES



WARNING:

**Read and follow all Safety
Rules before first use of this
product.**

Table of Contents

Section	Page	Section	Page
Table of Contents	2	Workbench Mounting Using "C" Clamps ..	34
Safety Instructions For Table Saw	3	Supporting Table Saw with Sawhorses	34
Safety Signal Words	3	Safety Instructions for Basic Saw	
Before Using The Saw	3	Operations	35
When Installing Or Moving The Saw	4	Before Each Use	35
Before Each Use	4	To Reduce the Risk of Injury From Jams, Slips Or Thrown Pieces (Kickbacks Or Throwbacks)	35
To Reduce the Risk of Injury From Jams, Slips Or Thrown Pieces (Kickbacks Or Throwbacks)	5	Plan Ahead To Protect Your Eyes, Hands, Face and Ears	36
Plan Ahead To Protect Your Eyes, Hands, Face and Ears	6	Whenever Sawblade Is Spinning	37
Whenever Sawblade Is Spinning	7	Work Feed Devices	38
Additional Safety Instructions For: Rip Cuts..	8	Attaching Wood Face Board	39
Additional Safety Instructions For: Crosscuts	9	Push Block	39
Glossary of Terms for Woodworking	9	Work Feed Devices	40
Motor Specifications and Electrical		Auxiliary Fence	40
Requirements	11	Fence Facing	41
Power Supply and Motor Specifications ..	11	Basic Saw Operations	42
General Electrical Connections	11	Using the Miter Gauge	42
Motor Specifications and Electrical		Additional Safety Instructions for Crosscutting	42
Requirements	12	Crosscutting	42
Thermal Overload Protector	13	Repetitive Crosscutting	43
Wire Sizes	13	Miter Crosscutting	44
Unpacking and Checking Contents	14	Bevel Crosscutting	44
Unpacking	14	Compound Crosscutting	44
List of Loose Parts	14	Using the Rip Fence	45
Getting to Know Your Table Saw	15	Additional Safety Instructions for Rip Cuts	45
Alignment	20	Ripping	46
Tools Needed	20	Bevel Ripping Narrow Work	47
Remove Foam Motor Support	20	Using Featherboards for Thru Sawing	48
Checking Table Insert	20	Using Featherboards for Non-Thru Sawing.....	49
Checking Heeling Adjustment or Parallelism of Sawblade to Miter Gauge Groove	21	Resawing	50
Checking Blade Tilt, or Squareness of Blade to Table	23	Using Carbide Tipped Blades	50
To Check For Squareness, 90° Position ..	23	Dadoing	51
Adjusting Rip Fence Guide Bars	25	Rabbeting	52
Aligning Sliding Table Extension	26	Ploughing and Molding	52
Rip Fence Alignment Adjustment	26	Molding	53
Rip Fence Lock Lever Adjustment	27	Maintaining Your Table Saw	54
Adjusting Rip Indicator	27	Maintenance	54
Checking Sliding Table Extension	28	Adjusting Nylon Set Screw	54
Installing Blade Guard	28	Replacing Carbon Brushes	55
Aligning Blade Guard	29	Lubrication	55
Removing and Installing Sawblade	30	RIDGID Recommends the Following	
Miter Gauge Alignment	31	Accessories	55
Adjusting Bevel Lock	32	Troubleshooting	56
Mounting Your Saw	33	General	56
Mounting Table Saw to Workbench or Legset	33	Motor	57
Workbench Mounting Using Hardware	33	Repair Parts	58
Table Saw Mounting Procedures	33	Notes	65
Mounting Table Saw to RIDGID Universal Power Tool Legset #AC9910	34		

Safety Instructions For Table Saw

Safety is a combination of common sense, staying alert and knowing how your table saw works. Read this manual to understand this table saw.

Safety Signal Words

DANGER: means if the safety information is not followed someone **will** be seriously injured or killed.

WARNING: means if the safety information is not followed someone

could be seriously injured or killed.

CAUTION: means if the safety information is not followed someone **may** be injured.

Before Using The Saw

WARNING: Some dust created by power sanding, sawing, grinding, drilling, and other construction activities contains chemicals known (to the State of California) to cause cancer, birth defects or other reproductive harm. Some examples of these chemicals are:

Lead from lead-based paints

- **Crystalline silica from bricks and cement and other masonry products, and**
- **Arsenic and chromium from chemically-treated lumber.**

Your risk from these exposures varies, depending on how often you do this type of work. To reduce your exposure to these chemicals: work in a well ventilated area, and work with approved safety equipment, such as those dust masks that are specially designed to filter out microscopic particles.

WARNING: To reduce the risk of mistakes that could cause serious, permanent injury, do not plug the table saw in until the following steps have been satisfactorily completed.

- Completely align and align saw (See "Alignment" section).
- Learn the use and function of the ON-OFF switch, blade guard, spreader, anti-kickback device, miter gauge, rip fence, table insert, blade elevation and blade bevel lock controls (See "Getting to Know Your Table Saw" section).
- Review and understand all safety instructions and operating procedures in this manual.
- Review the maintenance methods for this saw (See "Maintaining Your Table Saw" section)).

Safety Instructions For Table Saw (continued)

- Find and read all the warning labels found on the saw (shown below).

⚠ WARNING	
<ol style="list-style-type: none"> 1. Read the manual before using saw. 2. Wear safety goggles that meet ANSI Z87.1 or in Canada CSA Z94-3-M88 standards. 3. Do not reach around or over saw blade. 4. Keep blade guard down and in place for through cuts. 5. Do not do freehand cuts. 6. Keep hands out of path of sawblade. 7. When ripping, use push block and auxiliary fence when fence is set between 1/2 and 2 inches from blade. Do not make rip cuts narrower than 1/2 inch. 	<ol style="list-style-type: none"> 8. When ripping, use push stick when fence is set 2 inches or more from blade. 9. Know how to reduce the risk of kickback. See instructions for ripping. 10. Turn power off and wait for blade to stop before adjusting or servicing. 11. Plug power cord into a properly grounded outlet protected by a 15 amp circuit breaker or time delay fuse. In Canada use time delay fuse marked "D". 12. Do not expose to rain or use in damp locations.

⚠ WARNING	⚠ ADVERTENCIA	⚠ AVERTISSEMENT
Debris on fence rail can misalign the fence. Workpiece could bind or suddenly kick back. You could be hit or cut. Clean debris off fence rail before positioning fence.	Los residuos que están en el riel del topo-guía pueden desalinear al topo-guía. La pieza de trabajo podría atascarse o experimentar retroceso repentino. Usted podría resultar golpeado o cortado. Elimine los residuos del riel del topo-guía antes de posicionar el topo-guía.	Des rails de guide sales peuvent causer le mauvais alignement de guide. Colètement ou éjection soudaine de la pièce vers l'arrière sont possibles avec risque de vous frapper ou de vous couper. Nettoyer les rails du guide avant de le positionner.

⚠ WARNING	⚠ ADVERTENCIA	⚠ AVERTISSEMENT
When mounting an auxiliary fence face, position mounting hardware beyond arrows at right and left. Keep fasteners away from blade.	Cuando monte una cara de topo-guía auxiliar, posicione los herrajes de montaje más allá de las flechas que están a la derecha y a la izquierda. Mantenga las piezas de sujeción alejadas de la hoja.	Lors du montage d'une plaque de guide auxiliaire, placer les éléments de fixation au-delà des flèches à droite et à gauche et les tenir éloignés de la lame.



⚠ WARNING
<ul style="list-style-type: none"> • Raised guard can drop on spinning blade and break. Severe injury can result. • When used, guard must be down in place. • Tighten spreader fasteners before use.

When Installing Or Moving The Saw

Reduce the Risk of Dangerous Environment.

- Use the saw in a dry, indoor place protected from rain.
- Keep work area well lighted.
- Use recommended accessories. Consult the owner's manual for recommended accessories. The use of improper accessories may cause risk of injury to persons.

To reduce the risk of injury from unexpected saw movement.

- Bolt or clamp the saw to firm level surface where there is plenty of room to handle and properly support the workpiece (See "Assembly-Mounting Your Saw" section).

- Support the saw so the table is level and the saw does not rock.
- Put the saw where neither operator nor bystanders must stand in line with the sawblade.
- To reduce the risk of injury from electrical shock, make sure your fingers do not touch the plug's metal prongs when plugging in or unplugging the saw.
- **Never Stand On Tool.** Serious injury could occur if the tool tips or you accidentally hit the cutting tool. Do not store anything above or near the tool where anyone might stand on the tool to reach them.

Before Each Use

Inspect your saw.

- To reduce the risk of injury from accidental starting, turn the switch off, unplug the saw, and remove the switch key before raising or removing the guard, changing the cutting tool, changing the setup, or adjust-

- ing anything. Make sure switch is in OFF position before plugging in.
- Check for alignment of moving parts, binding of moving parts, breakage of parts, saw stability, and any other conditions that may affect the way the saw works.

- If any part is missing, bent or broken in any way, or any electrical part does not work properly, turn the saw off and unplug the saw.
- Replace damaged or missing parts before using the saw again.
- Use the sawblade guard, spreader and anti-kickback pawls for any thru-sawing (whenever the blade comes through the top of the workpiece). Make sure the anti-kickback pawls work properly. Make sure the spreader is in line with sawblade (See “Assembly-Aligning Blade Guard” section).
- Remove adjusting keys and wrenches. Form a habit of checking for and removing keys and adjusting wrenches from table top before turning saw on.
- Make sure all clamps and locks are tight and no parts have excessive play.

To Reduce the Risk of Injury From Jams, Slips Or Thrown Pieces (Kickbacks Or Throwbacks)

Inspect Your Blade.

- Choose the right blade or cutting accessory for the material and the type of cutting you plan to do.
- Use The Right Tool. Don't force tool or attachment to do a job it was not designed for.
- Never use grinding wheels, abrasive cutoff wheels, friction wheels (metal cutting blades) wire wheels or buffing wheels. They can fly apart explosively.
- Cut only wood, wood like or plastic materials. Do not cut metal.
- Choose and inspect your cutting tool carefully:
 - To reduce the risk of cutting tool failure and thrown shrapnel (broken pieces of blade), use only 10" or smaller blades or other cutting tools marked for speeds of 5000 rpm or higher.
 - Always use unbroken, balanced blades designed to fit this saw's 5/8 inch arbor.
 - When thru-sawing (making cuts where the blade comes through the workpiece top), always use a 10 inch diameter blade. This keeps the spreader closest to the blade.
- Do not over tighten arbor nut. Use arbor wrenches to “snug” it securely.
- Use only sharp blades with properly set teeth. Consult a professional blade sharpener when in doubt.
- Keep blades clean of gum and resin.
- Never use the saw without the proper blade insert.

Inspect your work area

- Keep work area clean.
- Cluttered areas and benches invite accidents. Floor must not be slippery from wax or sawdust.
- To reduce the risk of burns or other fire damage, never use the saw near flammable liquids, vapors or gases.
- To reduce the risk of injury, don't do layout, assembly, or setup work on the table while blade is spinning. It could cut or throw anything hitting the blade.

Safety Instructions For Table Saws (continued)

Plan your work

- Use the right tool. Don't force tool or attachment to do a job it was not designed for.

Inspect your workpiece.

- Make sure there are no nails or foreign objects in the part of the workpiece to be cut.
- When cutting irregularly shaped workpieces, plan your work so it will not slip and pinch the blade:
 - A piece of molding for example, must lie flat or be held by a fixture or jig that will not let it twist, rock or slip while being cut. Use jigs or fixtures where needed to prevent workpiece from shifting.
- Use a different, better suited type of tool for work that can't be made stable.

Plan your cut

- To reduce the risk of kickbacks and throwbacks - when a part or all of the workpiece binds on the blade and is thrown violently back toward the front of the saw:
- Never cut **Freehand**. Always use either a rip fence, miter gauge or fixture to position and guide the work, so it won't twist or bind on the blade

and kick back.

- Make sure there's no debris between the workpiece and its supports.
- Use extra caution with large, very small or awkward workpieces.
- Use extra supports (tables, saw horses, blocks, etc.) for any workpieces large enough to tip when not held down to the table top. Never use another person as a substitute for a table extension, or as additional support for a workpiece that is longer or wider than the basic saw table, or to help feed, support or pull the workpiece.
- Never confine the piece being cut off, that is, the piece not against the rip fence, miter gauge or fixture. Never hold it, clamp it, touch it, or use length stops against it. It must be free to move. If confined, it could get wedged against the blade and cause a kickback or throwback.
- Never cut more than one workpiece at a time.
- Never turn your table saw "ON" before clearing everything except the workpiece and related support devices off the table.

Plan Ahead To Protect Your Eyes, Hands, Face and Ears

Dress for safety

- Do not wear loose clothing, gloves, neckties or jewelry (rings, wrist watches). They can get caught and draw you into moving parts.
- Wear nonslip footwear.
- Tie back long hair.
- Roll long sleeves above the elbow.
- Noise levels vary widely. To reduce the risk of possible hearing damage, wear ear plugs or muffs when using

table saw for hours at a time.

- Any power saw can throw foreign objects into the eyes. This can result in permanent eye damage. Always wear safety goggles, not glasses complying with ANSI Z87.1 (or in Canada CSA Z94.3-99) shown on package. Everyday eyeglasses have only impact resistant lenses. They are not safety glasses. Safety goggles are available at many local

retail stores. Glasses or goggles not in compliance with ANSI or CSA could seriously hurt you when they break.



- For dusty operations, wear a dust mask along with safety goggles.

Plan the way you will push the workpiece through.

- **Never pull the workpiece through.** Start and finish the cut from the front of the table saw.
- **Never put your fingers or hands in the path** of the sawblade or other cutting tool.
- **Never reach in back** of the cutting tool with either hand to hold down workpiece, support the workpiece, remove wood scraps, or for any other reason.

- Reduce the risk of hand positions where a sudden slip could cause fingers or hand to move into a sawblade or other cutting tool.
- Don't overreach. Always keep good footing and balance.
- Push the workpiece against the rotation of the blade, never feed material into the cutting tool from the rear of the saw.
- Always push the workpiece all the way past the sawblade.
- As much as possible, keep your face and body to one side of the sawblade, out of line with a possible kickback or throwback.
- Set the cutting tool as low as possible for the cut you're planning.

Reduce the Risk of Accidental Starting

- Make sure switch is "OFF" before plugging saw into a power outlet.

Whenever Sawblade Is Spinning

WARNING: Don't allow familiarity (gained from frequent use of your table saw) to cause a careless mistake. Always remember that a careless fraction of a second is enough to cause a severe injury.

- Before actually cutting with the saw, watch it while it runs for a short while. If it makes an unfamiliar noise or vibrates a lot, stop immediately. Turn the saw off. Unplug the saw. Do not restart until finding and correcting the problem.
- Make sure the top of the arbor or cutting tool turns toward the front of the saw.

Keep Children Away.

- Keep all visitors a safe distance from the table saw.

- Make sure bystanders are clear of the table saw and workpiece.

Don't Force Tool.

- Let the blade reach full speed before cutting.
- It will do the job better and safer at its designed rate.
- Feed the workpiece into the saw only fast enough to let the blade cut without bogging down or binding.

Before freeing jammed material.

- Turn switch "OFF".
- Wait for all moving parts to stop.
- Unplug the saw.
- Check blade, spreader and fence for proper alignment before starting again.

Safety Instructions For Table Saws (continued)

To reduce the risk of throwback of cut off pieces.

- Use the guard assembly.

To remove loose pieces beneath or trapped inside the guard.

- Turn saw "OFF".
- Remove switch key.
- Wait for blade to stop before lifting the guard.

Before Leaving The Saw.

- Turn the saw off.
- Wait for blade to stop spinning.
- Unplug the saw.
- Make workshop child-proof. Lock the shop. Disconnect master switches. Remove the yellow switch key. Store it away from children and others not qualified to use the tool.

Additional Safety Instructions For:

Rip Type Cuts.

- Never use the miter gauge when ripping. Store the miter gauge in the area provided in the base.
- Use a push stick whenever the fence is 2 inches or more from the blade.
- When thru-sawing, use an auxiliary fence and push block whenever the fence must be between 1/2 and 2 inches from the blade.
- Never thru-saw rip cuts narrower than 1/2 inch. (See "Basic Saw Operations-Ripping and Bevel Ripping" sections.)
- Never rip anything shorter than 10" long.
- When using a push stick or push block, the trailing end of the board must be square. A push stick or block against an uneven end could slip off or push the work away from the fence.
- A Featherboard can help guide the workpiece. (see "Basic Saw Operation-Using Featherboards for Thru-Sawing." section)
- Always use featherboards for any non thru rip type cuts. (See "Basic Saw Operations - Using Featherboards for Non-Thru Sawing" section).

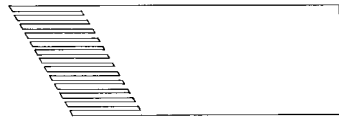

Featherboard
See "Work Feed Devices" section for Material and Dimensions

Before Starting.

- To reduce the risk of kickbacks and slips into the blade, make sure the rip fence is parallel to the sawblade.
- Before thru-sawing, check the anti-kickback pawls. The pawls must stop a kickback once it has started. Replace or sharpen anti-kickback pawls when points become dull. (See "Maintaining Your Table Saw - Anti-Kickback Pawls" section.)
- Plastic and composition (like hard-board) materials may be cut on your saw. However, since these are usually quite hard and slippery, the anti-kickback pawls may not stop a kickback. Therefore, be especially careful in your setup and cutting procedures.

While Thru-sawing.

- To reduce the risk of kickbacks and slips into the blade, always push forward on the section of the workpiece between the sawblade and the rip fence. Never push forward on the piece being cut off or directly in line with the blade.

Additional Safety Instructions For:

Crosscut Type Cuts.

- Never use the rip fence when cross-cutting.
- An auxiliary wood facing attached to the miter gauge can help prevent workpiece twisting and throwbacks. Attach it to the slots provided. Make the facing long enough and big enough to support your work. Make sure, however, it will not interfere with the sawblade guard.

Before Starting

- Use jigs or fixtures to help hold any piece too small to extend across the full length of the miter gauge face during the cut. This lets you properly hold the miter gauge and workpiece and helps keep your hands away from the blade.

While Cutting

- To reduce the risk of blade contact, always hold the miter gauge as shown in “Basic Saw Operations - Using The Miter Gauge”.

Glossary of Terms for Woodworking ---

Anti-Kickback Pawls

Device which, when properly maintained, is designed to stop the workpiece from being thrown towards the front of the saw at the operator during ripping operation.

Arbor

The shaft on which a cutting tool is mounted.

Bevel Cut

An angle cutting operation made through the face of the workpiece.

Compound Cut

A simultaneous bevel and miter crosscutting operation.

Crosscut

A cutting operation made across the width of the workpiece.

Dado

A non thru cut which produces a square sided notch or trough in the workpiece.

Featherboard

A device which can help guide workpieces during rip type operation.

Freehand

Performing a cut without the use of fence (guide), miter gauge, fixture, hold down or other proper device to prevent the workpiece from twisting during the cutting operation. Twisting of the workpiece can cause it to be thrown.

Gum

A sticky, sap based residue from wood products.

Heel

Misalignment of the sawblade such that the blade is not parallel to the miter gauge groove.

Kerf

The amount of material removed by the blade in a through cut or the slot produced by the blade in a nonthrough or partial cut.

Kickback

An uncontrolled grabbing and throwing of the workpiece back toward the front of the saw.

Leading End

The end of the workpiece which, during a rip type operation, is pushed into the cutting tool first.

Miter Cut

An angle cutting operation made across the width of the workpiece.

Molding

A non through cut which produces a special shape in the workpiece used for joining or decoration.

Ploughing

Grooving with the grain the length of the workpiece, using the fence. (A type of non-through cut.)

Glossary of Terms for Woodworking (continued) ---

Push Stick

A device used to feed the workpiece through the saw during narrow ripping type operations which helps keep the operator's hands well away from the blade.

Push Block

A device used for ripping type operations too narrow to allow use of a push stick.

Rabbet

A notch in the edge of a workpiece. (A type of non-through cut)

Resin

A sticky, sap based substance that has hardened.

Revolutions Per Minute (RPM)

The number of turns completed by a spinning object in one minute.

Rip Cut

A cutting operation along the length of the workpiece.

Sawblade Path

The area of the workpiece or table top directly in line with either the travel of the blade or the part of the workpiece which will be, or has been, cut by the blade.

Set

The distance that the tip of the sawblade tooth is bent (or set) outward from the face of the blade.

Throw-Back

Throwing of pieces in a manner similar to a kickback.

Thru-Sawing

Any cutting operation where the blade extends completely through the thickness of the workpiece.

Trailing End

The workpiece end last cut by the blade in a ripping operation.

Workpiece

The item on which the cutting operation is being performed. The surfaces of a workpiece are commonly referred to as faces, ends, and edges.

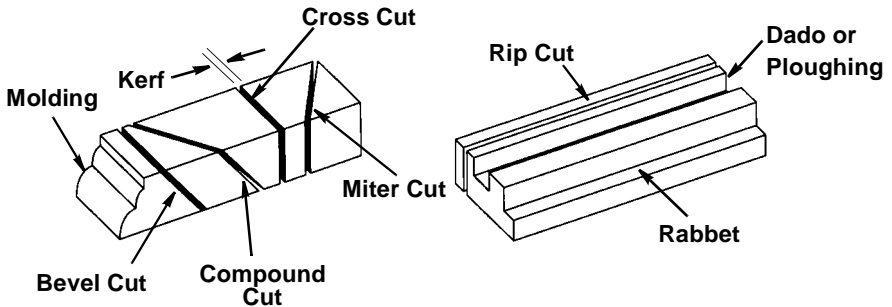

Motor Specifications and Electrical Requirements

Power Supply and Motor Specifications

WARNING: To reduce the risk of electrical hazards, fire hazards or damage to the tool, use proper circuit protection. Your tool is wired at the factory for operation using the voltage shown. Connect tool to a power line with the appropriate voltage and a 15-amp branch circuit. Use a 15-amp time delay type fuse or circuit breaker. To reduce the risk of shock or fire, if power cord is worn or cut, or damaged in any way, have it replaced immediately.

The A-C motor used on this tool is a universal non-reversible type, having the following specifications.

Voltage	120
Amperes	15
Hertz (Cycles)	60
Phase	Single
RPM	4000
Rotation of Shaft	Counterclockwise (Blade End)

General Electrical Connections

DANGER: To reduce the risk of electrocution:

1. Use only identical replacement parts when servicing. Servicing should be performed by a qualified service technician.
2. Do not use in rain or where floor is wet.
This tool is intended for indoor residential use only.

WARNING: Do not permit fingers to touch the terminals of plug when installing or removing the plug to or from the outlet.

110-120 Volt, 60 Hz. Tool Information

The plug supplied on your tool may not fit into the outlet you are planning to use. Your local electrical code may require slightly different power cord plug connections. If these differences exist refer to and make the proper adjustments per your local code before your tool is plugged in and turned on.

In the event of a malfunction or breakdown, grounding provides a path of least resistance for electric current to reduce

the risk of electric shock. This tool is equipped with an electric cord having an equipment-grounding conductor and a grounding plug, as shown. The plug must be plugged into a matching outlet that is properly installed and grounded in accordance with all local codes and ordinances.

Do not modify the plug provided. If it will not fit the outlet, have the proper outlet installed by a qualified electrician.

Motor Specifications and Electrical Requirements (continued)

A temporary adapter may be used to connect this plug to a 2-prong outlet as shown if a properly grounded three prong outlet is not available. This temporary adapter should be used only until a properly grounded three prong outlet can be installed by a qualified electrician. The green colored rigid ear, lug or the like, extending from the adapter must be connected to a permanent ground such as a properly grounded outlet box.

Improper connection of the equipment-grounding conductor can result in a risk of electric shock. The conductor with insulation having an outer surface that is green with or without yellow stripes is the equipment-grounding conductor. If repair or replacement of the electric cord or plug is necessary, do not connect the equipment-grounding conductor to a live terminal.

If the grounding instructions are not completely understood, or if you are in doubt as to whether the tool is properly grounded check with a qualified electrician or service personnel.

WARNING: If not properly grounded, this tool can cause an electrical shock, particularly when used in damp locations, in proximity to plumbing, or out of doors. If an electrical shock occurs there is the potential of a secondary hazard, such as your hands contacting the sawblade.

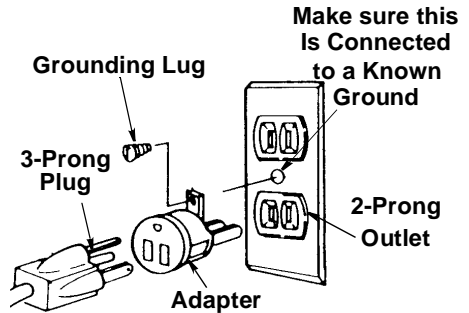
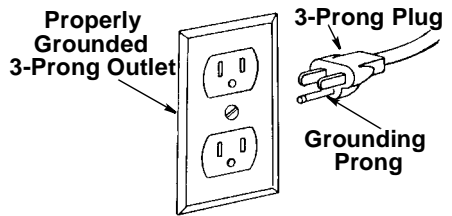

NOTE: The adapter illustrated is for use only if you already have a properly grounded 2-prong outlet.

NOTE: In Canada the use of a temporary adapter is not permitted by the Canadian Electrical Code.

CAUTION: To reduce the risk of motor damage, this motor should be blown out or vacuumed frequently to prevent sawdust buildup which will interfere with normal motor ventilation.

1. Frequent "blowing" of fuses or tripping of circuit breakers may result if:
 - a. Motor is overloaded - Overloading can occur if you feed too rapidly or if saw blade is dull or misaligned.
 - b. Motor circuit is fused differently from recommendations - Always follow instructions for the proper fuse/breaker. Do not use a fuse/breaker of greater capacity without consulting a qualified electrician.
 - c. Low voltage - Although the motor is designed for operation on the voltage

and frequency specified on motor nameplate, normal loads will be handled safely on voltage not more than 10% above or below the nameplate voltage. Heavy loads, however, require that voltage at motor terminals equals the voltage specified on nameplate.

2. Most motor troubles may be traced to loose or incorrect connections, overloading, reduced input voltage (such as small size wire in the supply circuit or extension cord) or to overly long supply circuit wire or extension cord. Always check the connections, the load and the supply circuit whenever motor fails to perform satisfactorily. Check wire sizes and length with the Wire Size Chart below.

Thermal Overload Protector

This saw is equipped with a thermal overload device which will automatically "trip" and cause the saw to shut down if the motor is overheating due to continuous heavy cutting or stalling.

The overload device can only be reset manually by the user after the motor has been allowed to adequately cool. Allow 15-30 minutes.

Should the overload protector "trip":

1. Turn switch off and remove key.
2. Remove workpiece.

3. Wait 15-30 minutes.
4. Push in on the reset button.
5. If motor has cooled, button will remain in.

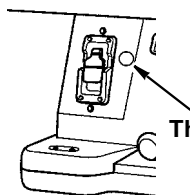

Thermal Overload Device

Wire Sizes

NOTE: Make sure the proper extension cord is used and is in good condition.

The use of any extension cord will cause some loss of power. To keep this to a minimum and to prevent overheating and motor burn-out, use the table shown to determine the minimum wire size (A.W.G.) extension cord.

Use only 3-wire extension cords which have 3-prong grounding type plugs and 3-prong receptacles which accept the tool's plug.

Extension Cord Length	Gauge (A.W.G.)
0-25 Ft.	14
26-50 Ft.	12

Unpacking and Checking Contents

Unpacking

Separate saw and all parts from packing materials and check each one with the illustration and the "List of Loose Parts" to make certain all items are accounted for, before discarding any packing material. Call 1-866-539-1710 or E-mail us at info@ridgidwoodworking.com if any parts are damaged or missing.

WARNING: If any parts are missing, do not attempt to use the table saw, plug in the power cord or turn the switch on until the missing parts are obtained and are installed correctly.

WARNING: The saw is heavy. To reduce the risk of back injury, hold the saw close to your body. Bend your knees so you can lift with your legs, not your back. Use hand holds provided.

WARNING: For your own safety, never connect plug to power source outlet until all assembly steps are complete, and you have read and understand the safety and operating instructions.

List of Loose Parts

Item	Part Name	Qty.
A	Table Saw Assembly	1
B	Miter Gauge.....	1
C	Blade Guard and Spreader.....	1
D	Rip Fence.....	1
E	Arbor Wrenches	2
Item	Part Name	Qty.
F	Safety Key.....	1
G	Blade Storage Washers.....	2
H	Blade Storage Wingnut.....	1
J	Operators Manual.....	1

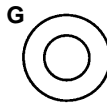
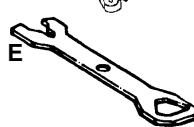
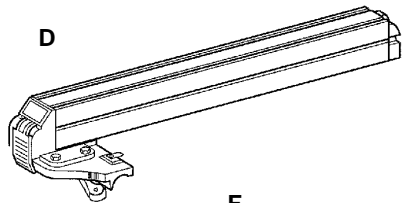
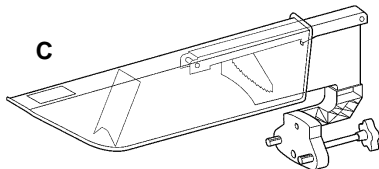
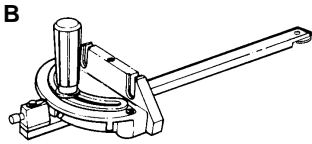
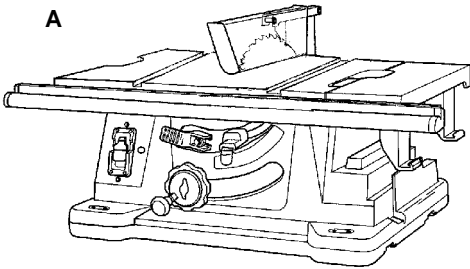

Getting to Know Your Table Saw

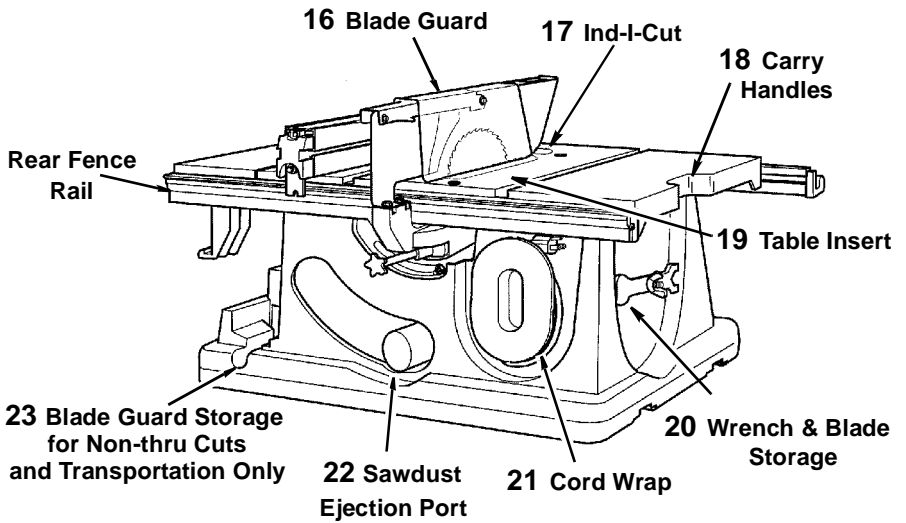
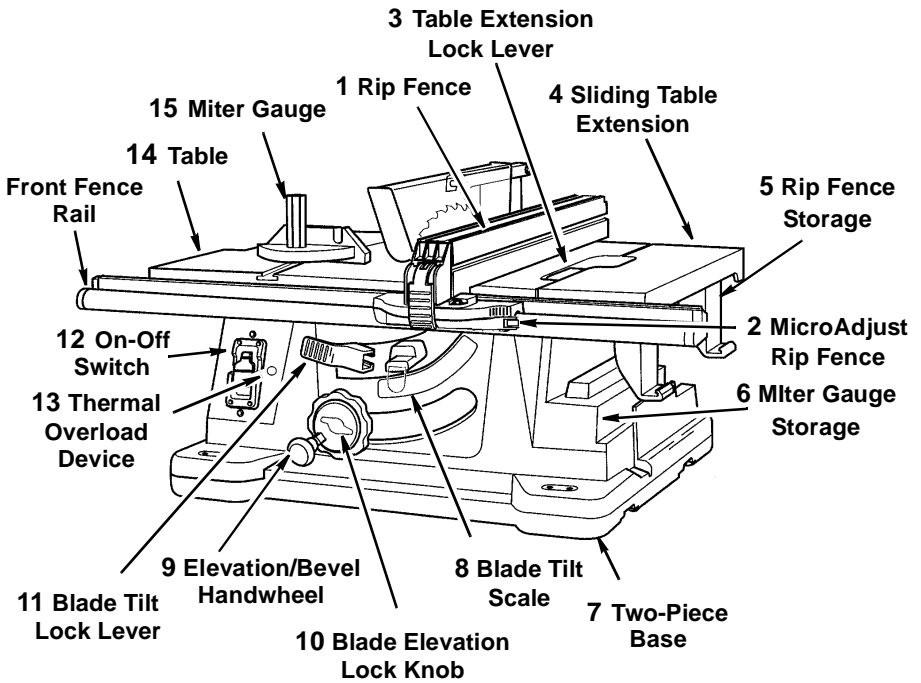

Getting to Know Your Table Saw

1. **Rip Fence...**is locked in place by pushing the lock lever down until the lever rests on the stop. To move the fence, lift the lock lever and grasp the fence with one hand at the front. "T" slots are provided in the rip fence for attaching a wood facing when using the dado head, or molding head.
2. **Micro-Adjust Rip Fence...**allows the operator to accurately adjust the rip fence using only one hand. To move the fence push in on the micro-adjust knob and rotate.
3. **Table Extension Lock Lever...**Locks the sliding table extension.
4. **Sliding Table Extension...**provides additional working surface to support large workpieces and increase rip capability.
5. **Rip Fence Storage...**holds the fence when not being used.
6. **Miter Gauge Storage...**holds the miter gauge when not being used.
7. **Two-Piece Base...**supports table. For additional stability, holes are provided in base to bolt the saw to a workbench or stand or sawhorses.
8. **Blade Bevel Scale...**shows the degree the blade is beveled.
9. **Elevation/Bevel Handwheel**
 - a. Elevates or lowers the blade.
Turn the knob clockwise to elevate, counterclockwise to lower.
 - b. Use the knob to quickly tilt the blade from 0° to 45°. Rotate the outer hub for finer adjustments. When the blade is tilted to the left as far as it will go, it should be at 45° to the table and the bevel

pointer should point to 45°.

NOTE: There are limit stops inside the saw which prevent the blade from tilting beyond 45° to the left and 0°. (See "Adjustments and Alignments" section "Blade Bevel, or Squareness of Blade to Table").

10. **Blade Elevation Lock Knob...**locks the blade at the desired height.
11. **Blade Bevel Lock Lever...**locks the blade in the desired bevel position. Lift the lever to the right to unlock push to the left to lock.
12. **On-Off Switch**

CAUTION: Before turning switch "ON", make sure the blade guard is correctly installed and operating properly.

The On-Off Switch has a locking feature. This feature is intended to help prevent unauthorized and possible hazardous use by children and others.

- a. To turn saw ON, insert key, stand to either side of the blade, never in line with it, place finger under switch lever and pull end of lever out. After turning switch ON, always allow the blade to come up to full speed before cutting. Do not cycle the motor switch on and off rapidly, as this may cause the sawblade to loosen. In the event this should ever occur, allow the sawblade to come to a complete stop and retighten the arbor nut normally, not excessively. Never leave the saw while the power is ON.

- b. To turn saw OFF, PUSH lever in. Never leave the saw until the cutting tool has come to a complete stop.
- c. To lock switch in OFF position, hold switch IN with one hand, REMOVE key with other hand.

WARNING: For your own safety, lower blade or other cutting tool below table surface. (If blade is tilted, return it to vertical, 90° position.) Always lock the switch "OFF". When saw is not in use, remove key and keep it in a safe place. Also, in the event of a power failure (all of your lights go out) turn switch off, lock it and remove the key. This will prevent the saw from starting up again when the power comes back on.

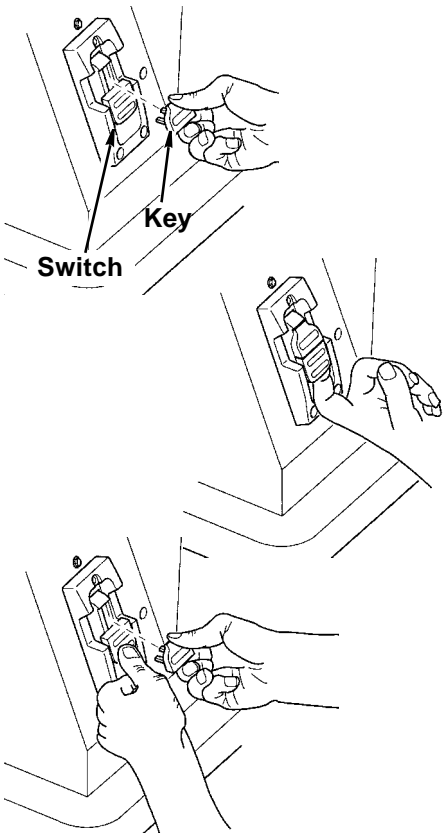

13. Thermal Overload Device...opens the power line circuit when the motor temperature exceeds a safe level, when the motor is overloaded or when a lower voltage condition exists. It can be reset by pressing the reset button after the motor returns to normal temperate.

14. Table...provides working surface to support workpieces.

15. Miter Gauge...head is locked in position for cross cutting or mitering by tightening the lock knob. Always securely lock it when in use.

- a. There are adjustable screw stops for the stop pin 0° and 45° right and left positions for conveniently setting the miter gauge to cut miters at these standard angles.

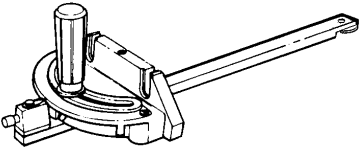

16. Blade Guard

Use the sawblade guard, spreader and anti-kickback pawls for any thru-sawing (whenever the blade comes through the top of the workpiece). Make sure the anti-kickback pawls work properly. Make sure the spreader is in line with sawblade. (See "Aligning Blade Guard" section)

To remove the guard for special operations, loosen the blade guard locking knob. Do not disturb the setting of the spreader bracket.

When replacing the guard, position the two (2) locator pins on the blade guard into the matching holes in the cradle. Securely tighten the blade guard locking knob.

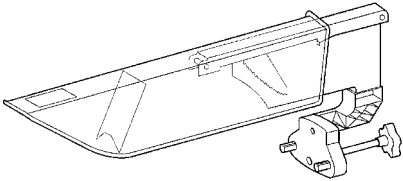

Getting to Know Your Table Saw (continued)

17. Ind-I-Cut

The plastic disk embedded in the table in front of the sawblade, is provided for marking the location of the "sawcut" (kerf) on the workpiece.

Check disk location: If it is above table surface, place a piece of hardwood on top of it and tap it down with a hammer.

18. Carry Handles...grasp the table here when picking up the saw.

19. Table Insert

Is removable for removing or installing blade or other cutting tools.

WARNING: For your own safety turn switch "OFF" and remove plug from power source before removing insert.

To remove the insert.

- Make sure saw is off and unplugged.
- Lower the blade below the table surface.
- Raise blade guard.
- Loosen flat head screw.
- Lift insert from front end, and pull toward front of saw.

WARNING: To reduce the risk of injury from a thrown workpiece, blade parts, or blade contact, never operate saw without the proper insert in place. Use the sawblade insert when sawing. Use the dado/molding head insert when using a dado blade or molding head.

20. Wrench/Blade Storage...conveniently stores arbor wrenches as well as extra sawblade or dado/molding blades.

21. Cord Wrap...wrap power cord around holder and secure by attaching plug with clip to cord.

22. Sawdust Ejection Port

Your table saw is equipped with a vacuum hookup. This feature will allow you to attach any standard 2-1/2 inch diameter wet/dry vacuum hose into the hole provided for convenient sawdust removal.

WARNING: Sawdust can clog motor. Motor could ignite sawdust. Even if saw is connected to vacuum, blow out sawdust regularly.

23. Blade Guard Storage ...holds the blade guard when making non-thru cuts and transporting saw.

Blade Guard Storage

Holds the blade guard when making non-thru cuts and transporting saw. Slide blade guard in as shown. Snap bottom edge of clear basket between latches on base.

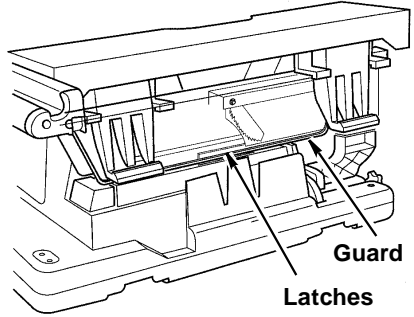

Wrench/Blade Storage

Conveniently stores arbor wrenches as well as an extra sawblade. Secure wrenches and sawblade with blade storage washer and wing nut. Extra washers are provided to separate blades and prevent tooth damage.

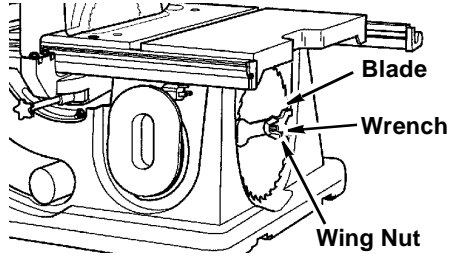

Rip Fence Storage

Securely holds the rip fence when it is not being used. To insert, place the top edge in first and twist upward to snap in place. To remove pull up on fence and rotate bottom away from saw.

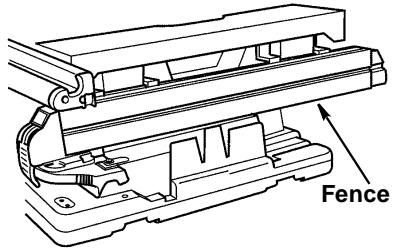

Miter Gauge Storage

Provides convenient storage for the miter gauge when it is not being used. Slide miter gauge in place as shown. To remove miter gauge release latch and lift straight up.

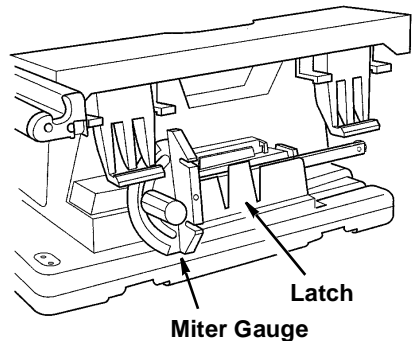

Alignment

Tools Needed



Phillips Screwdriver

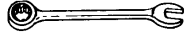

Combination Wrenches
3/8, 7/16 In., 1/2 In., 9/16 In.

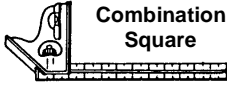

Combination Square



Hex "L" Wrenches
3/32 In., 5/32 In., 3/16 In.

Combination Square must be true. Check its accuracy as shown below.

Draw light line on board along edge

Select the straight edge of 3/4" thick board. This edge must be perfectly straight.

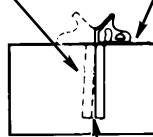

NOTE: The square and straight edge are used to align the saw. They must be accurate if the saw is to be aligned properly.

Should be no gap or overlap here when square is flipped over in dotted position.

Remove Foam Motor Support

A block of foam was placed under the motor at the factory for shipping. Lift up one edge of the saw base and remove the foam.

Checking Table Insert

WARNING: To reduce the risk of injury from accidental start, make sure switch is "OFF" and plug is not connected to power source outlet.

1. Insert should be flush with table top. Check as shown. Loosen flat head screw that holds insert and adjust the four set screws as necessary. Tighten flat head screw. Do not tighten screw to the point where it bends the insert.

CAUTION: Insert must be even with the table surface. Inserts too high or low can let the workpiece "snag" or catch on uneven edges. Workpiece could twist and kickback.

2. To remove insert.
 - a. Make sure saw is off and unplugged.
 - b. Loosen flat head screw.
 - c. Lift insert from front end, and pull toward front of saw.
3. To replace insert.
 - a. Make sure saw is off and unplugged.
 - b. Place insert into insert opening in table and push toward rear of saw to engage spring clip and until keyslot in insert will drop over flat head screw. Tighten screw.
 - c. Do not tighten screw to the point where it bends the insert.

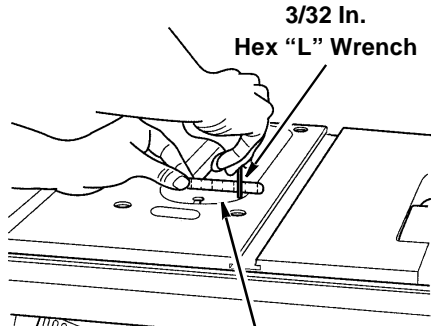
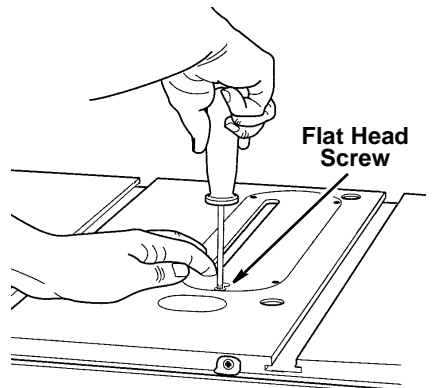

Table Insert



Checking Heeling Adjustment or Parallelism of Sawblade to Miter Gauge Groove

While cutting, the material must move in a straight line parallel to the sawblade. Therefore, both the miter gauge groove and the rip fence must be parallel to the sawblade.

WARNING: The blade must be parallel to the miter gauge groove. Misaligned blades could bind on workpiece. Workpiece could suddenly kickback. You could be cut or hit.

If the sawblade is not parallel to the miter gauge groove, the blade will bind at one end of the cut. This is known as "Heeling".

WARNING: To reduce the risk of injury from accidental start, make sure switch is "OFF" and plug is not connected to power source outlet.

To check for parallelism:

1. Raise blade all the way up.
2. Mark an "X" on one of the teeth which is set (bent) to the right.
3. Place the head of a combination square in the groove. Adjust blade of square so that it just touches the tip of the marked tooth.
4. Move square to rear, rotate blade to see if marked tooth again touches blade of square.
5. If tooth touches square the same amount at front and rear, sawblade is parallel to miter gauge groove.
6. If tooth does not touch the same amount, the mechanism underneath must be adjusted to make the blade parallel to groove.

WARNING: To reduce the risk of injury from accidental start, make sure switch is "OFF" and plug is not connected to power source outlet.

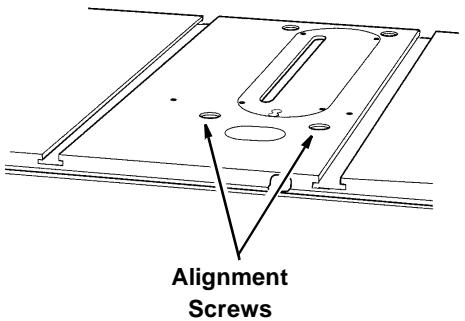
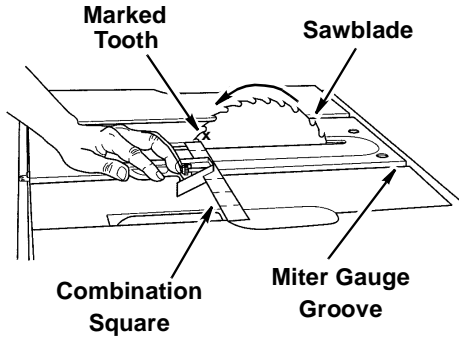

Alignment (continued)

NOTE: Always review the section "Checking Blade Parallel to the Miter Gauge Groove" before proceeding with this section.

7. Loosen 1/2 turn the four alignment screws in the top of table next to the sawblade. This will allow the mechanism below the table to be shifted sideways.

CAUTION: Blade tips are sharp, to move, grasp blade as shown to avoid injury.

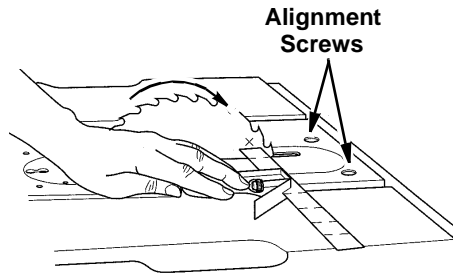

8. Push on side of blade and move it to either the right or left as needed to make the square touch the same amount front and rear. Tighten one screw.
9. Check with square to determine if marked tooth touches square by the same amount at front and rear.

If it does, alternately tighten the other three screws.

If it does not, loosen screw and move blade the required amount.

10. Recheck blade clearance to table insert to make sure blade does not hit at either 90 or 45 degree blade tilt.

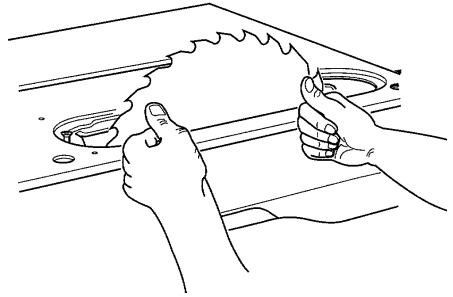

Checking Blade Tilt, or Squareness of Blade to Table

When the bevel pointer is pointing directly to the "0" mark on the bevel scale, the sawblade should make a square cut 90° to the table.

WARNING: For your own safety, turn switch "OFF" and remove plug from power source outlet.

To Check For Squareness, 90° Position

1. Raise blade all the way up.
2. Loosen the blade tilt lock lever and push the elevation wheel in and to the left as far as possible and tighten the blade tilt lock lever.
3. Place the square against blade. Make sure square is not touching the tip of one of the saw teeth.

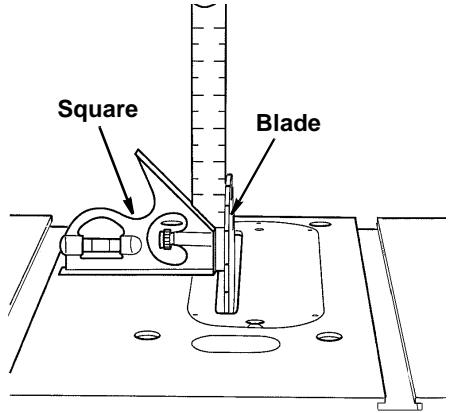

A. If blade is square to table

1. Check pointer. If pointer does not point to the "0" mark on the bevel scale, loosen the pointer adjusting screw and adjust pointer using medium screwdriver. Retighten screw.

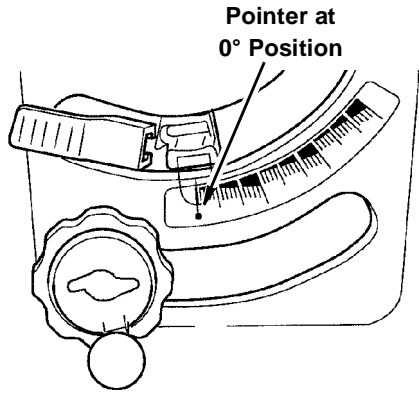

B. If blade is not square to table, the 90° stop screw must be adjusted.

1. Loosen 90° stop screw three to four turns using 5/32 inch hex "L" wrench.
2. Loosen blade tilt lock lever. Turn handwheel until blade is 90° to the table. Tighten blade tilt lock lever.
3. Screw 90° stop screw in until it stops. Check for squareness and readjust screw, if necessary.
4. Check pointer as described in step A.

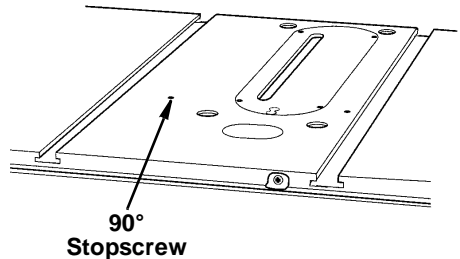

Alignment (continued)

To check for alignment, 45° Position

1. Loosen the blade tilt lock lever and push elevation wheel in and to the right as far as possible and tighten the blade tilt lock lever.
2. Place an accurate square against blade. Make sure square is not touching the tip of one of the saw teeth.

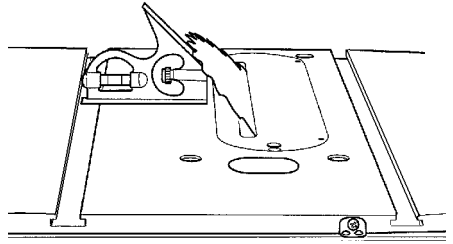

A. If blade is 45° to table;

1. Check pointer. If pointer does not point to the 45° mark on the scale, the scale must be adjusted.
2. Loosen two screws on scale and adjust scale up or down until pointer points to 45° mark.

Scale Screws

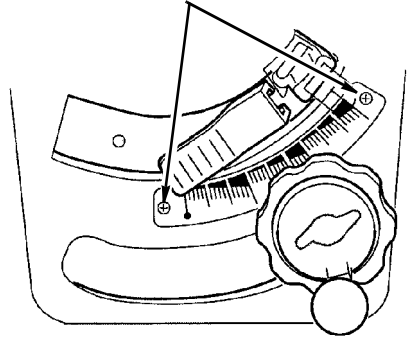

B. If blade is not 45° to table, stop screw and scale must be adjusted.

1. Loosen 45° stop screw three to four turns using 5/32 inch set-screw wrench.
2. Loosen blade tilt lock lever. Turn handwheel until blade is 45° to the table. Tighten blade tilt lock lever.
3. Screw 45° stop screw in until it stops. Check once again and readjust screw, if necessary.
4. Check pointer as described in step A above.

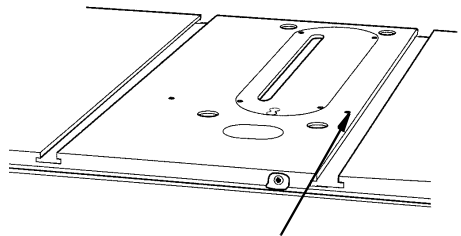

45°
Stopscrew

Adjusting Rip Fence Guide Bars

Aligning Rip Fence Guide Bars

1. Position rip fence over right end of main table. While holding up rear of rip fence engage front end of rip fence onto the front guide bar. Now lower rip fence down onto table.
2. Open owners manual so that 8 pages are separated from the rest of the book. Use these pages like a feeler gage to set the spacing between the bottom of the fence and the table top.
3. Rip fence should clear saw table surface just enough to allow eight pages to slide back and forth under rip fence. If rip fence is too high or too low, loosen the four nuts under the table and the screw that secures rip scale at front of main table. Release table lock, position fence inside table extension lock lever. Adjust front bar up and down as required. Wrench tighten front right nut only.
4. Adjust rear guide bar, as noted above. Wrench tighten rear right nut.
5. Reposition fence over left end main table.
6. Adjust front guide bar up or down as needed so the rip fence clears the saw table surface just enough to allow the 8 pages of the owners manual to slide back and forth underneath the rip fence. Wrench tighten the front left nut first and then the other remaining two nuts at the front of the main table.
7. Adjust rear guide bar, as noted above. Wrench tighten the rear left nut first then the other two nuts at the rear of the main table.
8. Slide fence left and right over main table to insure clearance.
9. Tighten rip scale hold down screw.

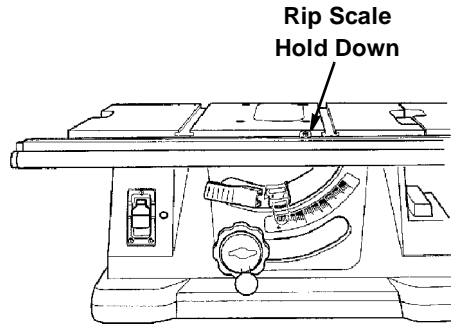
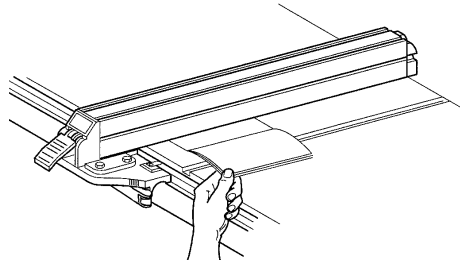
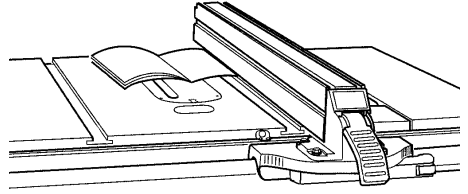
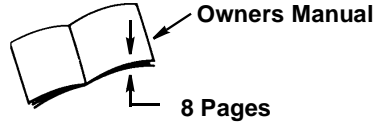

Alignment (continued)

Aligning Sliding Table Extension

1. Lock table extension lever.
2. Loosen the four nuts underneath the sliding table extension.
3. Use a combination square to make sure the top of the sliding table extension is the same height as the main table.
4. Tighten four nuts. Recheck and readjust if necessary.

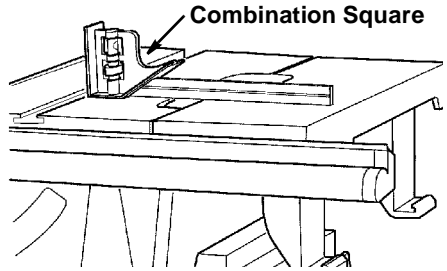

Rip Fence Alignment Adjustment

WARNING: A misaligned fence can cause kickbacks and jams. To reduce the risk of injury, follow these instructions until the fence is properly aligned.

The rip fence must be PARALLEL with the sawblade and miter gauge grooves. Clean any debris off the fence guide bars. Move fence until it is along the side of the right miter gauge groove and lock it. It should be parallel to groove. If it is not:

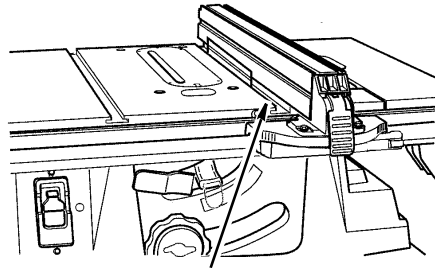

Miter Gauge Groove

- a. Unlock fence.
- b. Loosen the four hex head screws located to each side of the rip fence handle.
- c. Place the blade of the combination square in the right miter gauge groove as shown.
- d. Slide the fence against the blade of the combination square as shown. Carefully lock the fence in this position.
- e. Alternately tighten the hex head screws.
- f. Recheck alignment.
- g. Repeat steps as needed until rip fence is correctly aligned.

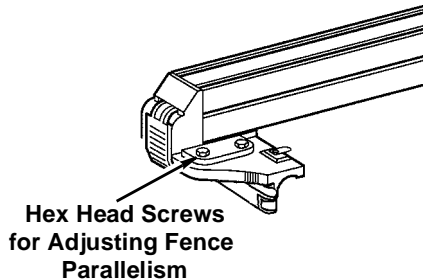

Rip Fence Lock Lever Adjustment

The rip fence lock lever, when locked down, should hold the rip fence securely. The lever should not be difficult to push down and lock.

To assure proper fence lock adjustment:

- Raise lock lever and push fence head toward rear of saw.
- Hold fence head down onto front guide bar while lifting rear of fence up and down.
- Tighten adjusting nut until fence clamp just barely touches rear guide bar.
- This should provide the best fence adjustment possible without over tightening.

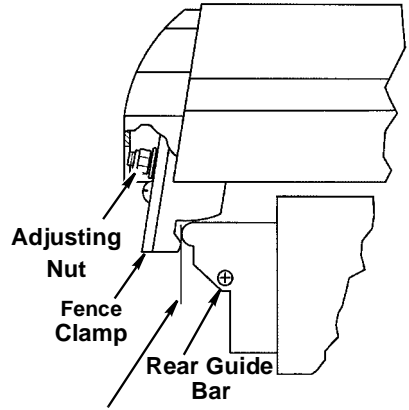

**Fence Clamp and Rear Guide Bar
Should Barely Touch When
Fence is Raised**

Adjusting Rip Indicator

- Raise the blade up approximately 1".
- Use a ruler to position the rip fence 6" to the right of the blade as shown. Lock the rip fence.
- The rip indicator should read 6".

If not:

- Slightly loosen the Phillips head screw.
- Slide the indicator left or right as required.
- Tighten the Phillips head screw.

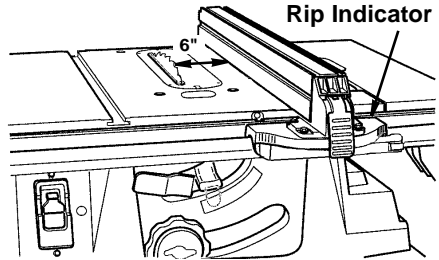

Alignment (continued)

Checking Sliding Table Extension

Lock the table extension lock lever. Pull-push on the sliding table extension. It should not move.

WARNING: To reduce the risk of thrown workpiece, do not use with extension lock lever unlocked.

If the sliding table extension moves when locked:

1. Release the table extension lock lever.
2. Find the front hex coupling located underneath the front table.
3. Loosen the hex locking nut.
4. Turn the hex coupling counterclockwise.
5. Lock the table extension lock. Pull-push on the sliding table extension. Readjust hex coupling if necessary. Tighten the hex locking nut against coupling.

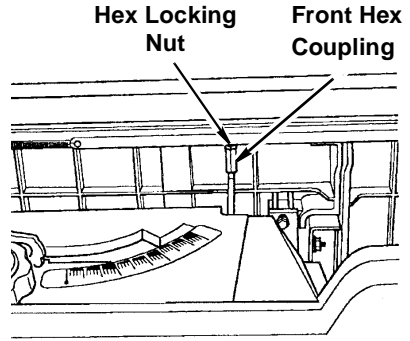

Installing Blade Guard

1. Locate the blade guard.
2. Two (2) locator pins are on the blade guard. These locator pins fit into matching holes on a bracket located on the table saw trunnion.
3. Turn the blade guard locking knob clockwise to securely attach the blade guard in place.

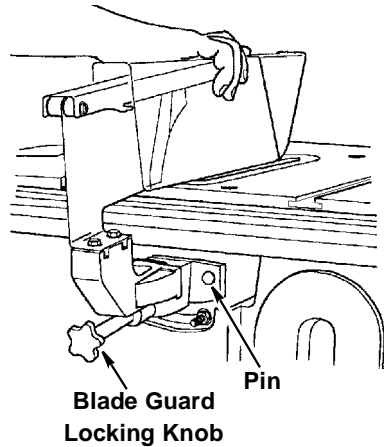

Aligning Blade Guard

IMPORTANT: To work properly, the spreader must always be adjusted so the cut workpiece will pass on either side of the spreader without binding or skewing to the side.

NOTE: The spreader is thinner than the width of the cut (kerf) by approximately six thicknesses of paper.

1. Raise blade all the way up, making sure it is square with table.
2. Use a wrench to loosen the screw that secures the spreader support to the spreader mount.
3. Raise blade guard. Lift up both anti-kickback pawls. Insert a large set screw wrench in the notches of the pawls to hold the pawls out of the way.
4. Place a square against the spreader as shown. Use a wrench to tighten the screw.
5. Make two folds in a small piece (6 x 6 inch) of ordinary **newspaper** making three thicknesses. The folded paper will be used as "spacing gauge".
6. Using 7/16 wrench loosen the 1/4-20 hex head screws so the spreader can slide sideways.
7. Place rip fence on the right hand side of table. **Carefully** move it against blade so that it is parallel to the blade, and just touches tips of saw teeth. Tighten rip fence lock lever.
8. Insert folded paper between spreader and fence.
9. Hold spreader flat against folded paper and fence. Tighten screws using 7/16 inch wrench.
10. To remove blade guard and spreader, loosen the blade guard locking knob. **Do not loosen other screws.** This allows you to remove and replace the guard for non-through cuts without disturbing the spreader alignment.

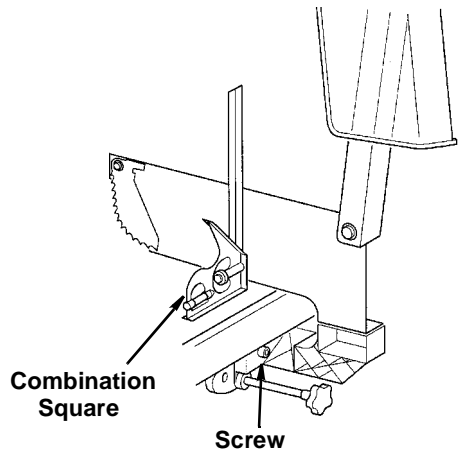
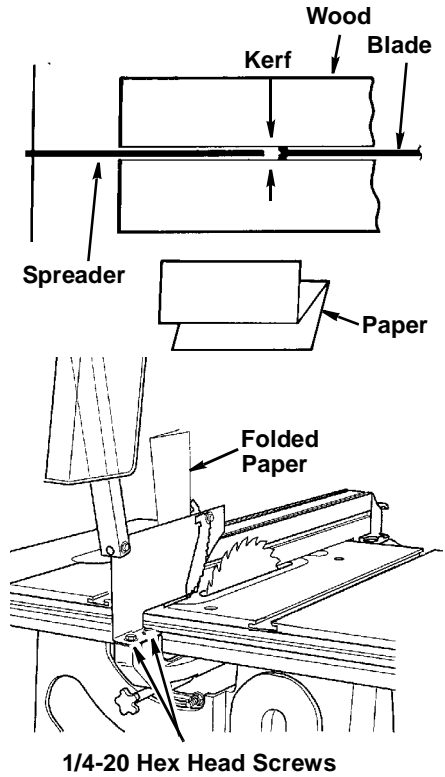

Alignment (continued)

Removing and Installing Sawblade

WARNING: To reduce the risk of injury from accidental start, turn switch “OFF” and remove plug from power source outlet before removing or installing sawblade.

- Raise blade guard, remove insert, elevate blade to its highest point.
- To remove blade, hold arbor wrench securely, pull arbor nut wrench towards the front of the table.
- To tighten arbor nut, hold arbor wrench securely, push arbor nut wrench towards the rear of the table.

When installing the blade, make sure the teeth are pointing toward the front of the saw and that the blade and collars are clean, and free from any burrs. The hollow side of the collar must be against the blade.

Always tighten the arbor nut securely.

NOTE: When using the dado or molding head, it is not necessary to install the outer (loose) blade collar.

- Lower the blade below the table.
- To replace insert, place insert into opening in table and push toward rear of saw to engage rear spring on insert and until key slot in insert will drop over screw. Tighten screw. Do not tighten screw to the point where it will deflect the insert.

WARNING: To reduce the risk of injury from a thrown workpiece, blade parts, or blade contact, never operate saw without the proper insert in place. Use the sawblade insert when sawing. Use the proper size dado/molding insert for dado blades and molding heads.

WARNING: For your own safety, turn switch “OFF” and remove plug from power source outlet before making any adjustments.

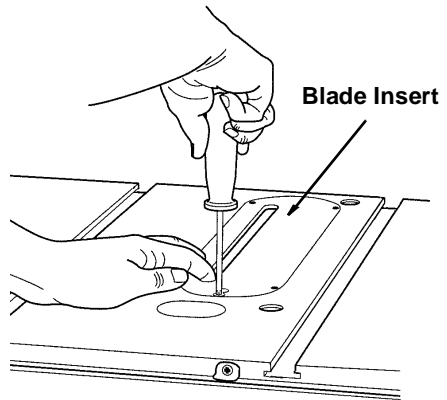
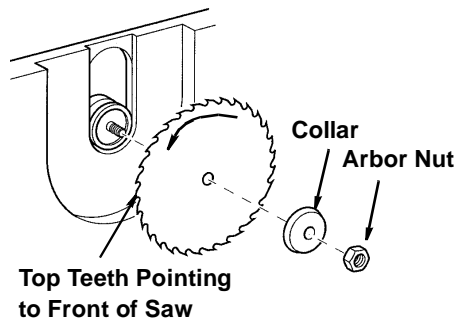
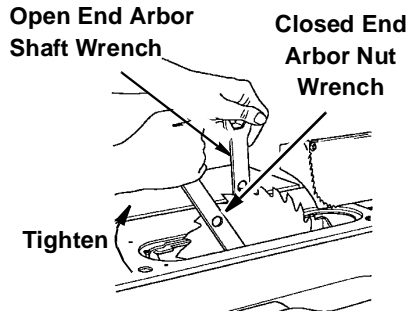

Miter Gauge Alignment

NOTE: The graduations are manufactured to very close tolerances which provide ample accuracy for fine woodworking. In some cases where extreme accuracy is required, when making angle cuts, for example, make a trial cut and then recheck it.

There are adjustable screw stops for the stop pin at 0° and 45° right and left positions for conveniently setting the miter gauge to cut miters at these standard angles.

Adjusting Stop Screws

- A. Loosen lock nut of screw for 0° stop.
- B. Place 90° square against the miter gauge bar and the face of the miter gauge head.
- C. If adjustment is needed loosen handle of miter gauge. Adjust miter gauge head flush to square. Tighten lock knob.
- D. Adjust stop screw until it rests against the stop pin and tighten lock nut.
- E. Adjust 45°, left and right using a 45° triangle or a protractor or a square using the above procedure.

The miter gauge head should swivel smoothly on the bar after the knob is loosened. To adjust this swivel movement:

- A. Loosen the knob.
- B. Loosen set screw with a 2.5mm hex wrench.
- C. If the head is too loose turn the flat-head screw in a clockwise direction. If the head is too tight and will not swivel smoothly turn the flathead screw counterclockwise.
- D. Tighten set screw.

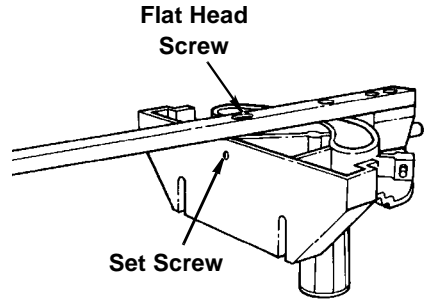
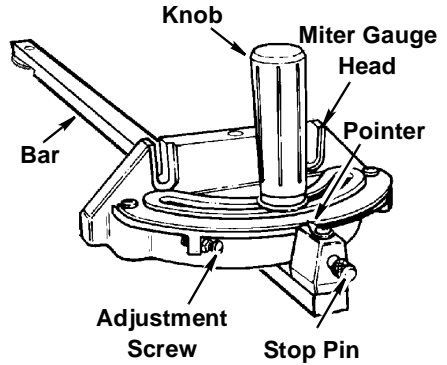

Alignment (continued)

Marking the Ind-I-Cut:

- With blade 90° (square to table) and miter gauge in left groove, cross cut a piece of wood holding the wood firmly against miter gauge.
- Pull miter gauge back until freshly cut edge of wood is over disk. Using a sharp pencil, mark a line on disk at freshly cut edge of wood.
- With miter gauge in right hand groove, follow same procedure and mark another line on disk.
- These lines indicate the “path” of the cut (kerf) made by the sawblade.
- When cutting the workpiece, line up mark on workpiece with line on disk.

NOTE: When the blade is changed, or a dado/molding head installed these lines can be erased and reset.

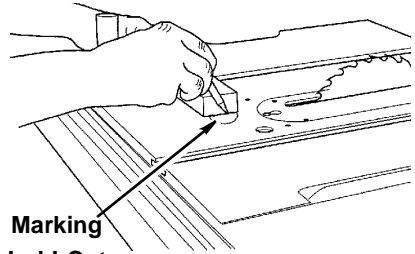

**Marking
Ind-I-Cut**

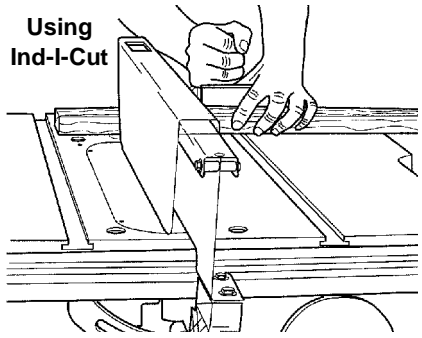

**Using
Ind-I-Cut**

Adjusting Bevel Lock

- Release blade tilt lock lever and bevel blade to 45°.
- Lock blade tilt lock lever, push in to disengage the outer hub of the elevation/bevel handwheel and with moderate force attempt to move handwheel toward the 0° bevel.
- If blade tilt mechanism cannot be moved, no additional adjustment is necessary.
- If blade tilt mechanism can be moved adjust the blade tilt lock nut by rotating clockwise 1/4 turn.
- Repeat steps 3 and 4 as necessary.
- Release hub of the elevation/bevel handwheel and move blade tilt mechanism back to 0°.

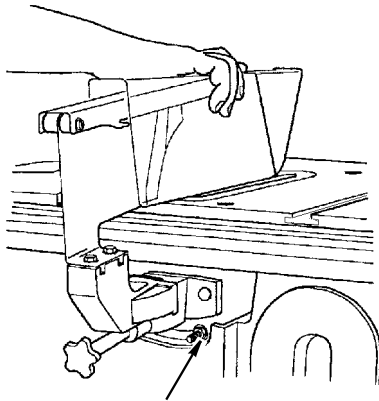

**Blade Tilt
Lock Nut**

Mounting Your Saw

Mounting Table Saw to Workbench or Legset

WARNING: To reduce the risk of injury from accidental start, make sure switch is "OFF" and plug is not connected to power source outlet.

WARNING: To reduce the risk of injury from kickback or saw movement the saw must be properly secured to a sturdy workbench, cabinet or legset. Casters if provided on the cabinet or legset must be locked during saw operation. If there is any tendency for the saw to move or rock during operation, this must be corrected immediately.

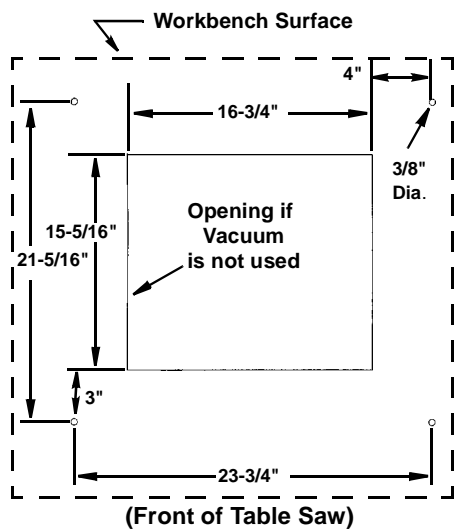

Diagram of Workbench Mounting Holes

If table saw is to be used in a permanent location, it should be fastened securely to a firm supporting surface such as a workbench, or legset using the mounting holes.

Workbench Mounting Using Hardware

When mounting table saw to a workbench and using a vacuum hookup, holes should be drilled through the supporting surface of the workbench using the dimensions illustrated.

If a vacuum is not used, an opening must be made in the workbench using the dimensions illustrated, so the sawdust can fall away from the saw base area.

Table Saw Mounting Procedures

1. Locate the proper hole mounting diagram for your desired type of table saw mounting.
2. Mark the hole locations and cutout opening if vacuum is not used. Drill the holes and cut out the area to allow sawdust to fall away from the base if a vacuum is not being utilized.

3. Place the table saw on the mounting surface and align the four holes.
4. Insert four (4) 1/4-20 screws that are long enough for washers and nuts which will properly secure the table saw to the mounting surface.

NOTE: Mounting hardware (bolts, nuts, washers etc.) are not supplied with the saw.

Mounting Your Saw (continued)

Mounting Table Saw to RIDGID Universal Power Tool Legset #AC9910

1. Assemble legset per instructions.
2. Locate the four (4) "TS" layout points on the particle board tables.
3. Drill the four (4) above holes.
4. Insert four (4) 1/4-20 screws that are long enough for washers and nuts which will properly secure the table saw to the legset. Tighten hardware.

NOTE: Mounting hardware (bolts, nuts, washers, etc.) are not supplied with the saw.

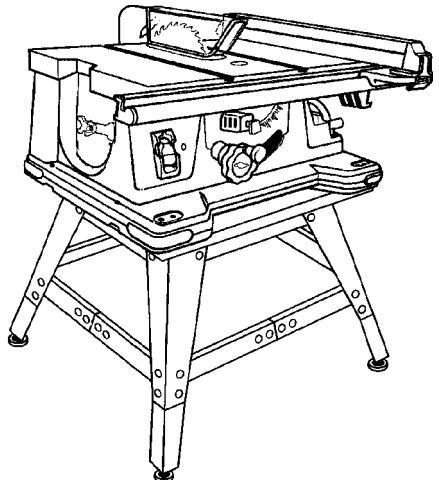

Workbench Mounting Using "C" Clamps

An alternative method of securing your table saw is to fasten the saw base with "C" clamps.

1. Follow instructions for mounting to workbench, substitute "C" clamps at each mounting screw location.
2. Securely clamp saw to workbench using four "C" clamps, as shown.

Supporting surface where saw is to be mounted should be examined carefully after mounting to insure that no movement can occur during use. If any tipping, sliding or walking is noted, secure the workbench or cabinet before operating the table saw.

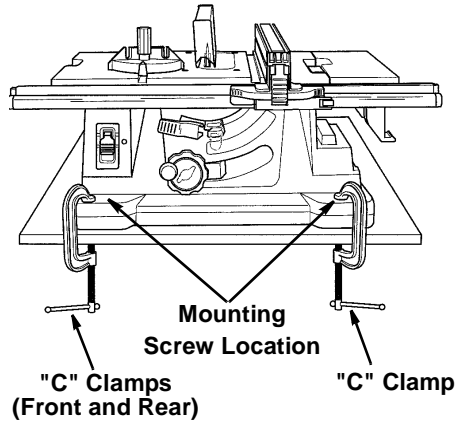
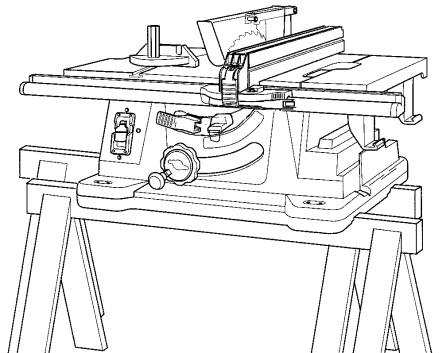

Diagram of Clamping Table Saw to Workbench

Supporting Table Saw with Sawhorses

The table saw has provisions for being supported by sawhorses. The sawhorse can be built with the 2" x 4" crosspieces either vertical or horizontal. Make sure the sawhorses are secure. Holes for securing unit to sawhorse(s) are provided.



Safety Instructions for Basic Saw Operations

Before Each Use

Inspect your saw.

- To reduce the risk of injury from accidental starting, turn the switch off, unplug the saw, and remove the switch key before raising or removing the guard, changing the cutting tool, changing the setup, or adjusting anything.
- Check for alignment of moving parts, binding of moving parts, breakage of parts, saw stability, and any other conditions that may affect the way the saw works.
- If any part is missing, bent or broken in any way, or any electrical part does not work properly, turn the saw off and unplug the saw.
- Replace damaged or missing parts before using the saw again.
- Use the sawblade guard, spreader and anti-kickback pawls for any thru-sawing (whenever the blade comes through the top of the workpiece). Make sure the anti-kickback pawls work properly. Make sure the spreader is in line with sawblade.
- Remove adjusting keys and wrenches. Form a habit of checking for and removing keys and wrenches from table top before turning saw on.
- Make sure all clamps and locks are tight and no parts have excessive play.

To Reduce the Risk of Injury From Jams, Slips Or Thrown Pieces (Kickbacks Or Throwbacks)

Inspect Your Blade.

- Choose the right blade or cutting accessory for the material and the type of cutting you plan to do.
- Never use grinding wheels, abrasive cutoff wheels, friction wheels (metal cutting blades) wire wheels or buffing wheels. They can fly apart explosively.
- Cut only wood, wood like or plastic materials. Do not cut metal.
- Choose and inspect your cutting tool carefully:
 - To reduce the risk of cutting tool failure and thrown shrapnel (broken pieces of blade), use only 10" or smaller blades or other cutting tools marked for speeds of 5000 rpm or higher.
 - Always use unbroken, balanced blades designed to fit this saw's 5/8 inch arbor.
 - When thru-sawing (making cuts where the blade comes through the workpiece top), always use a 10 inch diameter blade. This keeps the spreader in closest to the blade.
 - Do not over tighten arbor nut. Use arbor wrenches to "snug" it securely.
 - Use only sharp blades with properly set teeth. Consult a professional blade sharpener when in doubt.
 - Keep blades clean of gum and resin.
 - Never use the saw without the proper blade insert.

Inspect your work area.

- Keep work area clean.
- Cluttered areas and benches invite accidents. Floor must not be slippery from wax or sawdust.

Safety Instructions for Basic Saw Operations (continued)

- To reduce the risk of burns or other fire damage, never use the saw near flammable liquids, vapors or gases.
- To reduce the risk of injury, don't do layout, assembly, or setup work on the table while blade is spinning. It could cut or throw anything hitting the blade.
- Never cut **Freehand**. Always use either a rip fence, miter gauge or fixture to position and guide the work, so it won't twist or bind on the blade and kickback.
- Make sure there's no debris between the workpiece and its supports.

Plan your work

- Use the right tool. Don't force tool or attachment to do a job it was not designed for.

Inspect your workpiece.

- Make sure there are no nails or foreign objects in the part of the workpiece to be cut.
- When cutting irregularly shaped workpieces, plan your work so it will not slip and pinch the blade:
- A piece of molding for example, must lie flat or be held by a fixture of jig that will not let it twist, rock or slip while being cut. Use jigs or fixtures where needed to prevent workpiece shifting.
- Use a different, better suited type of tool for work that can't be made stable.

Plan your cut.

- To reduce the risk of kickbacks and throwbacks which occur when a part or all of the workpiece binds on the blade and is thrown violently back toward the front of the saw:

- Use extra caution with large, very small or awkward workpieces.
- Use extra supports (tables, saw horses, blocks, etc.) for any workpieces large enough to tip when not held down to the table top. Never use another person as a substitute for a table extension, or as additional support for a workpiece that is longer or wider than the basic saw table, or to help feed, support or pull the workpiece.
- Never confine the piece being cut off, that is, the piece not against the fence, miter gauge or fixture. Never hold it, clamp it, touch it, or use length stops against it. It must be free to move. If confined, it could get wedged against the blade and cause a kickback or throwback.
- Never cut more than one workpiece at a time.
- Never turn your table saw "ON" before clearing everything except the workpiece and related support devices off the table.

Plan Ahead To Protect Your Eyes, Hands, Face and Ears

Dress for safety

- Do not wear loose clothing, gloves, neckties or jewelry (rings, wrist watches). They can get caught and draw you into moving parts.
- Wear nonslip footwear.
- Tie back long hair.
- Roll long sleeves above the elbow.
- Noise levels vary widely. To reduce the risk of possible hearing damage, wear ear plugs or muffs when using table saw for hours at a time.

- Any power saw can throw foreign objects into the eyes. This can result in permanent eye damage. Always wear safety goggles, not glasses, complying with ANSI Z87.1 (or in Canada CSA Z94.3-99) shown on package. Everyday eyeglasses have only impact resistant lenses. They are not safety glasses. Safety goggles are available at many local retail stores. Glasses or goggles not in compliance with ANSI or CSA could seriously hurt you when they break.



- For dusty operations, wear a dust mask along with safety goggles.

Plan the way you will push the workpiece through.

- **Never pull the workpiece through.** Start and finish the cut from the front of the table saw.
- **Never put your fingers or hands in the path** of the sawblade or other cutting tool.

- **Never reach in back** of the cutting tool with either hand to hold down or support the workpiece, to remove wood scraps, or for any other reason.
- Avoid hand positions where a sudden slip could cause fingers or a hand to move into a sawblade or other cutting tool.
- Don't overreach. Always keep good footing and balance.
- Push the workpiece against the rotation of the blade, never feed material into the cutting tool from the rear of the saw.
- Always push the workpiece all the way past the sawblade.
- As much as possible, keep your face and body to one side of the sawblade, out of line with a possible kickback or throwback.
- Set the cutting tool as low as possible for the cut you're planning.

Reduce the Risk of Accidental Starting.

- Make sure switch is "OFF" before plugging saw into a power outlet.

Whenever Sawblade Is Spinning

WARNING: Don't allow familiarity (gained from frequent use of your table saw) cause a careless mistake. Always remember that a careless fraction of a second is enough to cause a severe injury.

- Before actually cutting with the saw, watch it while it runs for a short while. If it makes an unfamiliar noise or vibrates a lot, stop immediately. Turn the saw off. Unplug the saw. Do not restart until finding and correcting the problem.

- Make sure the top of the arbor or cutting tool turns toward the front of the saw.

Keep Children Away.

- Keep all visitors a safe distance from the table saw.
- Make sure bystanders are clear of the table saw and workpiece.

Don't Force Tool.

- Let the blade reach full speed before cutting.
- It will do the job better and safer at its designed rate.

Safety Instructions for Basic Saw Operations (continued)

- Feed the workpiece into the saw only fast enough to let the blade cut without bogging down or binding.

Before freeing jammed material.

- Turn switch “OFF”.
- Wait for all moving parts to stop.
- Unplug the saw.
- Check blade, spreader and fence for proper alignment before starting again.
- **To reduce the risk of throwback of cut off pieces.**
- Use the guard assembly.

To remove loose pieces beneath or trapped inside the guard.

- Turn saw “OFF”.
- Remove switch key.
- Wait for blade to stop before lifting the guard.

Before Leaving The Saw.

- Turn the saw off.
- Wait for blade to stop spinning.
- Unplug the saw.
- Make workshop child-proof. Lock the shop. Disconnect master switches. Remove the yellow switch key. Store it away from children and others not qualified to use the tool.

Work Feed Devices

Before cutting any wood on your saw, study all of the “Basic Saw Operations”. As you learn new table saw woodworking techniques, you’ll see that many types of cuts need different support and feeding devices, known as jigs or fixtures. They can help you make cuts more accurately. By helping to steady the workpiece and keep you away from the blade, they can help you safely use your saw for certain cuts.

Many people custom build their own jigs and fixtures. Jigs and fixtures are often designed for a particular cut.

You can use your table saw to easily make many jigs and fixtures. To get you started, we’ve included instructions for some simple ones. After you have made a few practice cuts, make up these jigs before starting any projects. The use of these devices is explained in “Basic Saw Operations” section.

Push Stick

Make the push stick from a piece of solid wood. Use a piece of 1 x 2 (3/4" x 1-5/8" actual) by 15" long.

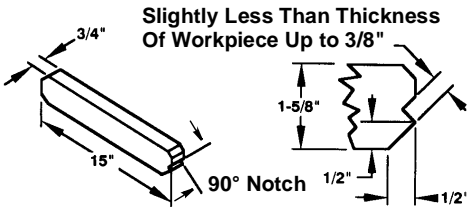

Make the featherboard from a piece of 8" x 24" x 3/4" thick solid wood

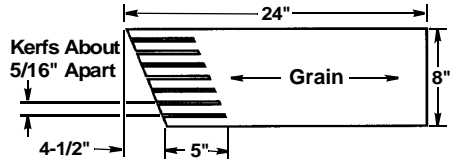

Push Block (For Use with Auxiliary Fence)

There are any number of ways to properly cut your workpieces to make a push block. The following steps describe one way you can make a push block.

Making the base:

- Start with a piece of 3/8 inch plywood at least 5-5/8 inches wide or wider and 12 inches long or longer.
- Make two ripcuts. Perform the first ripcut along the side of the 3/8" wide strip. Next, ripcut the 3/8" plywood to a width of 5-1/8".
- Crosscut the 3/8" plywood to 12" long.
- Crosscut a 2-1/2" piece off the 3/8" wide by 3/8" thick strip and save this short piece for later.

The next cuts will create the 3/8" by 9-1/2" notch in the base. Mark the long edge of the board 2-1/2" from one end. Make a crosscut into the edge on the mark, stopping about 3/4" into the board. Set the saw and rip the width to 4-3/4" along the same edge as the stopped crosscut. Stop the ripcut where the two cuts intersect. Turn off the saw and remove the base piece. The base should now measure as shown.

Material for Push Block

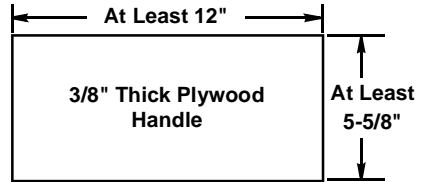
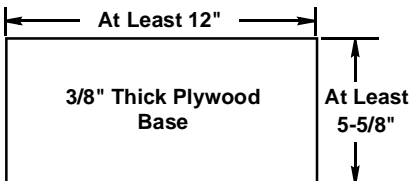

Cutting Out the Base

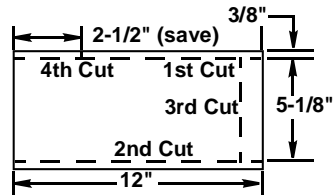

Creating the Notch

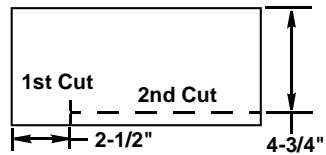

Finished Base

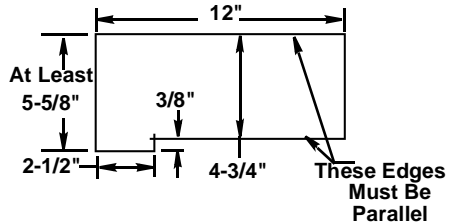

Work Feed Devices (continued)

Making the handle:

- Miter crosscut a piece of 3/4 inch thick plywood to shape and size shown:

NOTE: The mitered corners can be any size that looks like the drawing (about 1-1/2" by 1-1/2").

Putting it Together

- Using good quality woodworking glue, glue the 3/8" x 3/8" x 2-1/2" piece strip saved earlier to the base as shown.

IMPORTANT: Do not use nails or screws. This is to prevent dulling of the sawblade in the event you cut into the push block.

- Position the handle at the center of the plywood base as shown. Fasten them together with glue and wood screws.

IMPORTANT: Make sure the screw heads do not stick out from the bottom of the base, they must be flush or recessed. The bottom must be flat and smooth enough to slide along the auxiliary fence you are now ready to make.

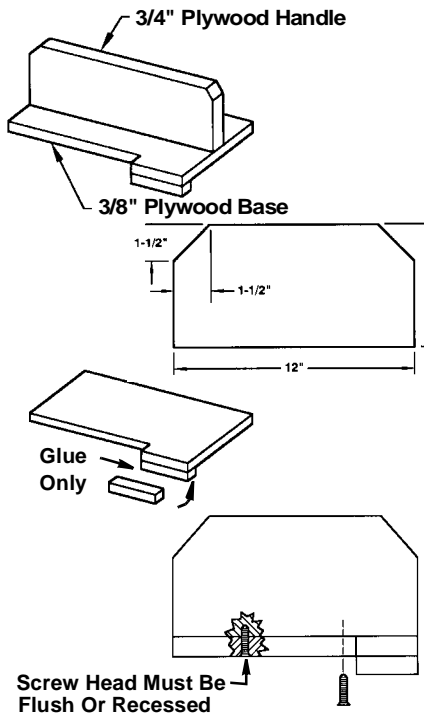

Auxiliary Fence

Making the base:

- Start with a piece of 3/8 inch plywood at least 5-1/2 inches wide or wider and 25-1/2 inches long or longer.
- Cut the piece to shape and size shown:

Making the side:

- Start with a piece of 3/4 inch plywood at least 3 inches wide or wider and 25-1/2 inches long or longer.
- Cut the piece to shape and size shown:
- Optional: Drill three (3) holes in plywood side similar to rip fence wood facing (see page 31). The plywood side may either be mounted to the rip fence using these three holes and appropriate nuts and bolts or clamped to the fence with "C" clamps.

Putting it together:

- Put the pieces together, as shown:

IMPORTANT: Make sure the screw heads do not stick out from the bottom of the base, they must be flush or recessed. The bottom must be flat and smooth enough to rest on the saw table without rocking.

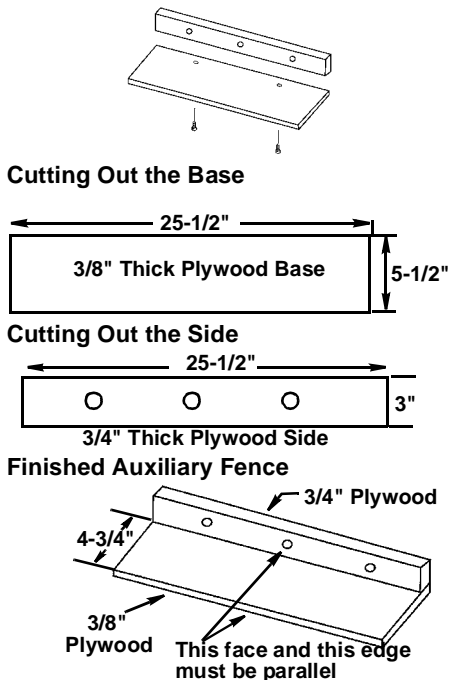

Fence Facing

Select a piece of smooth straight wood approximately 3/4 inch thick, and the same length as the rip fence.

Attach it to the fence with the three square head bolts, nuts and washers. (See "Hardware for Attaching Wood Facing") in Repair Parts Figure 4. To remove the facing, loosen the hex nuts, slide the facing toward the rear and out of the fence slot.

If the fence facing is for use with feather boards, it will need to be about 8" tall. For use with molding heads and dado blades the width should be at least 3".

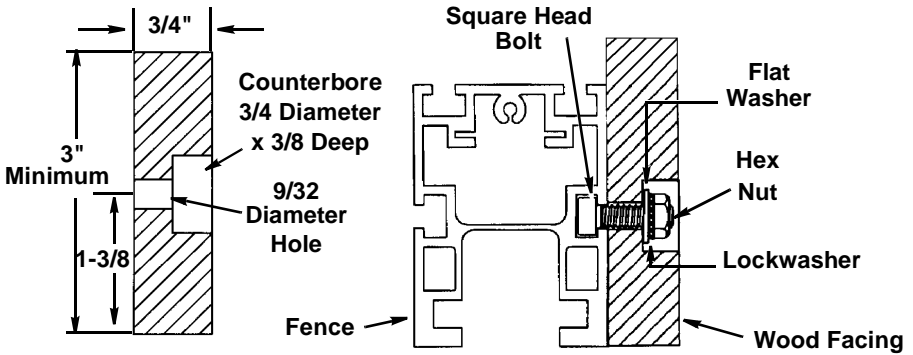
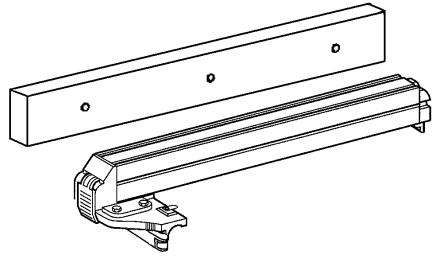

Basic Saw Operations

Using the Miter Gauge

The miter gauge is used when crosscutting, miter cutting, bevel cutting, compound miter cutting, dadoing and when rabbeting across the end of a narrow workpiece.

WARNING: For your own safety, always observe the following safety precautions in addition to the safety instructions of pages 3 thru 9 and 35 thru 38.

Additional Safety Instructions for Crosscutting

Before Starting:

- Never use the rip fence when crosscutting except as specifically instructed.

Crosscutting

Definition: A cutting or shaping operation made across the width of a workpiece.

The graduations on the miter gauge provide ample accuracy for average woodworking. In some cases where extreme accuracy is required, make a trial cut and then recheck it with a precision square, or protractor.

NOTE: The space between the miter gauge bar and the groove in the table is held to a minimum during manufacturing. For maximum accuracy when using the miter gauge, always favor one side of the groove in the table. In other words, don't move the miter gauge from side to side while cutting but keep one side of the bar riding against one side of the groove.

NOTE: Gluing a piece of sandpaper to the face of the miter gauge head can help prevent the workpiece from "creeping" while it is being cut.

The miter gauge head is locked in position by twisting the lock knob clockwise. Always tighten it securely when in use.

WARNING: To reduce the risk of blade contact or kickback, hold miter gauge properly.

- An auxiliary wood facing attached to the miter gauge can help prevent workpiece twisting and throwbacks. Attach it to the slots provided. Make the facing long enough and big enough to support your work. Make sure, however, it will not interfere with the sawblade guard.
- Use jigs or fixtures to help hold any piece too small to extend across the full length of the miter gauge face during the cut. This lets you properly hold the miter gauge and workpiece and helps keep your hands away from the blade.

While cutting:

- To reduce the risk of blade contact, always hold the miter gauge as shown in this section.

The miter gauge may be used in either of the grooves in the table.

When using the miter gauge in the left hand groove, hold the workpiece firmly against miter gauge head with your left hand, and grip the lock knob with your right hand.

When using the miter gauge in the right hand groove, hold the workpiece with your right hand and the lock knob with your left hand.

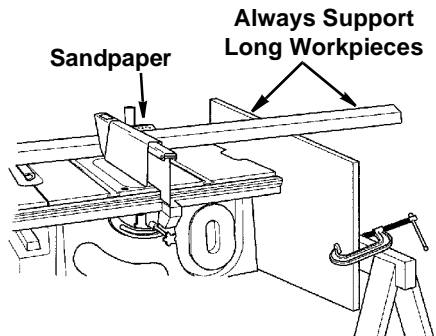

Crosscutting (continued)

Slots are provided in the miter gauge for attaching an auxiliary facing to make it easier to cut very long or short pieces. Select a suitable piece of smooth wood, drill two holes through it and attach with screws. Make sure the facing does not interfere with the proper operation of the sawblade guard.

When cutting long workpieces, you can make a simple support by clamping a piece of plywood to a sawhorse. (As seen on previous page.)

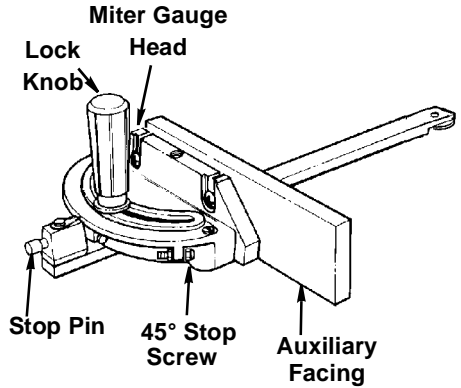

Repetitive Crosscutting

Definition: Cutting a quantity of pieces the same length without having to mark each piece.

- Follow all safety precautions and operational instructions for cross cutting.
- When making repetitive cuts from a long workpiece, make sure it is adequately supported.

WARNING: Never use the rip fence as a direct length stop because the cutoff piece could bind between the fence and the blade causing a kickback.

- When making repetitive cuts shorter than 6 inches, clamp a block of wood 3" long to the fence. Place fence at desired position to act as a length stop.
- Slide the workpiece along the miter gauge until it touches the block...hold the workpiece securely against the miter gauge.
- Make the cut...turn the saw off...remove the piece after the blade has stopped and before cutting the next piece.

WARNING: To reduce the risk of kickback from twisting the workpiece, when clamping the block make sure that the end of the block is well in front of the sawblade. Be sure it is clamped securely.

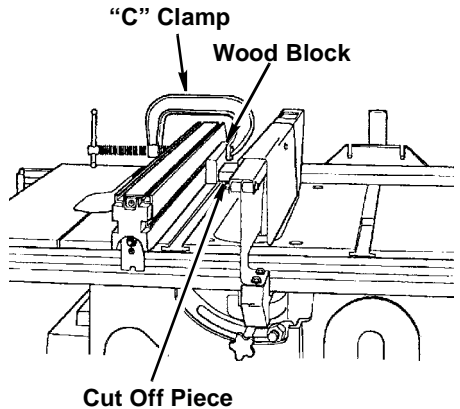

Basic Saw Operations (continued)

Miter Crosscutting

Miter cutting is cutting wood at an angle other than 90° with the edge of the wood. Follow the same procedure as you would for crosscutting.

- Adjust the miter gauge to the desired angle, and lock it.
- The miter gauge may be used in either of the grooves in the table. Make sure it is locked.
- When using the miter gauge in the left hand groove, hold the workpiece firmly against the miter gauge head with your left hand, and grip the lock knob with your right hand.
- When using the miter gauge in the right hand groove, hold the workpiece with your right hand and the lock knob with your left hand.

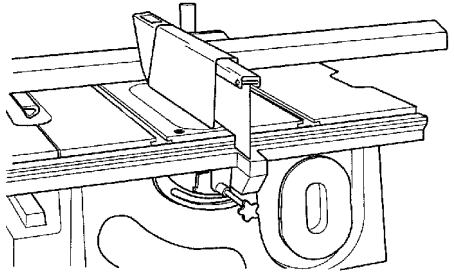

Bevel Crosscutting

Bevel crosscutting is the same as crosscutting except that the wood is cut at an angle...other than 90° with the bottom flat side of the wood.

- Adjust the blade to the desired angle.
- Always use the miter gauge in the groove to the right of the blade. It cannot be used in the groove to the left because the blade guard will interfere. Hold the workpiece with your right hand and the lock knob with your left hand.
- Use the auxiliary fence/work support for additional support of the workpiece.

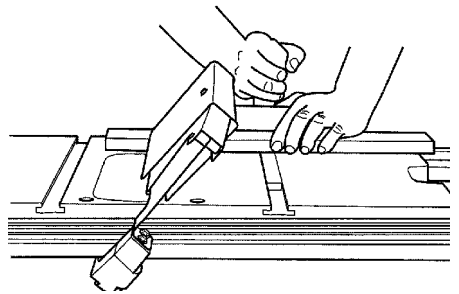

Compound Crosscutting

Compound cutting is a combination of miter cutting and bevel crosscutting. The cut is made at an angle other than 90° to both the edge and the bottom flat side of the wood.

- Adjust the miter gauge and the blade to the desired angle...Make sure miter gauge is locked.

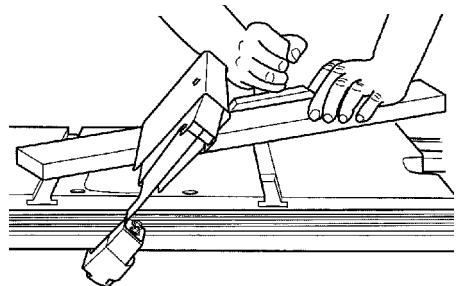

Using the Rip Fence

Ripping, bevel ripping, resawing and rabbeting are performed using the rip fence together with the auxiliary fence/work support, push stick or push block.

WARNING: For your own safety, read and always observe all safety precautions listed in manual and on saw.

Additional Safety Instructions for Rip Cuts

- Never use the miter gauge when ripping
- Use a push stick whenever the fence is 2 or more inches from the blade.
- When thru sawing, use an auxiliary fence and push block whenever the rip cut is between 1/2 and 2 inches from the blade.
- Never thru saw rip cuts narrower than 1/2 inch.
- Never rip anything shorter than 10" long.
- When using a push stick or push block, the trailing end of the workpiece must be square. A push stick or block against an uneven end could slip off or push the workpiece away from the fence.
- A featherboard can help guide the

workpiece. (See "Basic Saw Operation-Using Featherboards for Thru Sawing" section.)

- Always use featherboards for any non-thru sawing rip type cuts. (See "Basic Saw Operations-Using Featherboards for Non-thru sawing" section)

Before Starting:

- To reduce the risk of kickbacks and slips into the blade, make sure the rip fence is parallel to the sawblade.
- Before thru sawing, check the anti-kickback pawls. the pawls must stop a kickback once it has started. Replace or sharpen anti-kickback pawls when points become dull.
- Plastic and composition (like hard-board) materials may be cut on your saw. However, since these are usually quite hard and slippery, the anti-kickback pawls may not stop a kickback. Therefore, be especially careful in your setup and cutting procedures.

While Thru sawing:

- To reduce the risk of kickbacks and slips into the blade, always push forward on the section of the workpiece between the sawblade and the rip fence. Never push forward on the piece being cut off.

Basic Saw Operations (continued)

Ripping

Definition: Cutting operation along the length of the workpiece.

Position the fence to the desired width of rip and lock in place.

Before starting to rip, be sure:

1. Rip fence is parallel to sawblade.
2. Spreader is properly aligned with sawblade.
3. Anti-kickback pawls are functioning properly.

When ripping long boards or large panels, always use a work support. A simple support can be made by clamping a piece of plywood to a sawhorse.

WARNING: To reduce the risk of kickback, push forward only on the part of the workpiece that will pass between the blade and the fence.

Keep your hands out of the blade path.

Feed the workpiece by pushing forward only on the part of the workpiece that will pass between the blade and the fence.

Stop your left thumb at the front edge of the table. Finish the cut with the appropriate pusher.

Use the micro-adjust mechanism to make fine adjustments to the rip fence. To move the rip fence push in on the micro-adjust knob and rotate.

Once the trailing end is on the table:

When "width of rip" is 2" or wider, use the push stick to push the work all the way past the blade.

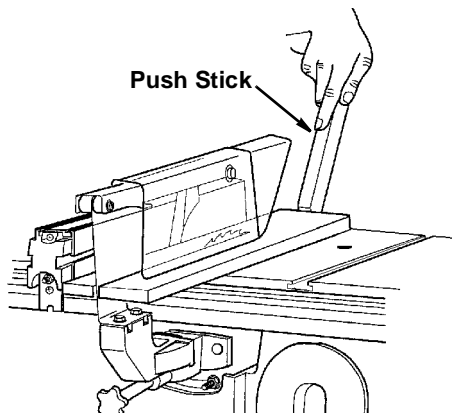
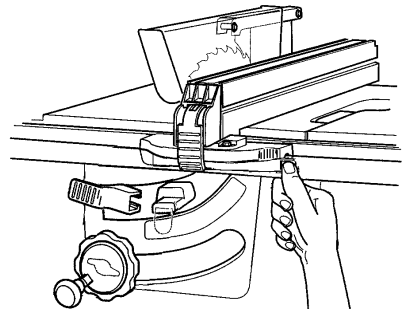
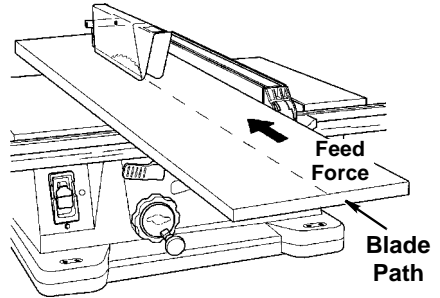
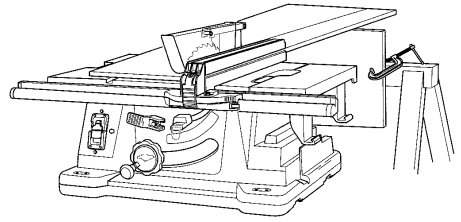

Ripping (continued)

When “width of rip” is narrower than 2” the push stick cannot be used because the guard will interfere...use the auxiliary fence and push block.

Attach auxiliary fence to rip fence with two “C” clamps or use “T” slot and hardware.

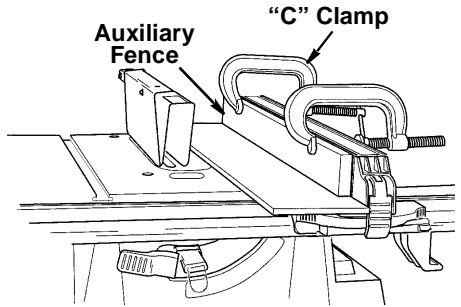

Feed the workpiece by hand along the auxiliary fence until the end is approximately 1” past the front edge of the table. Continue to feed using the push block.

Hold the workpiece in position and install the push block by sliding it on top of the auxiliary fence/work support (this may raise guard).

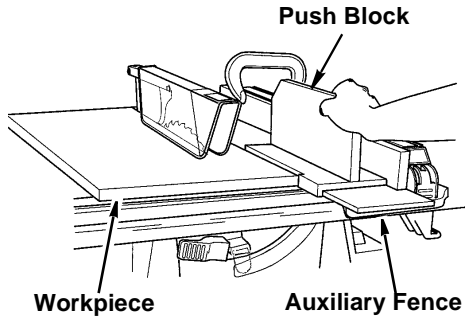

WARNING: To reduce the risk of injury from blade contact never thru saw cuts narrower than 1/2” wide.

Narrow strips thicker than the auxiliary fence/work support may enter the guard and strike the baffle. Carefully raise guard only enough to clear the workpiece. Use push block to complete cut.

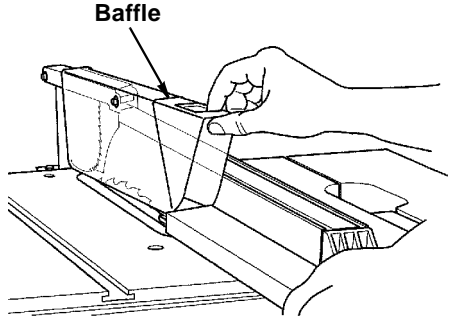

Bevel Ripping Narrow Work

When bevel ripping material 6” or narrower, use fence on the right side of the blade only. This will provide more space between the fence and the sawblade for use of a push stick. If the fence is mounted to the left, the sawblade guard may interfere with proper use of a push stick.

Basic Saw Operations (continued)

Using Featherboards for Thru Sawing

Featherboards are not employed for thru sawing operations when using the miter gauge.

Featherboards are used to keep the work in contact with the fence and table as shown, and to help stop kickbacks.

Add a 7-1/2" high flat facing board to the fence, the full length of the fence. The facing board may either be "C"-clamped to the rip fence or held in place with appropriate nuts and bolts (see "Workfeed Devices" section).

Mount featherboards to facing board and table as shown, so that leading edges of featherboards will support workpiece.

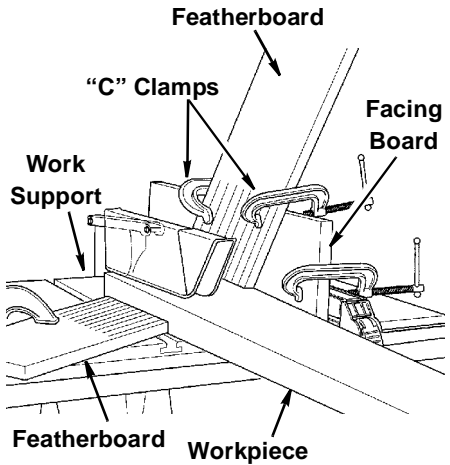

WARNING: Make sure the featherboard against the edge presses only on the uncut portion (in front of the blade). It might otherwise pinch the blade in the kerf and cause a kickback.

Before starting the operation (switch "OFF" and blade below table surface):

1. Install featherboards so they exert pressure on the workpiece; be positive they are securely attached.
2. Make sure by trial that the featherboards will stop a kickback if one should occur.

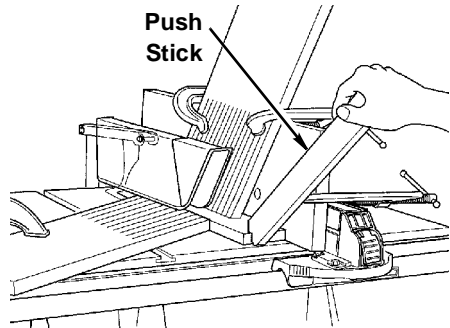

Using Featherboards for Non-Thru Sawing

Featherboards are not employed during non-thru sawing operations when using the miter gauge.

Use featherboards for all other non-thru sawing operations (when sawblade guard must be removed). Featherboards are used to keep the work in contact with the fence and table as shown and to stop kickbacks.

Add a 7-1/2" high flat facing board to the fence, the full length of the fence.

Mount featherboards to facing board and table as shown, so that leading edges of featherboards will support workpiece until cut is complete, and the workpiece has been pushed completely past the cutter (sawblade, dado-head, etc.) with a push stick, as in ripping.

Before starting the operation (make sure the switch is in the off position and the blade is below the table):

1. Install featherboards so they exert pressure on the workpiece; be positive they are secure.
2. Make sure and try out the set-up to verify that the featherboards are correctly positioned.

WARNING: For your own safety, replace the sawblade guard as soon as the non-thru sawing operation is complete.

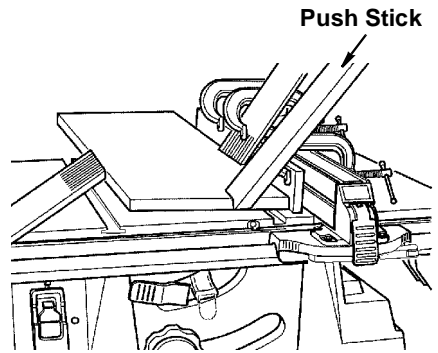
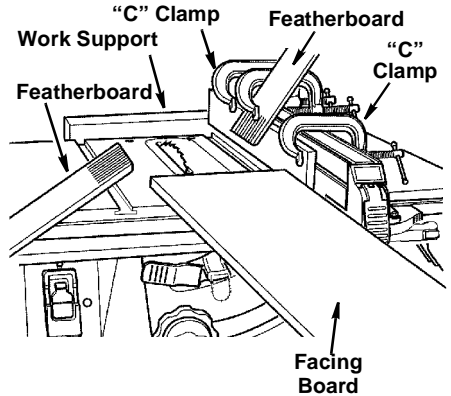

Basic Saw Operations (continued)

Resawing

Resawing is a rip cut made in a piece of wood through its thickness. The piece is typically positioned on its edge. If the piece is narrower than 3-3/8" it can be resawn in one pass with the blade guard in place. Extra supports or fixtures will be required when the edge resting on the table is too narrow for the piece to be stable or when the fence interferes with the blade guard. (See method described below)

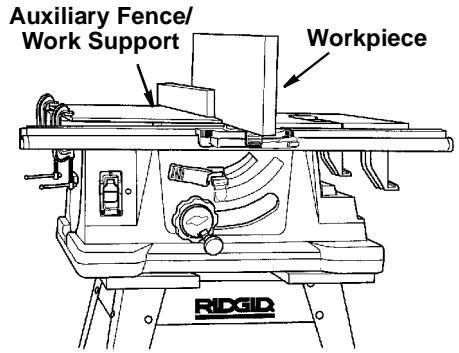

WARNING: Do not attempt to resaw bowed or warped material. It can't be properly supported. It could kickback or bind.

NOTE: To resaw a piece of wood wider than 3-3/8", or a piece needing extra support, it will be necessary to remove the blade guard and use the auxiliary fence/work support. (See "Workfeed Devices".)

Construct an auxiliary fence/work support as shown. Depending on the thickness of the workpiece the width of the auxiliary fence/work support will have to be made so that it can be attached to the table saw top with "C" clamps. Clamp the auxiliary fence/work support to the table so that the workpiece will slide easily without binding between the two fences and it will not tilt or move sideways.

WARNING: For your own safety

1. Do not "Backup" (reverse feeding) while resawing because this could cause a kickback.
2. Make first pass to a depth slightly more than one half the width of the board.
3. Keeping the same face of board against the fence rotate it end over end and make the second pass.

WARNING: For your own safety, install blade guard immediately upon completion of the resawing operation.

Using Carbide Tipped Blades

WARNING: To reduce the risk of cutting tool failure and thrown shrapnel (broken pieces of blade) read and understand all the warnings and instructions which come with carbide tipped blades. Failure to heed all carbide tipped blade warnings and safety instructions can result in serious injury.

Carbide is a very hard but brittle material. Take care when mounting, using and storing carbide blades to prevent accidental damage. Slight shocks, such as striking a tip during handling, can seriously damage

the blade. Foreign objects in the workpiece, such as wire or nails, can also cause tips to crack or break off.

Before using a carbide tipped blade, always examine the blade and tips for damage. Look for bent teeth, a bent blade, cracks, broken, missing or loose carbide tips. Do not use a carbide tipped blade if damage is found or suspected.

Do not use a carbide tipped blade without all appropriate guards in place.

Mount blade securely in proper rotation direction.

Never rotate a carbide tipped blade faster than its maximum recommended speed.

Dadoing

Dadoing is cutting a groove into the workpiece. There are a wide variety of dado heads available - be sure and consult the specific instructions included with your dado head.

WARNING: For your own safety; always read, understand and follow all directions in the instructional booklet furnished with the dado head.

The slot provided for the saw blade in the regular table insert is too small for the dado head to pass through. Therefore, a special dado insert must be purchased.

WARNING: For your own safety, always use dado insert listed under recommended accessories.

A dado is never used for thru sawing or cutting completely through a workpiece. It is used for non-thru sawing, cutting part way into the workpiece. Therefore, the blade guard and spreader cannot be used and must be removed. Use caution. Use miter gauge, rip fence, featherboards, push sticks, or fence facing board as required.

WARNING: For your own safety, always replace the blade, table insert, guard and spreader when you are finished dadoing.

The dado head is assembled to the saw arbor in the same manner as the saw blade. The arbor on the saw, is long enough so that the widest cut that can be made is 13/16" wide. It is not necessary to install the outside loose collar before screwing on the arbor nut. Make sure the arbor nut is tight.

When cutting a "deep" dado or a wide groove it is necessary to remove only a small amount of material (1/8"-1/4") at a time. Continue to increase dado elevation until the desired depth is reached.

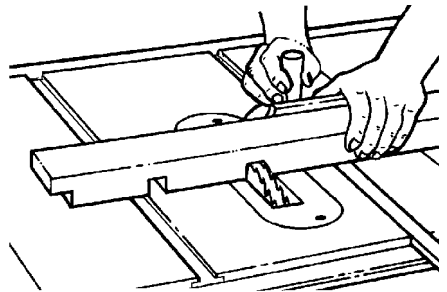
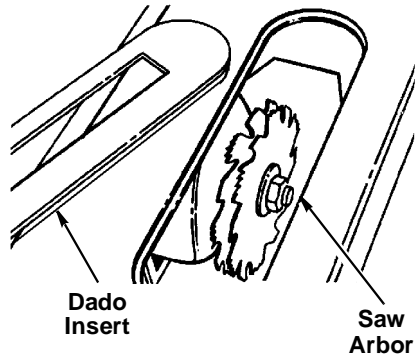

Basic Saw Operations (continued)

Rabbeting

Rabbeting is known as cutting out a section of the corner of a piece of material, across an end or along an edge.

To make a rabbet requires cuts which do not go all the way through the material. Therefore, the blade guard must be removed.

1. Remove blade guard.
2. For rabbeting along an edge (long way of workpiece) as shown add facing to rip fence approximately as high as the workpiece is wide. Adjust rip fence and blade to required dimensions; then make first cut with board flat on table as any rip (type) cut; make second cut with workpiece on edge. Follow all precautions, safety instructions, and operational instructions as for ripping, or rip type operations, including featherboards and push stick, etc.
3. For rabbeting across an end, for workpiece 10-1/2" and narrower, make the rabbet cut with the board flat on the table. Using the miter gauge fitted with a facing, follow the same procedures and instructions for cross cutting making successive cuts across the width of the workpiece to obtain the desired width of cut. Do not use the rip fence for rabbeting across the end.

WARNING: For your own safety, install blade guard immediately upon completion of rabbeting operation.

Some rabbet cuts can also be made in one pass of the workpiece over the cutter using a dado head.

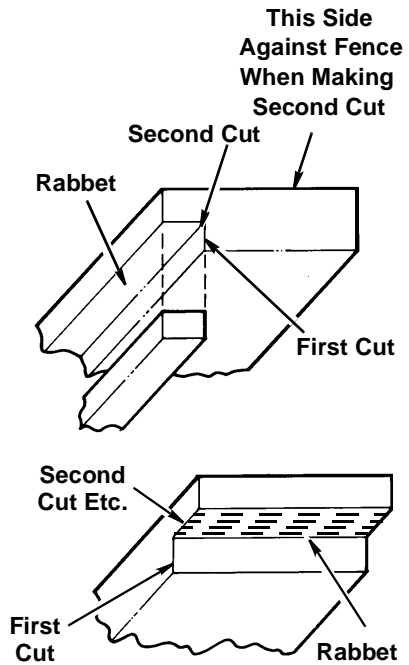

Ploughing and Molding

Ploughing is grooving with the grain the long way of the workpiece, using the fence. Use featherboards and push sticks as required.

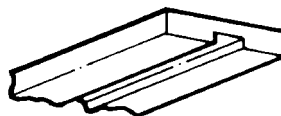

Ploughing

Molding

Molding is cutting a shape on the edge or face of the workpiece. With a molding head and a selection of different knife shapes it is possible for almost any kind of molding (base, cove, bead, etc.) to be produced.

There are a wide variety of molding heads available as well as many different shapes of knives. Be sure and consult the specific instructions included with your molding head.

WARNING: For your own safety; always read, understand, and follow all directions in the instructional booklet furnished with the molding head.

The slot provided for the sawblade in the regular table insert is too small for the molding head to pass through. Therefore, a special dado/molding insert must be purchased.

WARNING: For your own safety, always use molding insert listed under recommended accessories.

When using the molding head it will be necessary to remove the blade guard and spreader. Use caution. Use miter gauge, fence, featherboards, push sticks or fence facing board, etc., as required.

WARNING: For your own safety, always replace the blade, table insert, guard and spreader when you are finished molding.

A typical molding head is shown. The various shapes of knives are fitted into grooves in the cutterhead and secured with a screw(s).

The molding head is assembled to the saw arbor in the same manner as the saw blade. It is not necessary to install the outside loose collar before screwing on the arbor nut. Make sure the arbor nut is tight.

It is necessary to use an auxiliary fence when shaping edges of a workpiece. Position the auxiliary fence over the cutterhead with the cutter head below the surface of the saw table. Turn the saw "ON" and slowly raise the cutterhead. The cutterhead will then cut its own groove in the auxiliary fence.

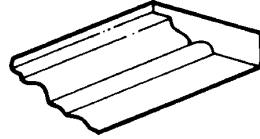

Molding

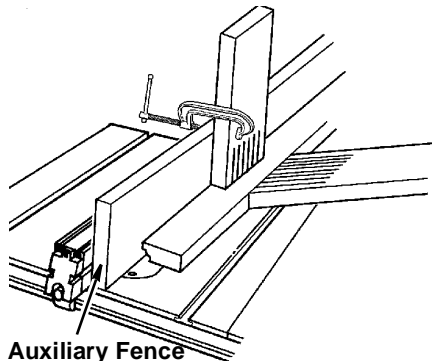
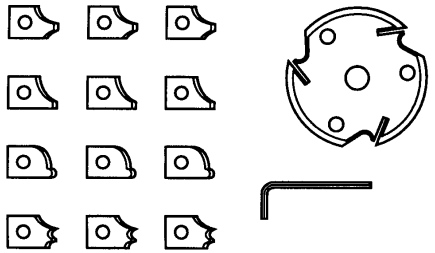
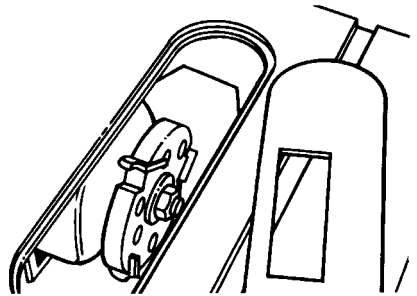

Auxiliary Fence

Maintaining Your Table Saw

Maintenance

WARNING: For your own safety, turn switch "OFF" and remove plug from power source outlet before maintaining or lubricating your saw.

- Do not allow sawdust to accumulate inside the saw. Frequently blow out any dust that may accumulate inside the saw cabinet and the motor.
- Clean your cutting tools with a gum and pitch remover.
- The cord and the tool should be wiped with a dry clean cloth to prevent deterioration from oil and grease.
- A coat of furniture paste wax applied to the table will help to keep the surface clean and allow workpieces to slide more freely.
- If the power cord is worn, cut, or damaged in any way, have it replaced immediately.

Anti-Kickback Pawls

Make sure the teeth of the anti-kickback

pawls are always sharp. To sharpen:

1. Remove blade guard.
2. Rotate pawl toward rear of spreader so that teeth are above top of spreader.

Anti-Kickback

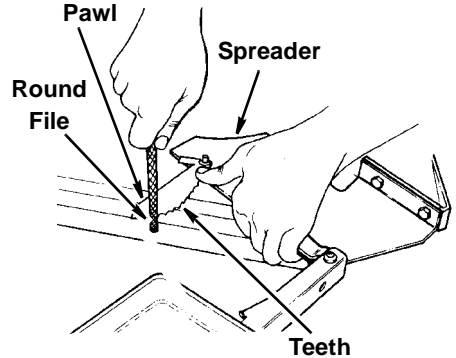

3. Hold spreader with left hand and place pawl over corner of workbench as shown.
4. Using a small round file (smooth cut) sharpen the teeth.
5. Reinstall blade guard.

Adjusting Nylon Set Screw

If the sawblade has a very slight amount of lateral movement (left-right movement), or if the sawblade is elevated and tends to lower itself slightly, the nylon set screw needs to be tightened.

1. Bevel the sawblade to 45°.
2. Locate the 10-32 x 3/4 nylon set screw and nut. Reference service key #27 & 28 page 48. See illustration.
3. Turn the nut counterclockwise to loosen.
4. Tighten the set screw.
5. Retighten the nut.
6. Bevel the sawblade back to 90°.

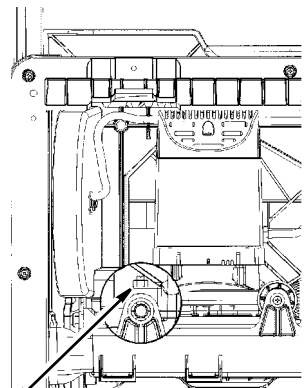

Nylon Screw and Nut

Bottom View of Saw

WARNING: To reduce the risk of injury from unexpected starting or electrical shock, unplug the power cord before working on the saw.

WARNING: To reduce the risk of electrical shock, fire or injury, use only parts identical to those identified in the parts list reassemble exactly as original assembly to reduce the risk of electrical hazards.

Replacing Carbon Brushes

The carbon brushes furnished will last approximately 50 hours of running time or 10,000 on/off cycles. To inspect or replace, first unplug the saw. Lower blade all the way, bevel to 45° and lock. Turn saw upside down. Remove brush cap with a screwdriver. Brush assembly is spring loaded and will pop out when you remove the brush cap. Remove brush assembly and check for wear. Replace both brushes when either has less than 1/4" length of carbon remaining. **Do not** replace one side without replacing the other. Reassemble using new brush assemblies. Make sure curvature of brush matches curvature of motor and that brush moves freely in brush tube. Make

sure brush cap is oriented correctly (straight) and replace. Tighten brush cap securely. Do not overtighten.

Lubrication

The saw motor bearings and gear case have been packed at the factory with proper lubricant and require no additional lubrication. The following parts should be oiled occasionally with SAE no. 20 or no. 30 engine oil.

1. Elevation screw threads. (First clean with a solvent recommended for gum and pitch removal).
2. Bearing points in blade guard and miter gauge.

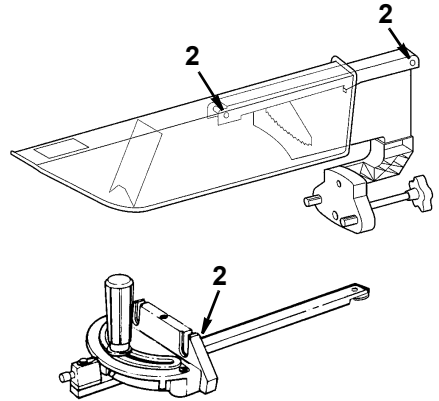

RIDGID Recommends the Following Accessories

Item	SKU No.
Table Saw Miter Gauge	
Hold Down Clamp	AC1022
Dado/Molding Insert	AC1040
Zero Clearance Insert	AC1045
Universal Power Tool Legset	AC9910

Do not use any accessory unless you have received and read complete instructions for its use.

NOTE: AC1025, AC1030 and AC1035 Blade Inserts are not compatible with this saw.

WARNING: Use only accessories recommended for this saw. Using other accessories may be dangerous.

Troubleshooting

WARNING: For your own protection, turn switch “OFF” and always remove plug from power source outlet before troubleshooting.

General

Trouble	Probable Cause	Remedy
Excessive Vibration	1. Blade out of balance or damaged	1. Replace blade.
Cannot make square cut when crosscutting.	1. Miter gauge not adjusted properly.	1. See “Adjustments” section “Miter Gauge.”
Cut binds, burns or stalls motor when ripping.	1. Dull blade or improper tooth set. 2. Blade is heeling. 3. Warped board 4. Rip fence not parallel to blade. 5. Spreader out of alignment.	1. Sharpen or replace blade. 2. See “Alignment” section, “Heeling Adjustment”. 3. Make sure concave or hollow side is facing “down” feed slowly. 4. See “Alignment” section, “Aligning Rip Fence.” 5. See “Alignment” section, “Installing Blade Guard.”
Cut not true at 90° or 45° bevel positions.	1. Indexes not properly adjusted.	1. See “Alignment” section, “Blade Tilt, or Squareness of Blade to Table”.
Elevating hand-wheel turns hard.	1. Sawdust on threads of elevating screw.	1. See “Maintenance” and “Lubrication” sections.

Motor

NOTE: Motors used on wood working tools are particularly susceptible to the accumulation of sawdust and wood chips and should be blown out or “Vacuumed” frequently to prevent interference with normal motor ventilation.

Trouble	Probable Cause	Remedy
Excessive Noise	1. Motor	1. Have motor checked by qualified service technician. Repair service is available at your nearest Authorized Service Center.
Motor fails to develop full power. NOTE: Low Voltage: (Power output of motor decreases rapidly with decrease in voltage at motor terminals.	1. Circuit overloaded with lights, appliances and other motors. 2. Wiring circuit (extension cord) too long or undersize. 3. General overloading of power company facilities. (In some sections of the country, demand for electrical power may exceed the capacity of existing generating and distribution systems.) 4. Incorrect fuses or circuit breakers in power line.	1. Do not use other appliances or motors on same circuit when using the saw. 2. Increase wire sizes, or reduce length of circuit. See “Motor Specifications and electrical Requirements” section. 3. Request a voltage check from the power company. 4. Install correct fuses or circuit breakers.
Motor starts slowly or fails to come up to full speed	1. Low voltage. 2. Windings burned out or open.	1. Request voltage check from the power company. 2. Have motor repaired or replaced.
Motor overheats	1. Motor overloaded 2. Improper cooling. (Air circulation restricted through motor due to sawdust, accumulating inside of saw.)	1. Feed work slower into blade. 2. Clean out sawdust to provide normal air circulation through motor. See “Maintenance” and “Lubrication” section.
Motor stalls (resulting in blown fuses or tripped circuit breakers)	1. Voltage too low to permit motor to reach operating speed. 2. Fuses or circuit breakers do not have sufficient capacity.	1. Request voltage check from the power company. 2. Install proper size fuses or circuit breakers.
Frequent opening of fuses or circuit breakers	1. Motor overloaded 2. Fuses or circuit breakers do not have sufficient capacity.	1. Feed work slower into blade. 2. Install proper size fuses or circuit breakers.
Motor runs intermittently, sparks excessively or fails to start	1. Worn or damaged brushes	1. Replace brushes. See “Maintenance” section.

**Parts List for RIDGID 10 Inch Table Saw
Model No. TS24001**

RIDGID parts are available on-line at www.ridgidparts.com

Figure 1

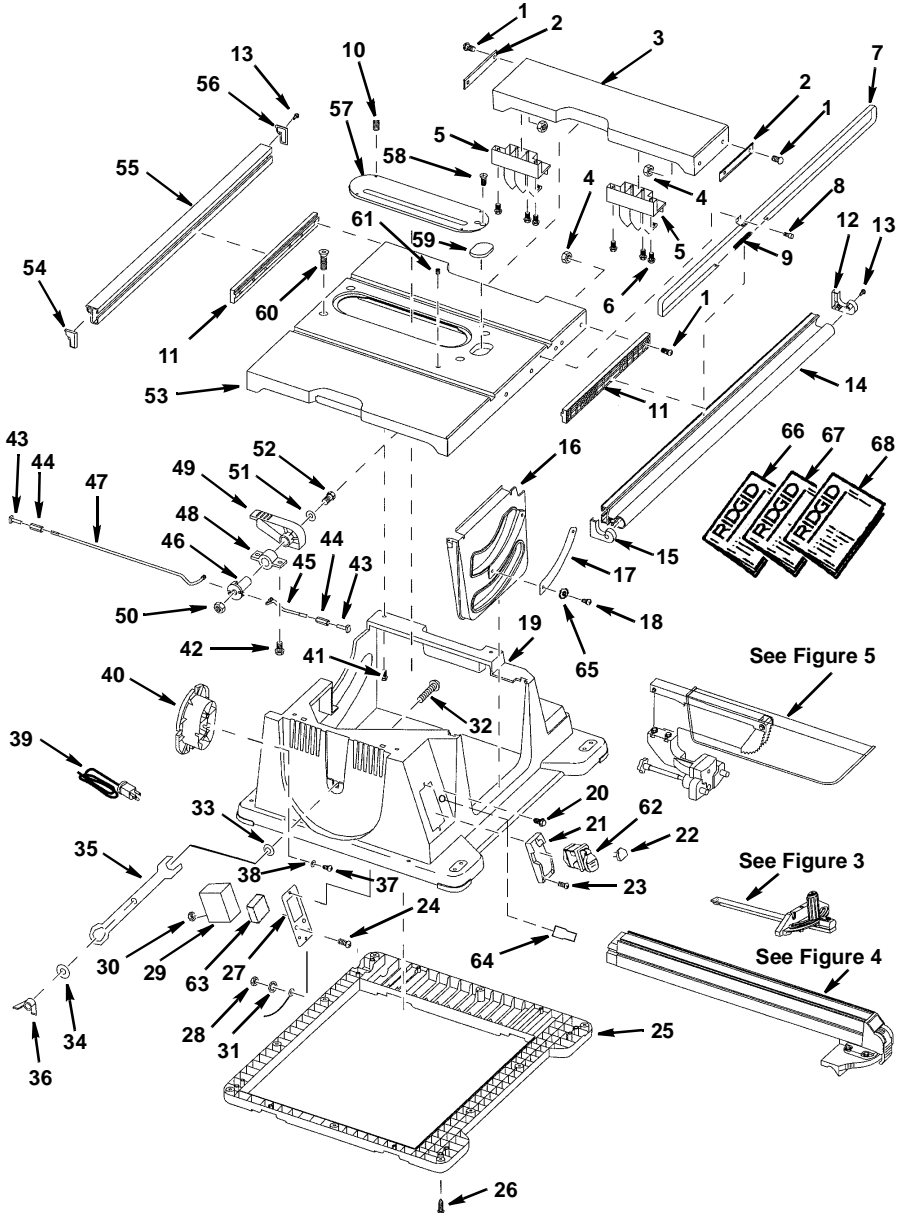

Repair Parts

Parts List for RIDGID 10 Inch Table Saw Model No. TS24001

RIDGID parts are available on-line at www.ridgidparts.com

Figure 1

Always Order by Part Number - not by Key Number

Key No.	Part No.	Description	Key No.	Part No.	Description
1	126317	* Bolt Carriage 1/4-20 x 1	36	827874	Nut Wing Nylon 1/2-13
2	827518	Mount Rail Extension	37	808380-17	* Screw Pan Hd #10 x 3/4 Plastite
3	827545	Table Extension	38	805550-5	Washer 7/32 x 5/8 x 1/16
4	73352	* Nut Hex Flange 1/4-20	39	830405	Cord w/Plug
5	827478	Clip Fence	40	830406	Wrap Cord
6	159572-146	* Screw Hex Wash Hd Ty T 10-32 x 7/8	41	274622	Screw Hex Hd Ty T 1/4-20 x 1
7	830397	Scale Rip	42	821521	Screw Hex Hd Shoulder .312
8	809813-1	Screw Pan Rec 6-32 x 1/2	43	827463	Bolt T 1/4-20
9	827872	Spring Rip Scale	44	827482	Coupling 1/4-20
10	104879	Screw Lock Set 10-32x3/16	45	827515	Link Locking Front
11	827533	Slider Rail	46	827523	Pivot Linkage
12	830345	Cap Rail Front Right	47	827515-1	Link Locking Rear
13	448013	* Screw Pan Hd Ty Ab N8x1/2	48	830377	Bearing Rail Lock
14	830378	Rail Front	49	827514	Lever Table Lock
15	830396	Cap Rail Front Left	50	274205	Nut Lock 1/4-20
16	827497	Panel Front	51	805552	* Washer 17/64 x5/8 x 1/16
17	827870	Scale Bevel	52	813051-5	* Screw Pan Hd 1/4-20 x 2-3/4
18	808380-2	* Screw Pan Hd #8 x 3/8	53	830376	Table Main
19	829971-8	Base w/Labels	54	827645	Cap Rear Rail Left
20	9420474	* Screw Hex Wash Hd Ty T 10-32 x 1/2	55	827525	Rail Rear
21	826395	Bezel Switch	56	827470	Cap Rear Rail Right
22	AC1000	† Key Switch	57	509492	Insert Asm
23	808380-18	Screw Pan Hd #6 x 3/4 Plastite	58	809374	Screw Flat Hd 10-32 x 1
24	808275-4	* Screw Pan Hd 8-32 x 3/8	59	826390	Insert Ind-I-Cut
25	827493	Foot Base	60	805297-12	Screw Soc Flat Hd 5/16-18 x 1
26	808380-5	* Screw Pan Hd #8 Plastite	61	138671	Screw Set 5/16-18 x 5/8
27	830399	Plate Switch Box	62	826347	Switch Locking
28	805475	* Nut Hex 8-32	63	829971-7	Circuit Asm
29	830398	Box Switch	64	829971-6	Switch Reset Asm
30	169123-2	Relief Strain	65	805549-22	Washer #10 13/64 x 3/8 x .031
31	138164	* Lockwasher #8	66	SP6499	Owners Manual - English
32	827925	Bolt Carriage 1/2-13 x 1-1/2	67	SP6499S	Owners Manual - Spanish
33	827873	Nut Push 1/2	68	SP6499F	Owners Manual - French
34	827921	Washer Flat Nylon			
35	827548	Wrench Arbor			

* Standard Hardware Item - May be purchased locally

† These parts are available where you purchased your saw.

**Parts list for RIDGID 10 Inch Table Saw
Model No. TS24001**

RIDGID parts are available on-line at www.ridgidparts.com

Figure 2

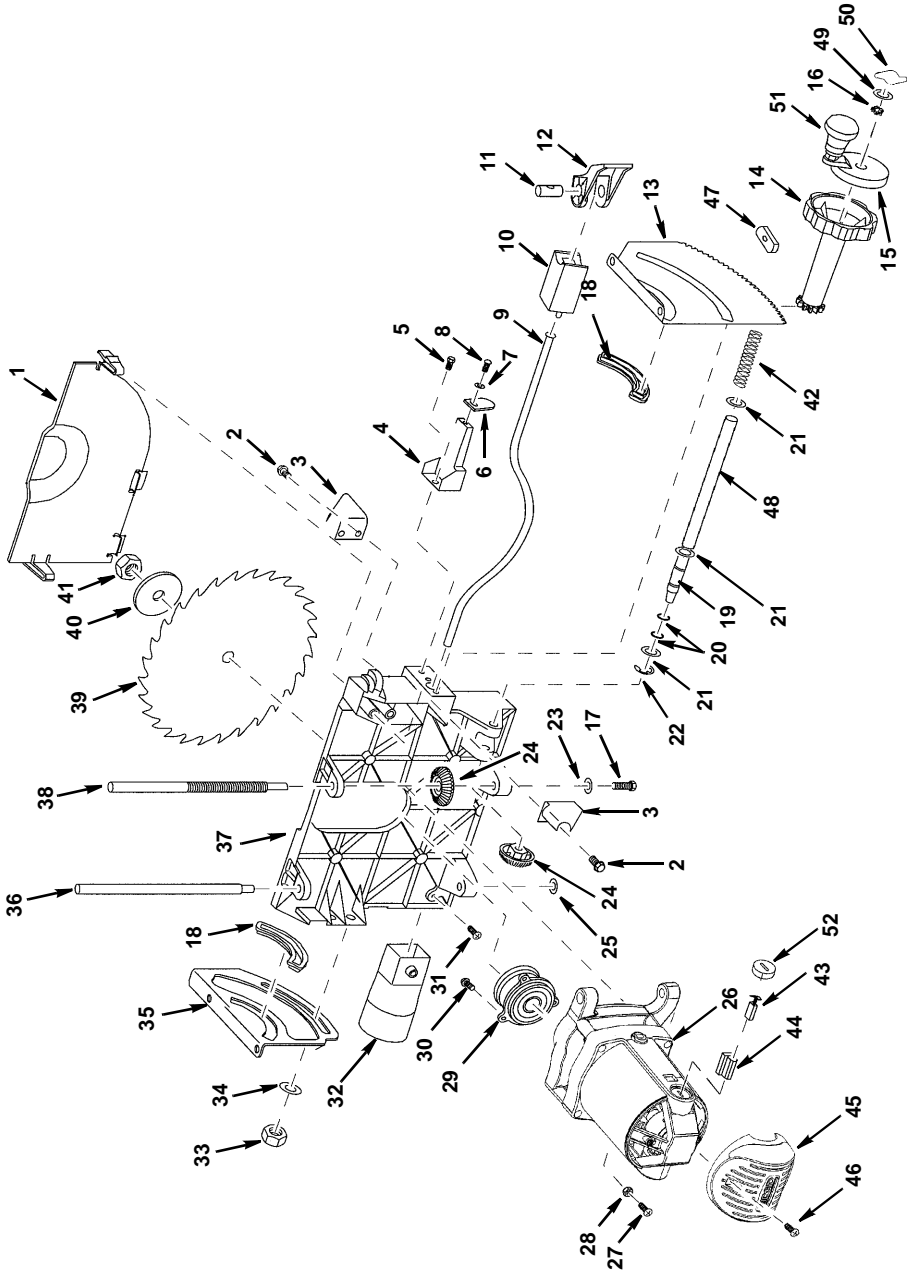

Repair Parts

Parts List for RIDGID 10 Inch Table Saw Model TS24001

RIDGID parts are available on-line at www.ridgidparts.com

Figure 2

Always Order by Part Number - not by Key Number

Key No.	Part No.	Description	Key No.	Part No.	Description
1	827483	Cover Blade	27	827863	Screw Set Nylon
2	370625	* Screw Hex Wash Hd 1/4-20 x 1/2	28	827864	Nut Hex Nylon 10-32
3	827619	Plate Bevel Stop	29	830412	Arbor Asm
4	827540	Support Bevel Indicator	30	9420474	* Screw Hex Ty T 10/32 x 1/2
5	141594-46	* Screw Soc Cap 1/4-20 x 5/8	31	808380-17	* Screw Pan Hd #10 x 3/4
6	824334-1	Indicator	32	827476	Chute Sawdust
7	805550-5	* Washer 7/32 x 5/8 x 1/16	33	60249	* Nut Lock 3/8-16
8	808380-17	* Screw Pan Hd #10 x 3/4	34	60014	* Washer .380 x 47/64 x 3/32
9	827459	Bar Locking	35	827520	Mount Rear
10	827862	Clamp Asm Bevel	36	827531	Shaft Guide
11	827522	Pivot Bevel Lock	37	830380	Cradle
12	827500	Handle Bevel Lock	38	827529	Shaft Elevation
13	827519	Mount Front	39	830394	Blade 10" 24T Carb.
14	830390	Knob Asm Bevel	40	827465	Collar Blade
15	830391	Handle Asm Elevation	41	6362	Nut Arbor
16	37937	* Washer 17/64 x 5/8 x 1/32	42	830386	Spring
17	809372-7	* Screw Pan Hd 10-32 x 5/8	43	816768	Brush
18	827467	Bushing Trunnion	44	826017	Holder Brush
19	829971-9	Shaft Elevation Crank (Includes "O" Rings)	45	828064	Cover Motor Rear
20	821421-11	Ring "O" 3/8 x 1/16	46	828122-1	Screw Wash Hd Cr M4-10
21	805561-4	Washer .505 x 3/16 x 1/32	47	809398	Nut Weld
22	805641-4	Ring Retaining 5133-50	48	830385	Spacer Elev Lock
23	60136	* Washer 13/64 x 5/8 x 1/32	49	60415	Washer Spring
24	827496	Gear Elevation	50	830393	Knob Elevation Lock
25	802612-8	Nut Push 3/8	51	830392	Knob Swivel
26	830381	Motor Asm	52	830250	Cover, Brush

* Standard Hardware Item - May be purchased locally

**Parts List for RIDGID 10 Inch Table Saw
Model No. TS24001**

RIDGID parts are available on-line at www.ridgidparts.com

Figure 3 - Miter Gauge Assembly

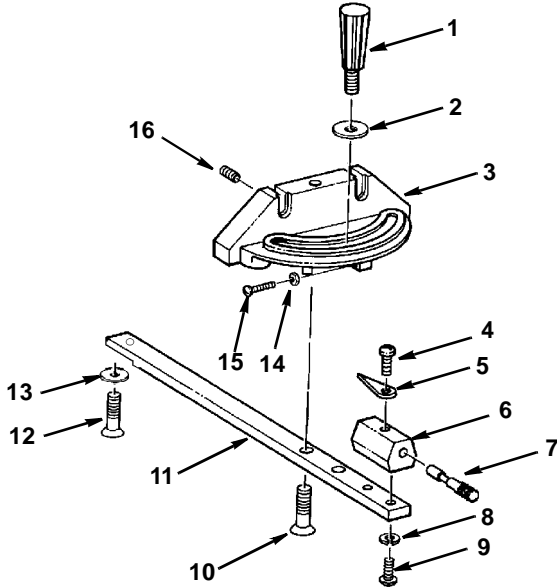

Always Order by Part Number - Not by Key Number

Key No.	Part No.	Description
-	830338	Miter Gauge Asm. Complete
1	826506-1	Knob
2	821063-5	* Washer 8 x 23 x 1.8
3	826663	Gauge, Miter
4	824723-1	* Screw, Pan Hd. 8/32 x 5/16
5	123069-1	Indicator
6	830351	Block, Miter Gauge Indicator
7	830352	Pin, Miter
8	140755-15	* Lockwasher #8
9	824723	* Screw, Pan Hd 8-32 x 5/8
10	818470-4	Screw Flat Hd. M6 x 1.0-16
11	830350	Rod, Miter Gauge
12	830354	Screw, Flat Head
13	830353	Washer, "T" Slot
14	134530	* Nut Hex 6-32
15	809813-4	Screw Pan Hd. 6-32 x 5/8
16	818471-6	Screw, Set 5 x 0.8-5

* Standard Hardware Item - May be purchased locally

Parts List for RIDGID 10 Inch Table Saw Model No. TS24001

RIDGID parts are available on-line at www.ridgidparts.com

Figure 4 - Fence Assembly

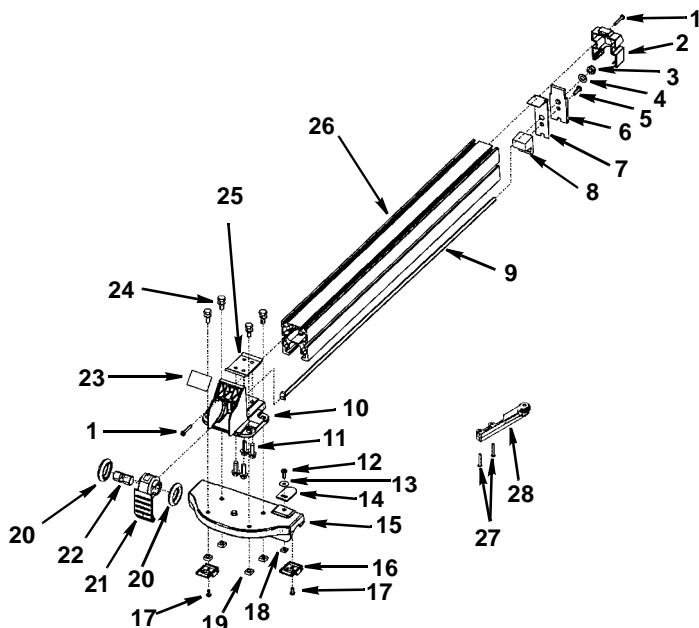

Always Order by Part Number - not by Key Number

Key No.	Part No.	Description	Key No.	Part No.	Description
-	830421	Fence Complete	17	809169-3	* Screw Pan Hd. Ty "T" 8-32 x 3/8
1	809492-5	Screw Pan Hd. Ty "T" 8-32x1	18	822138-1	* Nut Sq 10-32
2	824350-1	Cap Channel Rear	19	62636	* Nut Sq 1/4-20
3	820129	* Nut Lock 5/16-18	20	824326	Bearing Ball Angular Contact
4	274865	* Washer 21/64 x 5/8 x 1/16	21	830425	Lever Cam Fence
5	9416390	* Screw Pan Hd. Ty "T" 10-32 x 5/8	22	824329	Pin Cam
6	824328-1	Plate Lock	23	827876	Label RIDGID
7	824332	Spring Lock	24	828173	* Screw Hex Washer Hd. 1/4-20 x 3/4
8	824349-1	Slide Rear Fence	25	824330-1	Plate Fence Channel
9	824342-1	Rod Fence Lock	26	829971-10	Channel Fence
10	827507	Housing Rip Fence	27	806752-2	Screw Pan Hd Ty "T" 10-32 x 1-1/4
11	9422329	* Scr Hex Hd TY "T" 1/4-20 x 3/4	28	829706	Micro Adjust Asm
12	809372-3	* Screw Pan 10-32 x 1/2	Hardware for Attaching Wood Facing		
13	60136	* Washer 13/64 x 5/8 x 1/32	159653-3	Bolt Sq. Hd. 1/4-20 x 3/4	
14	830281	Indicator	805552	* Washer 17/64 x 5/8 x 1/16	
15	830426	Head Rip Fence	115120	* Nut Hex 1/4-20	
16	827532	Slide Fence Head			

* Standard Hardware Item - May be purchased locally

Repair Parts

Parts List for RIDGID 10 Inch Table Saw Model No. TS24001

RIDGID parts are available on-line at www.ridgidparts.com

Figure 5 - Guard Assembly

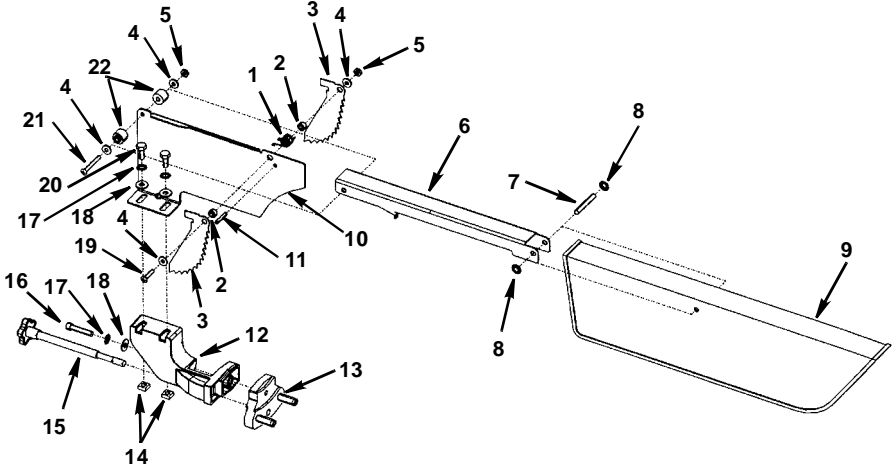

Always Order by Part Number - not by Key Number

Key No.	Part No.	Description	Key No.	Part No.	Description
-	827499	Guard Complete	11	803422-163	Pin, Roll 3/16 x 15/16
1	62519	Spring, Pawl	12	827541	Support Spreader
2	827646	Spacer, Pawl	13	827877	Mount Spreader
3	827648-1	Pawl	14	62636	Nut Square 1/4-20
4	805549	* Washer, 13/64 x 9/16 x 1/32	15	827511	Knob Guard
5	60012	Nut Lock 10-32	16	805461-7	Screw Hex Hd 1/4-20 x 1
6	827649-1	Support, Guard	17	114604	* Lockwasher Ext 1/4
7	62390	Pin Guard 1/4 x 1-3/4	18	37937	* Washer 17/64 x 5/8 x 1/32
8	802612	Nut Push 1/4	19	806214-3	Screw Soc Cap 10-32 x 7/8
9	826466	Guard w/Label	20	179793	* Screw Hex Hd 1/4-20 x 5/8
10	827536	Spreader Blade	21	806214-4	Screw Soc Cap 10-32x1-1/2
			22	827647	Spacer Support

* Standard Hardware Item - May be purchased locally

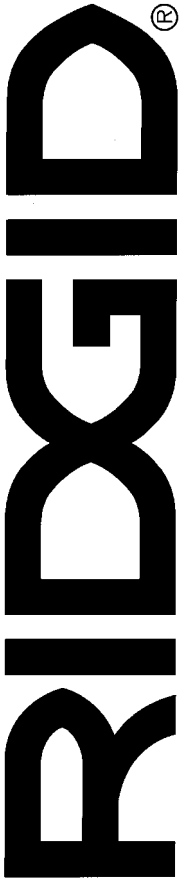

RIDGID® HAND HELD AND STATIONARY POWER TOOL LIMITED THREE YEAR WARRANTY AND 90 DAY SATISFACTION GUARANTEE POLICY

This product is manufactured under license from Ridgid, Inc. by One World Technologies, Inc.. All warranty communications should be directed to One World Technologies, Inc. at (toll free) 1-866-539-1710.

90-Day Satisfaction Guarantee Policy

During the first 90 days after the date of purchase, if you are dissatisfied with the performance of this Ridgid® tool for any reason, you may return the tool to the dealer from which it was purchased for a full refund or exchange. To receive a replacement tool you must present proof of purchase and return all original equipment packaged with the original product. The replacement tool will be covered by the limited warranty for the balance of the three year warranty period.

What is covered under the Limited Three Year Warranty

This warranty covers all defects in workmanship or materials in this RIDGID® tool for the three year period from the date of purchase. This warranty is specific to this tool. Warranties for other RIDGID® products may vary.

How to obtain service

To obtain service for this RIDGID® tool you must return it, freight prepaid, to an authorized RIDGID® service center for hand held and stationary power tools. You may obtain the location of the authorized service center nearest you by calling (toll free) 1-866-539-1710 or by logging on to the RIDGID® website at www.ridgidwoodworking.com. When requesting warranty service, you must present the proof of purchase documentation, which includes a date of purchase. The authorized service center will repair any faulty workmanship, and either repair or replace any defective part, at our option at no charge to you.

What is not covered

This warranty applies only to the original purchaser at retail and may not be transferred. This warranty only covers defects arising under normal usage and does not cover any malfunction, failure or defect resulting from misuse, abuse, neglect, alteration, modification or repair by other than authorized RIDGID® service center for hand held and stationary power tools. One World Technologies, Inc. makes no warranties, representations or promises as to the quality or performance of its power tools other than those specifically stated in this warranty.

Additional Limitations

To the extent permitted by applicable law, all implied warranties, including warranties of MERCHANTABILITY or FITNESS FOR A PARTICULAR PURPOSE, are disclaimed. Any implied warranties, including warranties of merchantability or fitness for a particular purpose, that cannot be disclaimed under state law are limited to three years from the date of purchase. One World Technologies, Inc. is not responsible for direct, indirect, incidental or consequential damages. Some states do not allow limitations on how long an implied warranty lasts and/or do not allow the exclusion or limitation of incidental or consequential damages, so the above limitations may not apply to you. This warranty gives you specific legal rights, and you may also have other rights which vary from state to state.

Stock No. TS2400

Model No. TS24001 Serial No. _____

Model and serial numbers may be found on the left rear side of the base. You should record both model and serial number in a safe place for future use.

**QUESTIONS OR COMMENTS?
CALL 1-866-539-1710**

www.ridgidwoodworking.com

**Please have your Model Number and Serial
Number on hand when calling.**